

READ AND SAVE THIS INSTRUCTIONS FOR FUTURE USE

ASSEMBLY & INSTRUCTION MANUAL

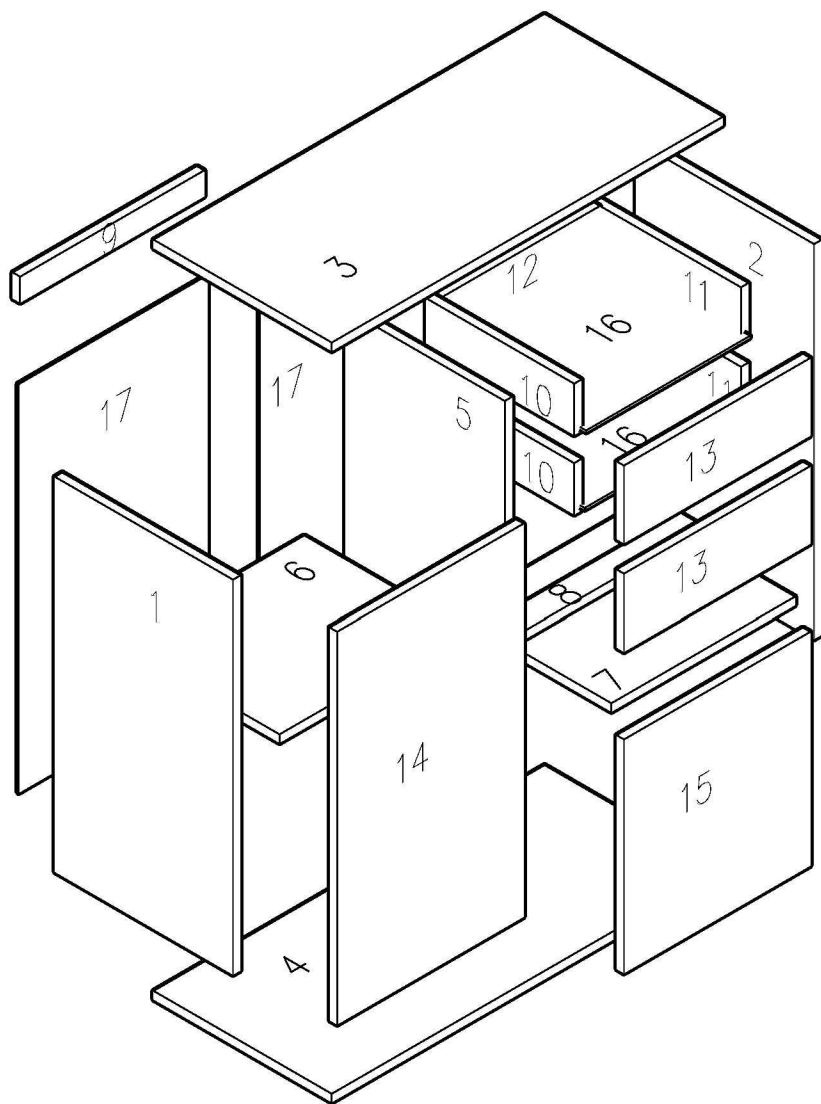

BOX 1/1:





PART NO.	PARTS	QTY
①		X1
②		X1
③		X1
④		X1
⑤		X1
⑥		X1
⑦		X1
⑧		X1
⑨		X2
⑩		X2
⑪		X2
⑫		X2
⑬		X2
⑭		X1
⑮		X1
⑯		X2
⑰		X2

PACKING DETAILS: TOTAL 1 BOX

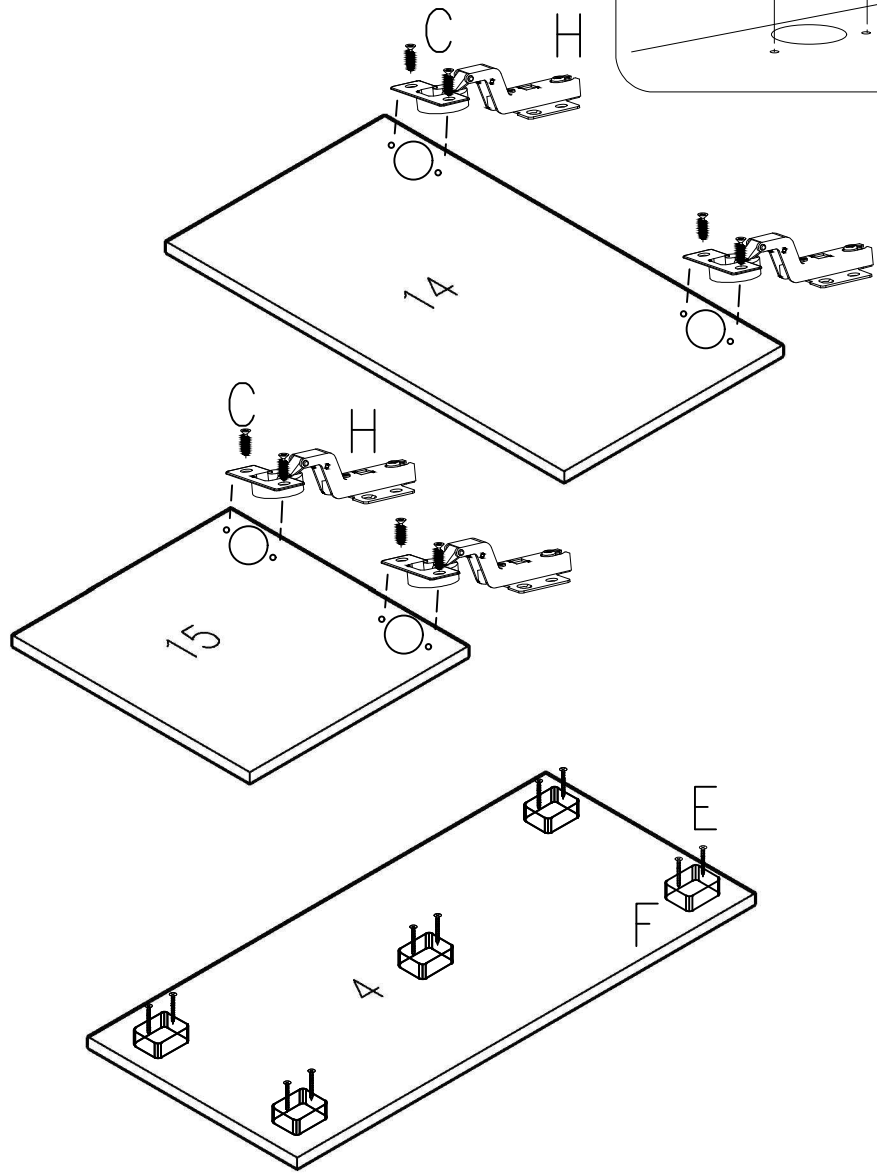
PART NO.	PARTS	QTY
Ⓐ		X37
Ⓑ		X16
Ⓒ		X58
Ⓓ		X9
Ⓔ		X10
Ⓕ		X5
Ⓖ		X2
Ⓗ		X4
Ⓘ		X4
Ⓙ		X8
Ⓚ		X4
Ⓛ		X2
Ⓜ		X37



1

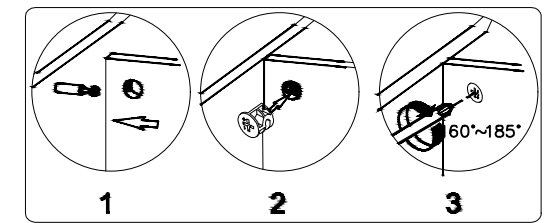
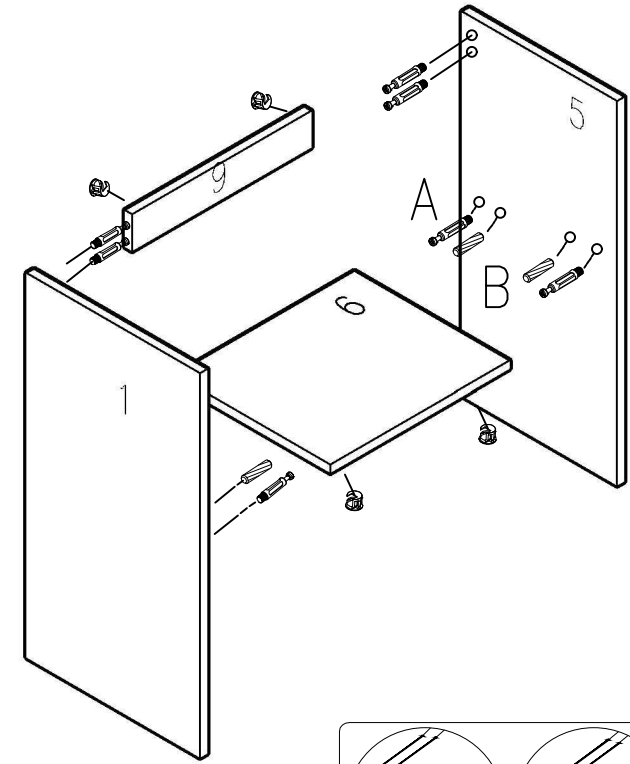

- F X5

- H X4

- C X8

- E X10

2

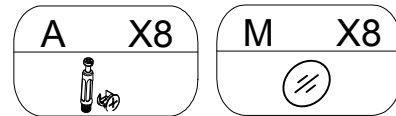
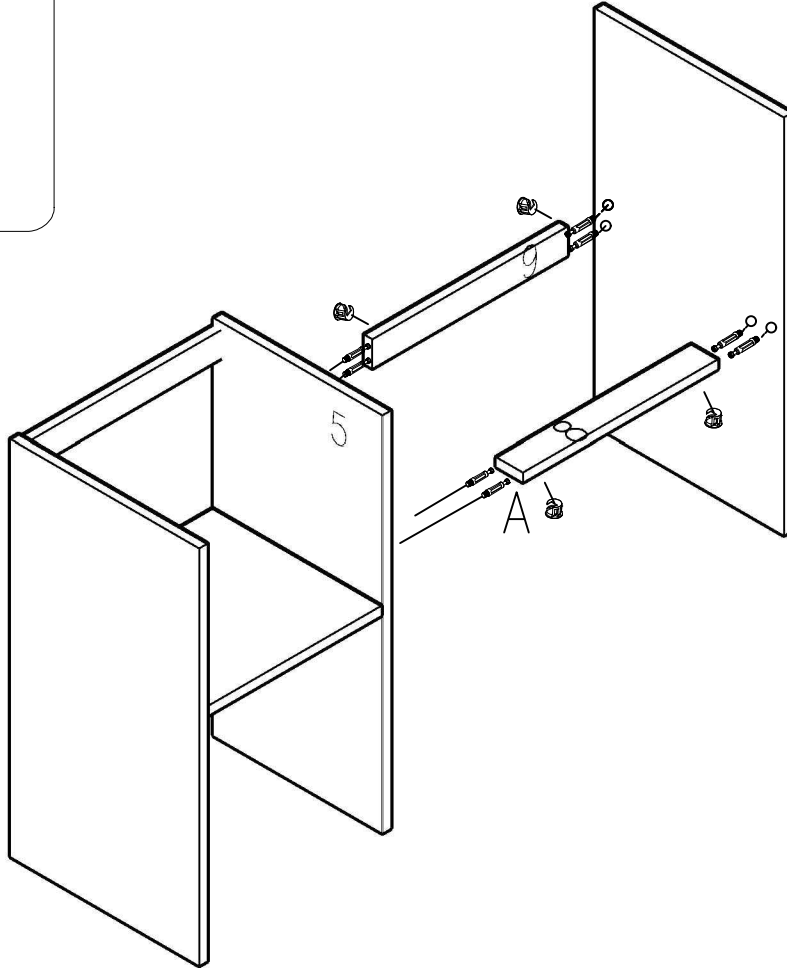
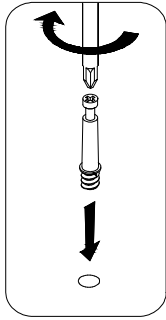
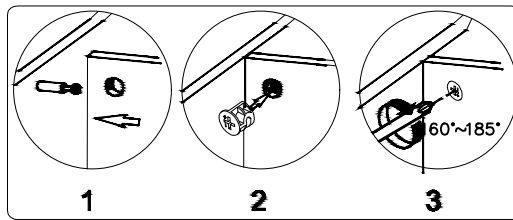

- A X8

- B X4

- M X8

3

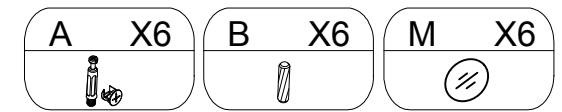
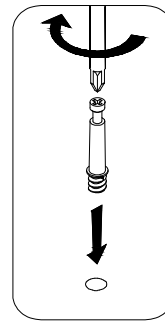
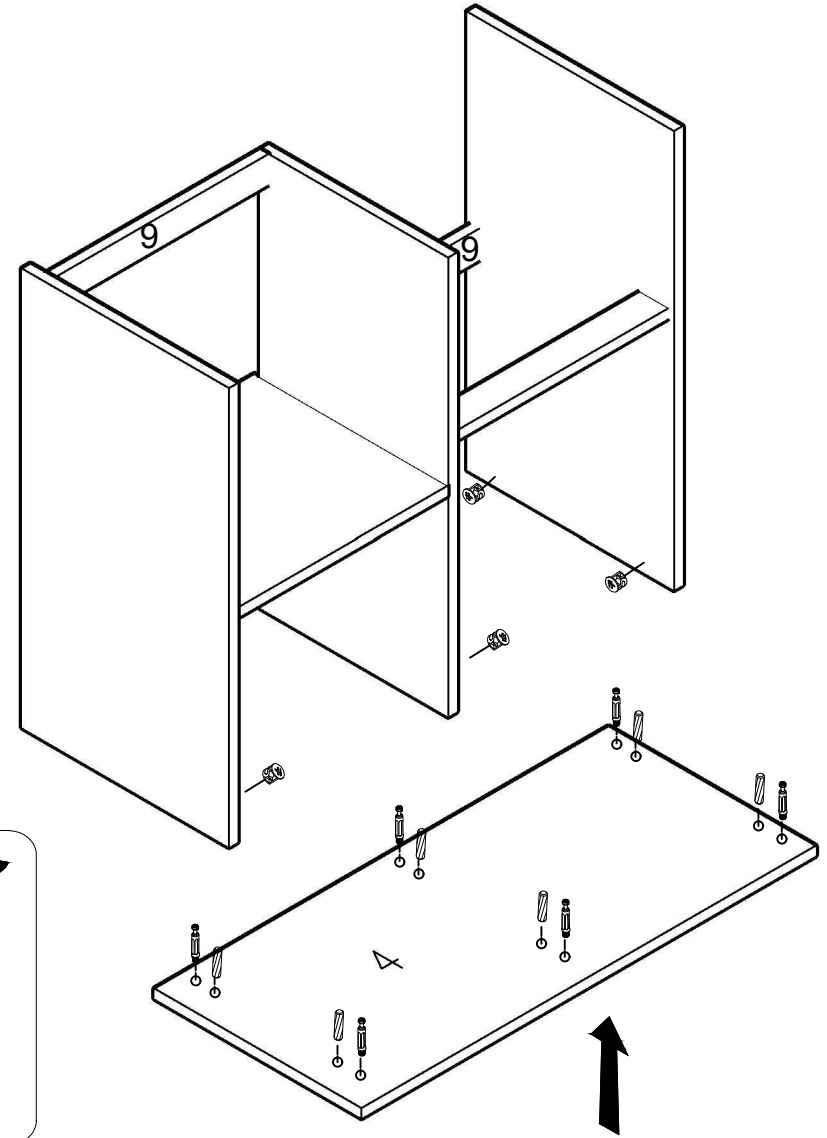

4

First, remove the protective film on the surface needs to be removed !



5

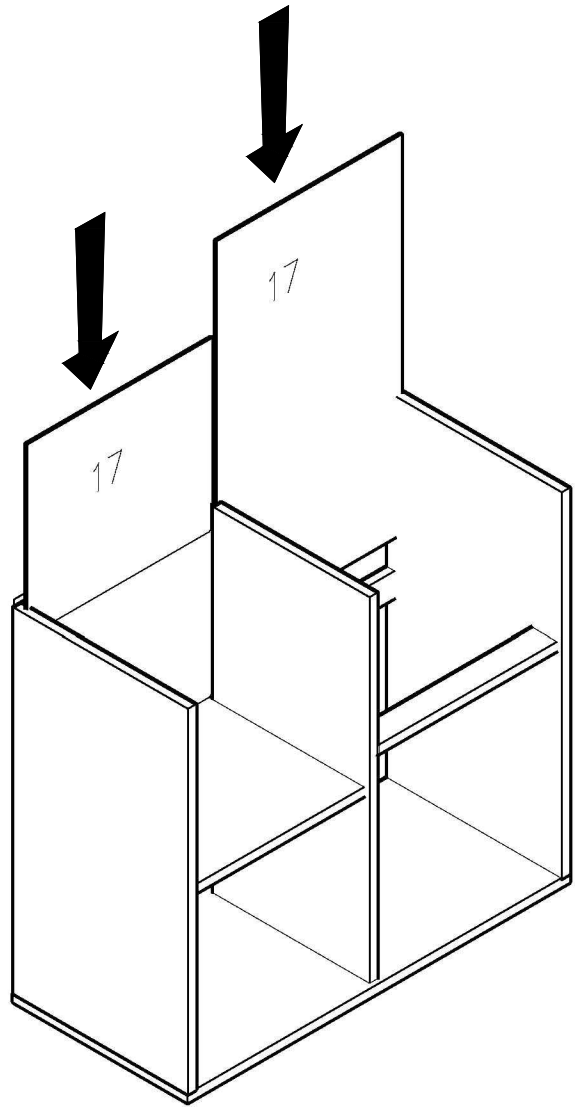

6

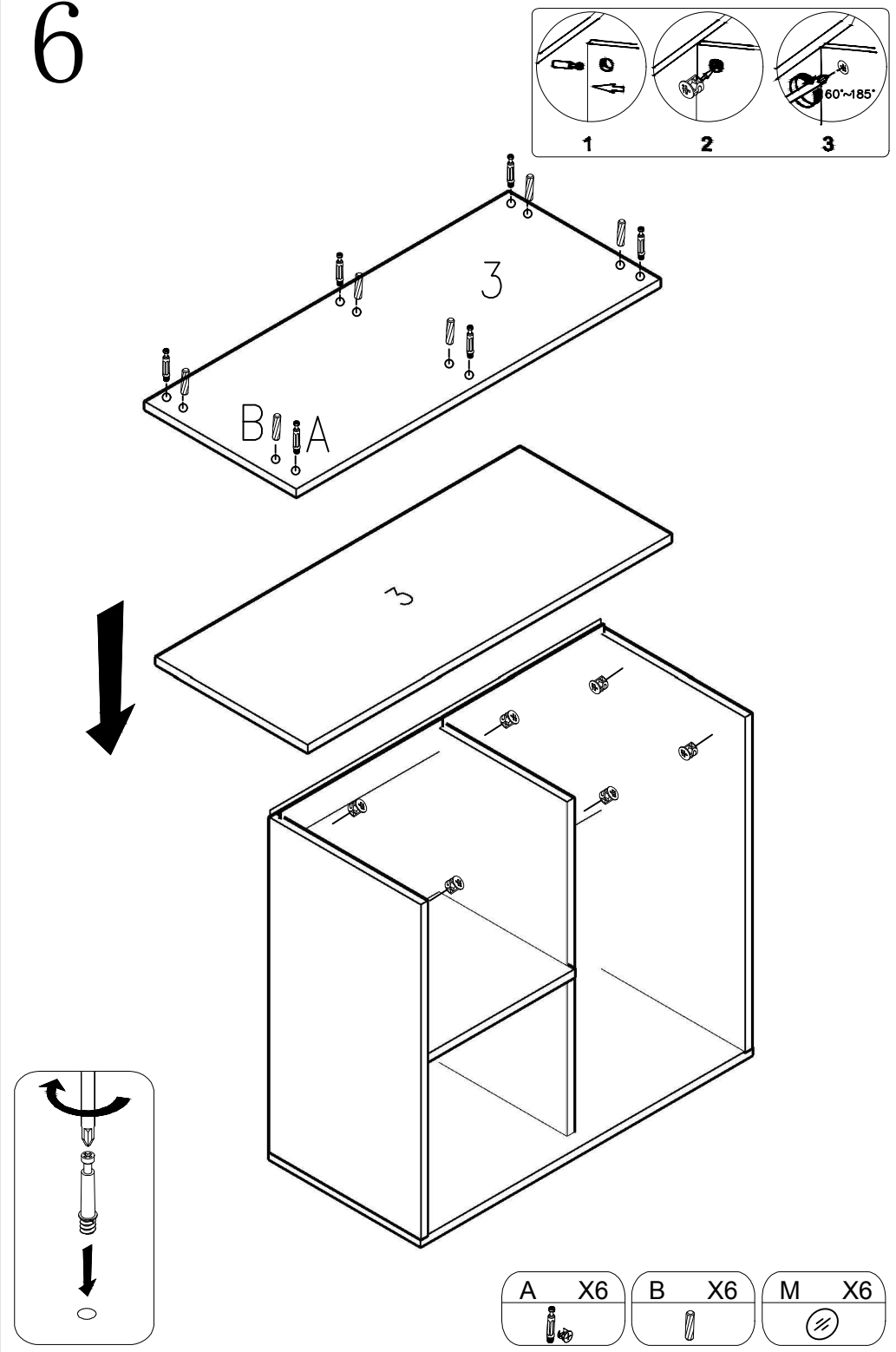

7

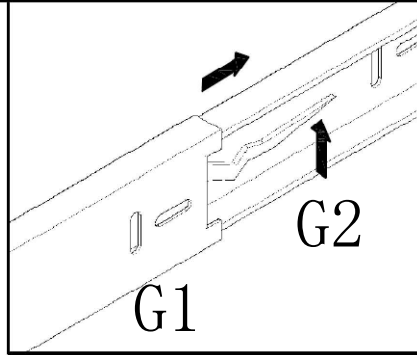
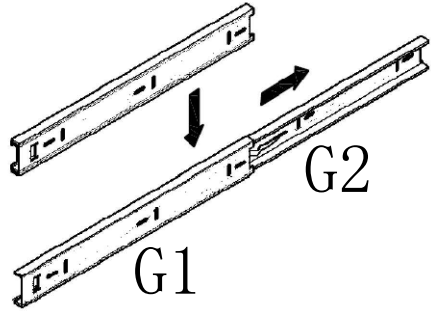

8

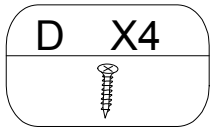
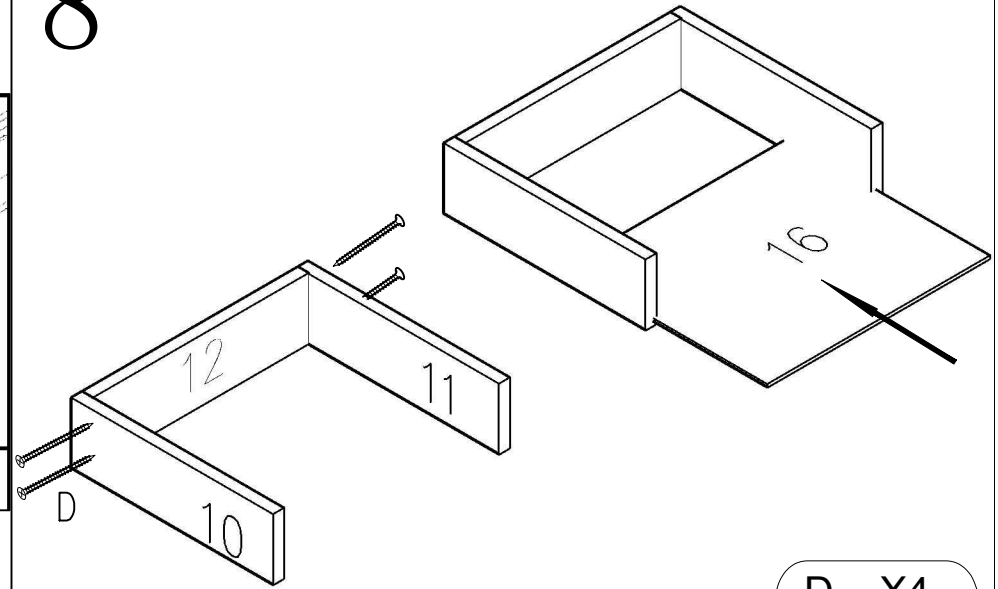

9

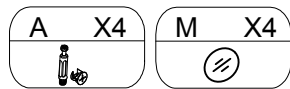
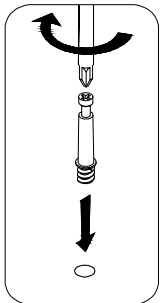
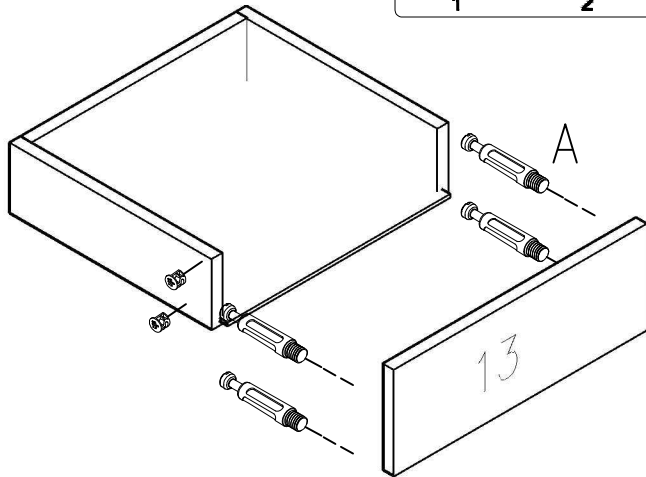
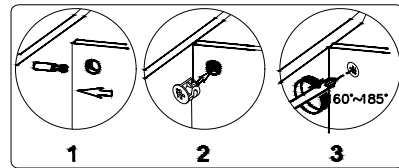



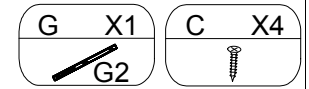
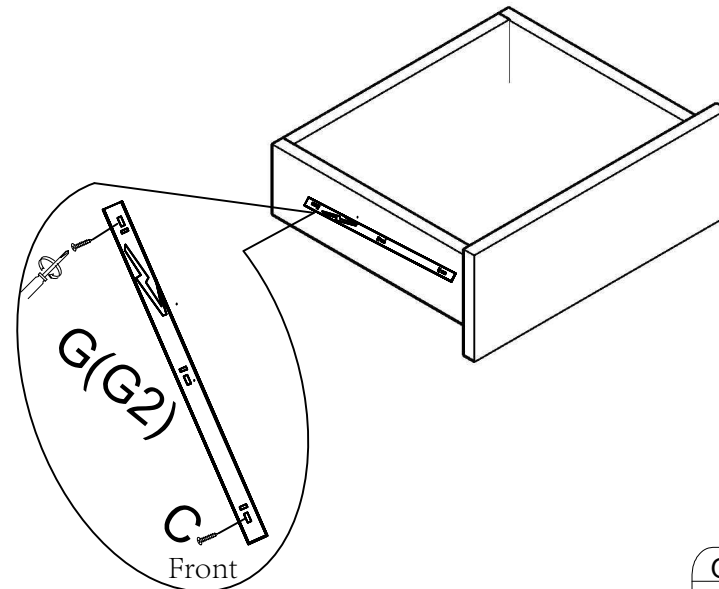

10

X2

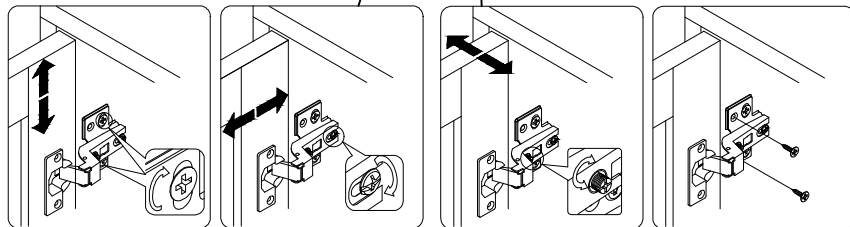
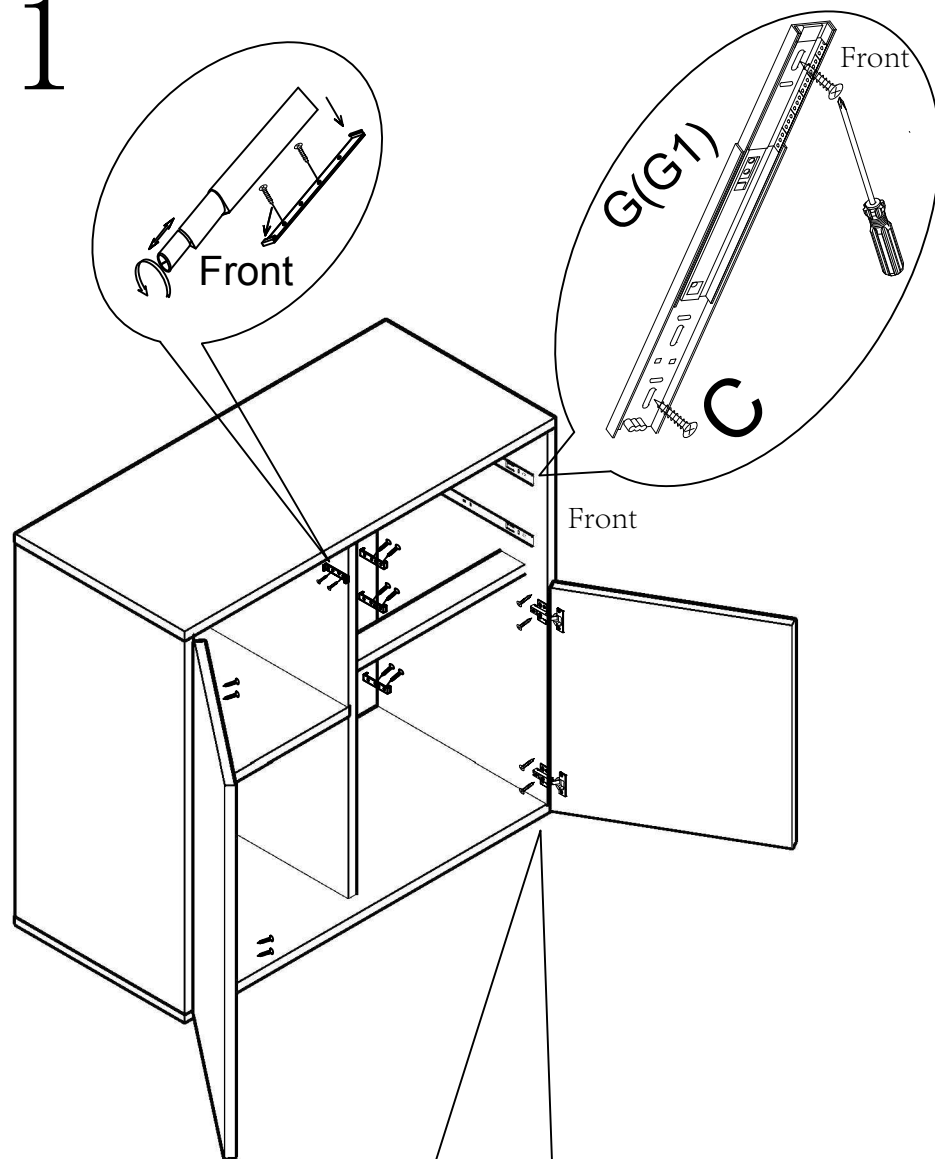

11



G	X2	C	X24	I	X4
					

12

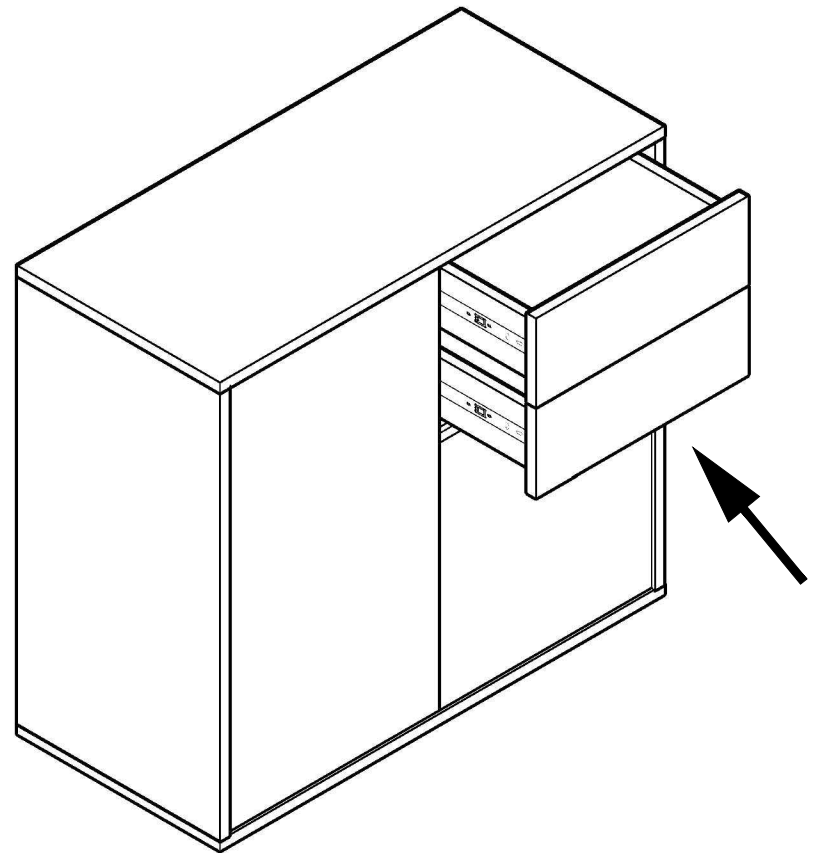

13

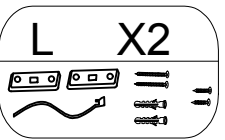
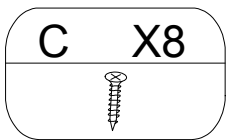
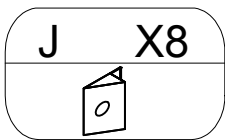
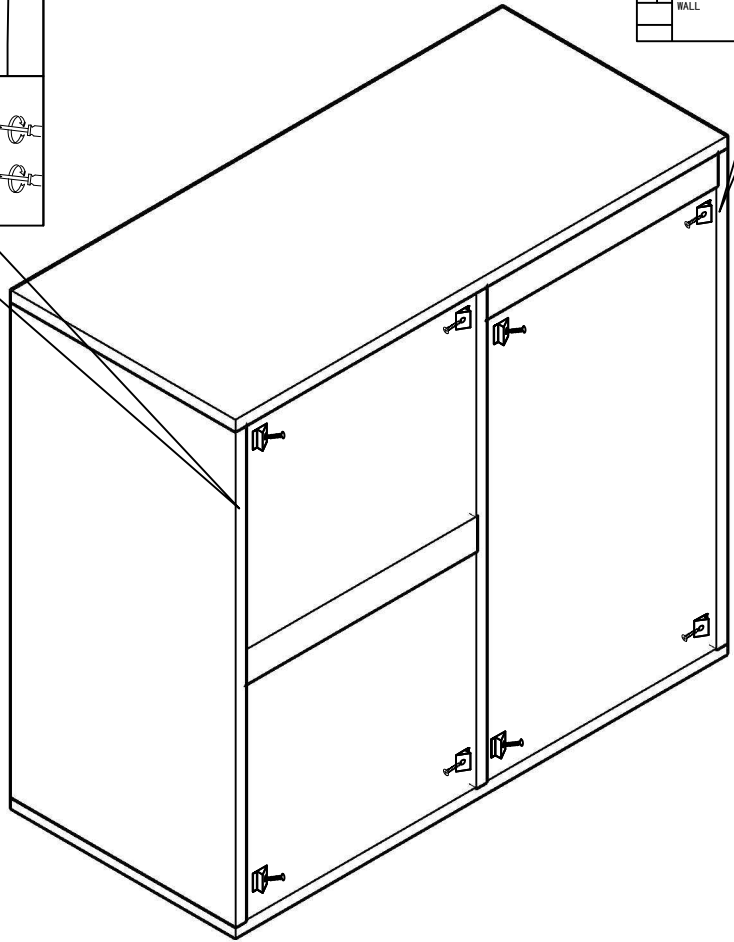
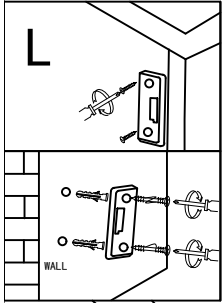
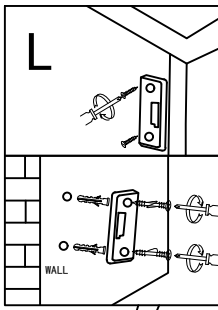
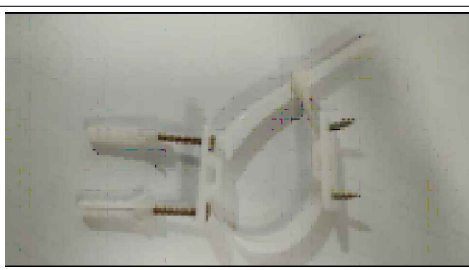

14

Finally, 1/2/3 the protective film on the surface needs to be removed !

