

# INSTRUCTION MANUAL

AIR97

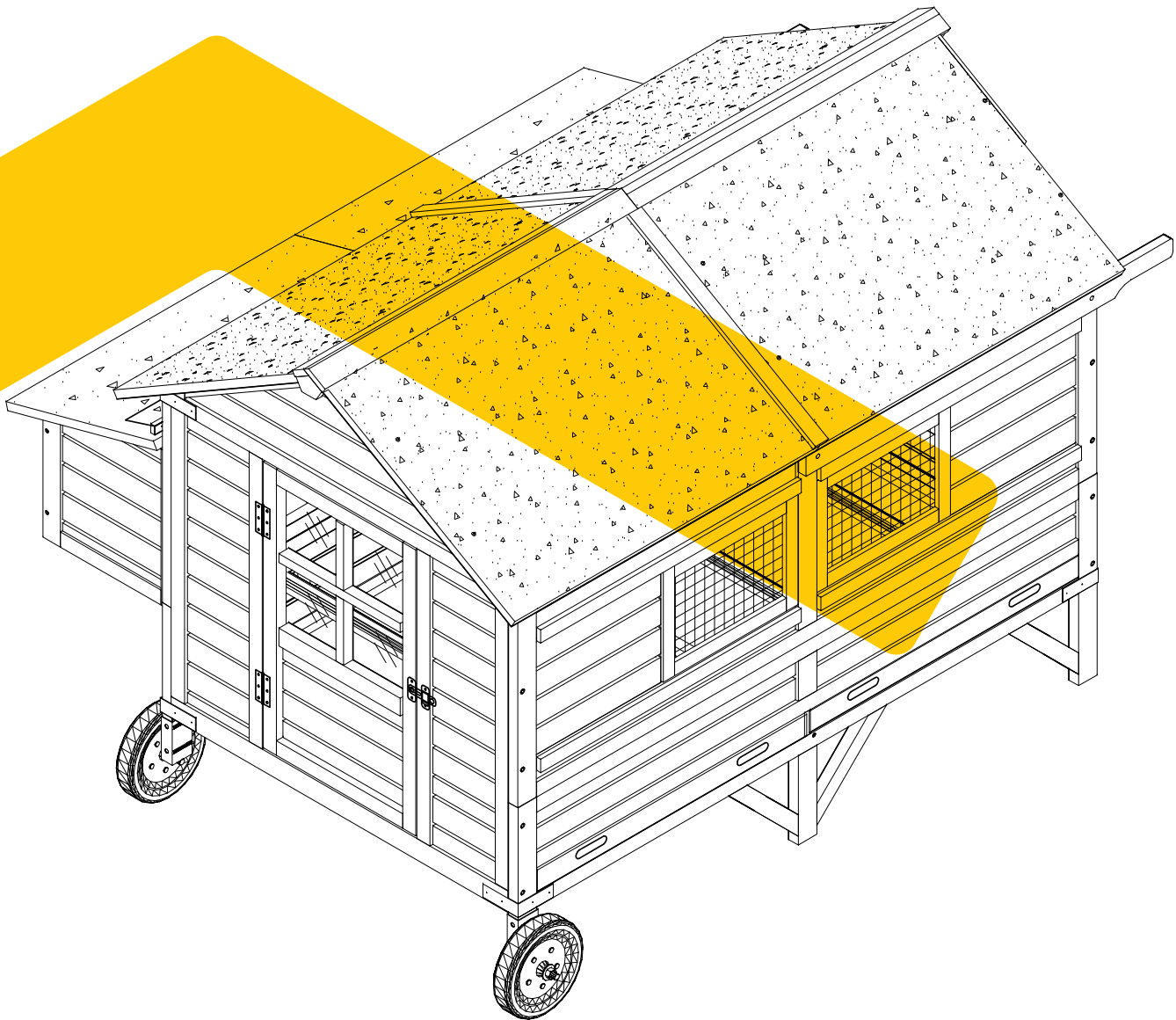





## NOTICE

Please retain these instructions for future

- Firmly secure all bolts, screws and knobs before use.
- Reconfirm that all bolts, screws, and knobs are secure every 90 days.
- Fasten screws loosely during initial assembly. Do not fully tighten screws until the item is completely assembled.
- Do not use or store this item in the proximity of open flame or flammable/combustible chemicals.
- Be aware that some parts are heavy and have sharp edges.
- Be aware that moving parts can injure, crush and cut.
- If any parts are missing, broken, damaged, or worn, stop using this product until repairs are made and/or factory replacement parts are installed.
- Do not use this item in a way inconsistent with the manufacturer's instructions as this could void the product warranty.

# TOOLS REQUIRED



PHILLIPS  
SCREWDRIVER

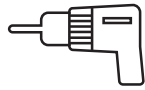

DRILL  
(RECOMMENDED)



2PERSON  
ASSEMBLY



APPROXIMATELY  
60MIN. ASSEMBLY

# HARDWARE

M6.0x60mm BOLT  
4 PCS+1 spare



P1

M6.0x55 mm SCREW  
12PCS+1 spare



P2

M3.5x60 mm SCREW  
4PCS+1 spare



P3

M3.5x45 mm SCREW  
34PCS+1 spare



P4

M3.5x35 mm SCREW  
16PCS+1 spare



P5

M3.5x30 mm SCREW  
2 PCS+1 spare



P6

M3.5x25 mm SCREW  
38PCS+1 spare



P7

M3.0x16 mm SCREW  
70PCS+1 spare



P8

# HARDWARE

Spring latch  
1PC

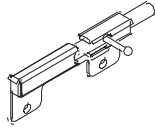

P9

L shape corner bracket  
8PCS



P10

Casters  
2PCS

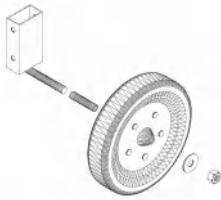

P11

Corner bracket  
4PCS



P12

PVC  
1PC

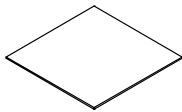

P13

Lock  
2PC

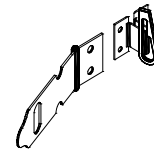

P14

# PARTS

## CARTON 1/3

left side panel-Upper  
1PC



**A**

left side panel-Down  
1PC



**B**

Right side panel-Upper  
1PC



**C**

Right side panel-Down  
1PC



**D**

Push handle  
2PCS



**J**

Front panel of nesting box  
2PCS



**M**

Connect Bar  
1PC

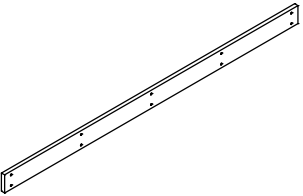

**U**

Hardware bag



**P1 P2 P3 P4 P5 P6**

# PARTS

## CARTON 2/3

Front panel  
1PC



**E**

Back panel  
1PC



**F**

Waterproof Strip  
2PCS



**S**

Perch  
4PCS



**H**

Bottom panel of nesting box  
2PCS



**N**

Divider  
2PCS

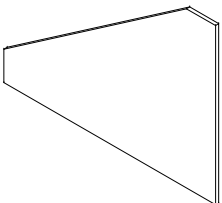

**O**

Roof of nesting box  
2PCS

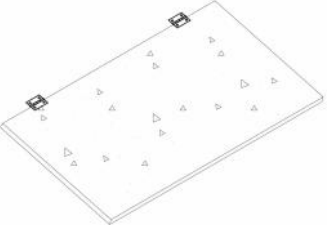

**P**

PVC Waterproof Strip  
2PCS



**T**

Tray Support  
1PC

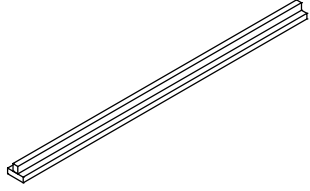

**V**

# PARTS

## CARTON 2/3

Support  
2PCS

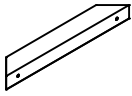

W

# PARTS

## CARTON 3/3

Tray  
2PCS

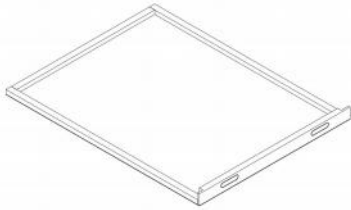

**G**

Panel of nesting box  
2PCS



**K**

Panel of nesting box  
2PCS

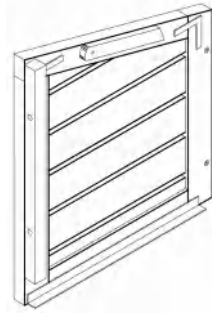

**L**

Roof support  
1PC



**I**

Roof  
4PCS

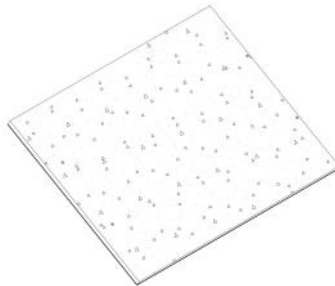

**Q**

Roof cap  
2PCS

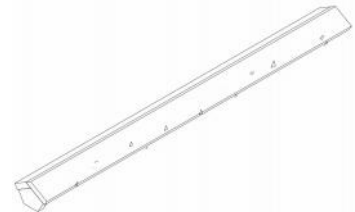

**R**

# PRODUCT ASSEMBLY

## 01

Attach the side panels.

Attach the Part C, Part D with connect bar Part U by 10 X P7 screws, and then attach the corner bracket P12 by 4 X P8 screws each side.

Attach the Part A, Part B by 4 X P3 screws in middle, and then attach the corner bracket P12 by 4 X P8 screws each side.

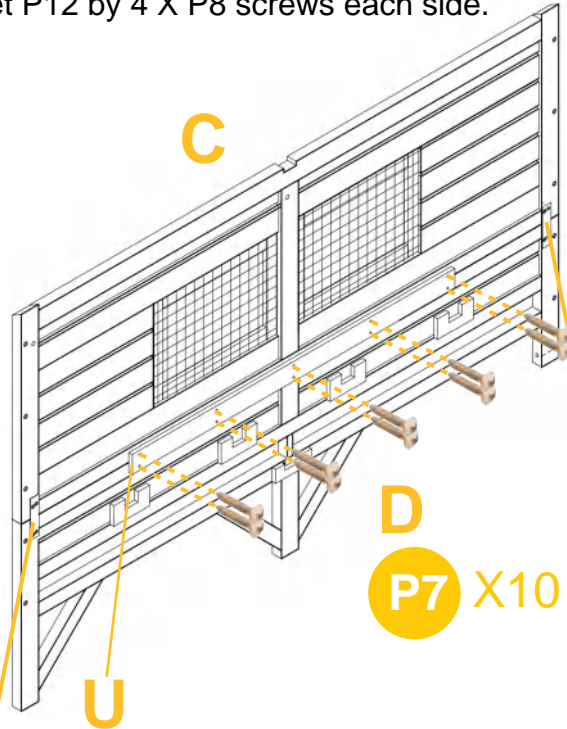

Pls note: The corner bracket need to be screwed on the inside edge

Pls note: The corner bracket need to be screwed on the inside edge

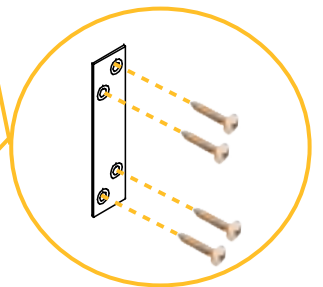
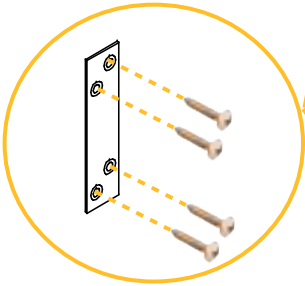
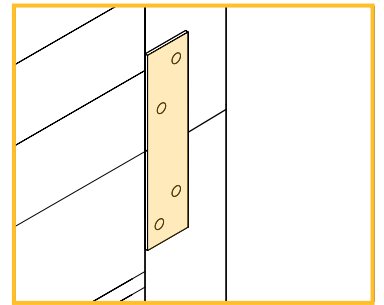
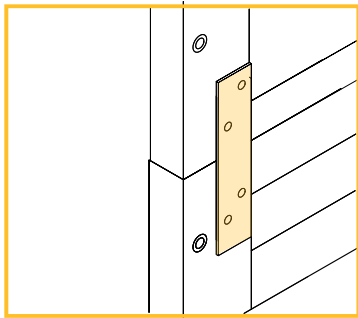

P12 X2

P8 X8

A

B

P3 X4

D

P7 X10

U

C

P12 X2

P8 X8

## PRODUCT ASSEMBLY

# 02

Install the casters.

Attach the casters P11 to the side panel by 2 X P1 screws each side. (Notice the direction of side panel Part A & Part C )

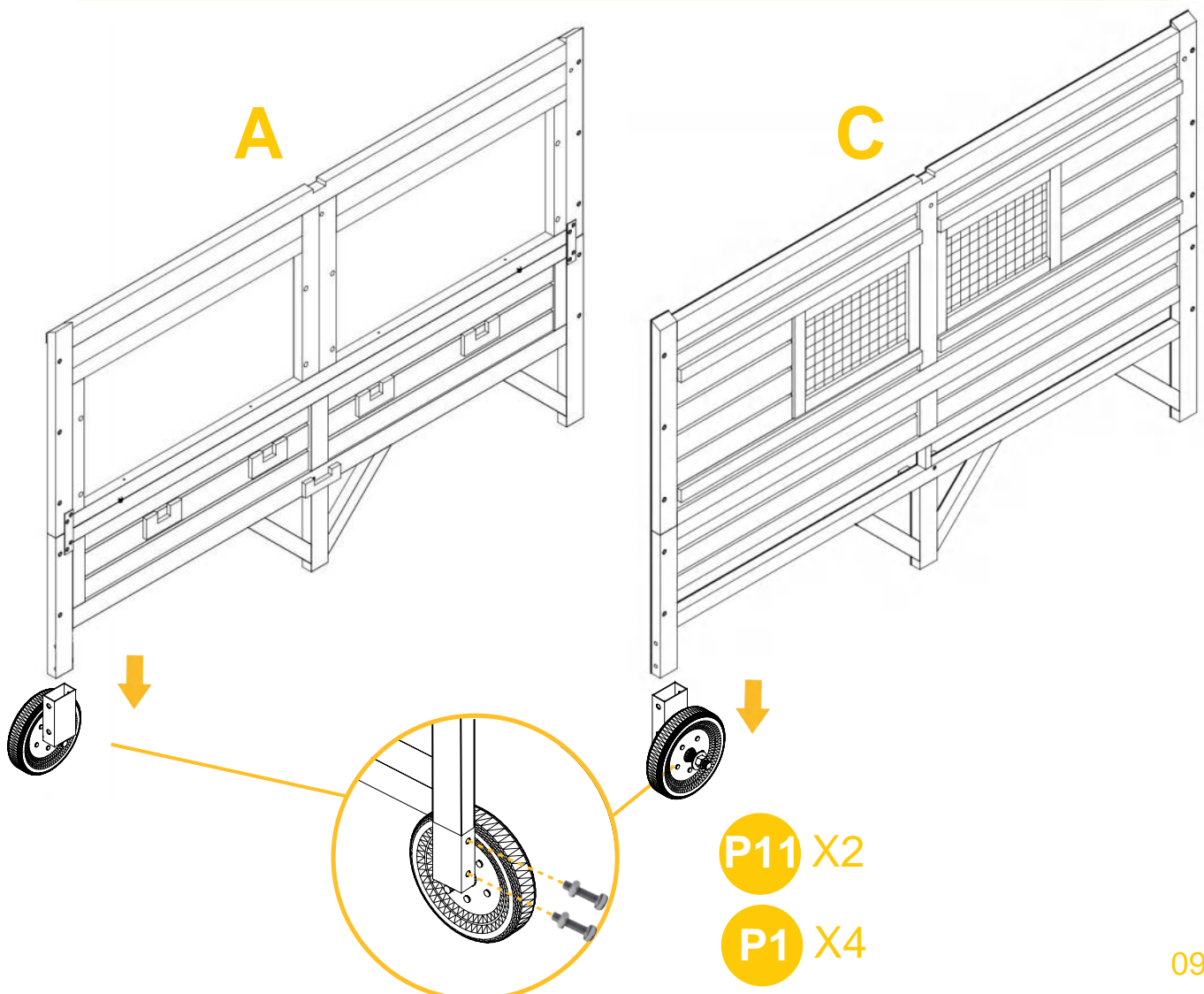
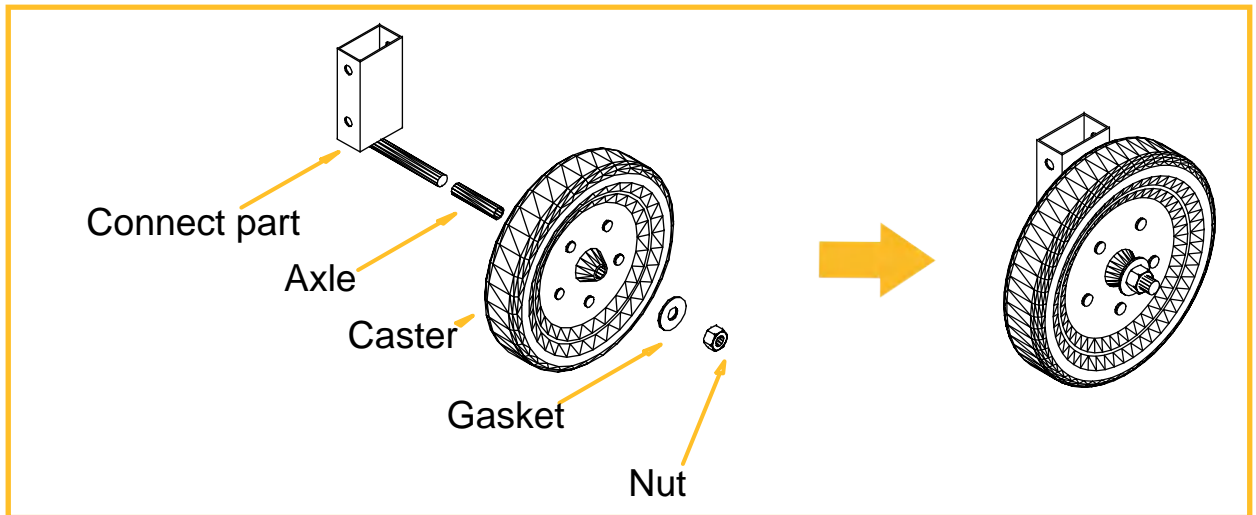

# PRODUCT ASSEMBLY

## 03

Attach the Part E, Part F to Side Panel by 5 X P4 screws each side. Attach the corner bracket P10 to the corner by 4xP8 each side. Insert the tray support Part V into the slots inside two side panels, and then screw it by 2 X P4 screws.

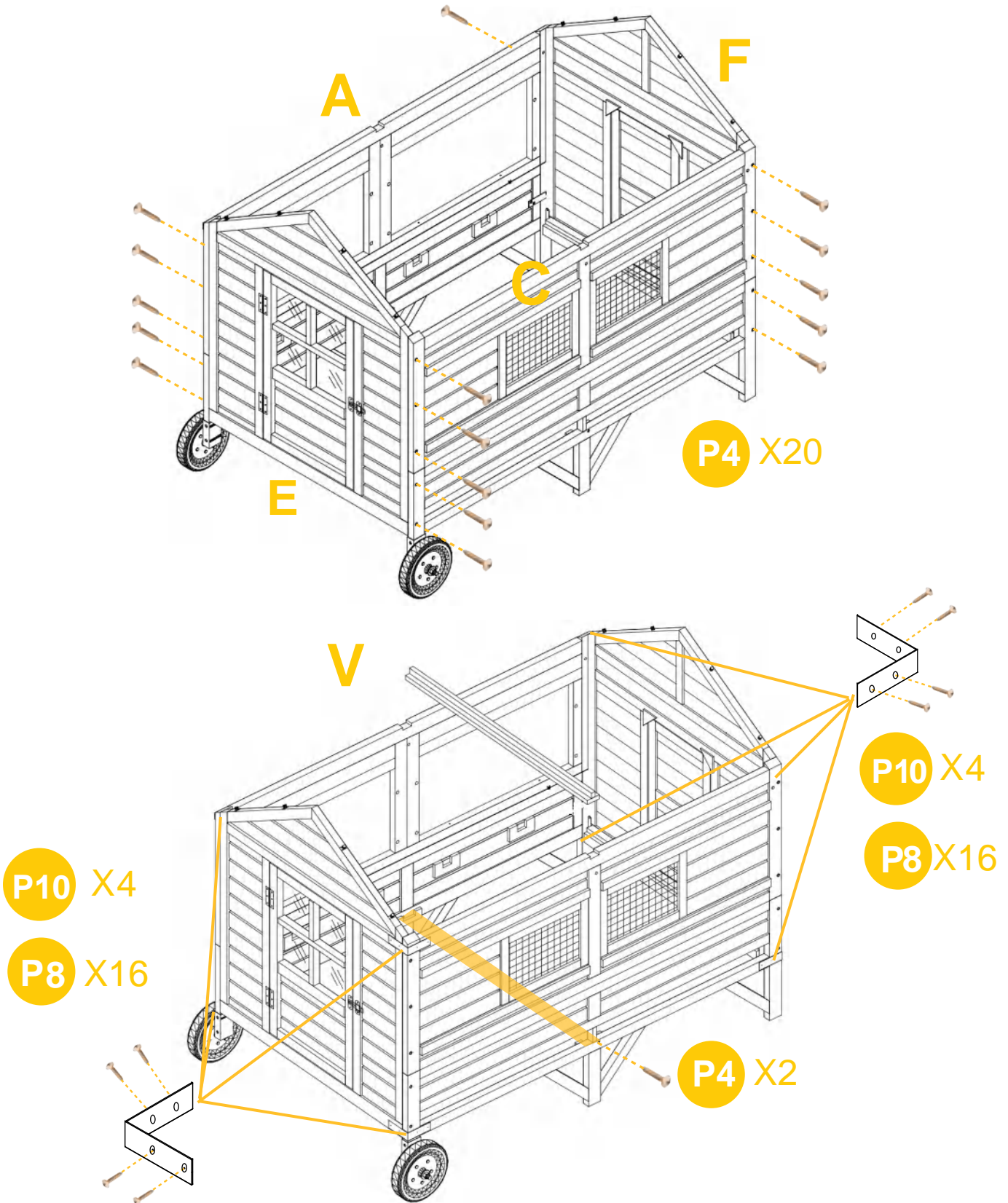

## PRODUCT ASSEMBLY

- 04** Insert 4PCS perches Part H into the slots inside two side panels.  
Slide in tray Part G in side.

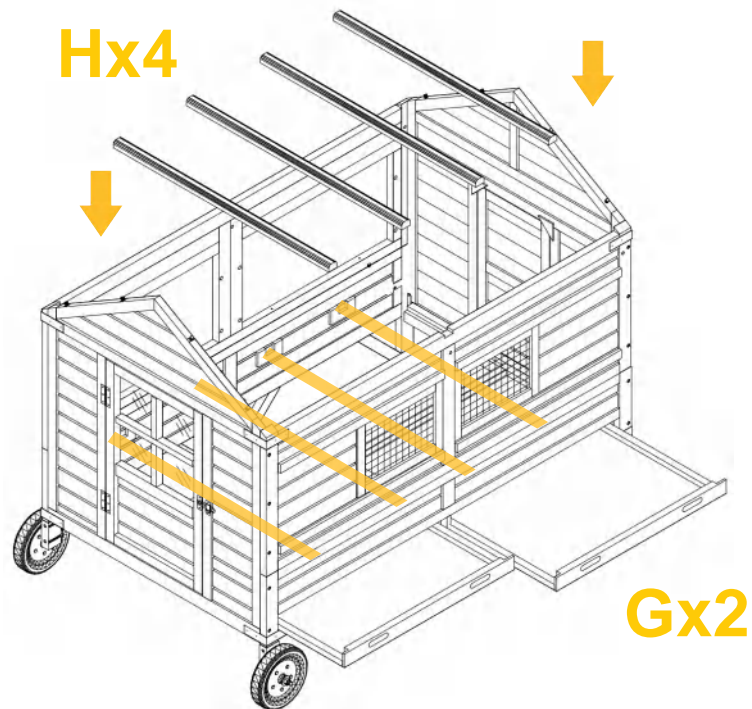

- 05** Attached the roof support Part I by 2XP6 screws.

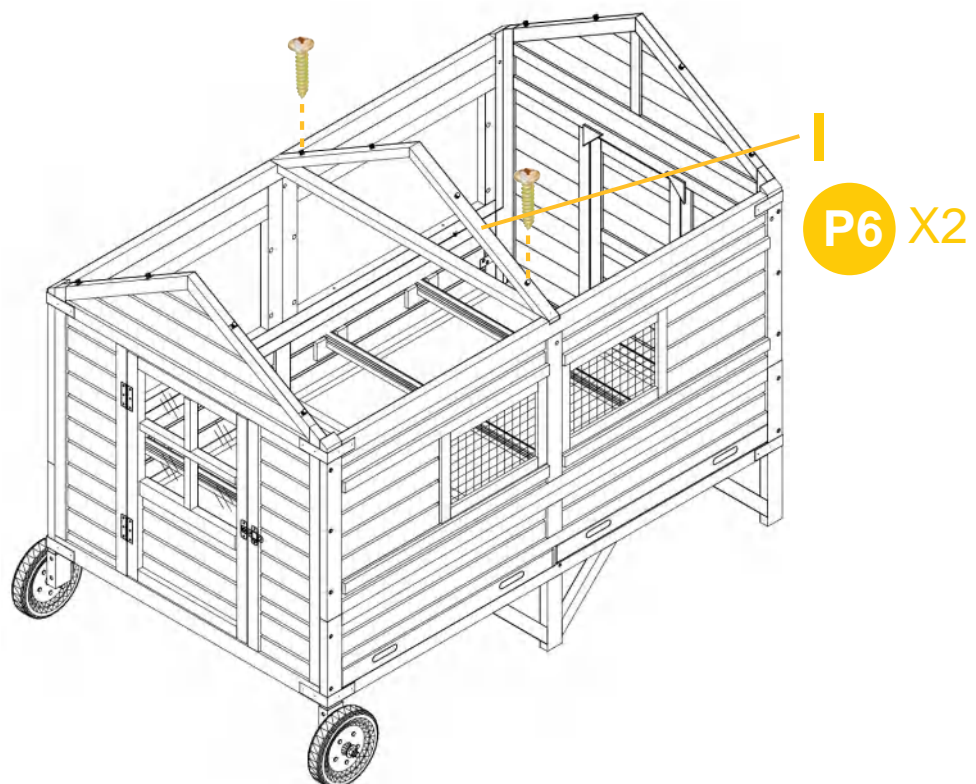

## PRODUCT ASSEMBLY

**06** Attached the push handle Part J to the coop by 2XP2 bolts each side.

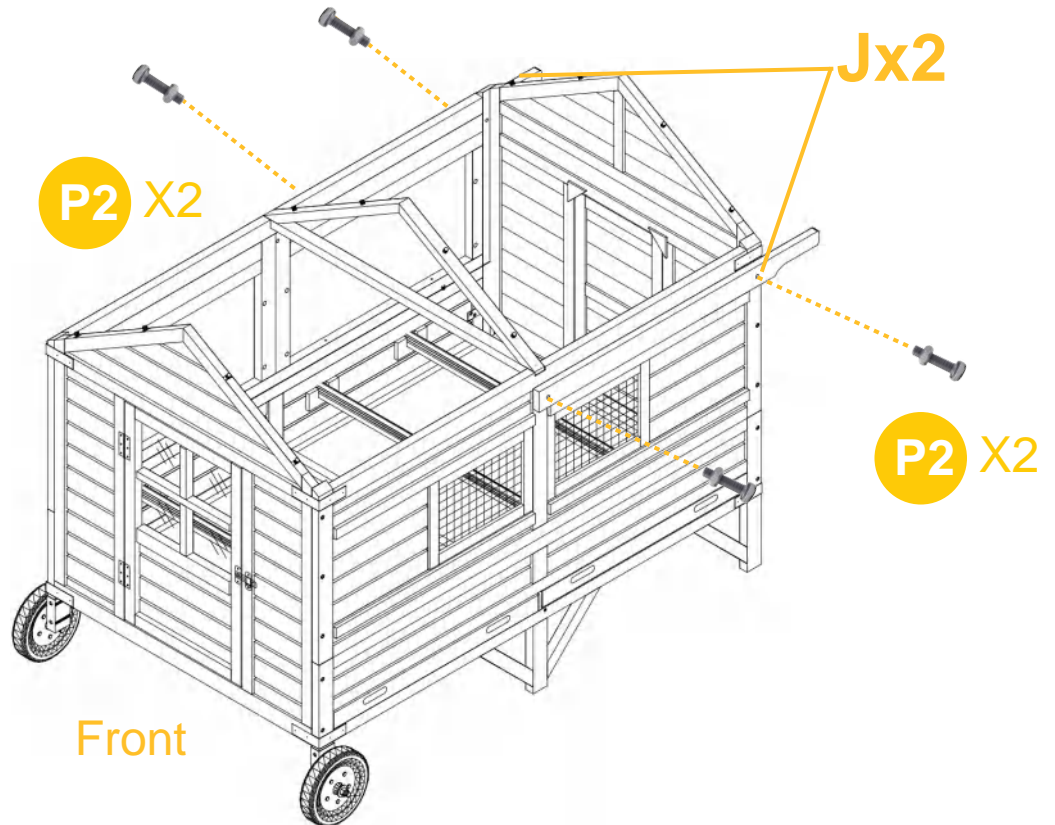

**07** Attach the nesting box (Two nesting boxes)  
Attach the Part K & Part L & Part M by 8XP4 screws. (Notice the direction of Part K & Part L )

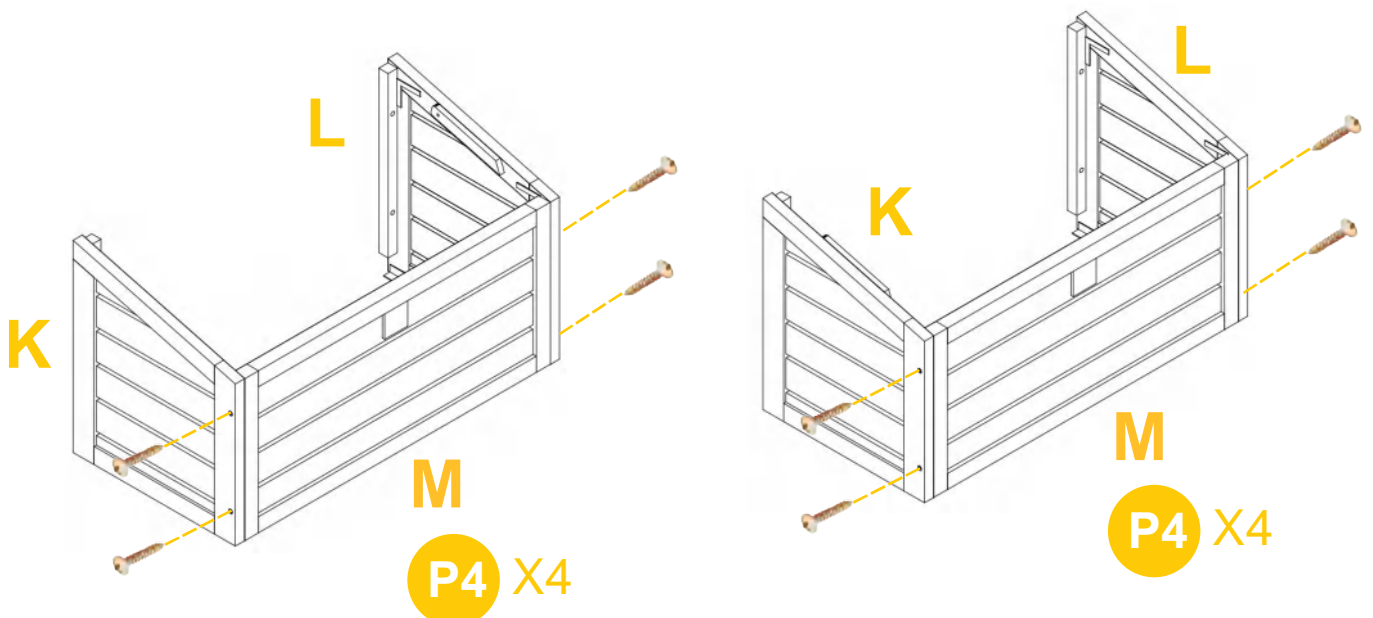

## PRODUCT ASSEMBLY

08

Attach the nesting box to the coop by 8XP2 bolts.  
Attach the support Part W to coop by 2 X P4 screws each side

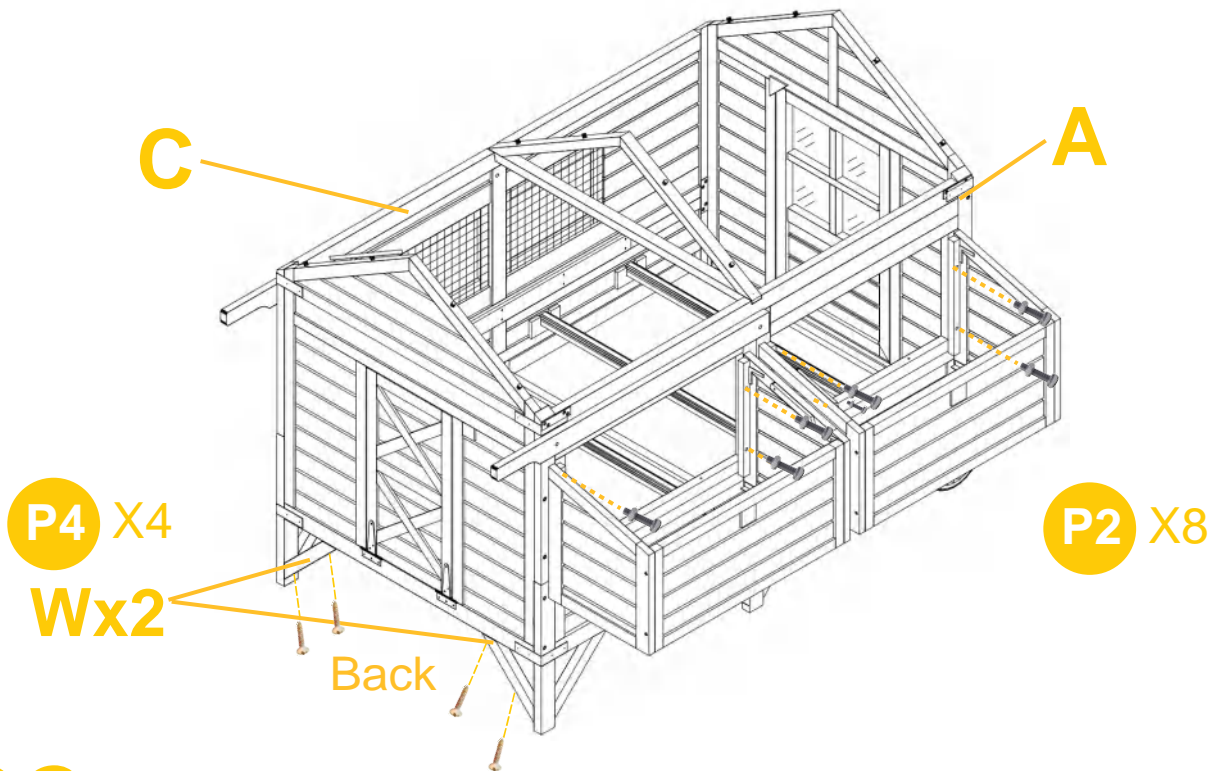

09

Insert the divider Part O into the slots of bottom floor Part N.  
Drop in the bottom floor Part N to the nesting box each side.

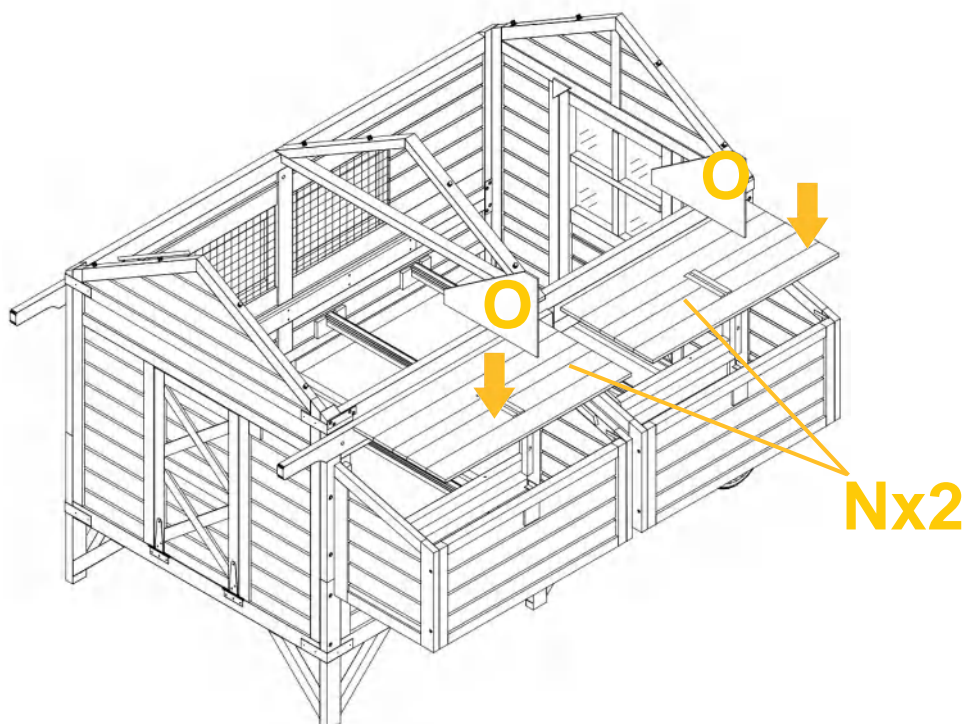

## PRODUCT ASSEMBLY

- 10** Attach the nesting box roof Part P by 8XP8 screws.  
Attach the latch P9 to back door by 2 X P8 screws.

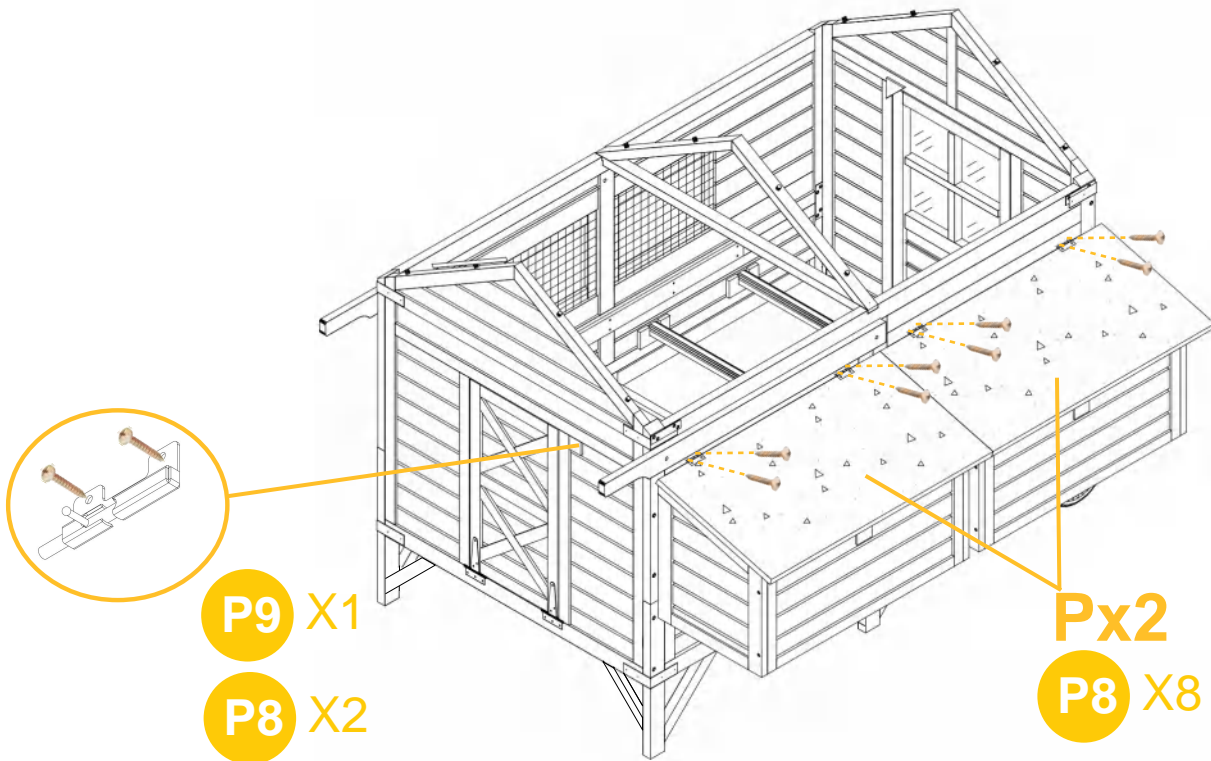

- 11** Attached PVC Waterproof Strip Part T to the nesting box by 8XP7 screws.

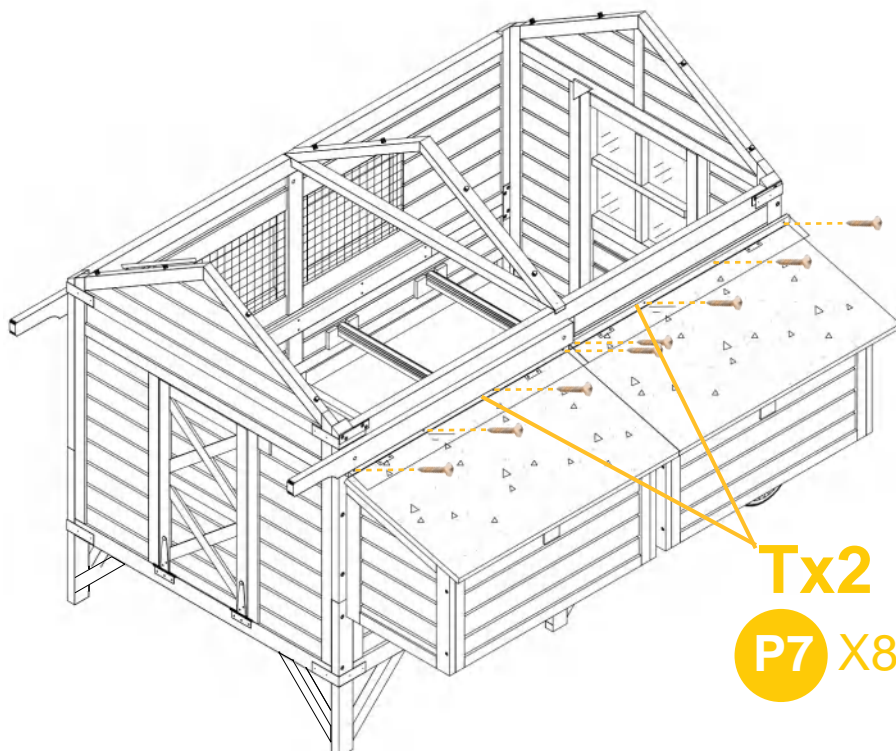

# PRODUCT ASSEMBLY

# 12

Pls reference below 4 steps to screw the lock P14.

Pls exact locate the pre drilled holes on the roof side to screw the part of lock P14 by 2xP8 each roof.

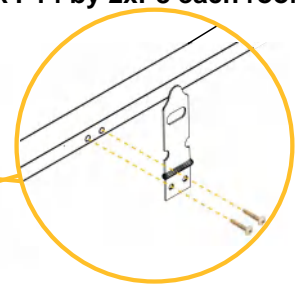
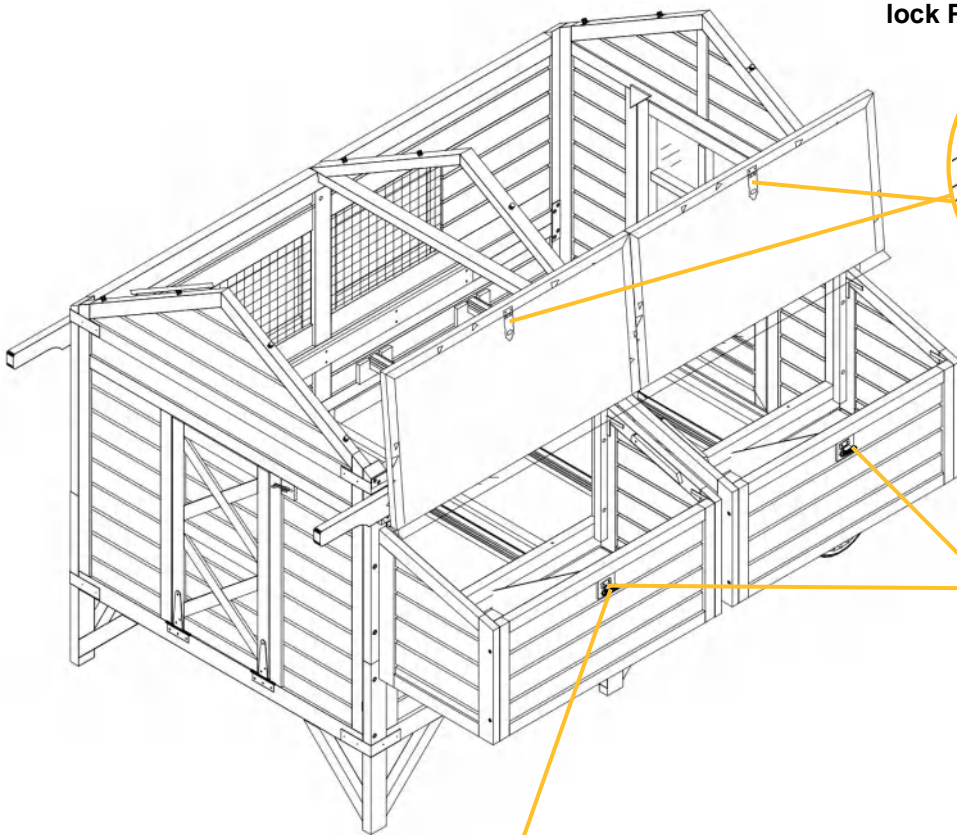

**P14** X2

**P8** X4

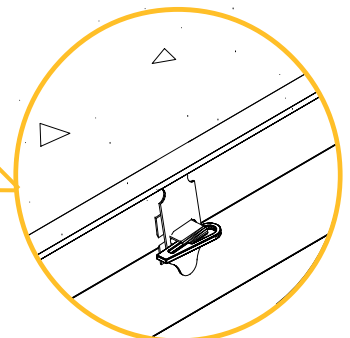

Close the roof to mark the exactly position of the matched lock on front panel.

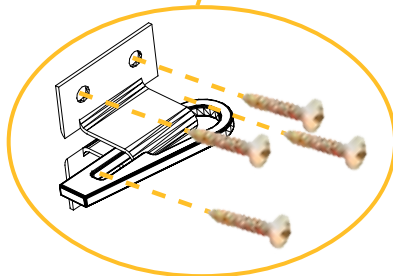

**P8** X8

Screw the matched lock to the front panel in mark position by 4xP8 screws each.

Close roof to make sure the 2 sides lock can match to work well. If not ,pls re-screw and adjust

## PRODUCT ASSEMBLY

**13** Attach the coop roof Part Q by 16XP5 screws.

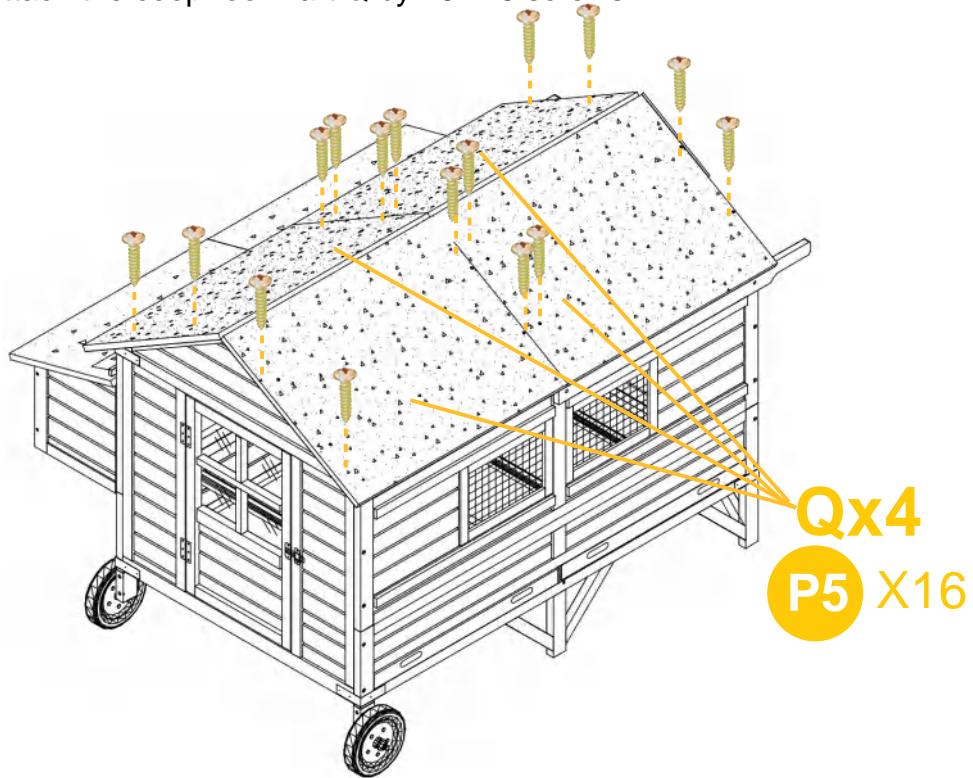

**14** Put the Waterproof pvc P13 in the connection position of 2 roof cap to avoid the water leakage. Ensure top roof panels line up with each other before screwing the cap 2XPart R by 8XP7 Screws.

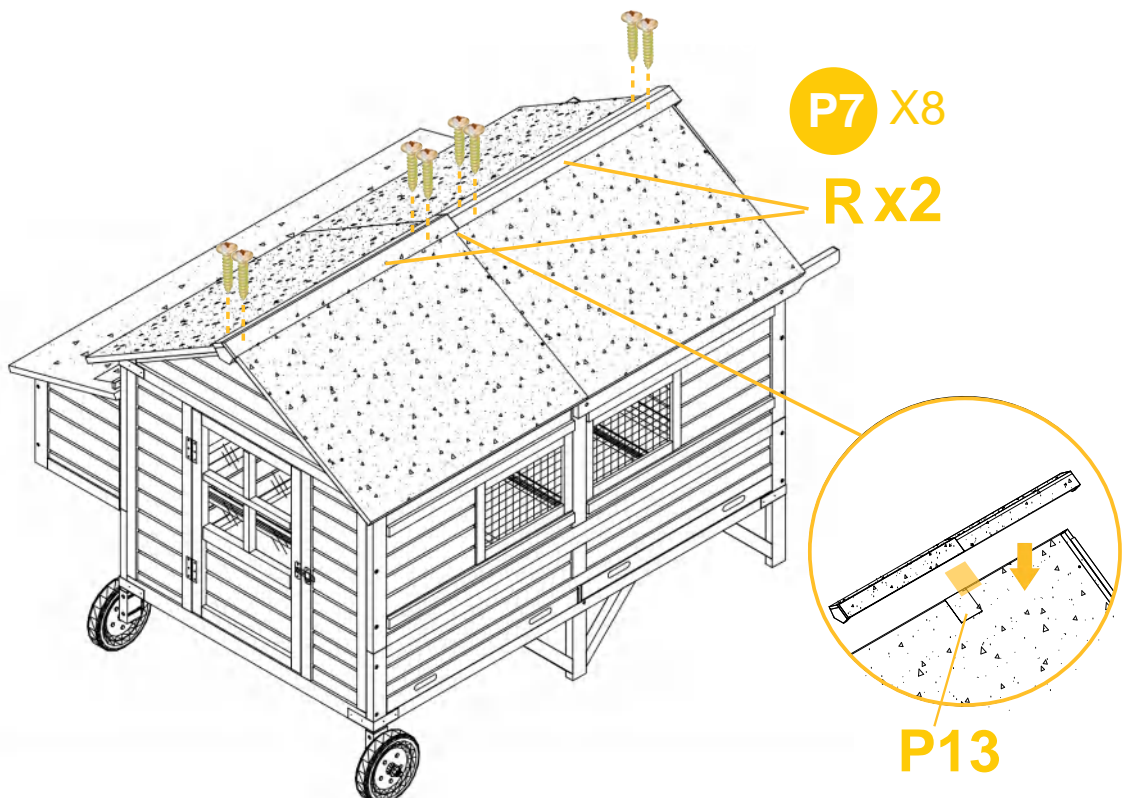

## PRODUCT ASSEMBLY

**15** Connect the roof with Waterproof Strip 2xPart S by 12xP7 screws..

**P7** X12

**Sx2**

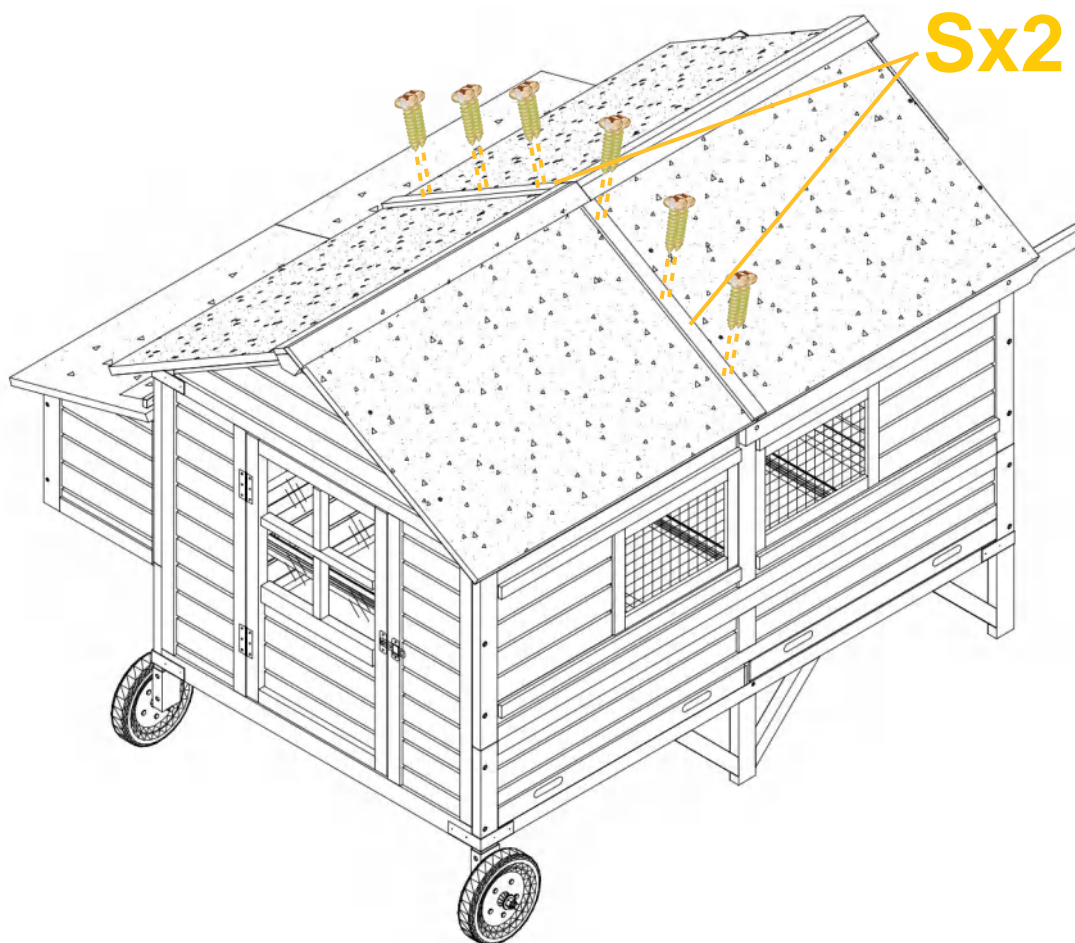

Finish



**WARNING**

Manufacturer and seller expressly disclaim any and all liability for personal injury, property damage or loss, whether direct, indirect, or incidental, resulting from the incorrect attachment, improper use, inadequate maintenance, or neglect of this