

# **Installation Manual of Bed**

Full & Queen Size

## **Dear Valued Customer:**

Thank you for choosing our brand and purchasing our bed frame!

We are thrilled to have earned your trust and we want to ensure that you are completely satisfied with your purchase. To help you get the most out of your new bed frame, we would like to share some useful tips on cleaning and maintenance.

When cleaning your bed frame, we recommend using a soft, slightly moist cloth. Avoid using corrosive detergents, wire brushes, abrasive scourers, or any sharp metal objects as they may damage the product.

Additionally, we recommend checking the components of the bed frame regularly to ensure that all screws are tightened and the frame remains stable.

Installing the bed frame is a simple process. Please refer to the detailed instructions in the manual for step-by-step guidance.

Customer satisfaction is our top priority and we are committed to providing you with the best service and high-quality products. If you have any questions or concerns regarding your bed frame, please don't hesitate to contact our customer service team at email. We are here to help you and resolve any issues you may have. To solve your problem faster, please note the following information in the email.

Contact : [AMZ11service@outlook.com](mailto:AMZ11service@outlook.com).

Theme: Beds Service

Content: Name-XXX

Order ID Number: xxx-xxxxxxx-xxxxxxx

Once again, we would like to express our gratitude to you for choosing our product. Your trust and support mean the world to us. We look forward to continuing to provide you with the best products and services possible.

Best Regards,

Customer Service Team

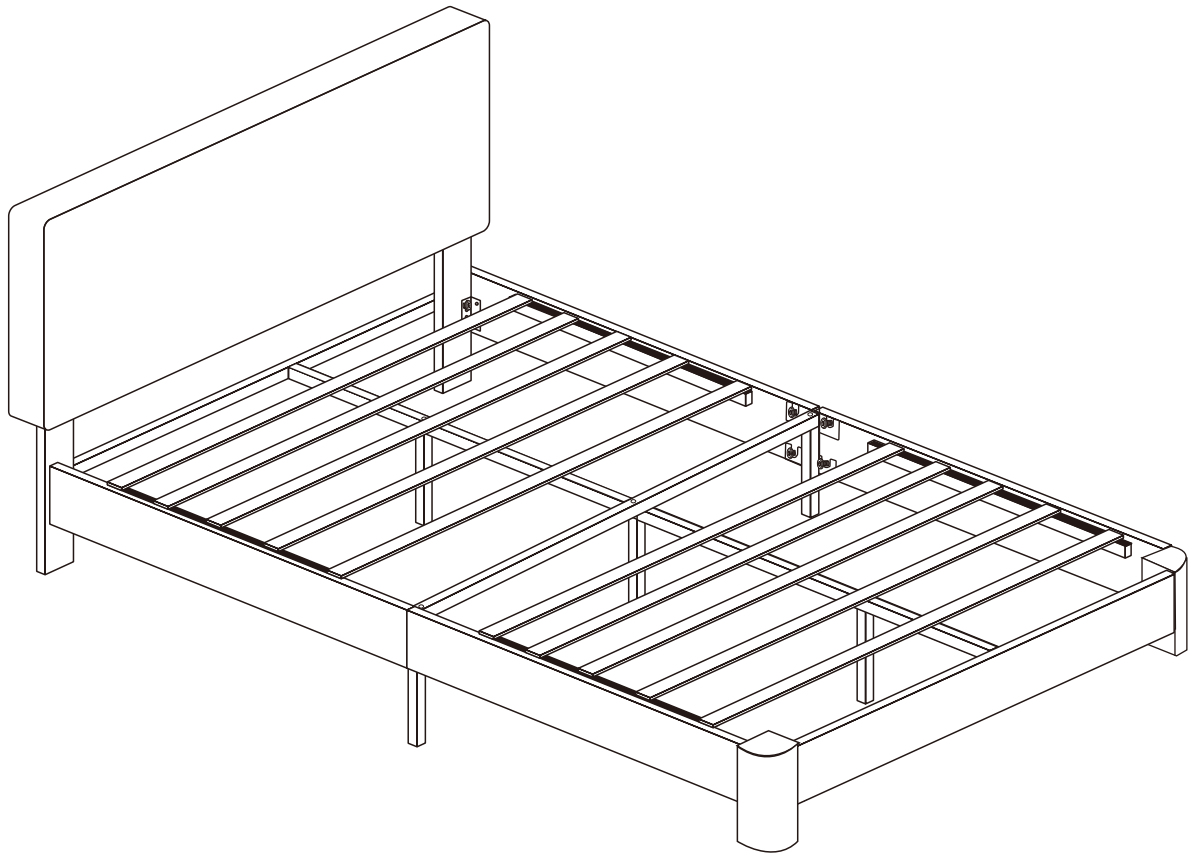

## IMPORTANT NOTE

1. Please check that all parts are complete before installation.
2. Please strictly follow the installation steps to install.
3. Please install the bed on a clean and smooth surface to prevent any damage.
4. Please do not use the power tools to assemble the bed.
5. Please periodically check all the fittings and re-tighten as necessary.
6. Please do not use the bed unless all bolts and screw are firmly secured.
7. Please contact us if you need any help, we will reply you in six hours.

## Important tips:

Don't tighten the screws first, make sure all parts are installed before tightening the screws.

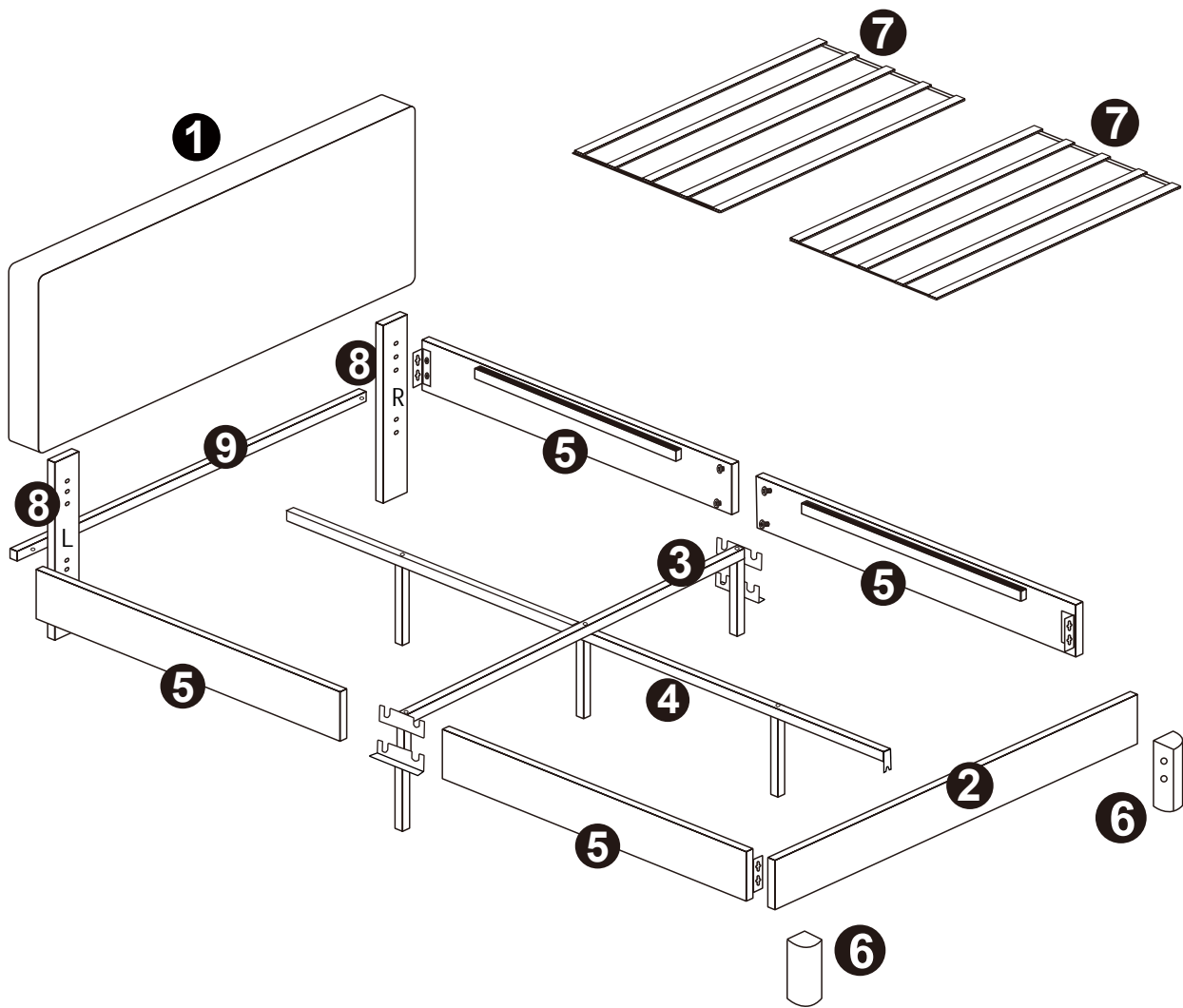

## PART LIST

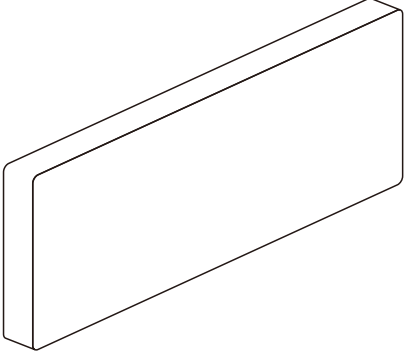
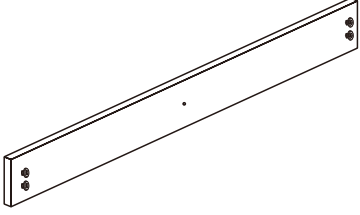
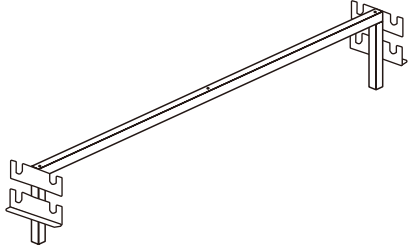
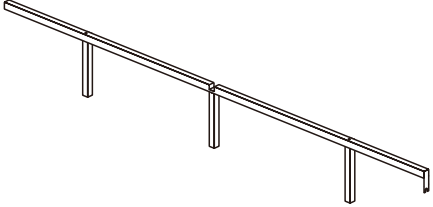
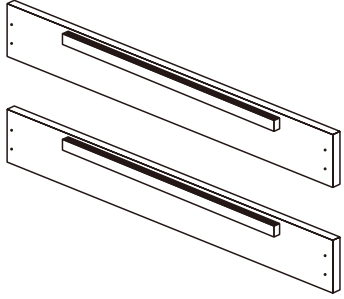
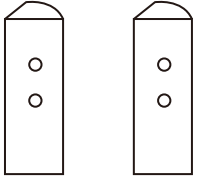
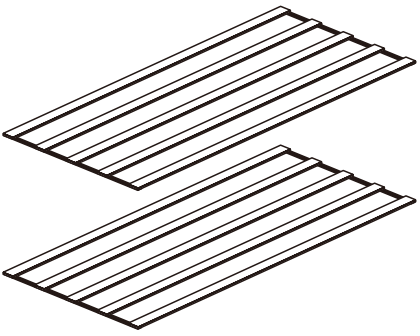
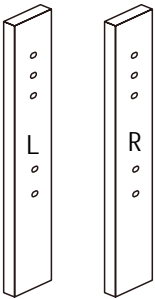
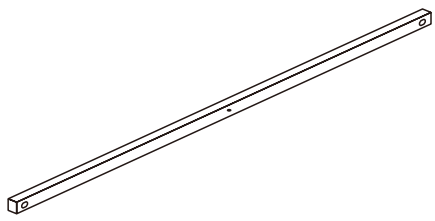
<p>(1) Headboard panel x 1pcs</p> 	<p>(2) Tailboard x 1pcs</p> 	<p>(3) Transverse center x 1pcs</p> 
<p>(4) Center support bar x 1pcs</p> 	<p>(5) Side panel x 4pcs</p> 	<p>(6) Leg with anti-slip gasket x 2pcs</p> 
<p>(7) Slat x 2pcs</p> 	<p>(8) Headboard support x 2pcs</p> 	<p>(9) Headstock bar x 1pcs</p> 

## PART LIST

<p>H1: Bolt M8x16mm x 33pcs</p>  <p>H2: Bolt M8x40mm x 11pcs</p>  <p>H3: Bolt M8x50mm x 1pcs</p>  <p>Bolt M8x16mm Spare parts x 1pcs          Bolt M8x40mm Spare parts x 1pcs          Bolt M8x50mm Spare parts x 1pcs</p>	<p>(H5) Allen Key M5 x 2pc          (Installation tool)</p> 	<p>Hanging piece</p> 
---	---	--

Step 1 Lay the headboard (1) flat on the clean floor, put the headboard support frame (8) on it, and tighten it with (H2) and (H5).

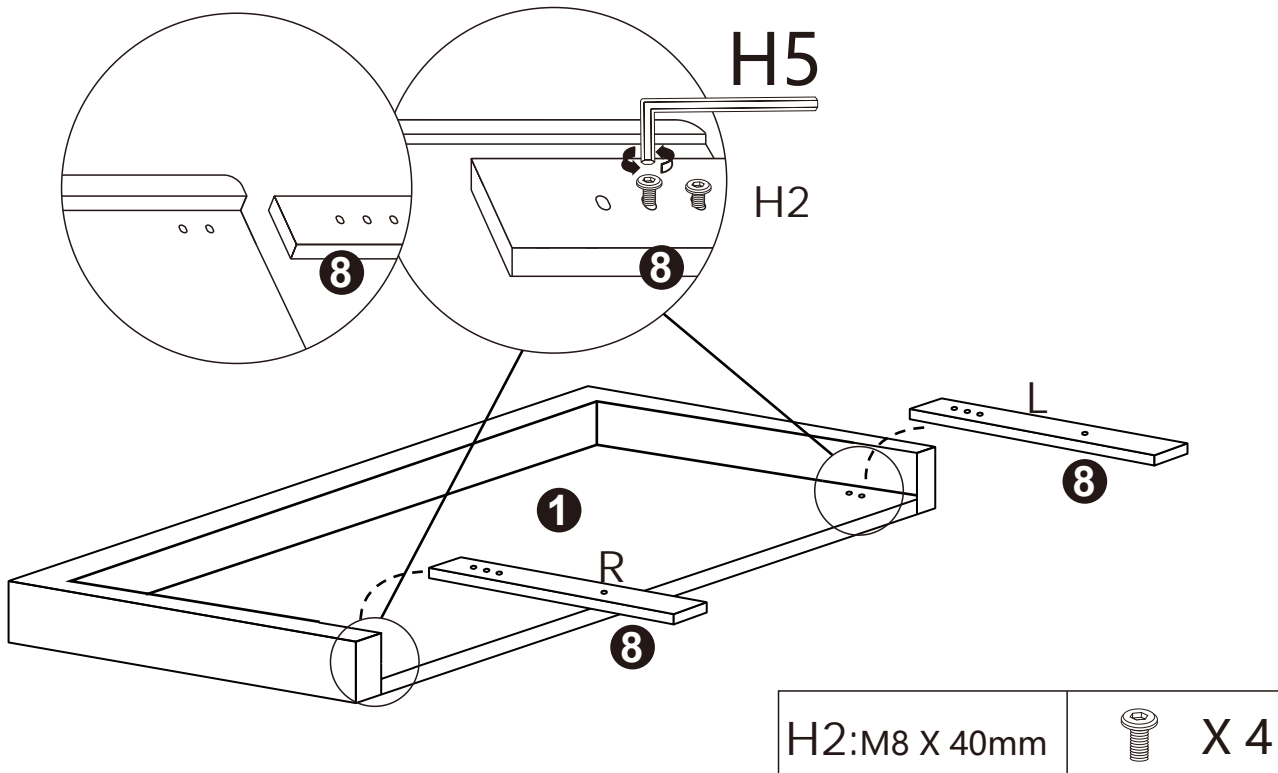

Step 2 Two heights can be adjusted.

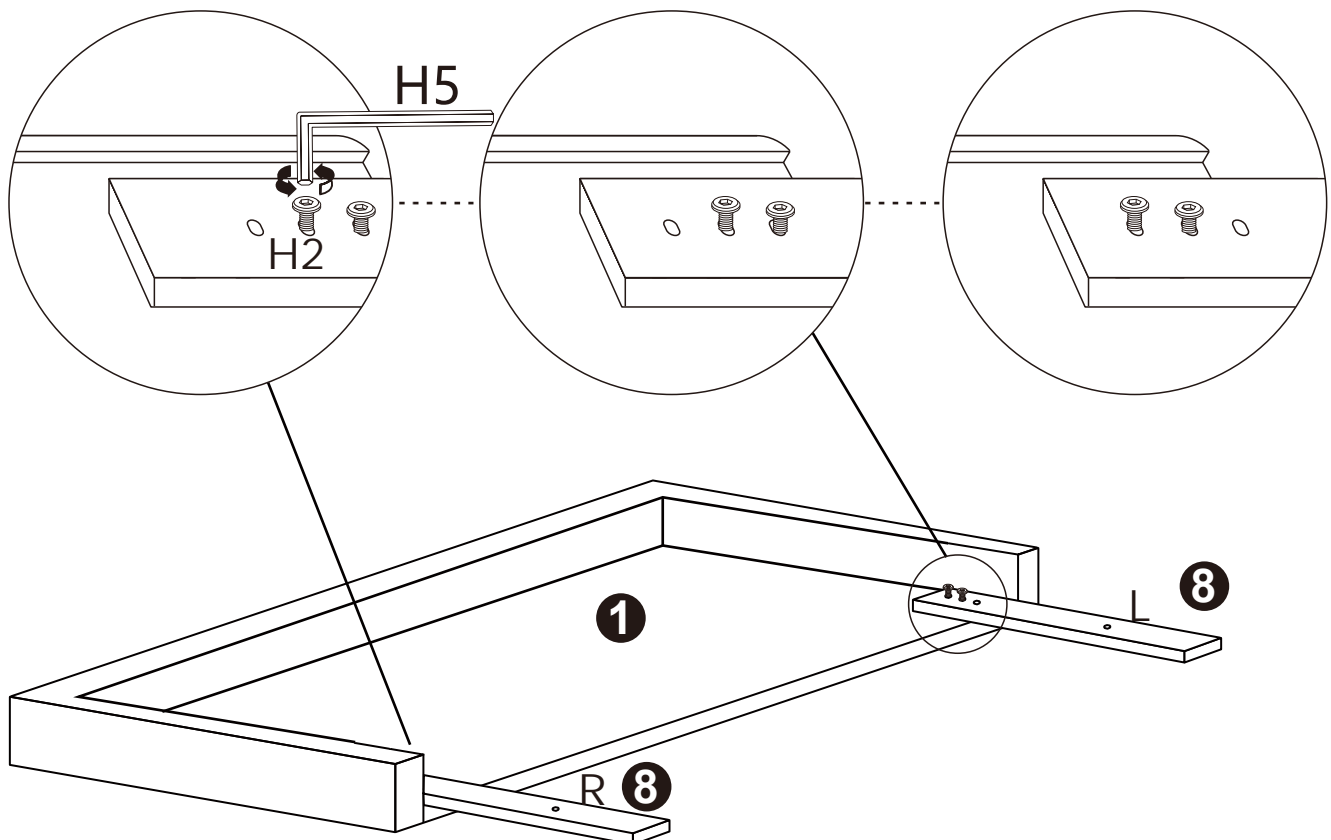

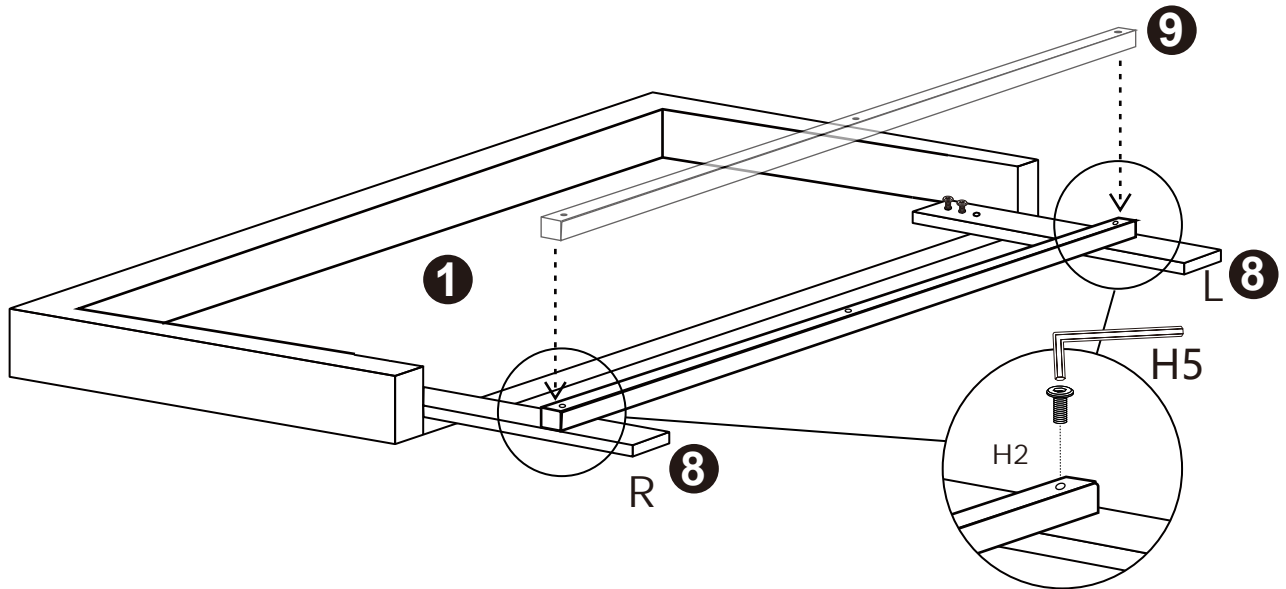

Step 3 Place the crossbar (9) on the bed foot (8) and tighten it with (H2) screws.

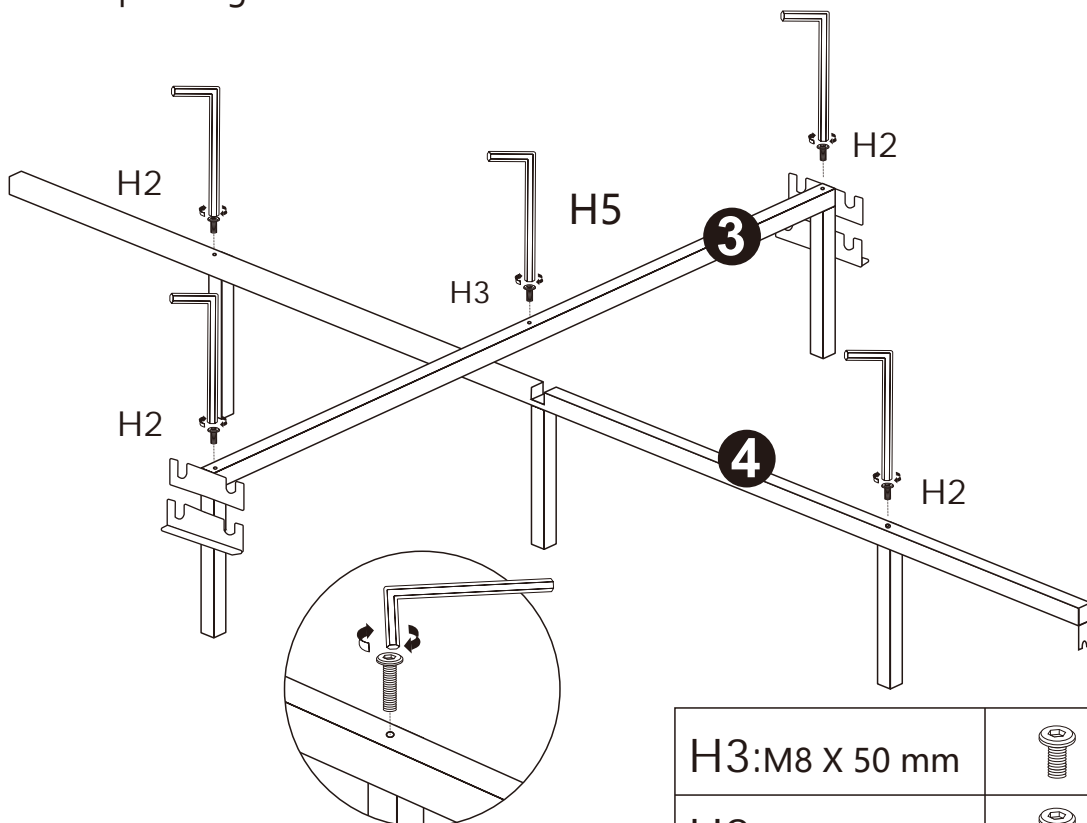

H2:M8 X 40mm	 X 2
--------------	---

Step 4 Open part (3) and part (4), place part (3) on top of part (4), and tighten the corresponding screws.



H3:M8 X 50 mm	 X 1
H2:M8 X 40 mm	 X 4

Step 5 Tighten the bracket into the hole on the upper tail plate (2) using a 16 mm screw.

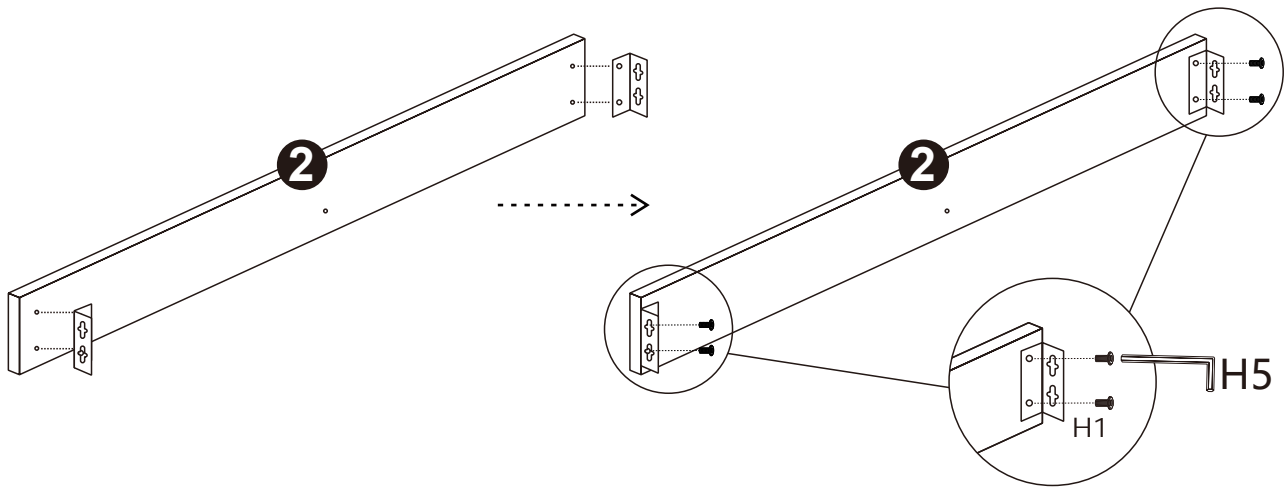

Hanging piece		X 2
H1:M8 X 16mm		X 4

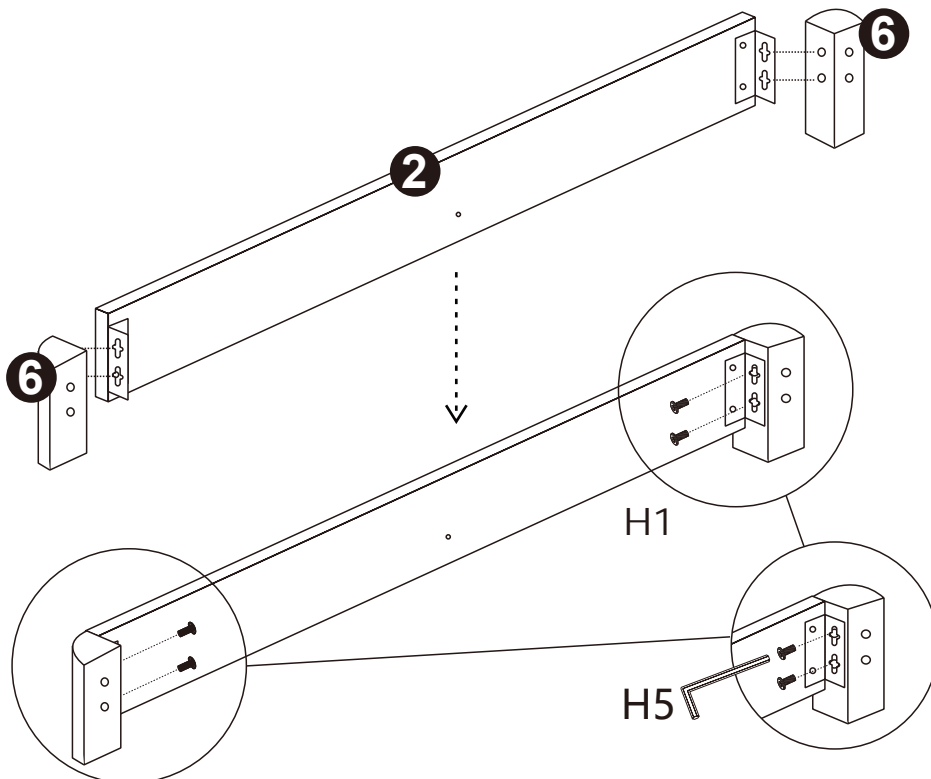

Step 6 Align the bed legs (6) to the holes on the upper bed footboard and tighten them with (H1) screws.

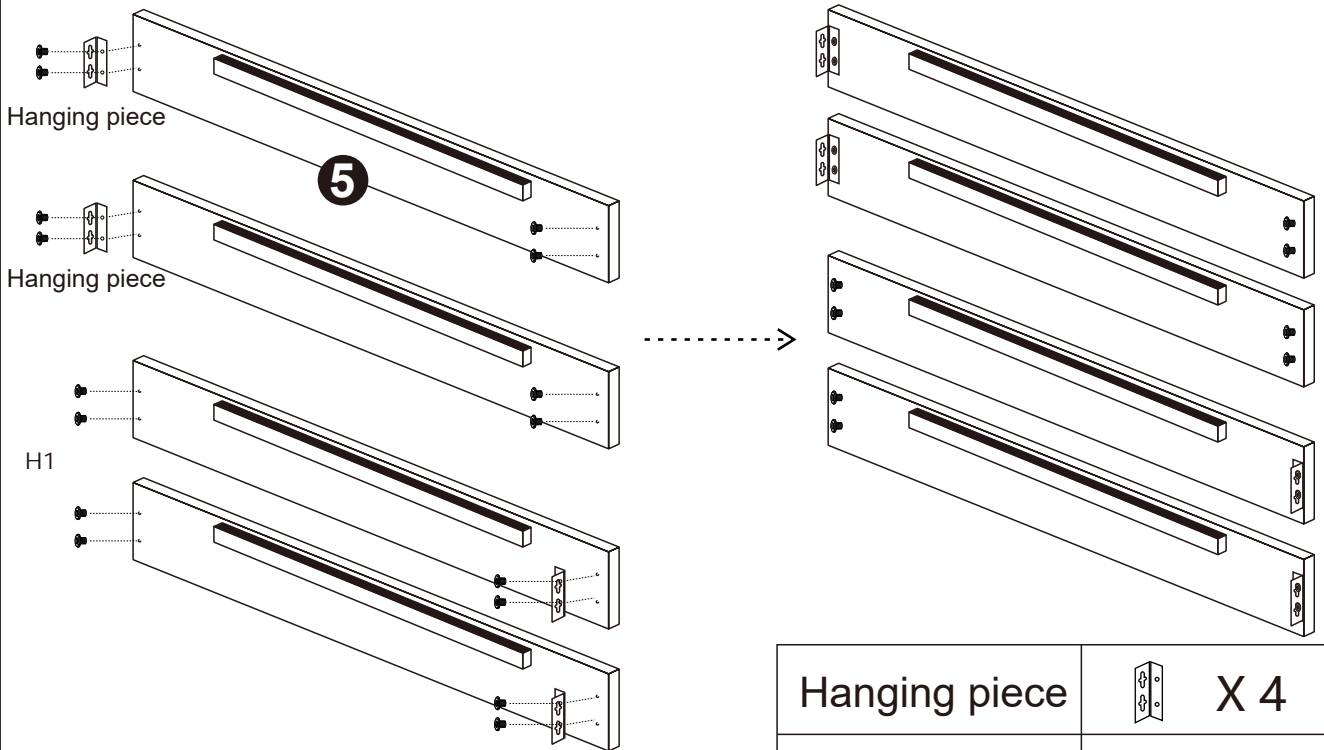

H1:M8 X 16mm		X 4
--------------	---	-----

Step 7 The two bed side panels have a lock plate on the left and screws on the right, and the other two bed side panels have a lock plate on the right and screws on the left.



Hanging piece		X 4
H1:M8 X 16mm		X 16

Step 8 Screw the (H1) screws into the front holes of the bed legs (8).

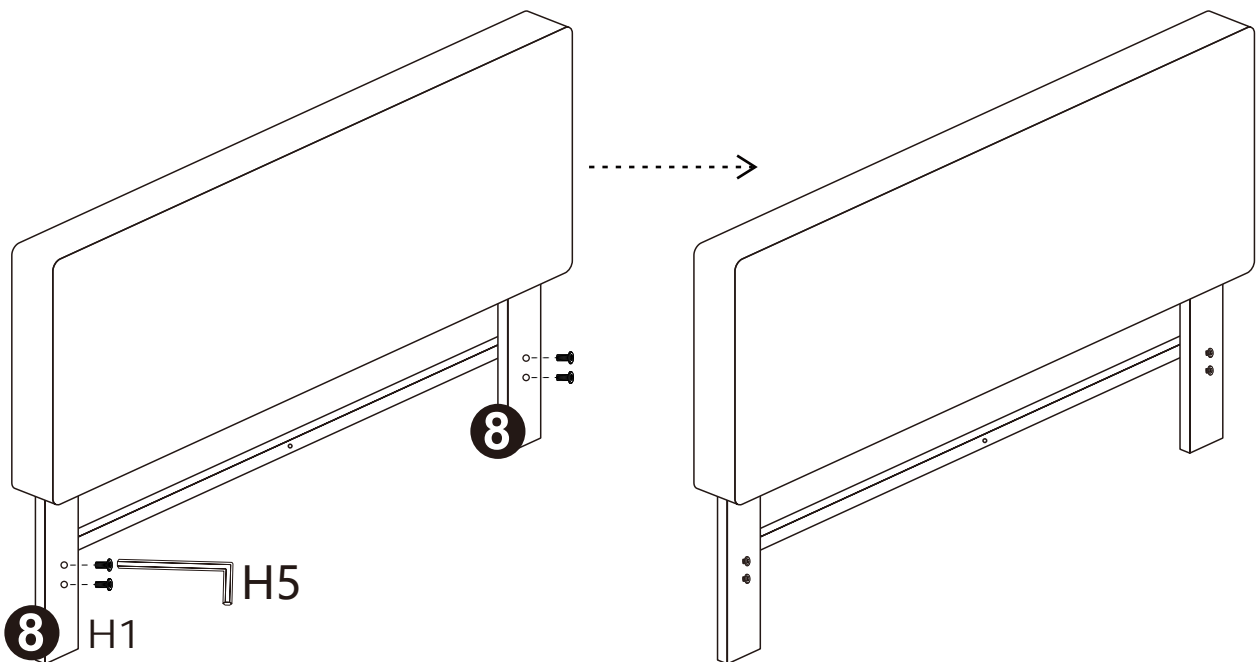

H1:M8 X 16mm		X 4
--------------	---	-----

Step 9 Put the accessories installed in step (4), step (6), and step (8) together according to the figure below, and tighten the corresponding screws.

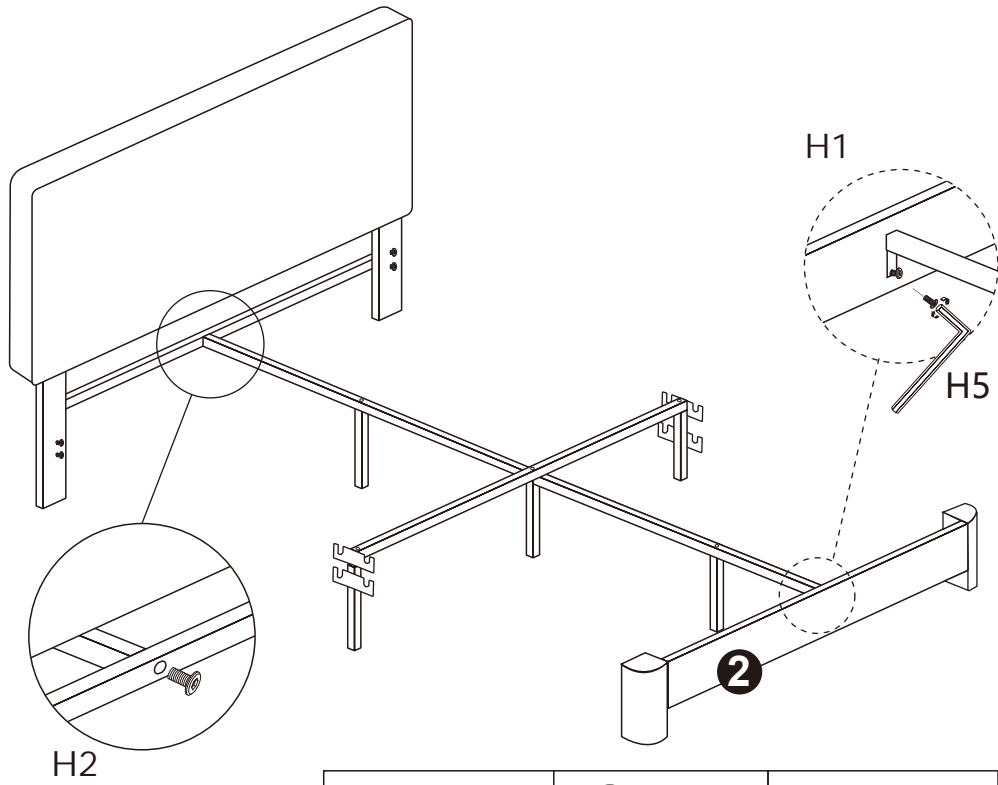

H2:M8 X 40mm

 X 1

H1:M8 X 16mm

 X 1

Step 10 Position part (5) as shown in the diagram and tighten the screws.

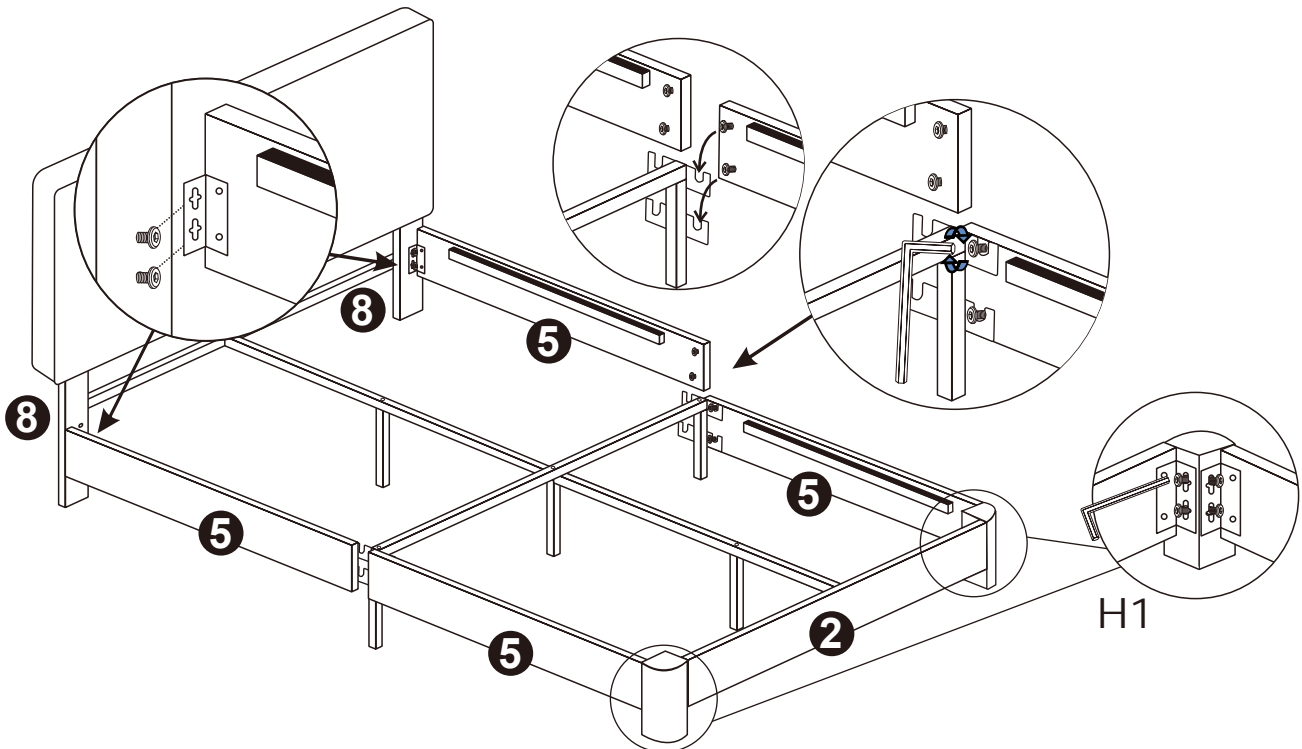

H1:M8 X 16mm

 X 4

Step 11 Open part (7) and place it on part (5)

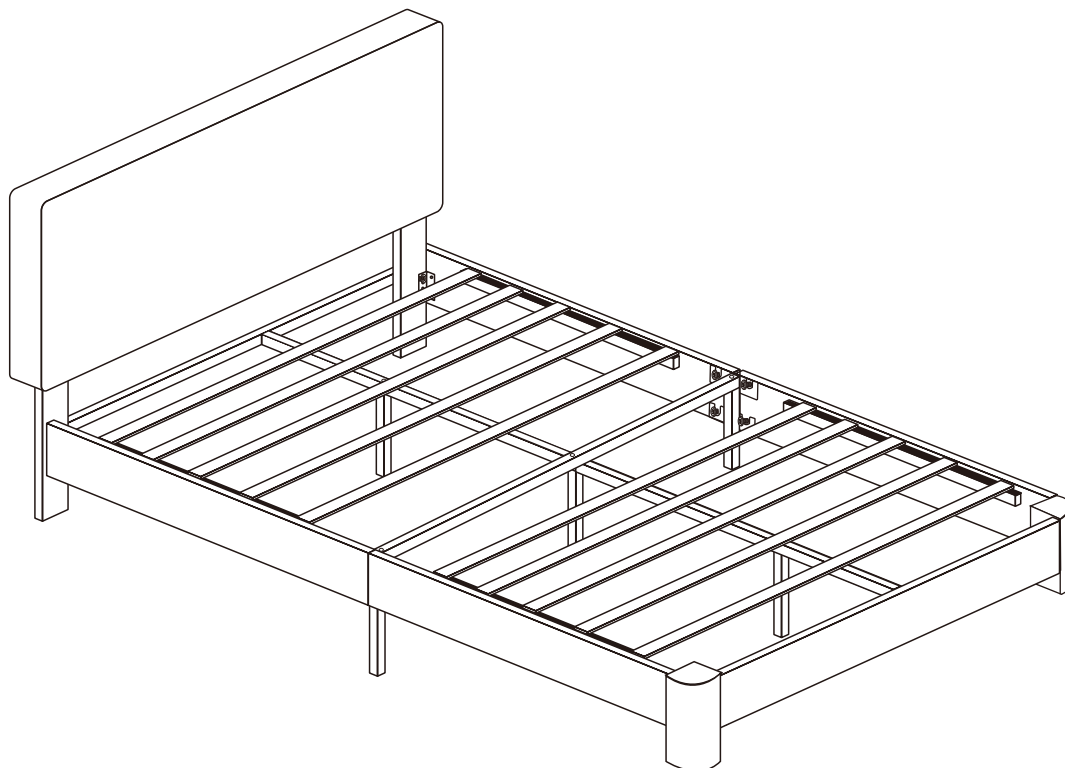
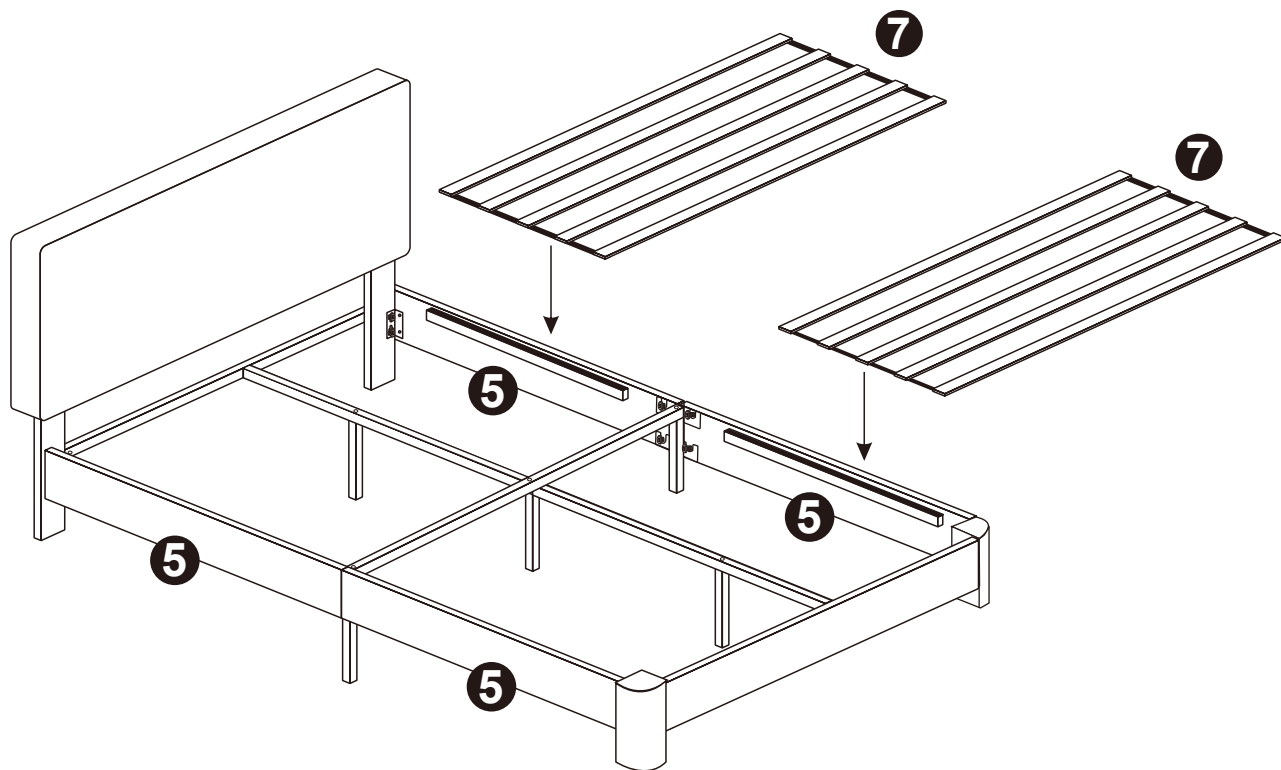

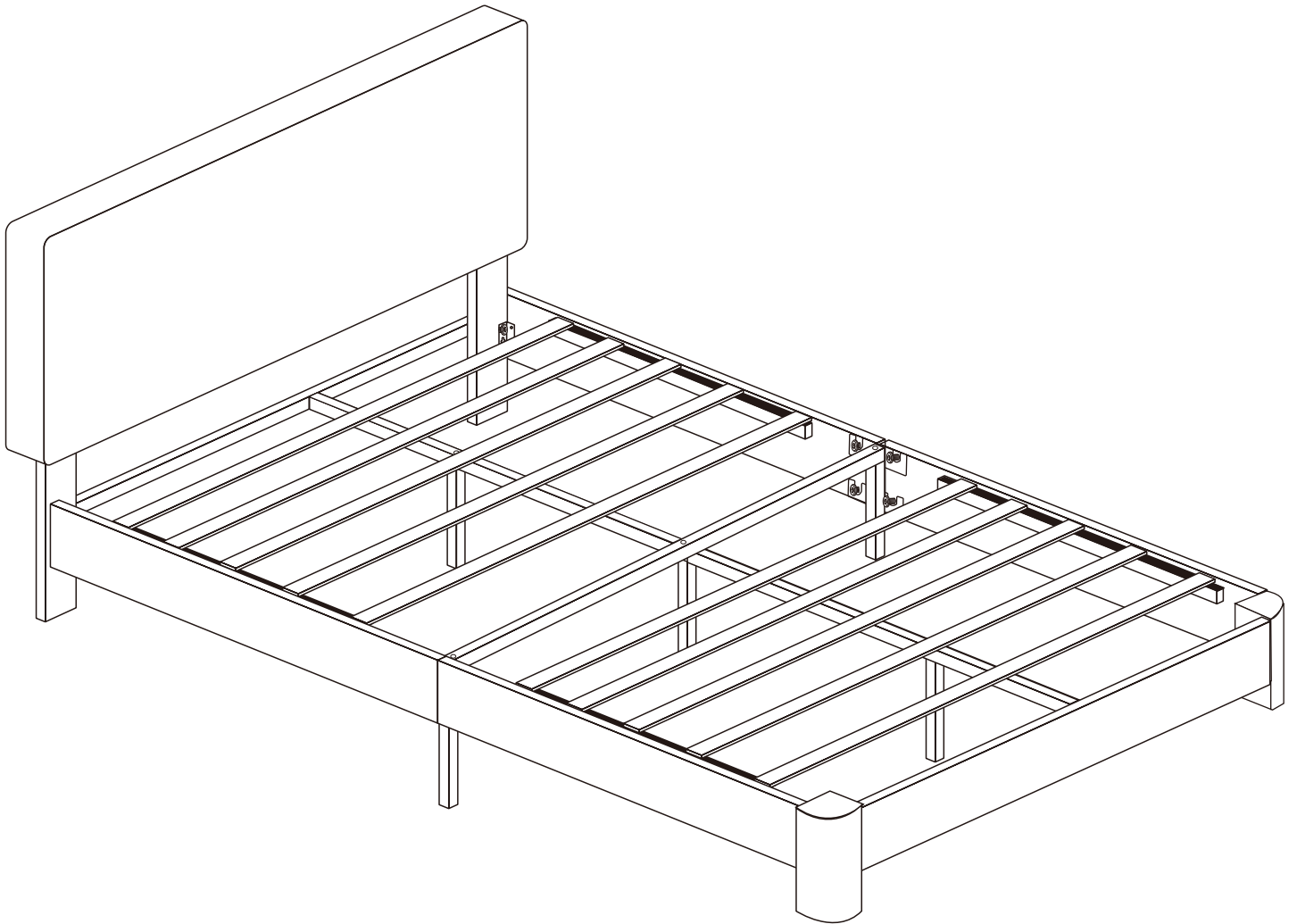

**Job complete!**

In the interest of our environment, please dispose  
of all packaging thoughtfully, thanks!

We' love to hear from you!