

ALMA 60" Cast Iron Wall Mount Kitchen Sink

Cat.No
KSCI60-WH



Length: 60-1/4"
Width: (front of sink to back) 20-3/8"
Height: 18-1/8"
Backsplash to rim: 16"
Front of sink to backsplash: 18-1/2"
Top of rim to top of backsplash: 12-1/2"
Height of apron: 6-1/8"

16" between brackets
48" center to center first bracket to last bracket
3-3/4" from top of sink to bottom of bracket

Interior Dimensions:

Basin Interior: 24-1/8" L X 16-1/8" W
Basin Depth: 8-1/4"
Faucet hole: 1-3/8" Length:

Features:

- ▶ Constructed of cast iron with enamel coating
- ▶ Built-in drain board on each side
- ▶ Faucet centers 8" widespread
- ▶ Can be used with cast iron legs (KCI60-WH-LEGS not included)
- ▶ Mounts to wall
- ▶ Hangers are included
- ▶ Includes tabs that slide into brackets
- ▶ Accommodates 3-1/2" drain
- ▶ Drain board 16-7/8" L X 16" W
- ▶ Rim: 1-3/4"

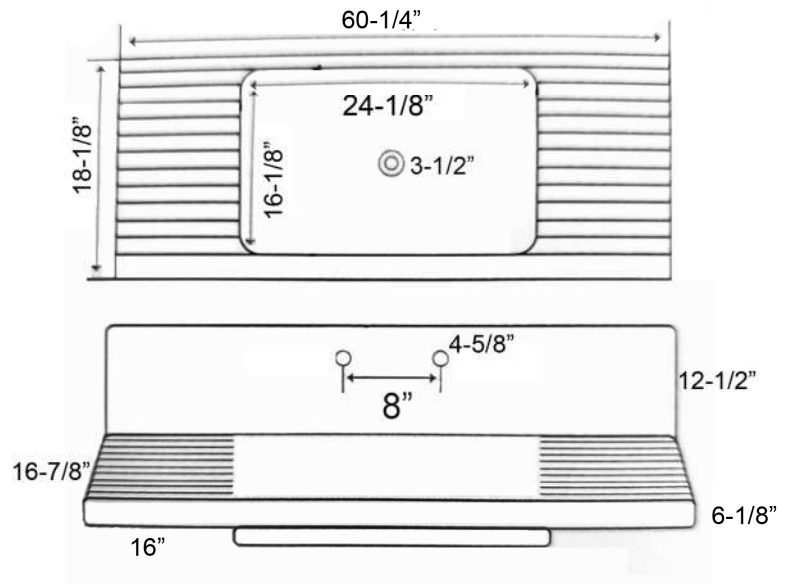

Dimensions of fixture are nominal and may vary within the range of tolerances established.

10/21/2019

P 847•244•1234

www.barclayproducts.com