

# Assembly Instructions

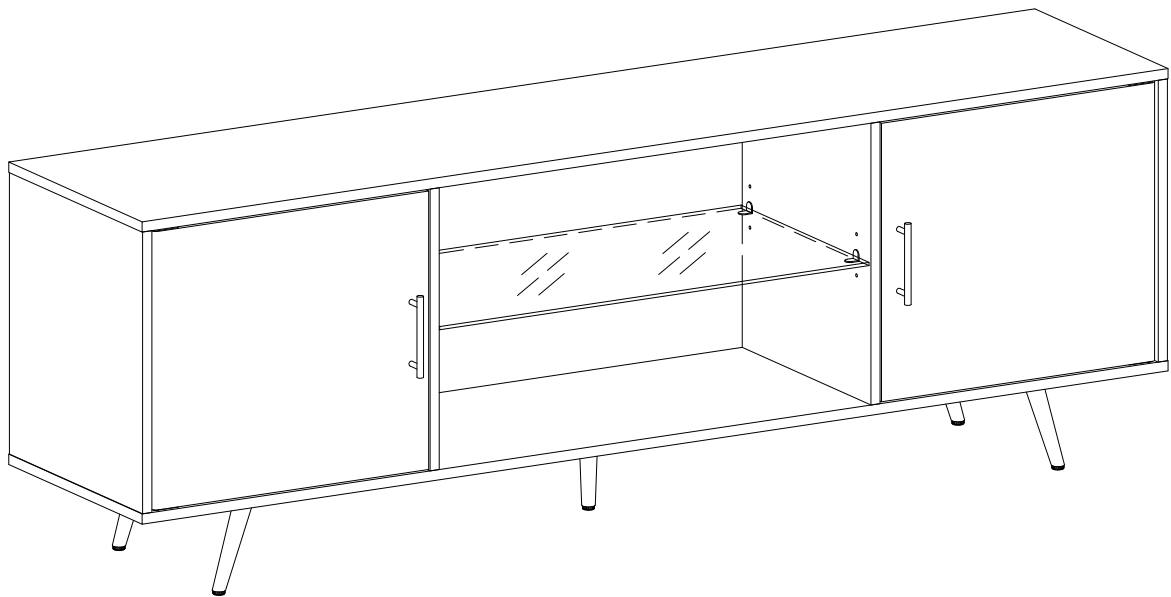

# General Assembly Guidelines

- I. Ensure that all parts and hardware are available before beginning assembly.
- II. Follow each step carefully to ensure the proper assembly of this product.
- III. Two people are recommended for ease in the assembly of this product.
- IV. The three main types of hardware used to assemble this product are : wood dowels , screws and bolts.
- V. The provided glue is to secure wood dowels in place . When first inserting dowels , locate the appropriate hole for the dowel , place a small amount of glue in the hole and insert the dowel . Wipe away excess glue immediately.

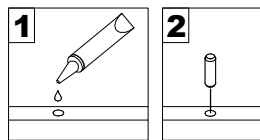

In future assembly steps when dowels are necessary to attach assembly parts together , place a small amount of glue on the end of the dowel before attaching parts together . Wipe away excess glue immediately.

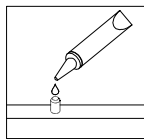

- VI. A Phillips head screwdriver is required for the assembly of this product .

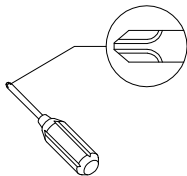



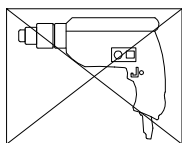



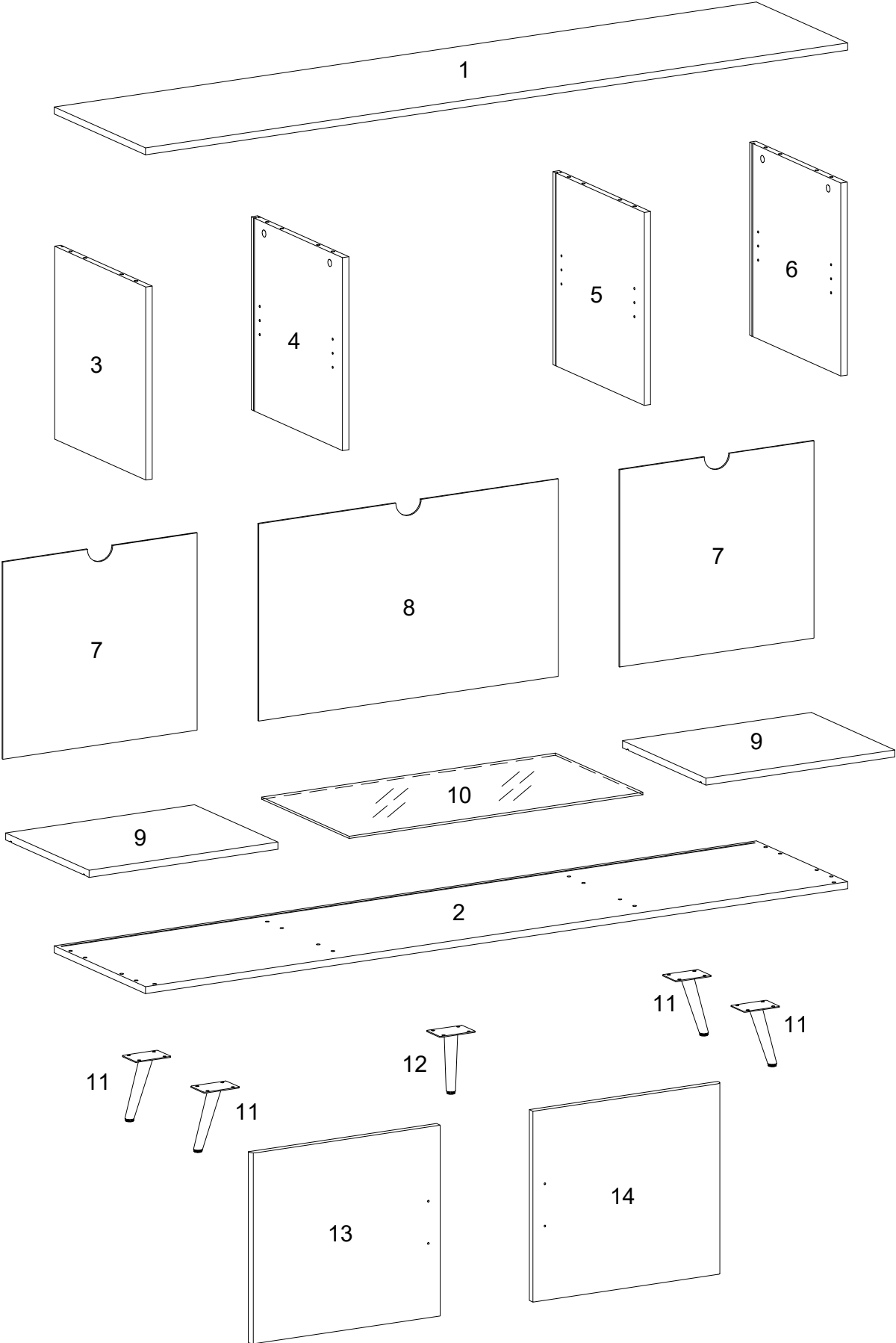



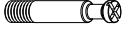









- VII. Power tools should not be used to assemble this product .



# Parts List



# Hardware List

A		Ø8x30mm	Wooden dowel	16 pcs
B		Ø6x35mm	Cam bolt	8 pcs
C		Ø15x11mm	Cam lock	8 pcs
D		Ø30mm	Sticker	8 pcs
E		Ø6x50mm	Bolt	8 pcs
F		Ø6x12mm	Bolt	20 pcs
G		M 4	Hex Key	1 pcs
H		Ø8x5x16mm	Shelf support pin	8 pcs
J			Glass holder	4 pcs
K			Door stopper	2 pcs
L		Ø3x15mm	Screw	4 pcs
M			Door Hinge	2 pcs
N			Door Hinge	2 pcs
P			Plastic pivot	4 pcs
Q		Ø3x12mm	Screw	8 pcs
R			Bolt	2 pcs
S			Handle	2 pcs
T		Ø4x22mm	Handle Bolt	4 pcs
U		Ø3x17mm	Screw	12 pcs
V			Plastic wedge	12 pcs
W			Glue tube	1 pcs

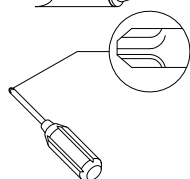

Philips head screwdriver required for assembly  
(not included)

*The hardware quantities listed above are required for proper assembly.  
Some extra hardware may also have been included.*

# Step 1

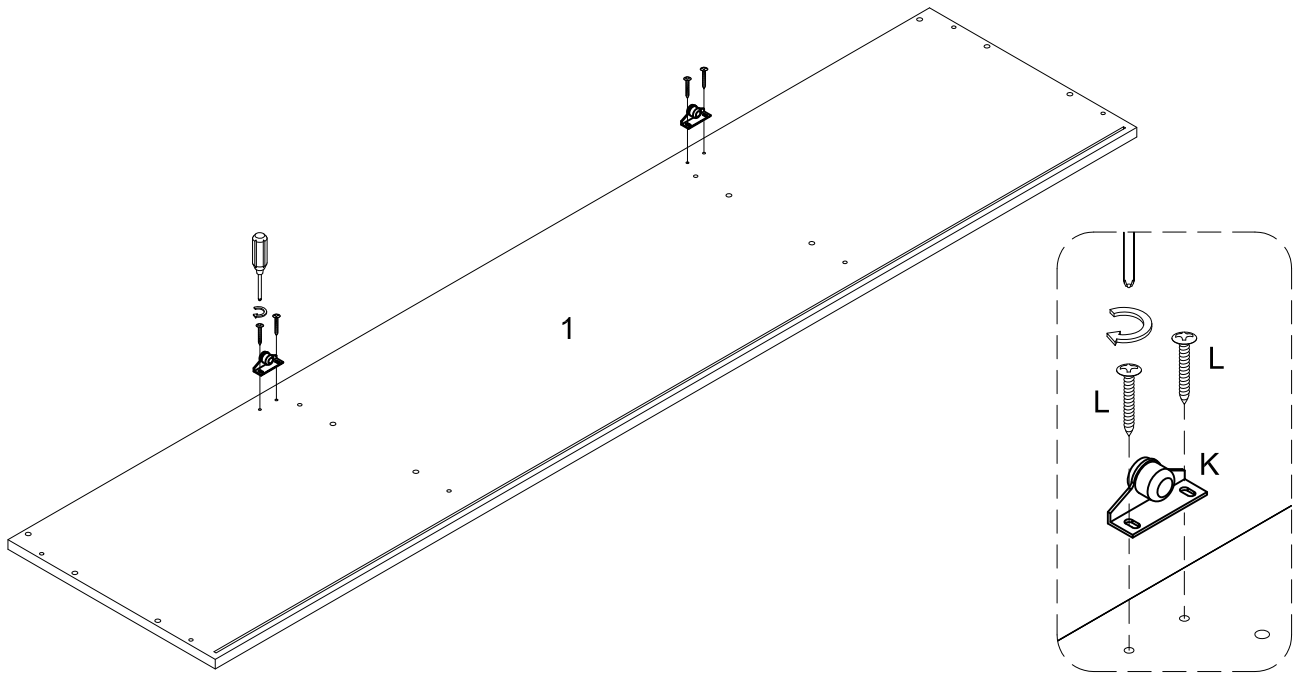

Attach door stopper (K) to part (1) using screw (L) with screwdrivers.

# Step 2

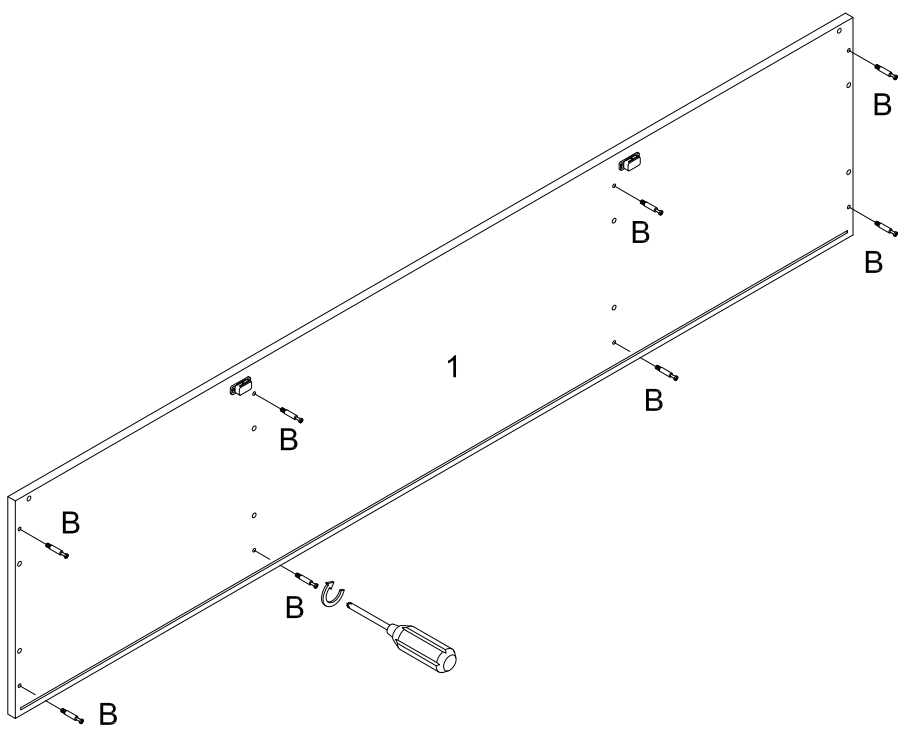

Attach cam bolt (B) to part (1) with screwdriver.

## Step 3

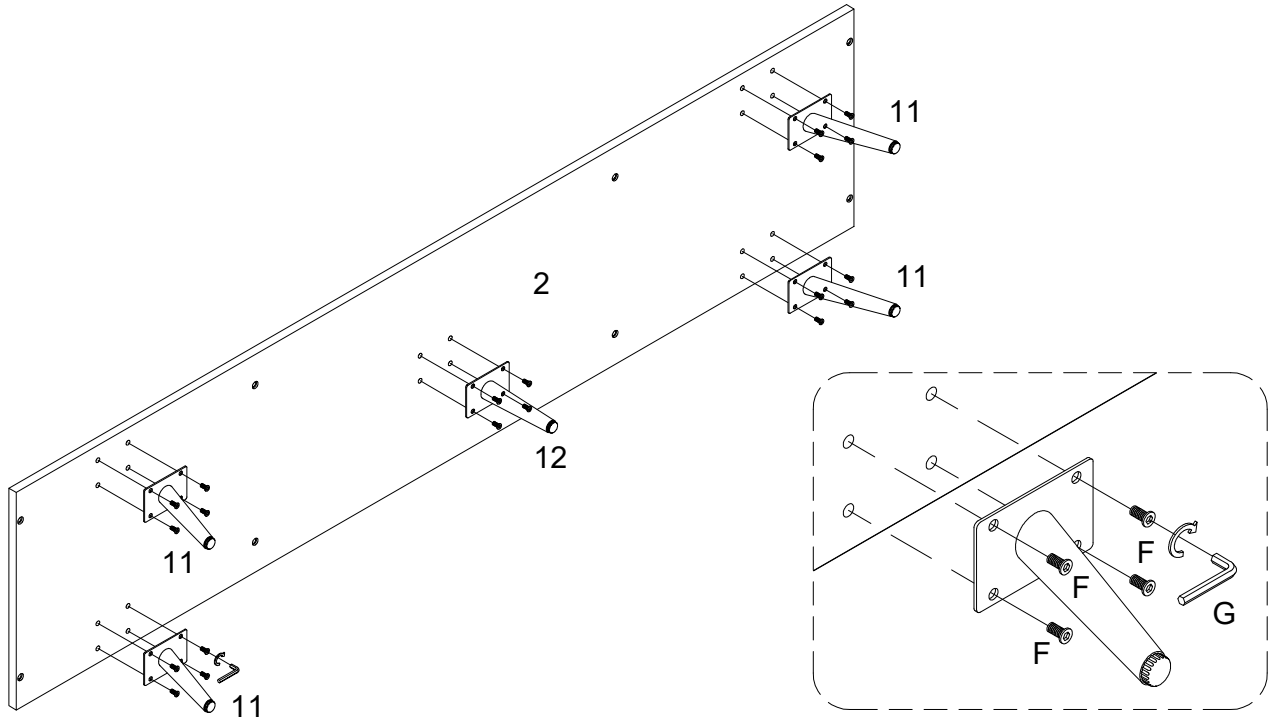

Use hex key(G) to secure bolt (F) into part (2).

## Step 4

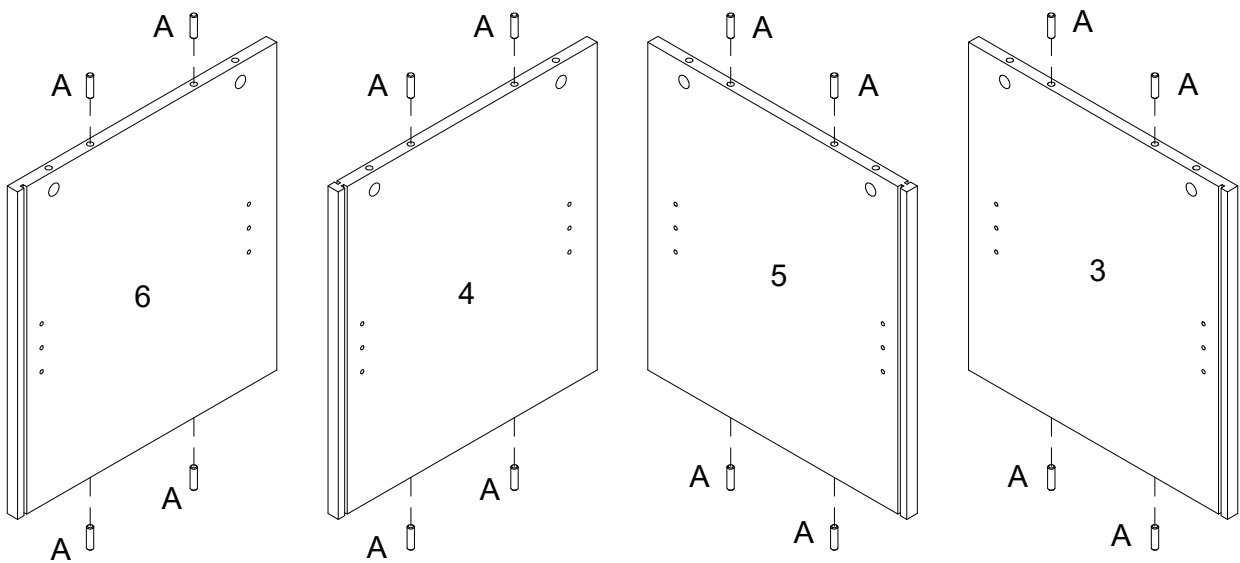

Insert wooden dowel (A) into part (3,4,5,6).

## Step 5

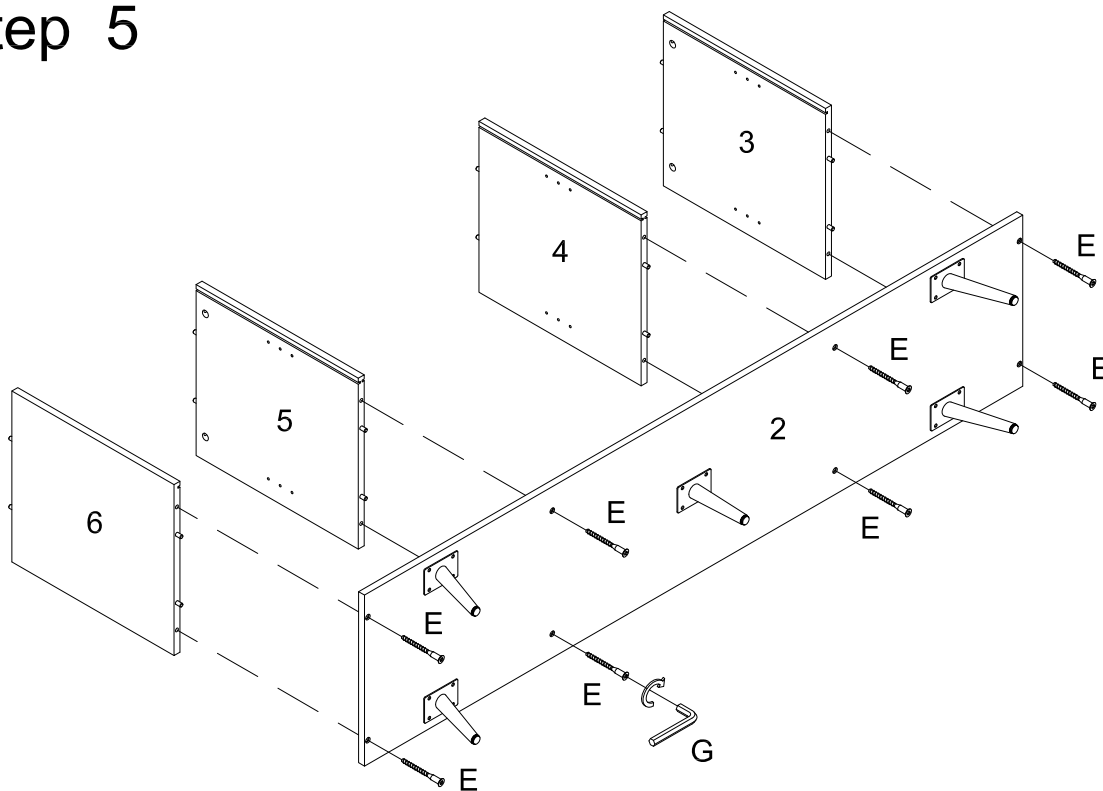

Attach part (3,4,5,6) to part (2) using bolt (E) with hex key (G)

## Step 6

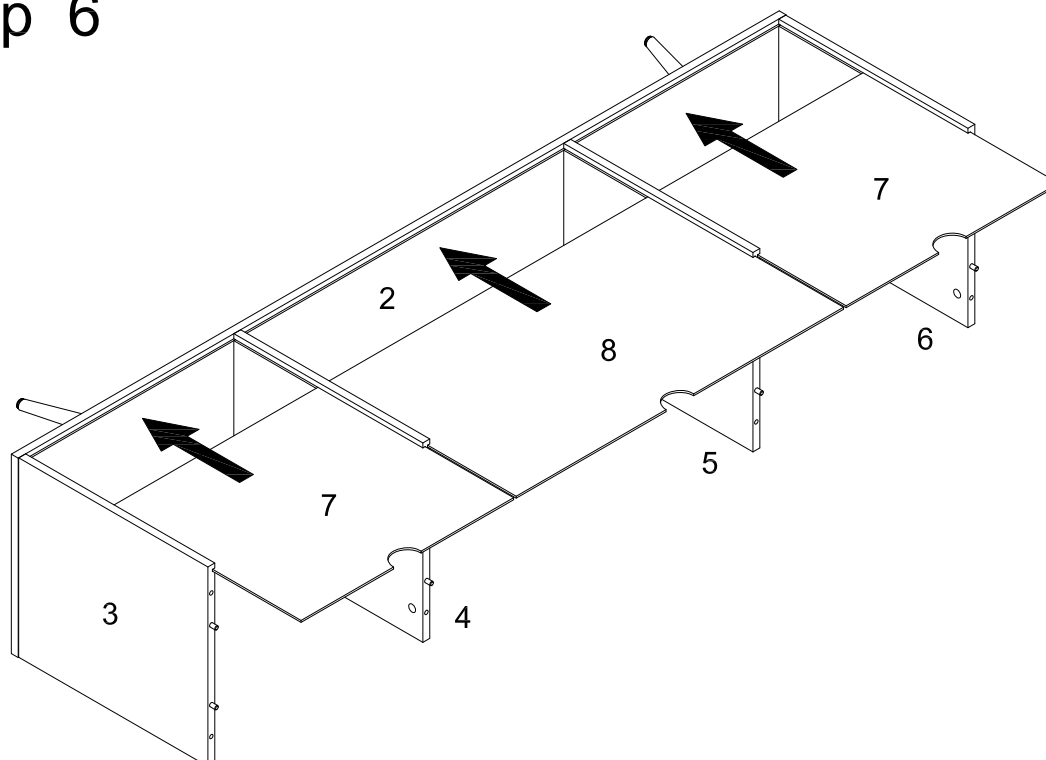

Slide back panel (7,8) into grooves as per diagram.

## Step 7

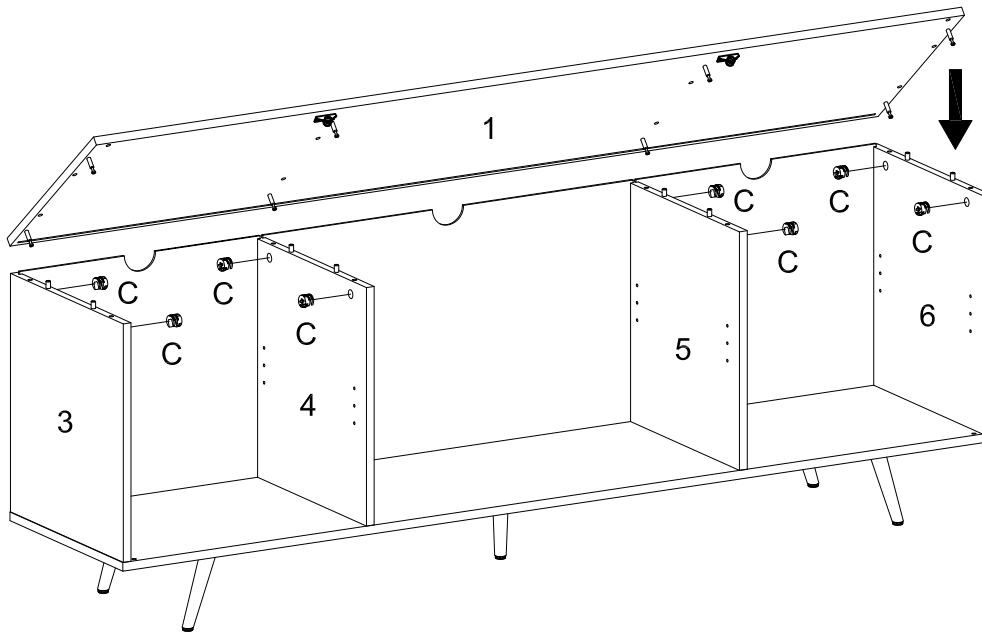
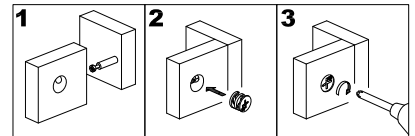

Attach part (1) to part (3,4,5,6), then insert and secure cam lock (C) to part (3,4,5,6) to lock it

## Step 8

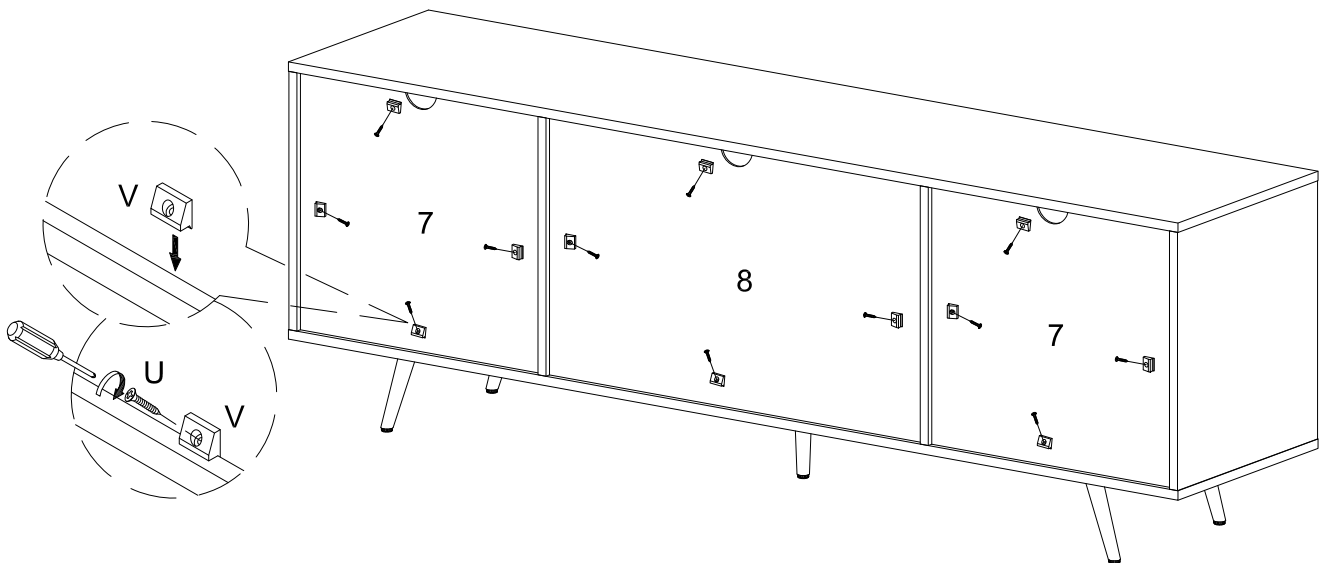

Attach plastic wedge (V) to part (7,8) using screw (U) with screwdriver.

## Step 9

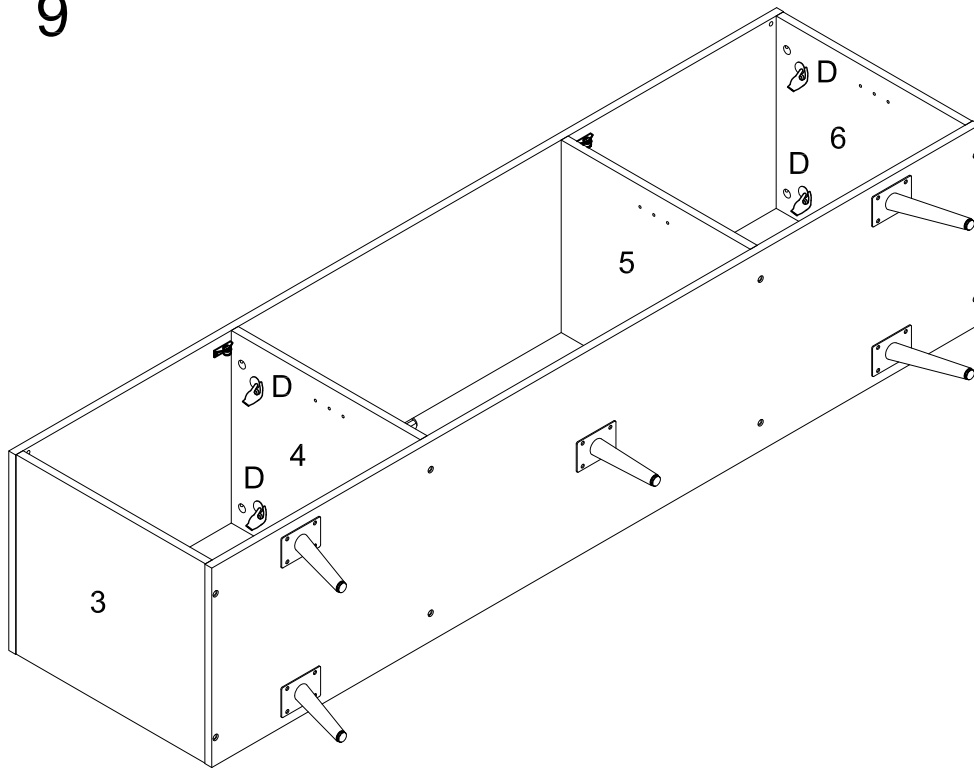

Place sticker (D) over holes as per diagram.

## Step 10

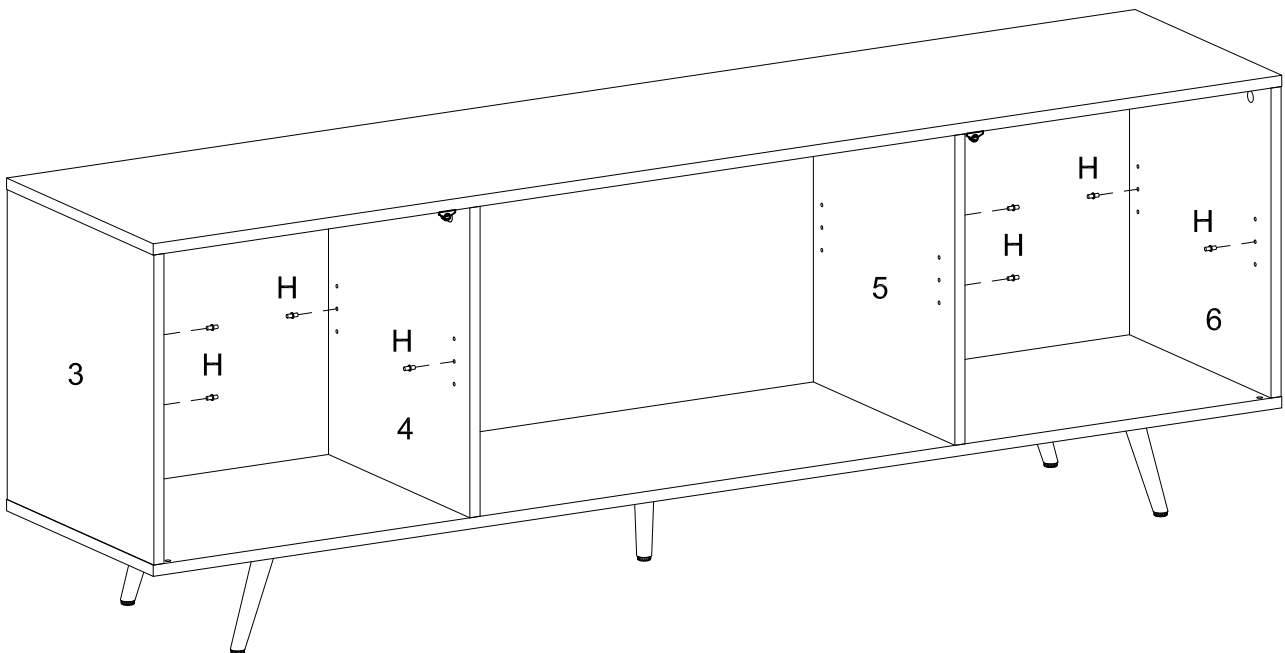

Insert shelf support pin (H) into part(3,4,5,6).

## Step 11

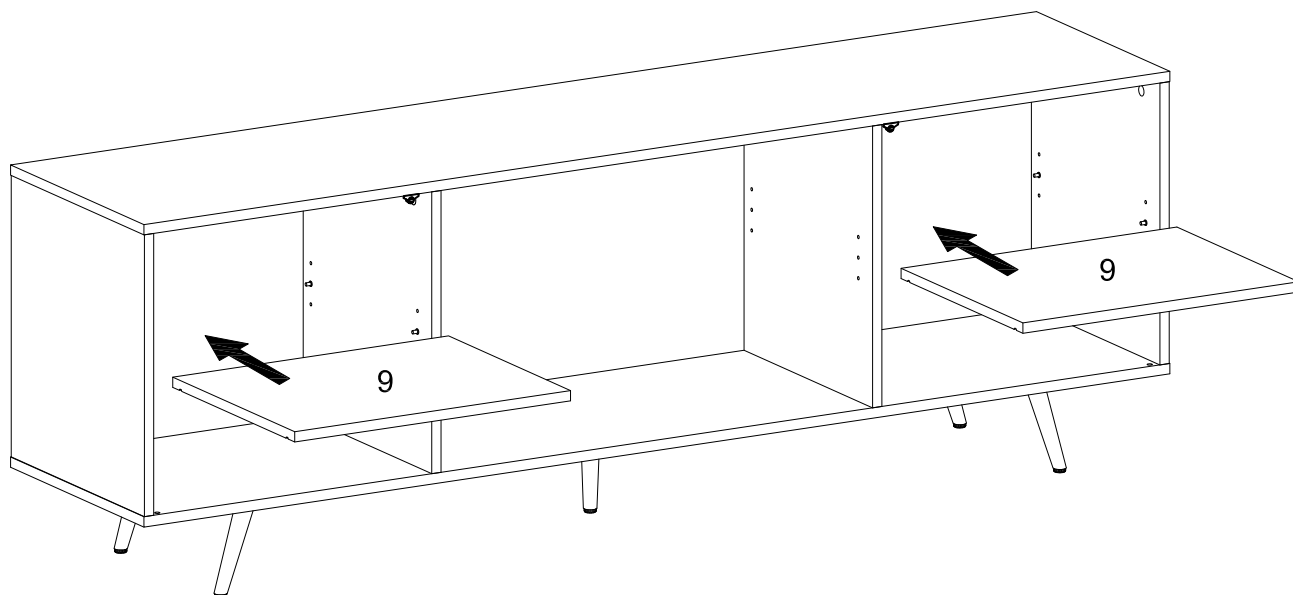

Place shelf (9) on top of support pin .

## Step 12

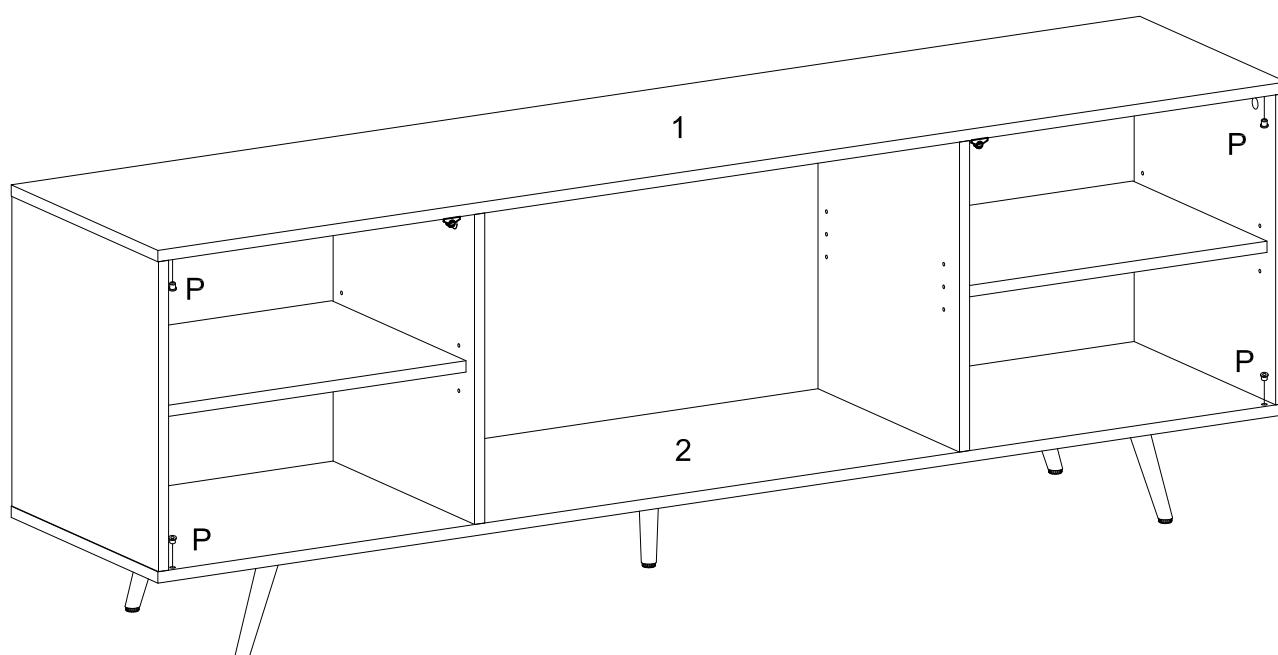

Place plastic pivot (P) over holes as per diagram.

## Step 13

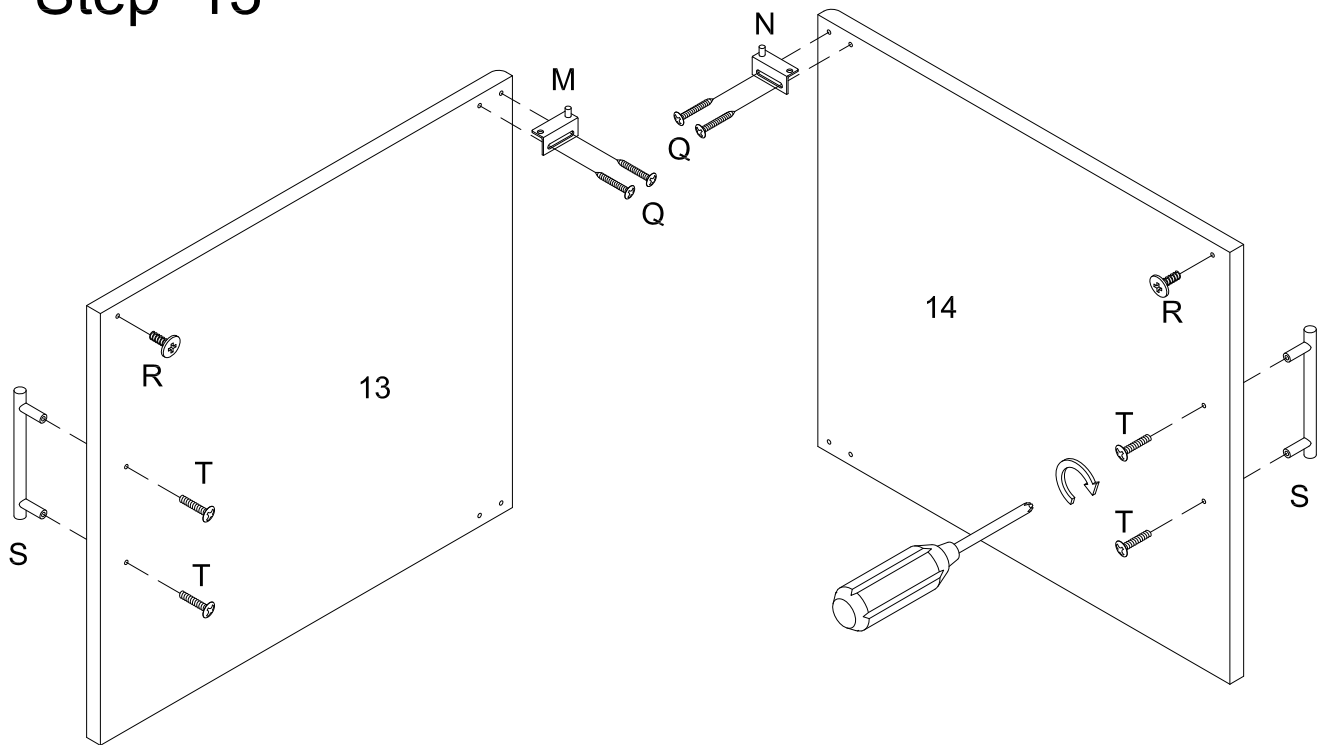

Attach handle (S) to part (13,14) using handle bolt (T) with screwdriver. Attach door hinge (M,N) to part (13,14) using screw (Q) with screwdriver. Attach bolt (R) to part (13,14) with screwdriver.

## Step 14

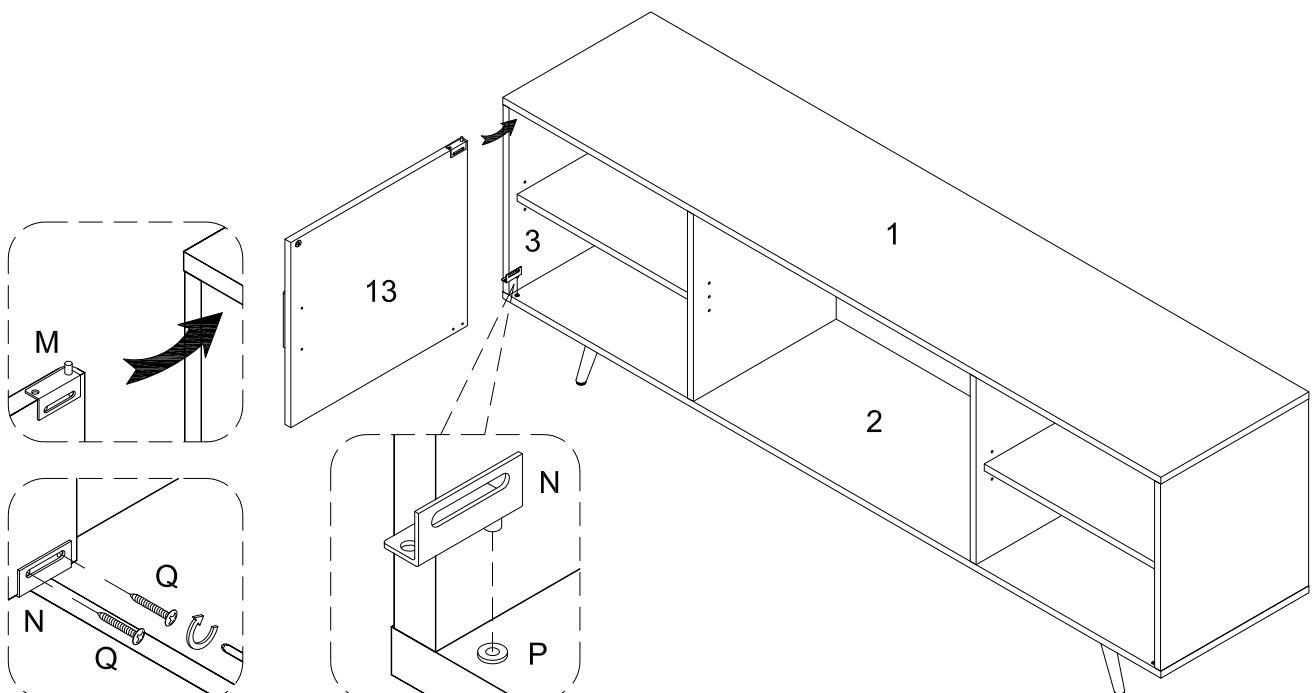

Insert top door hinge (M) into plastic pivot (P) on part (1), then slide the door (13) into bottom hinge (N). Secure door by tightening door hinge (N) using screws (Q) with equal pressure.

## Step 15

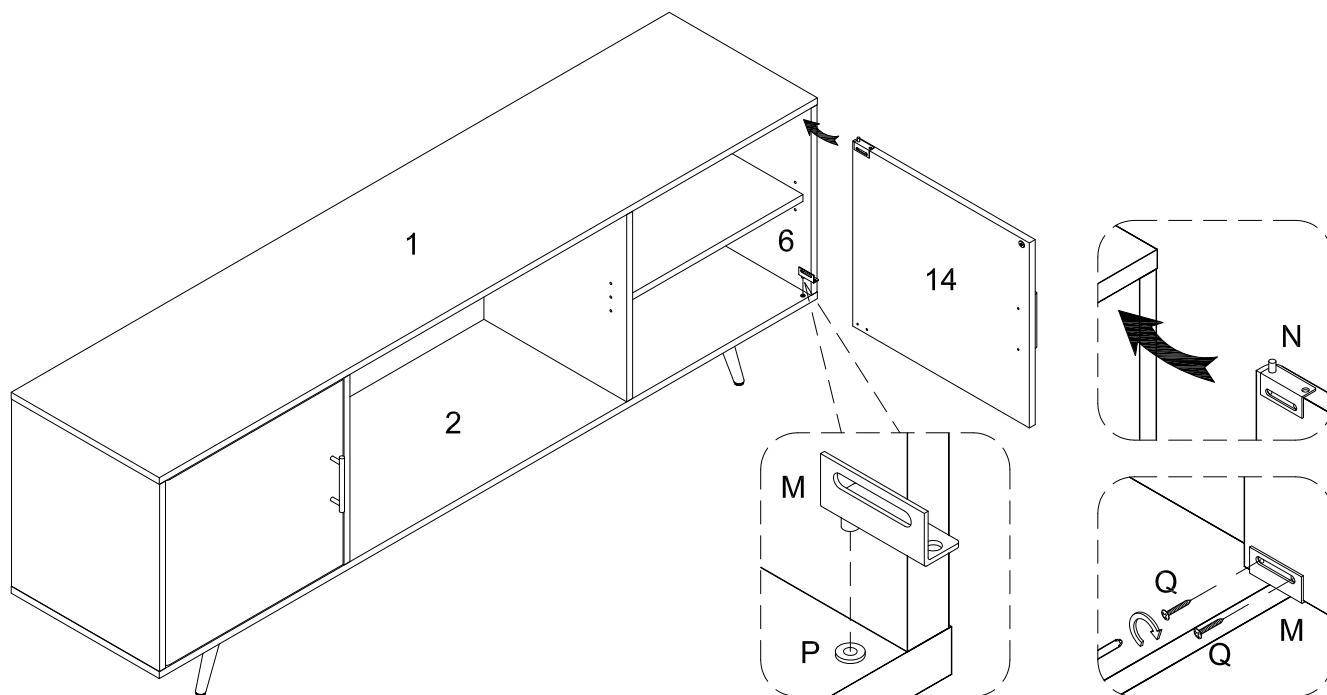

Insert top door hinge(N) into plastic pivot (P) on part (1), then slide the door (14) into the bottom hinge (M). Secure door by tightening door hinge (M) using screws (Q) with equal pressure.

## Step 16

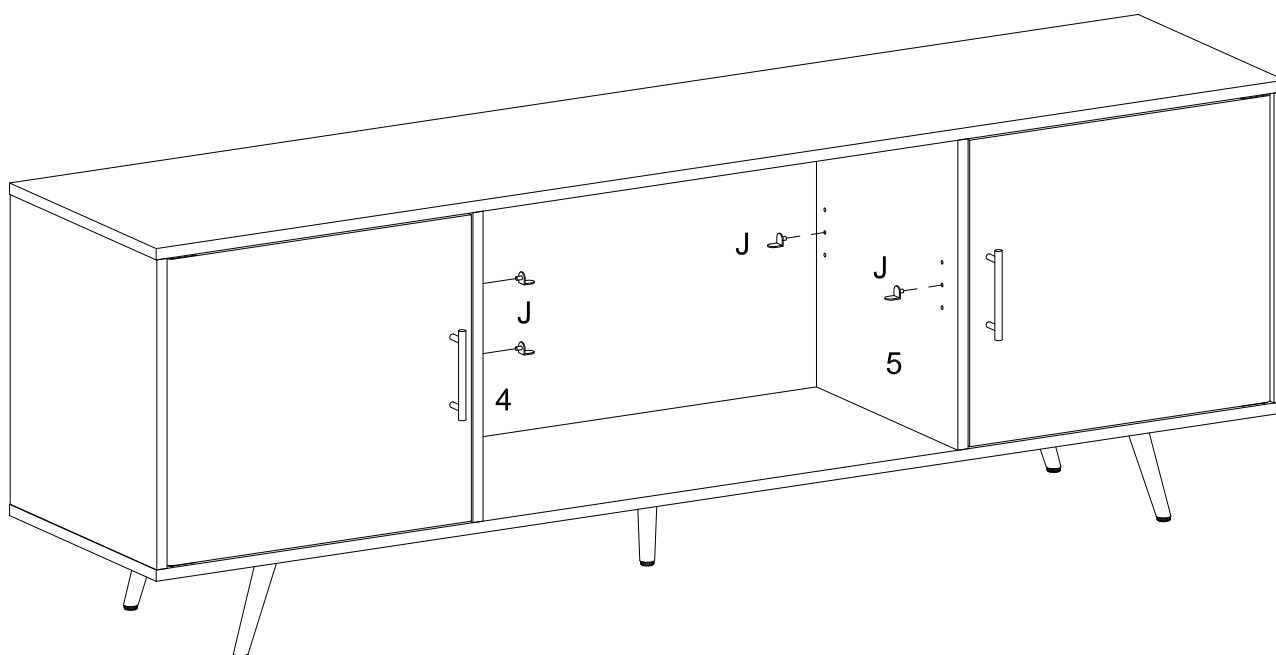

Insert glass holder (J) into part(4,5).

## Step 17

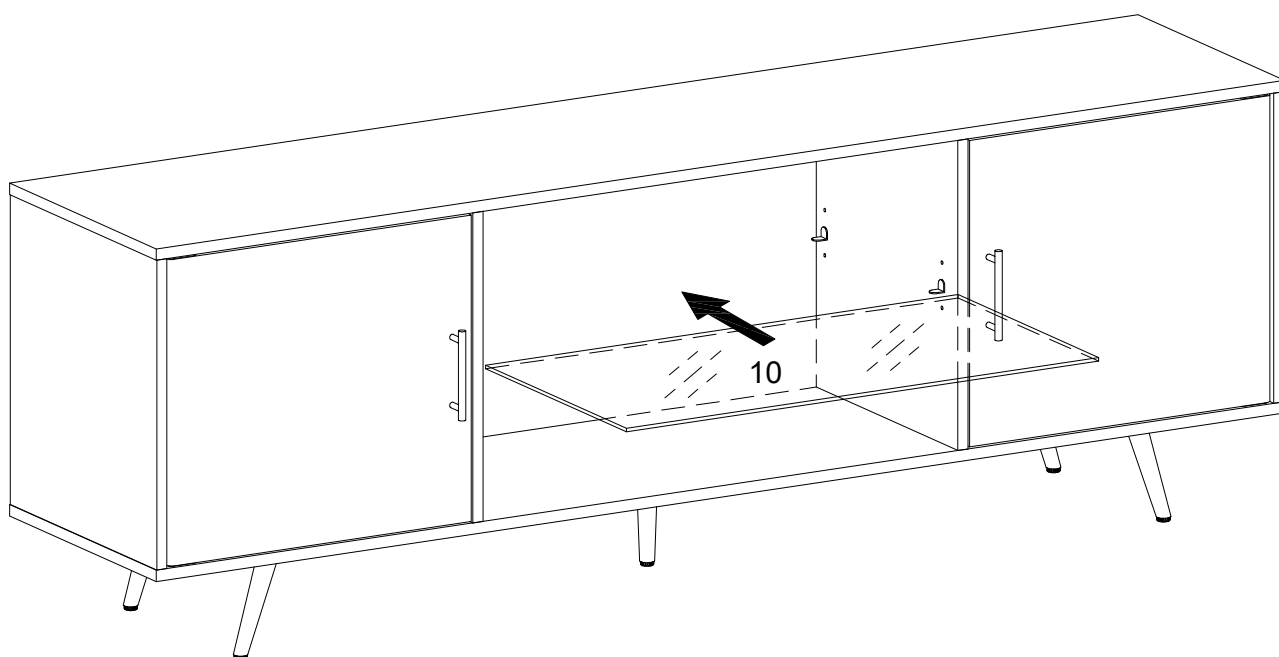

Place glass shelf (10) on top of glass holder carefully.

## Step 18

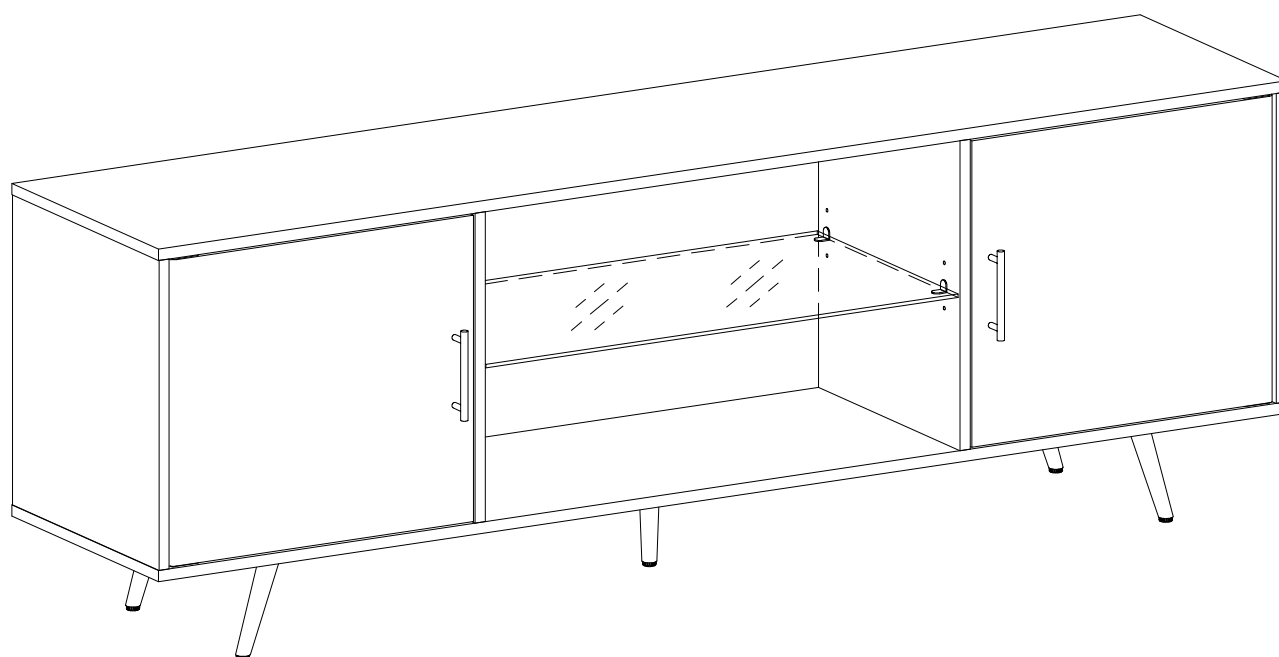

Final Assembly