

ASSEMBLY INSTRUCTIONS

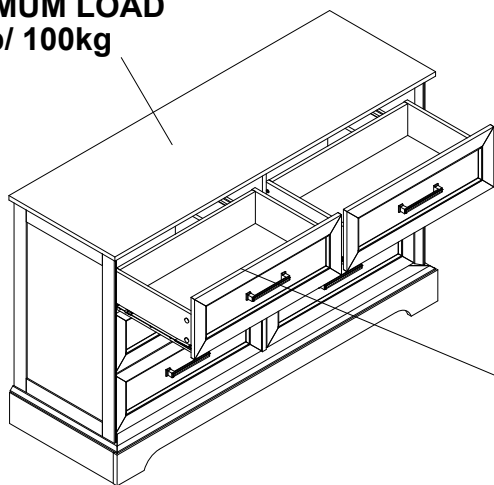

WARNING !

MAXIMUM LOAD
220 lb/ 100kg

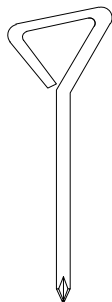

Estimated Time for Assembly

60 mins

MAXIMUM LOAD
20 lb/ 9.1kg

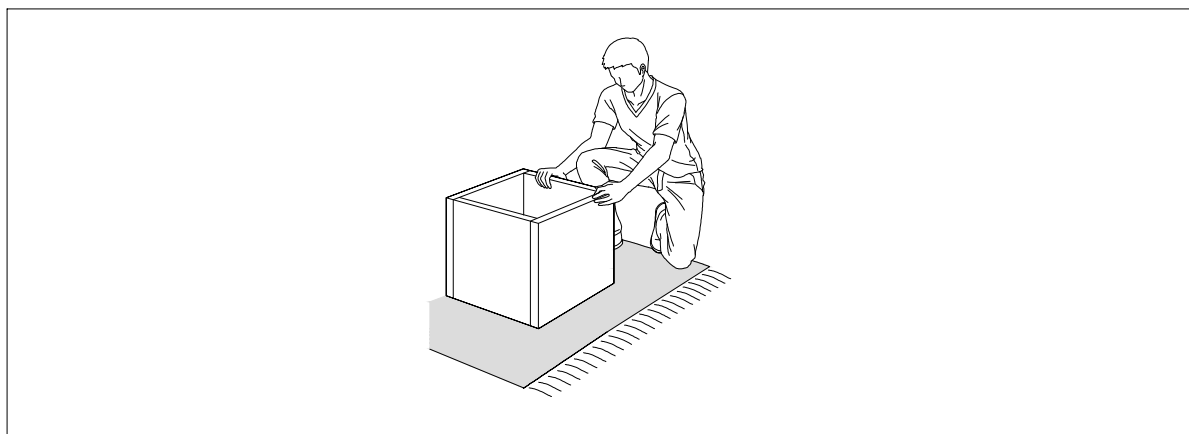

Assemble the furniture on empty carton, carpet, or rug to prevent scratches or damage.

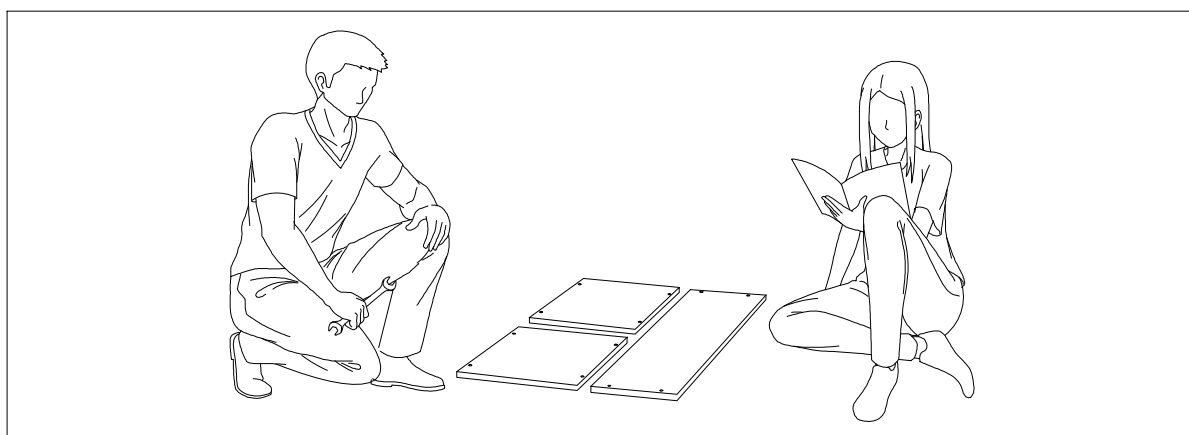

This furniture requires 2 people to assembly.

Make sure no parts are missing or damaged before assembly.

Board Identification

Not actual size

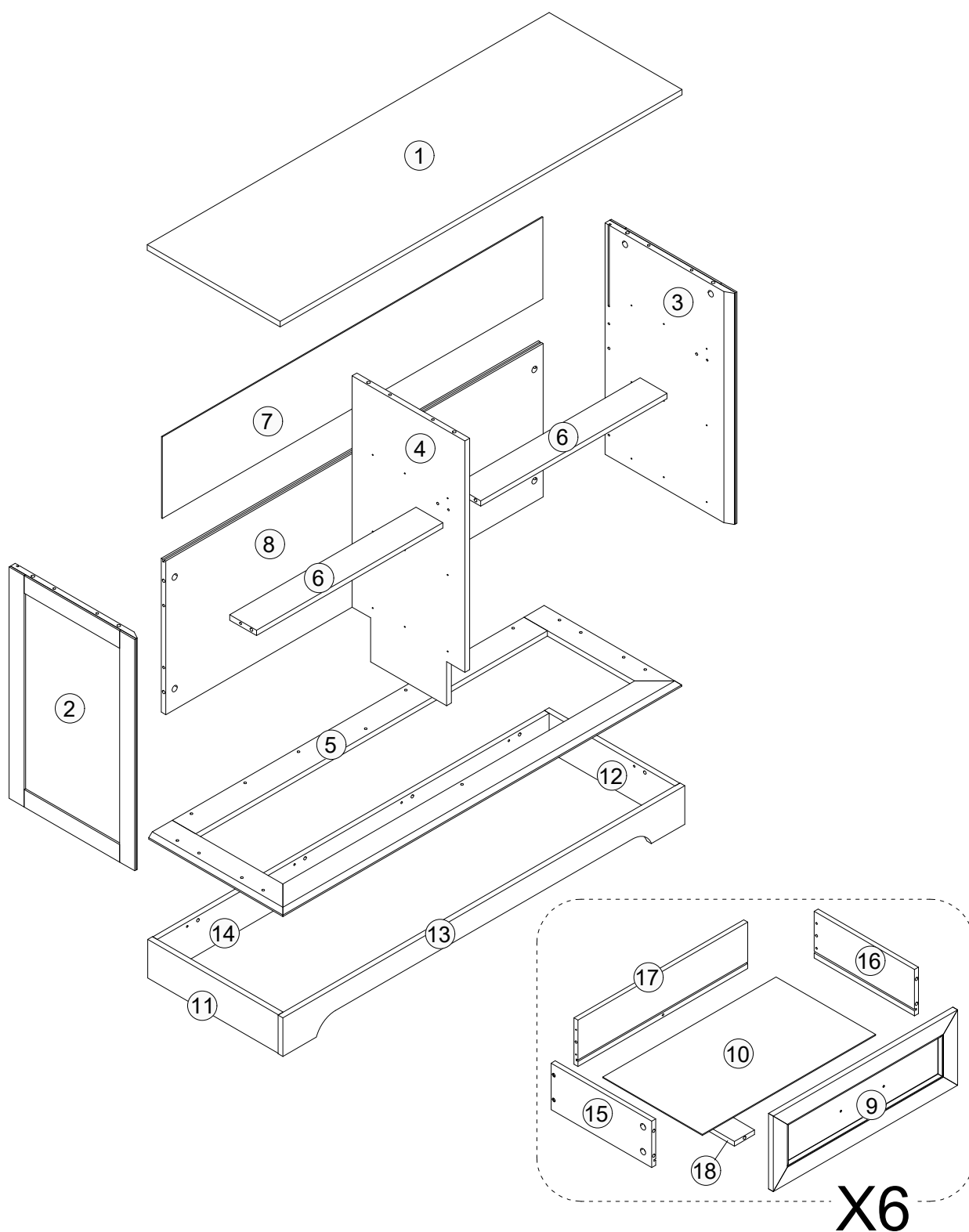

BOARD IDENTIFICATION

Not actual size

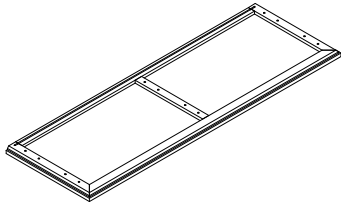

① x1

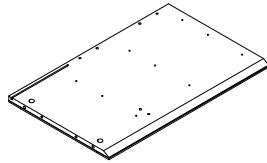

② x1

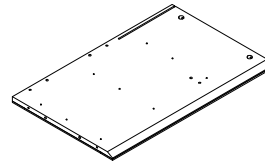

③ x1

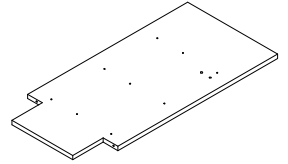

④ x1

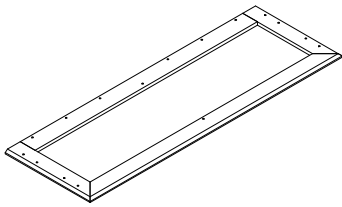

⑤ x1

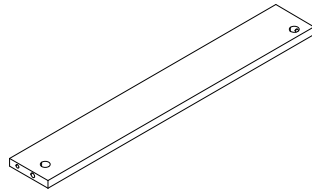

⑥ x2

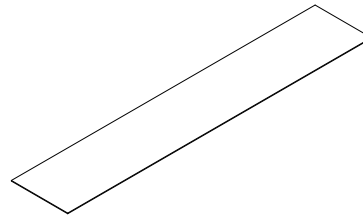

⑦ x1

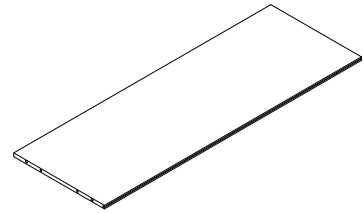

⑧ x1

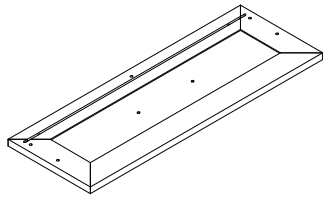

⑨ x6

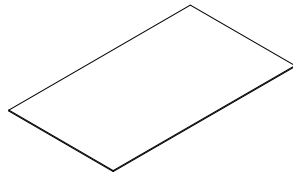

⑩ x6

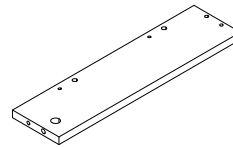

⑪ x1

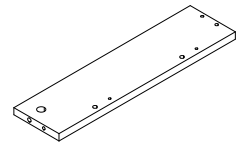

⑫ x1

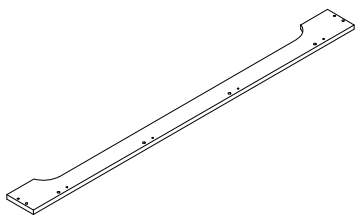

⑬ x1

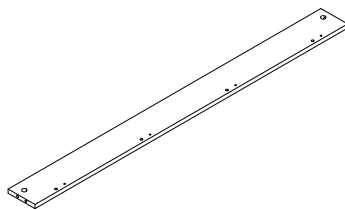

⑭ x1

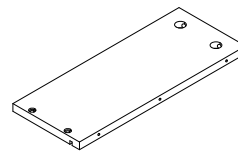

⑮ x6

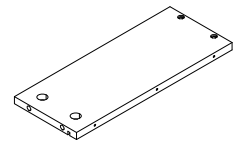

⑯ x6

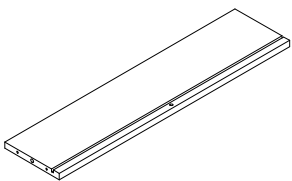

⑰ x6

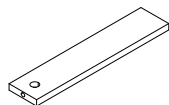

⑱ x6

HARDWARE LIST

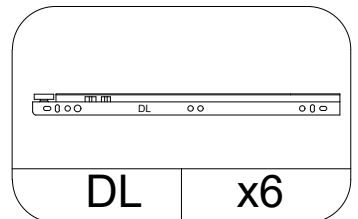
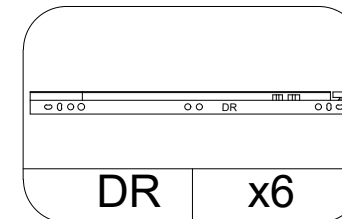
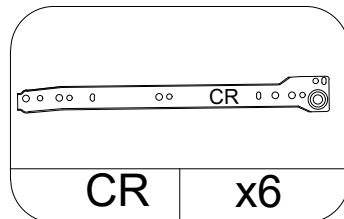
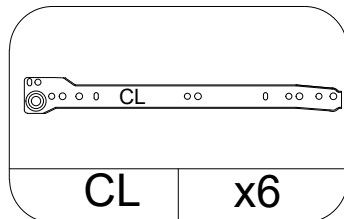
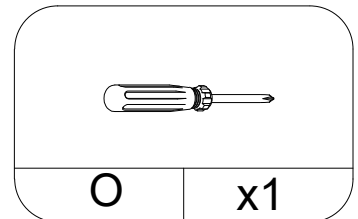
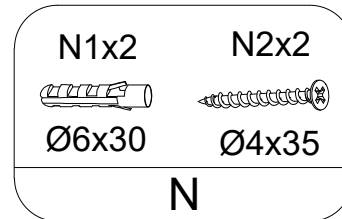
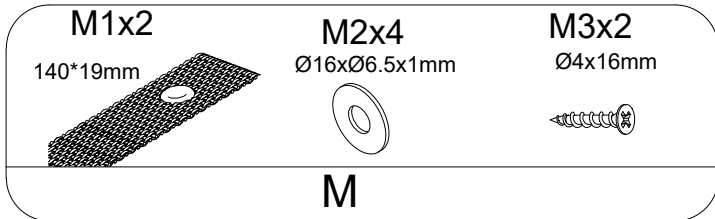
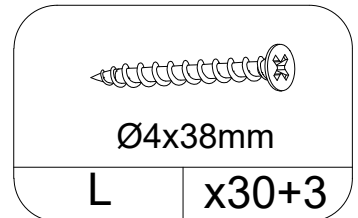
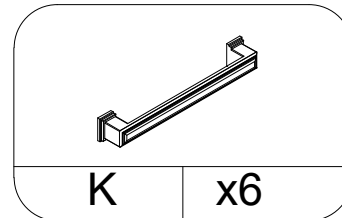
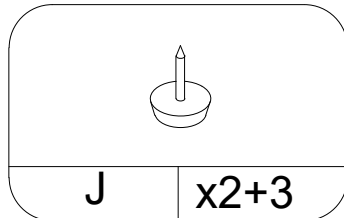
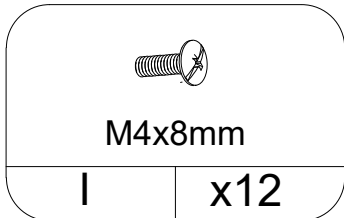
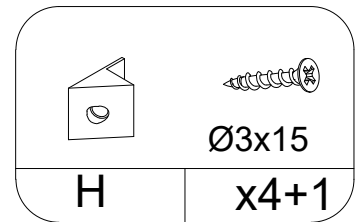
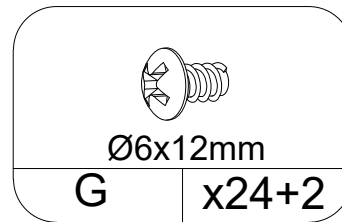
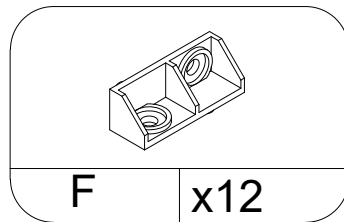
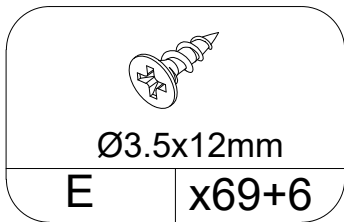
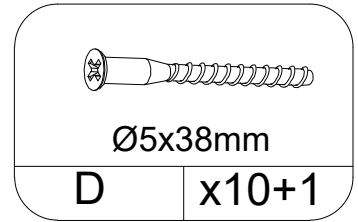
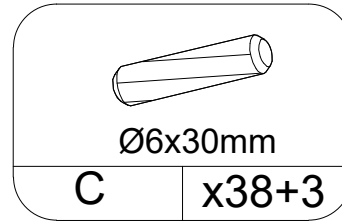
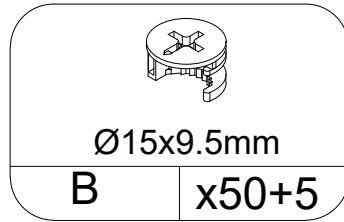
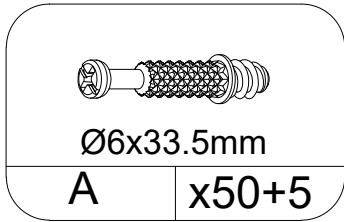

Cam Lock Fastening System

Insert the cam bolt into the hole first, then insert the cam lock and lock it.

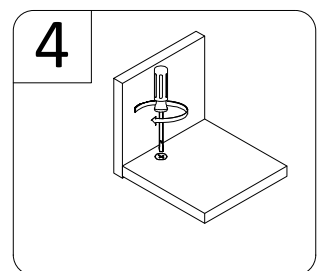
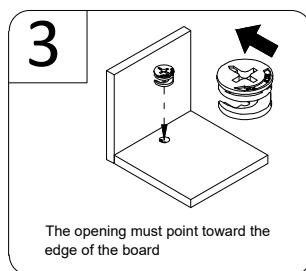
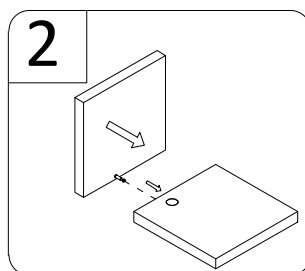
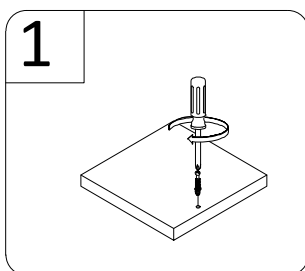

STEP 1

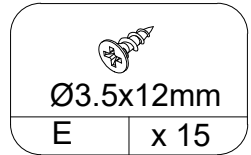
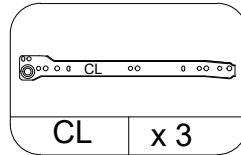
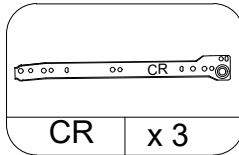
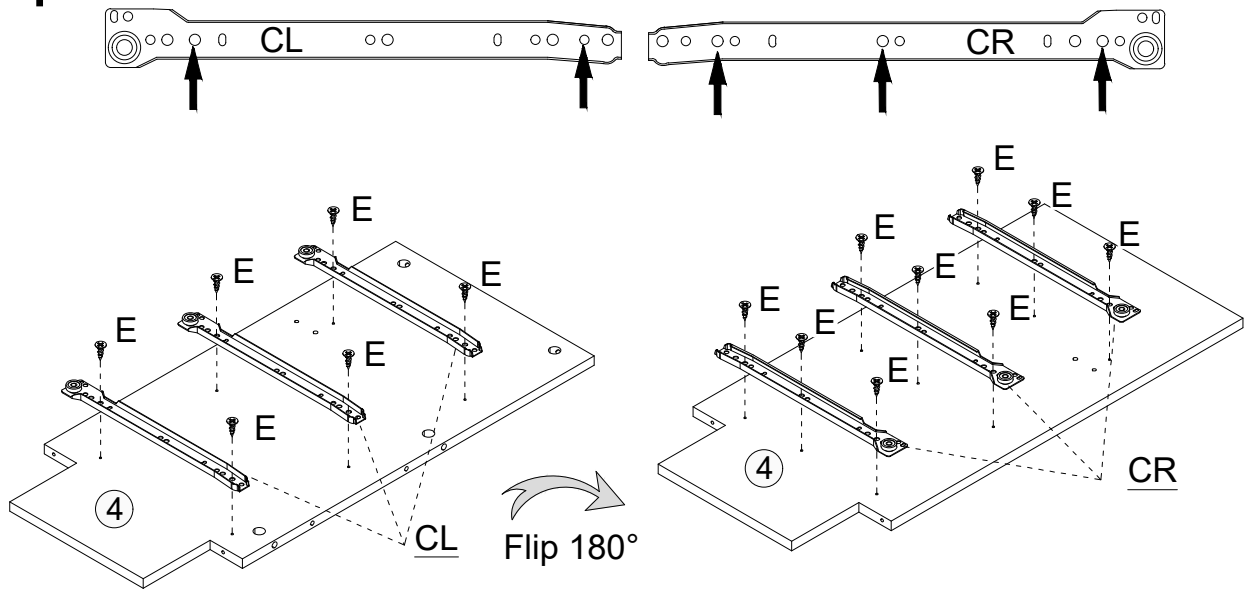

STEP 2

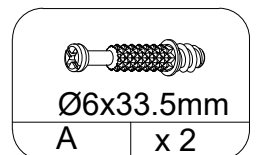
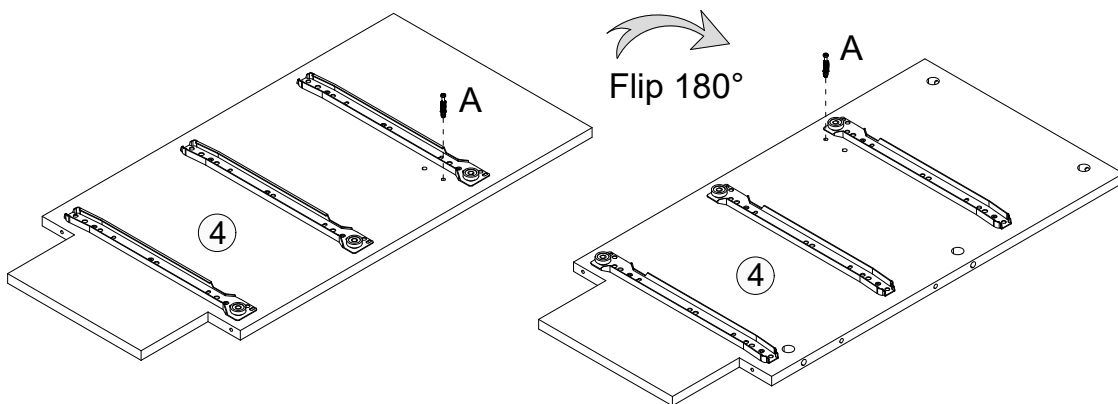
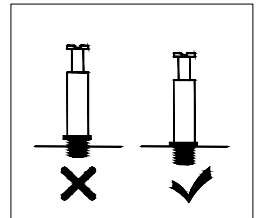

STEP 3

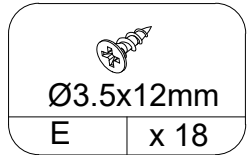
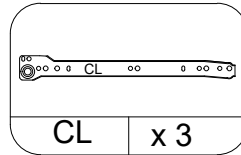
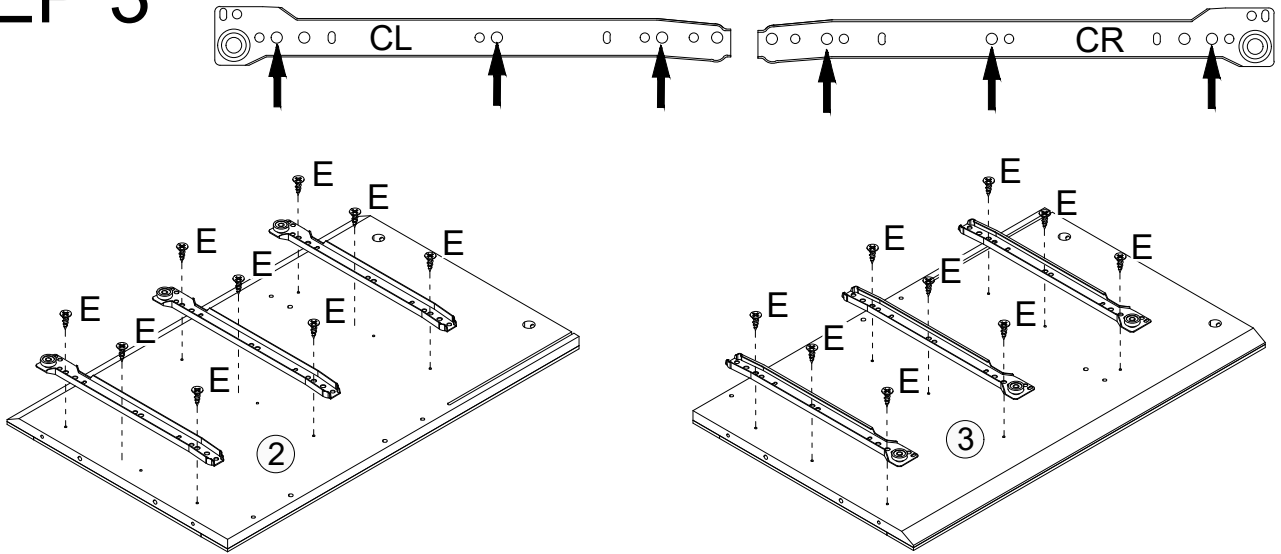

STEP 4

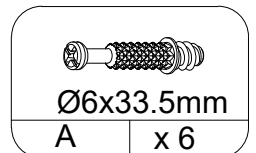
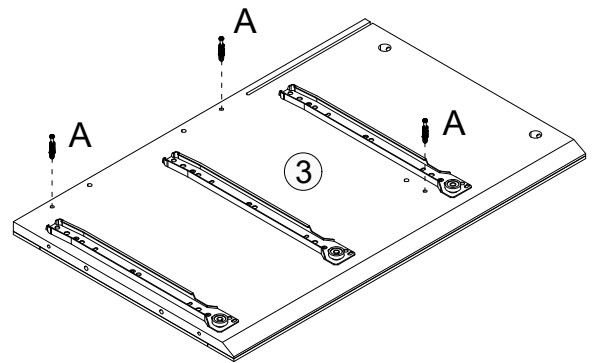
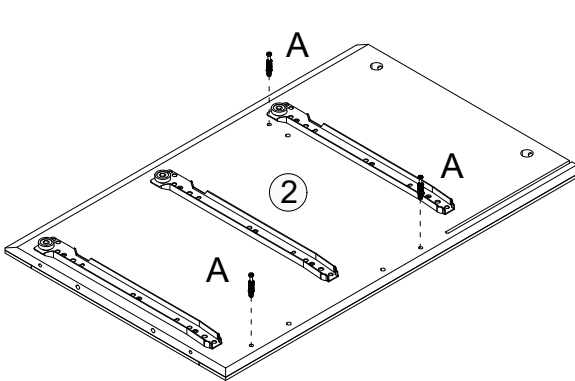
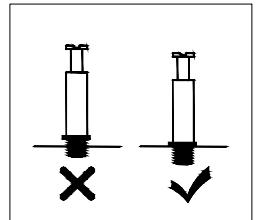

STEP 5

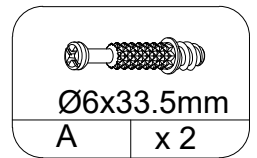
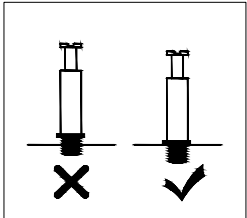
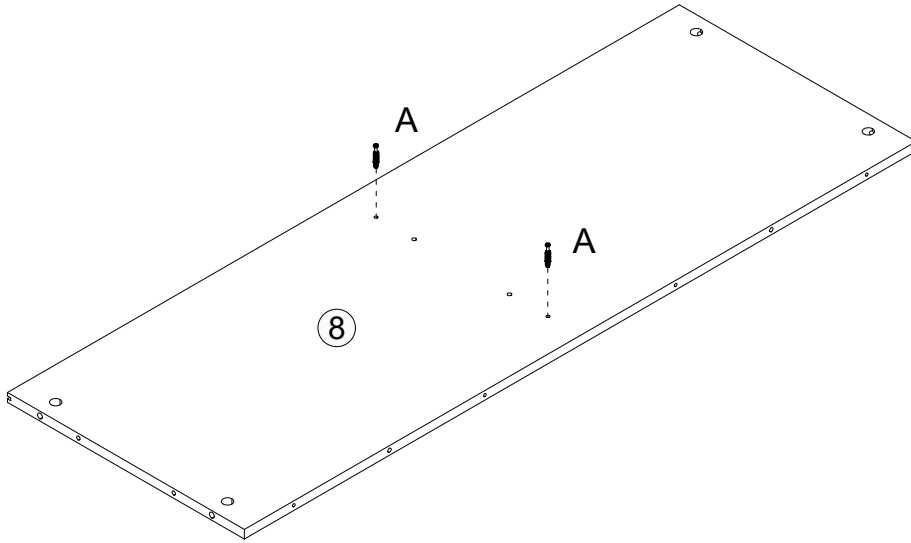

STEP 6

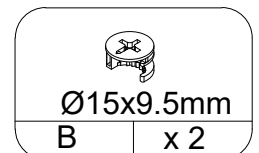
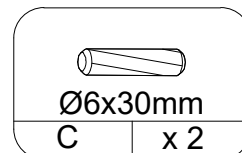
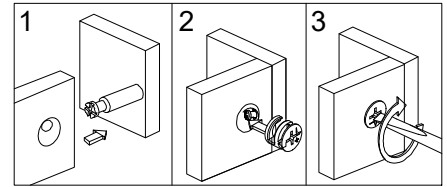
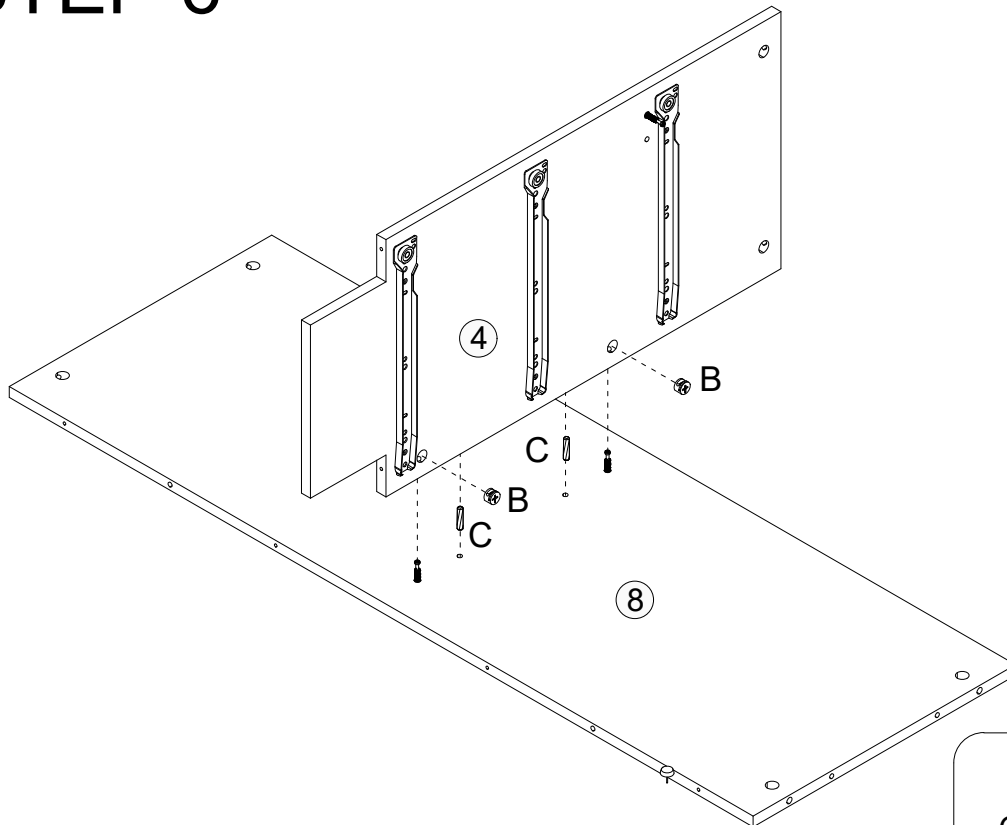

STEP 7

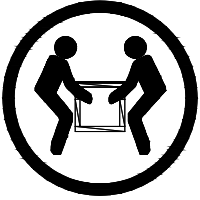

CAUTION: Heavy! You may need assistance with this step

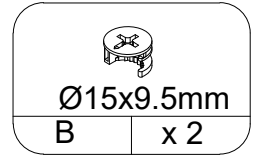
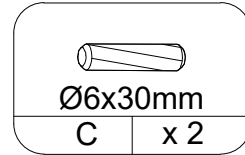
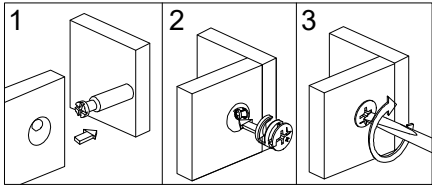
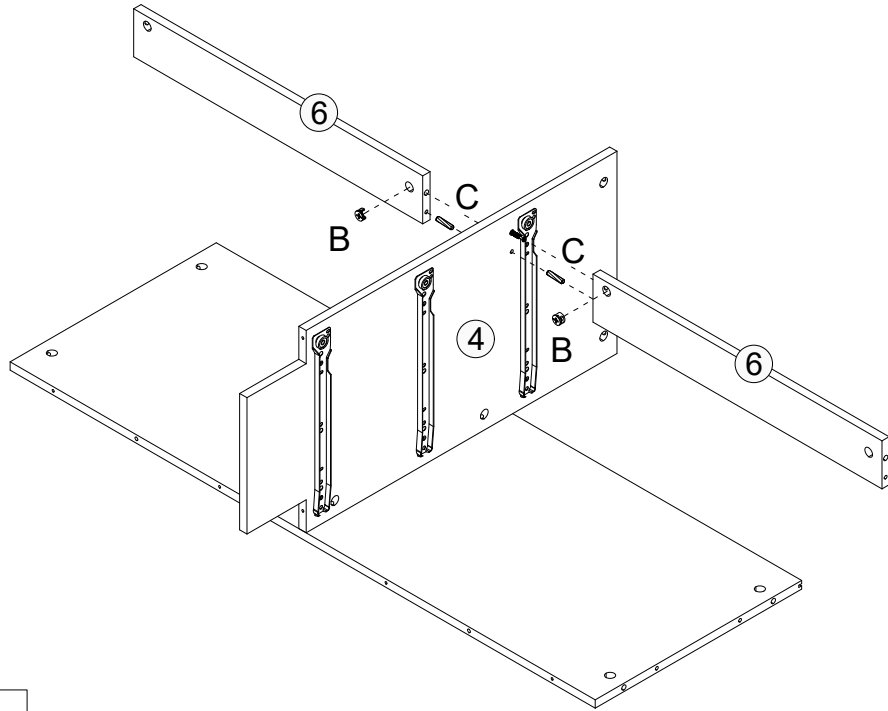

STEP 8

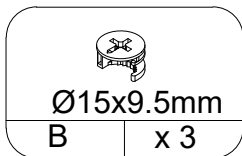
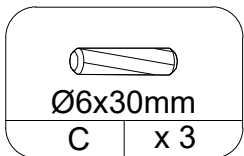
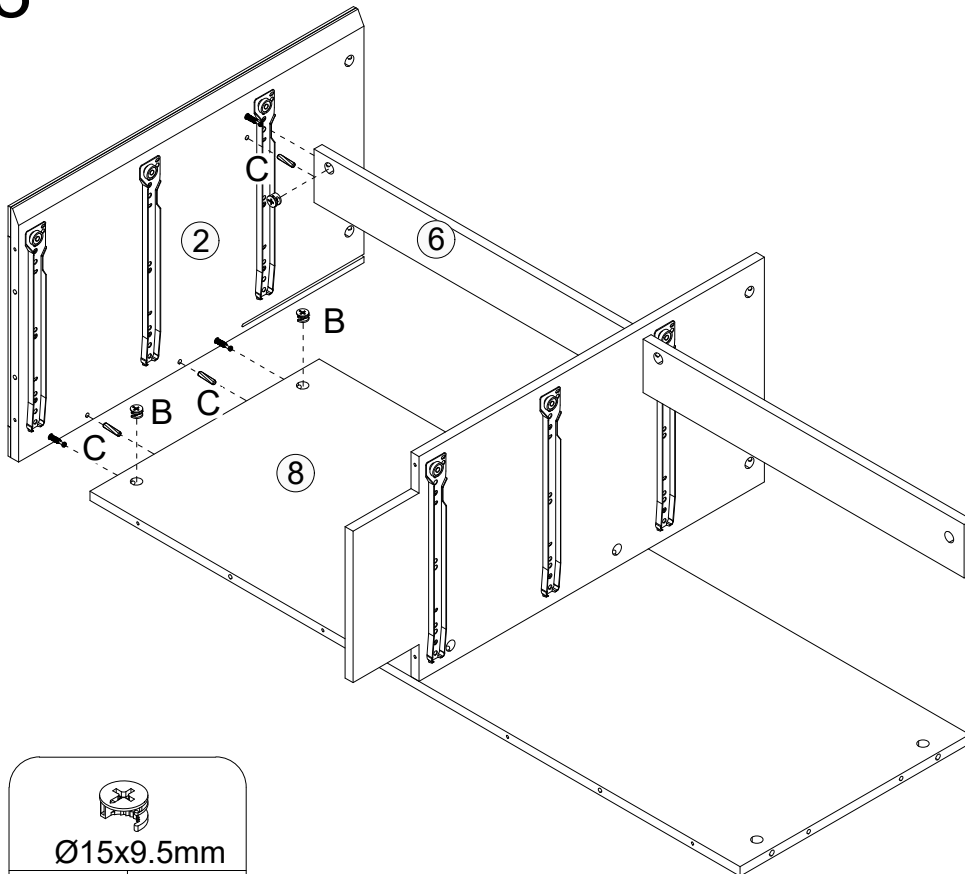

STEP 9

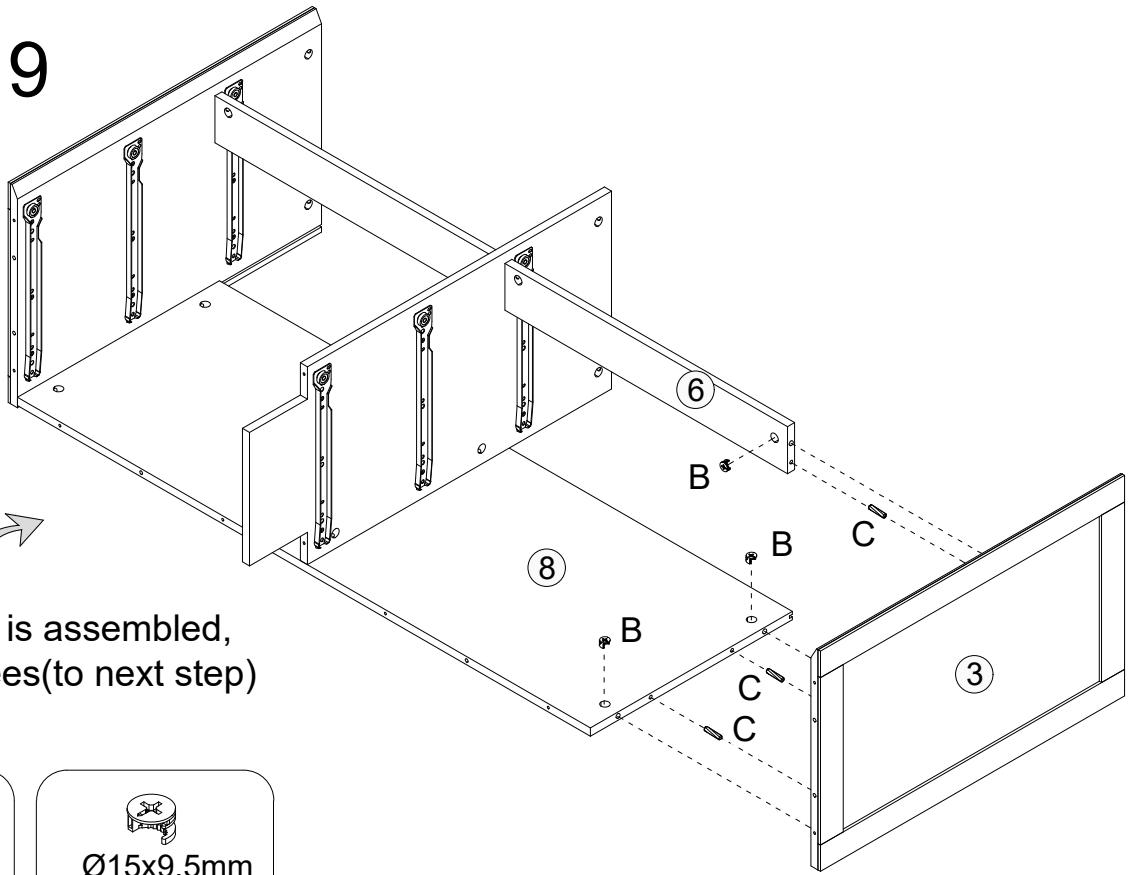

After this step is assembled, flip it 90 degrees (to next step)

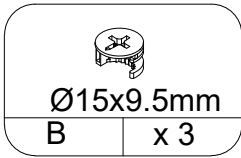
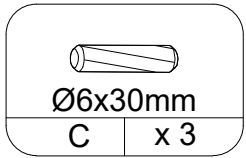

STEP 10

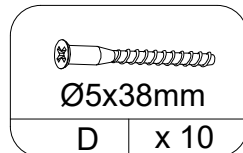
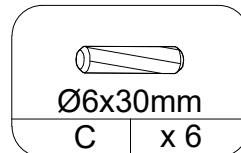
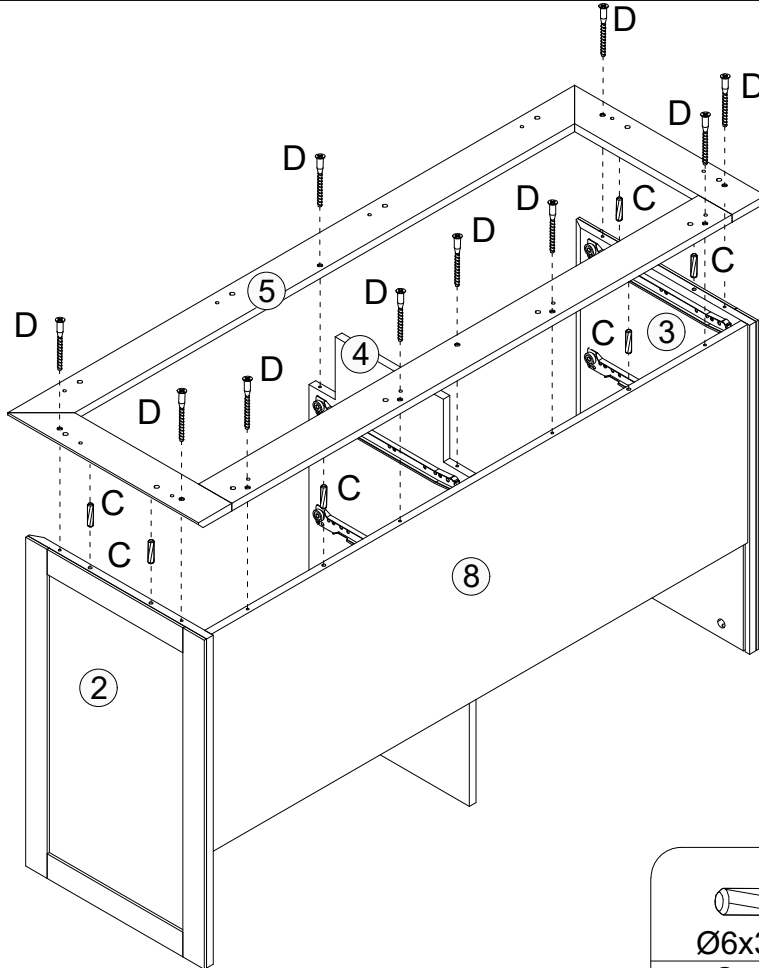

STEP 11

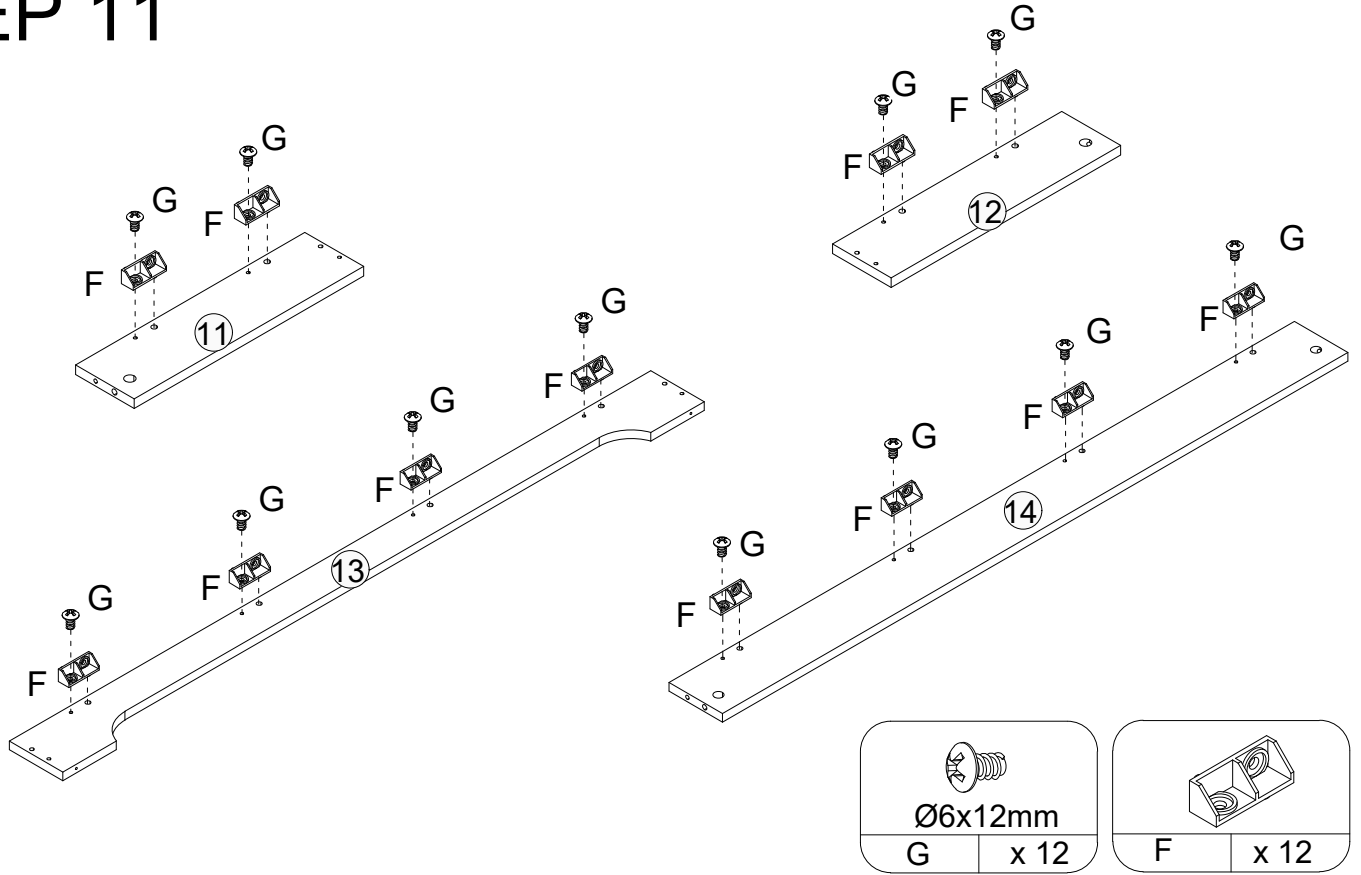

STEP 12

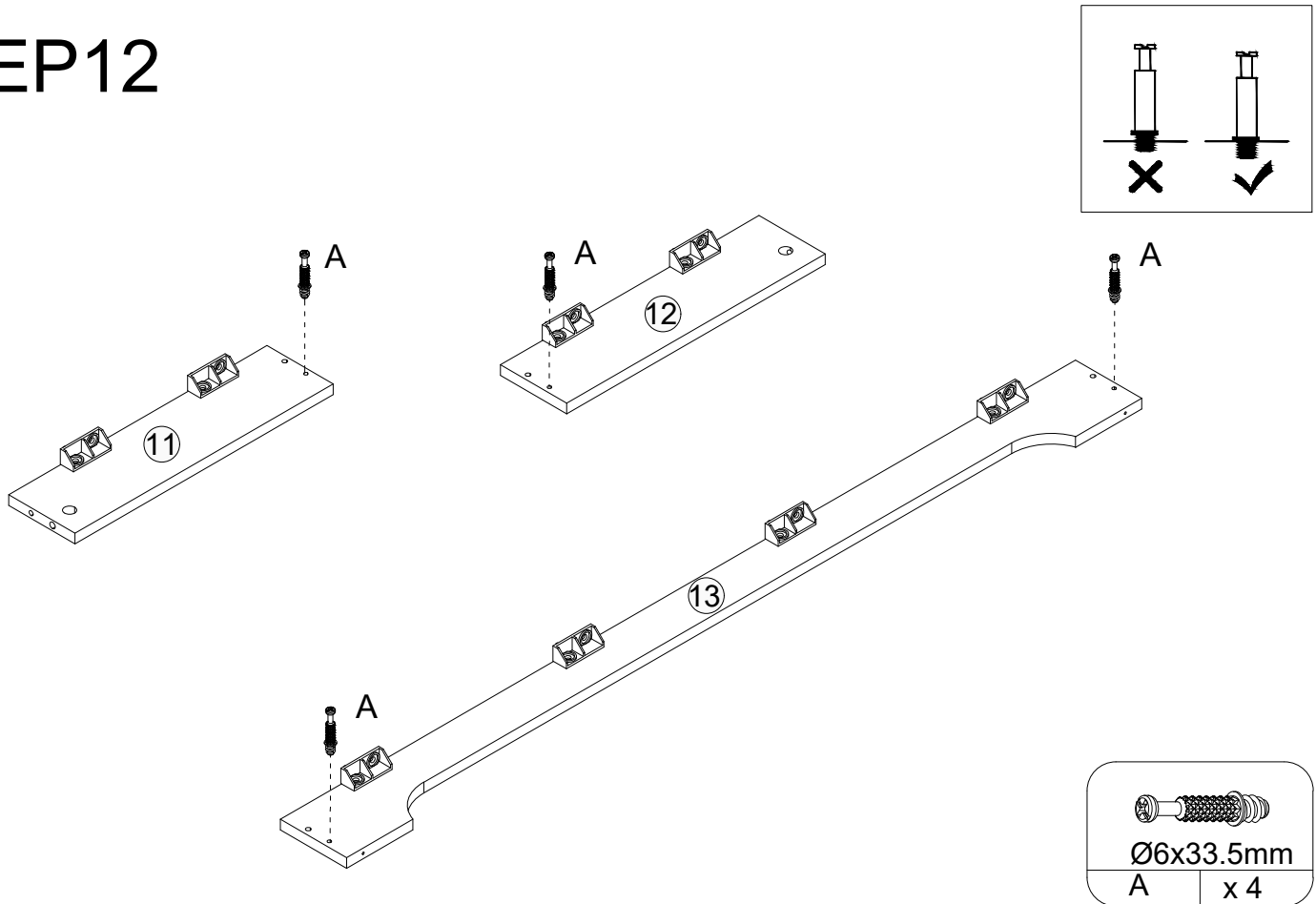

STEP 13

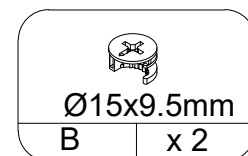
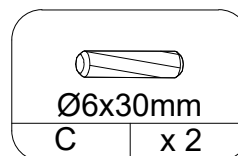
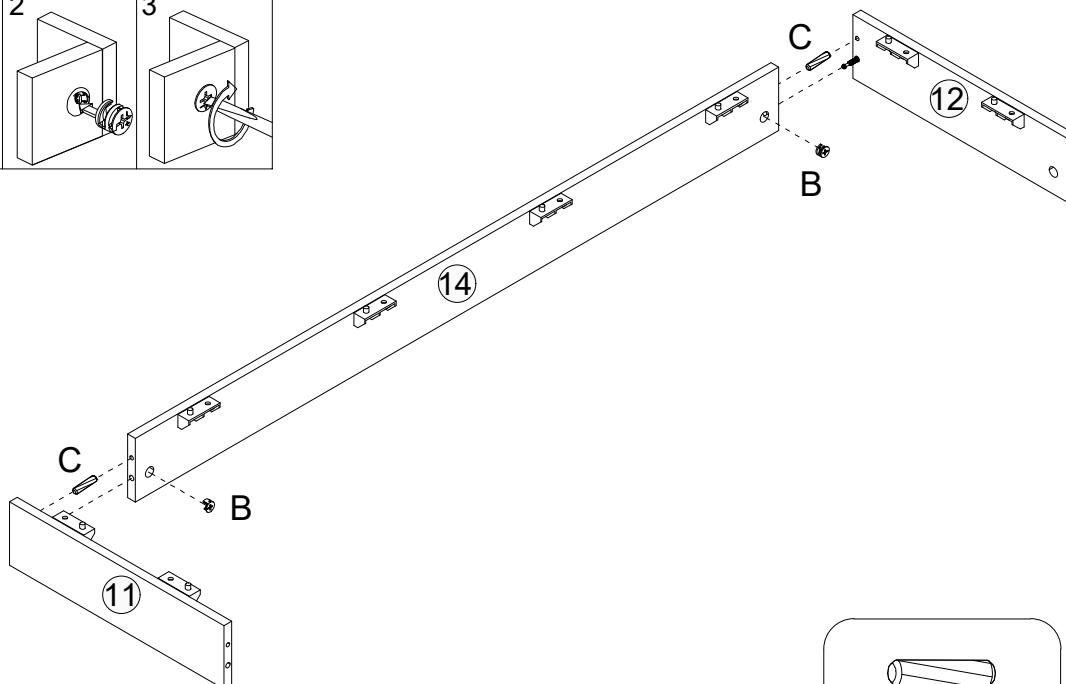
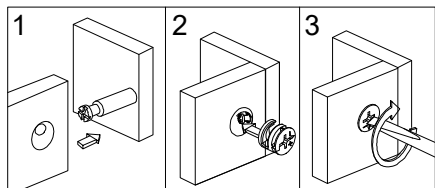

STEP 14

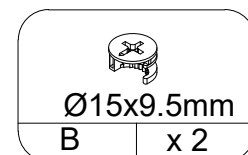
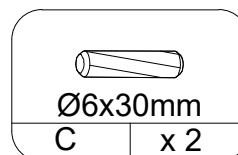
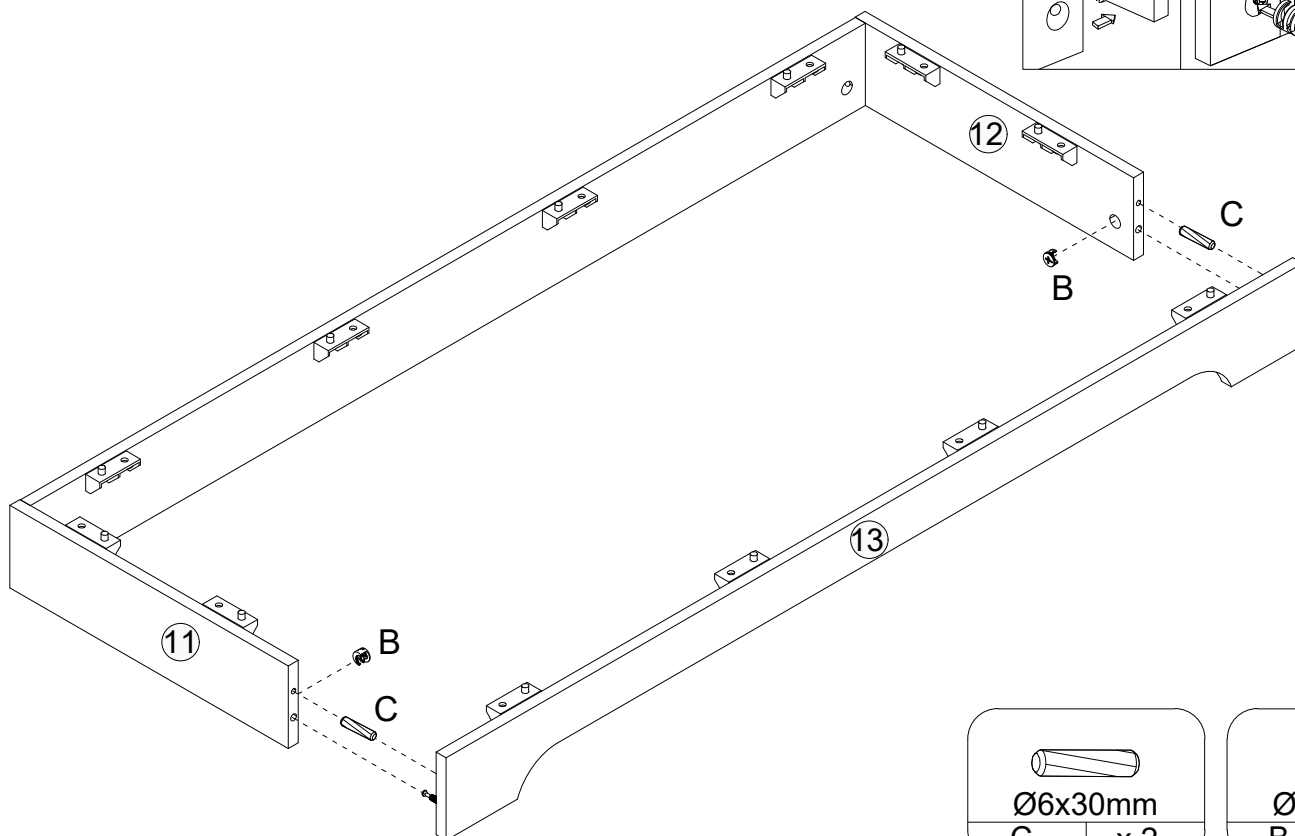
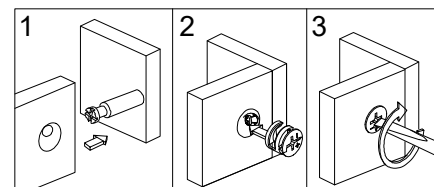

STEP 15

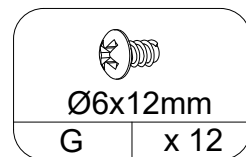
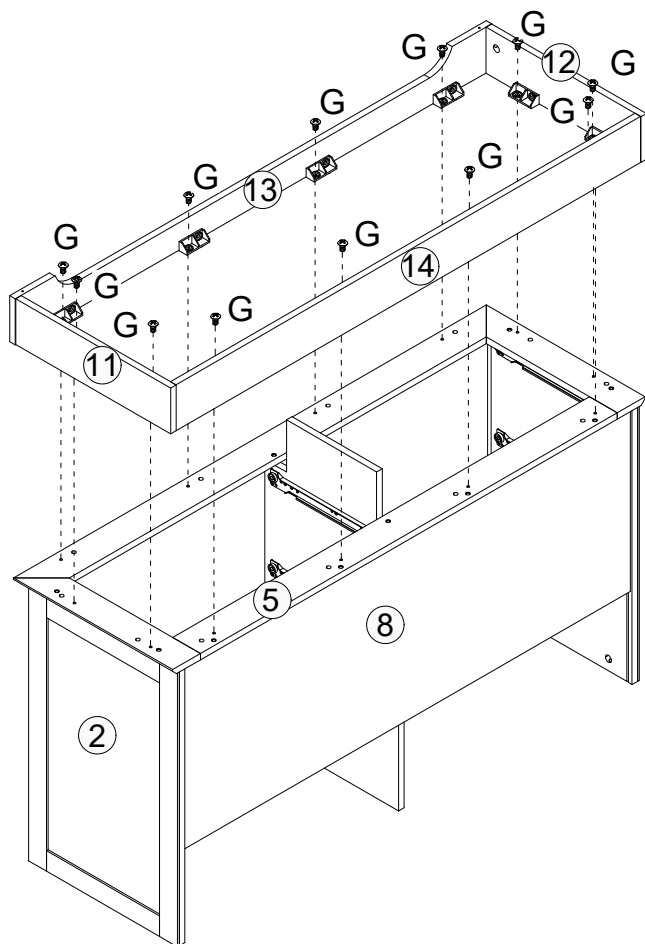

STEP 16

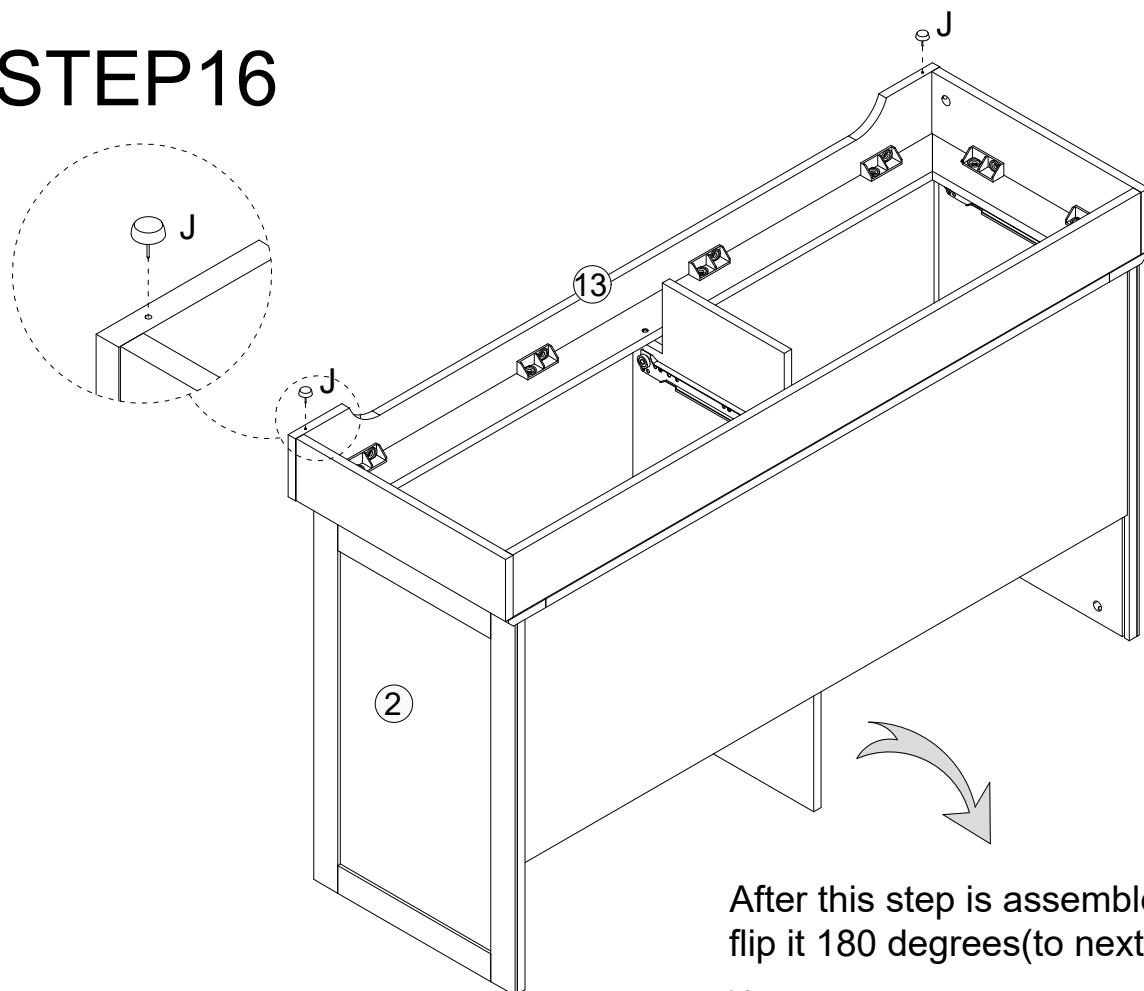

After this step is assembled,
flip it 180 degrees(to next step)

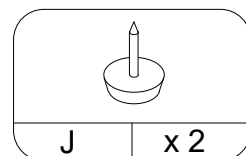

STEP 17

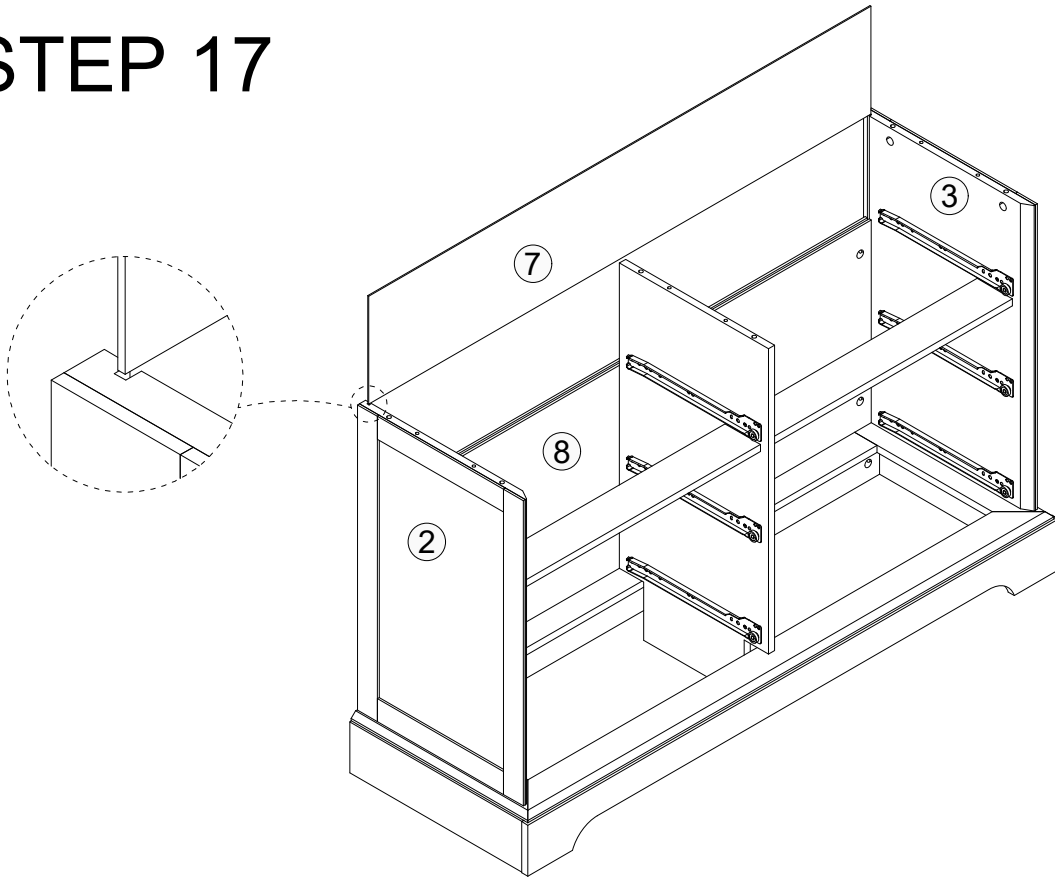

STEP 18

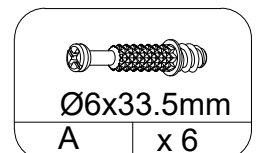
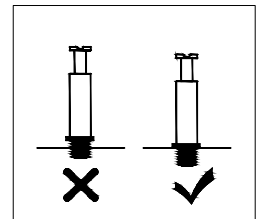
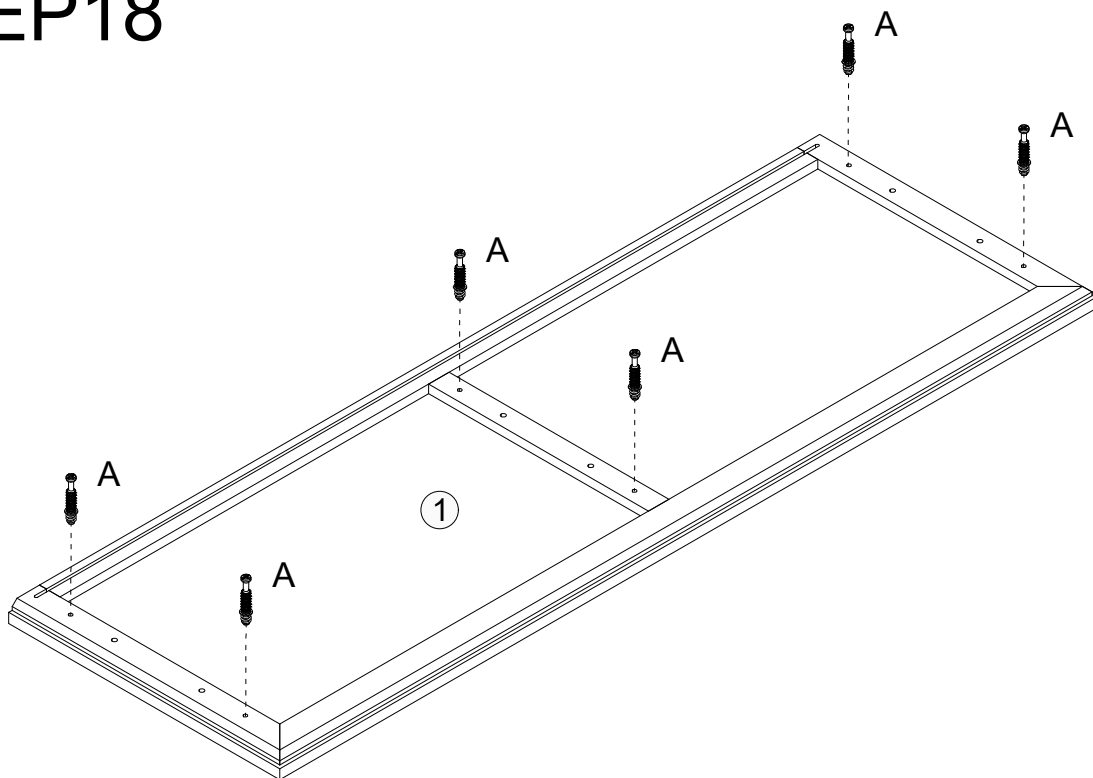

STEP 19

Back panel groove

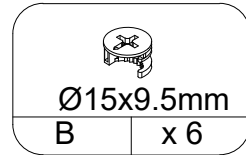
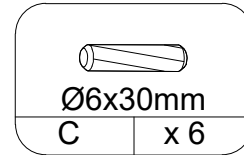
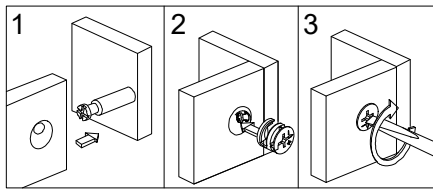
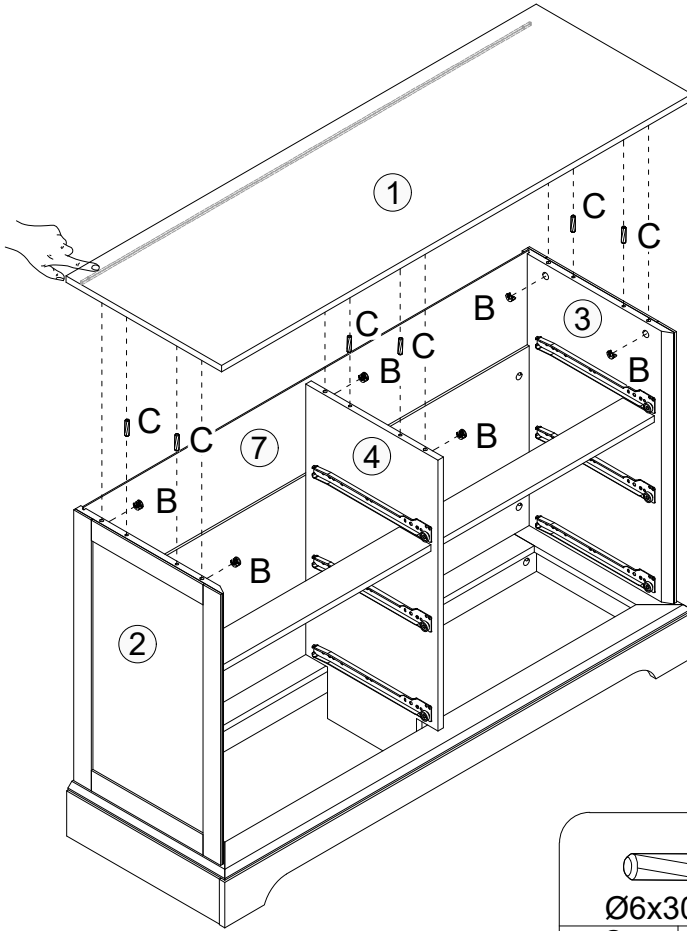

STEP 20

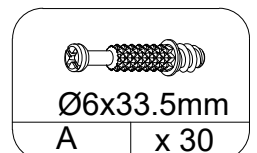
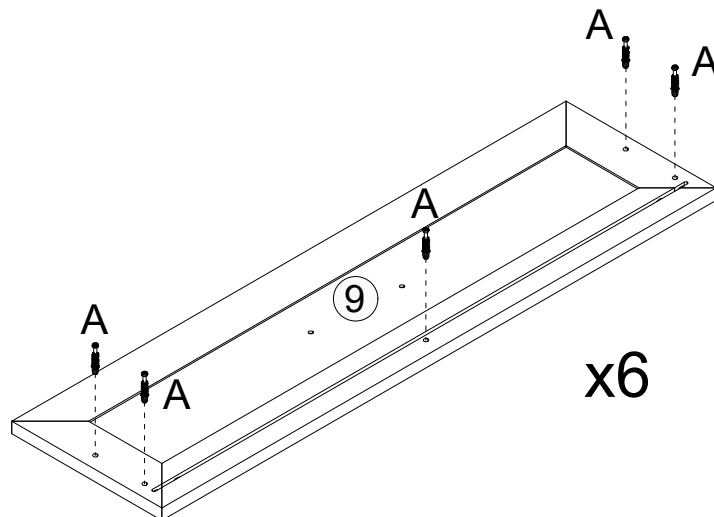
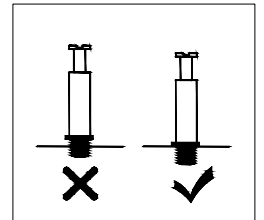

STEP 21

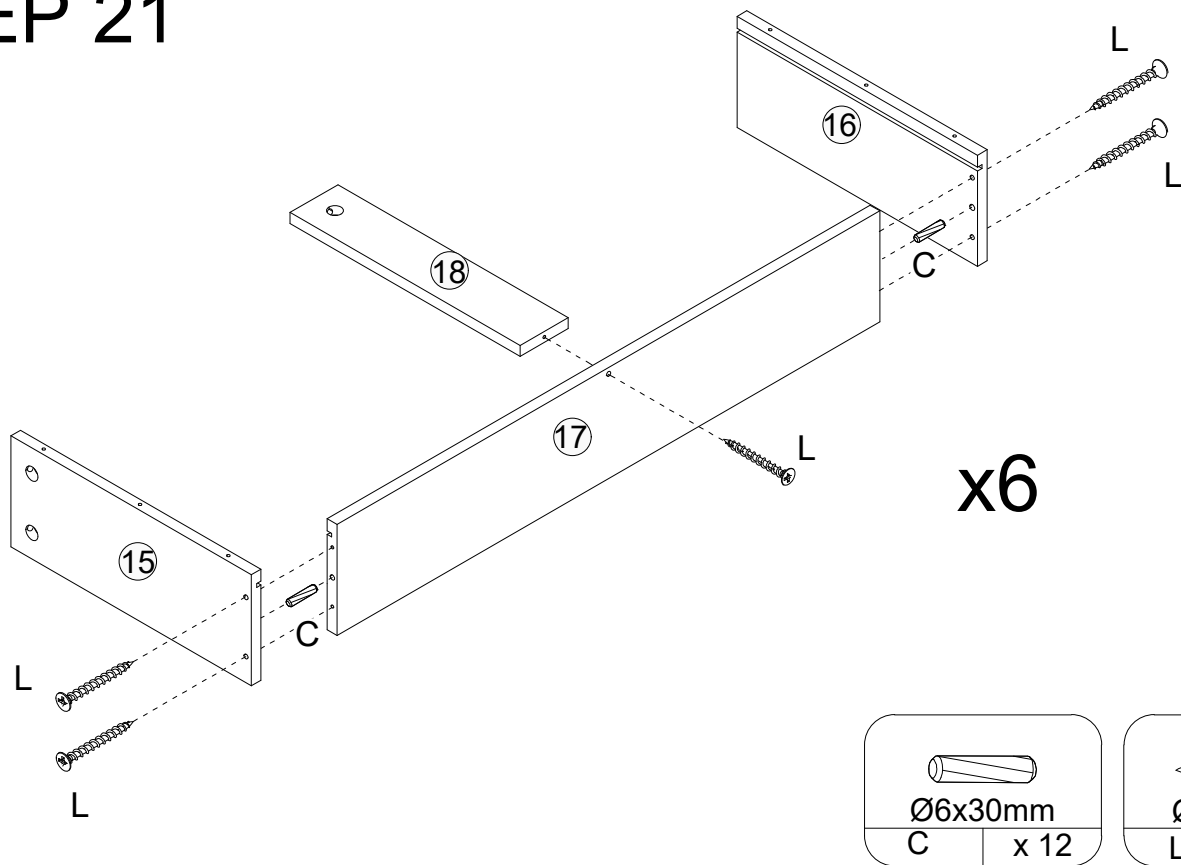

STEP 22

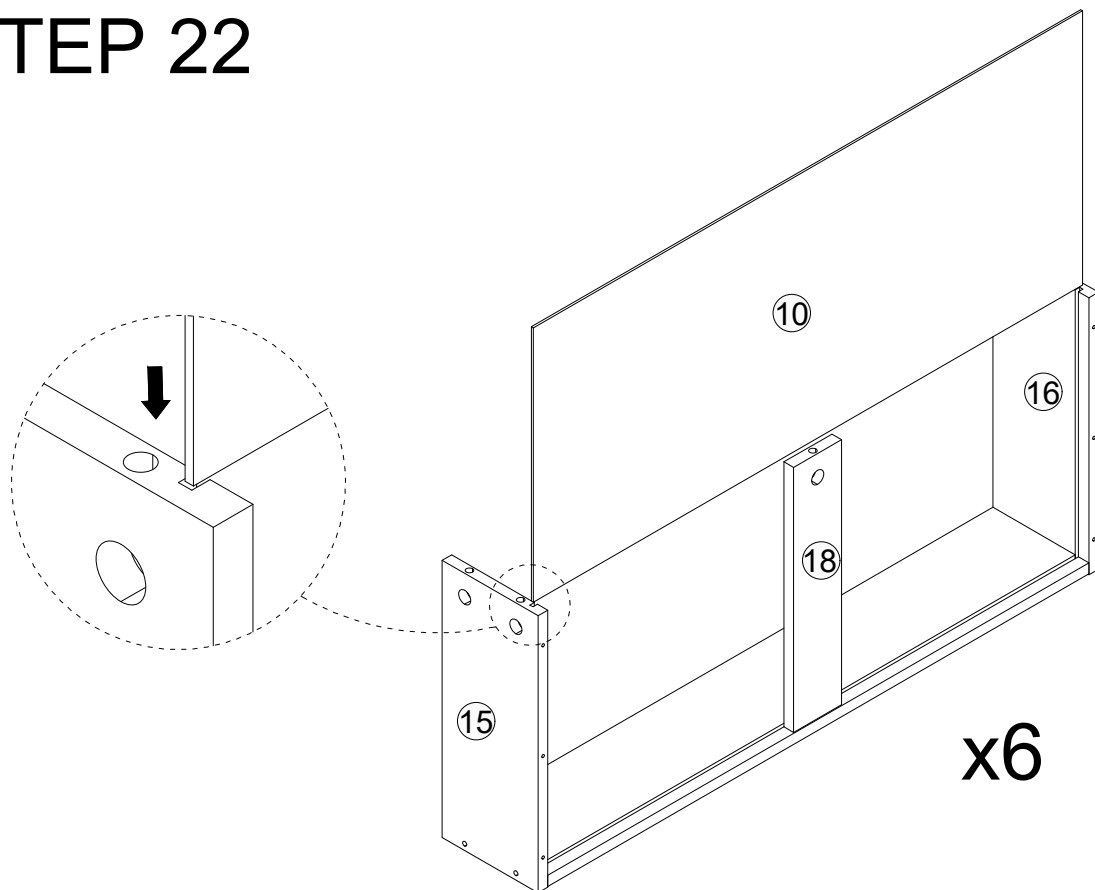

STEP 23

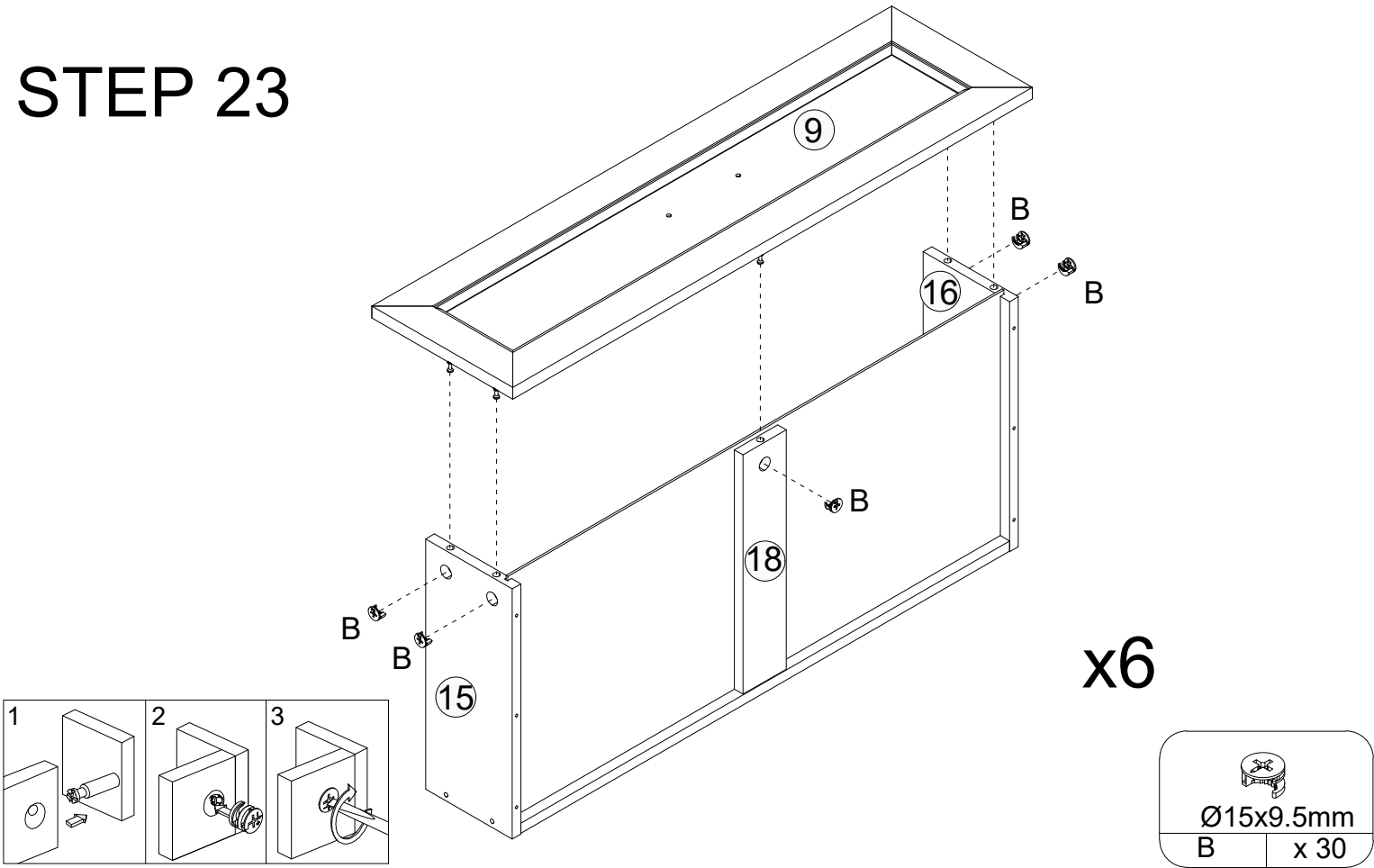

STEP 24

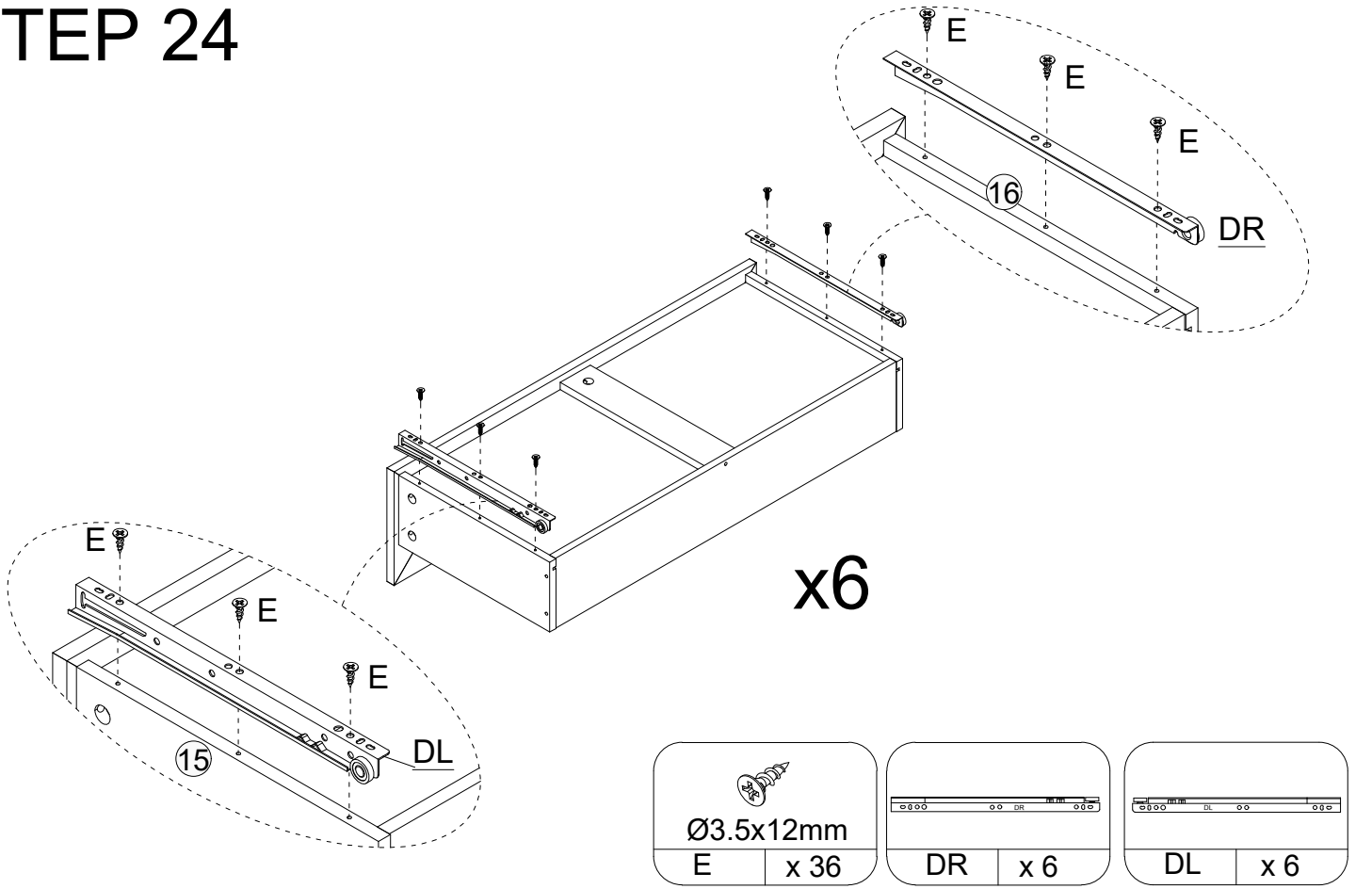

STEP 25

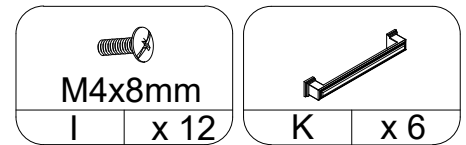
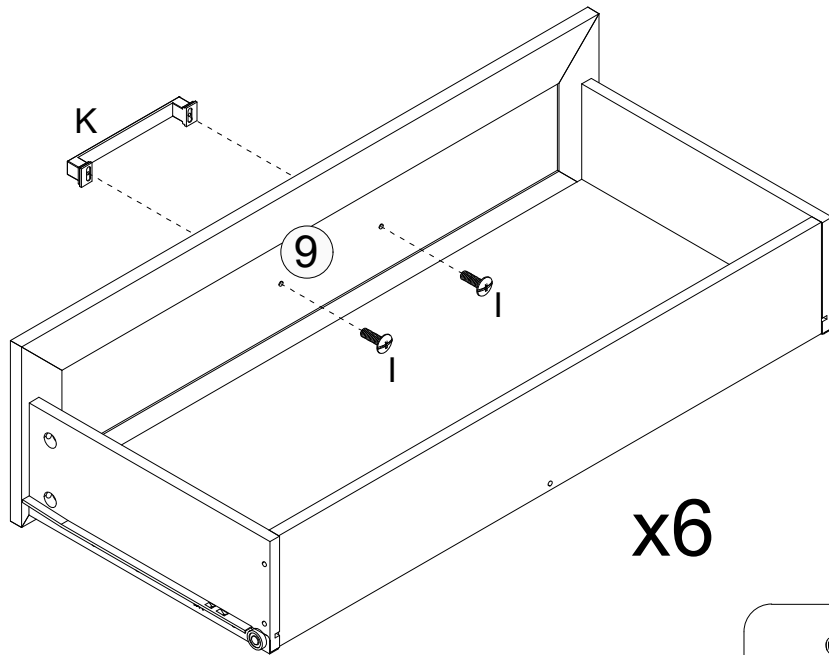

STEP 26

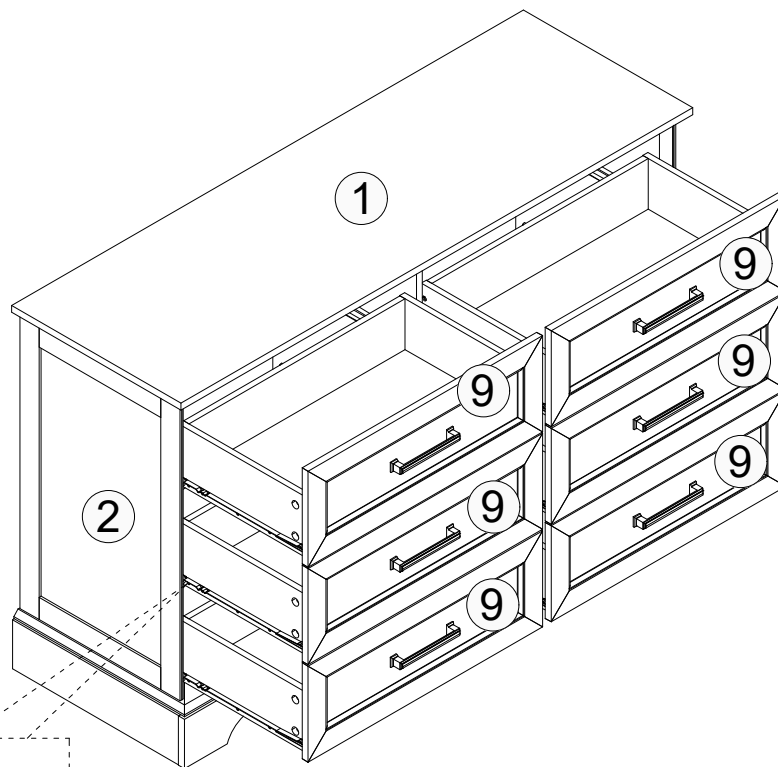

Cabinet Slide arms

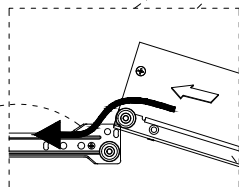

Drawer Slide brackets

STEP 27

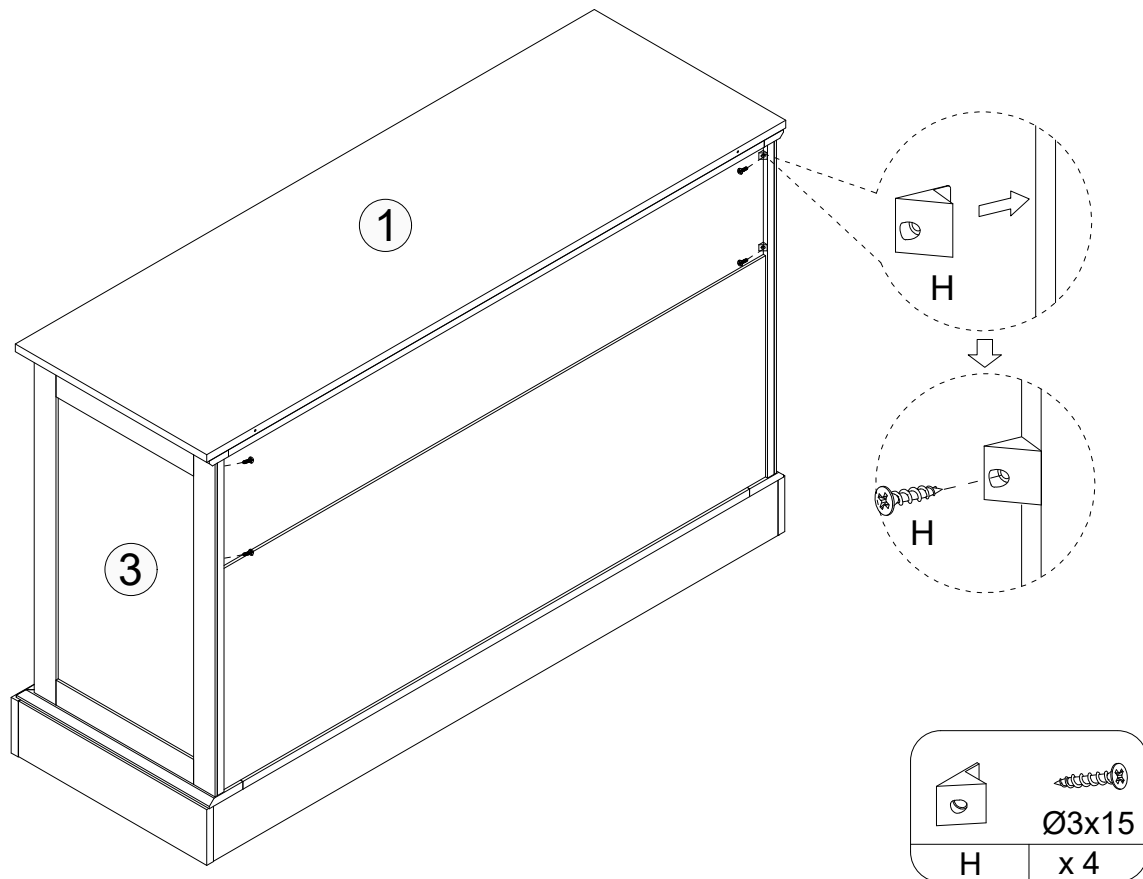

STEP 28

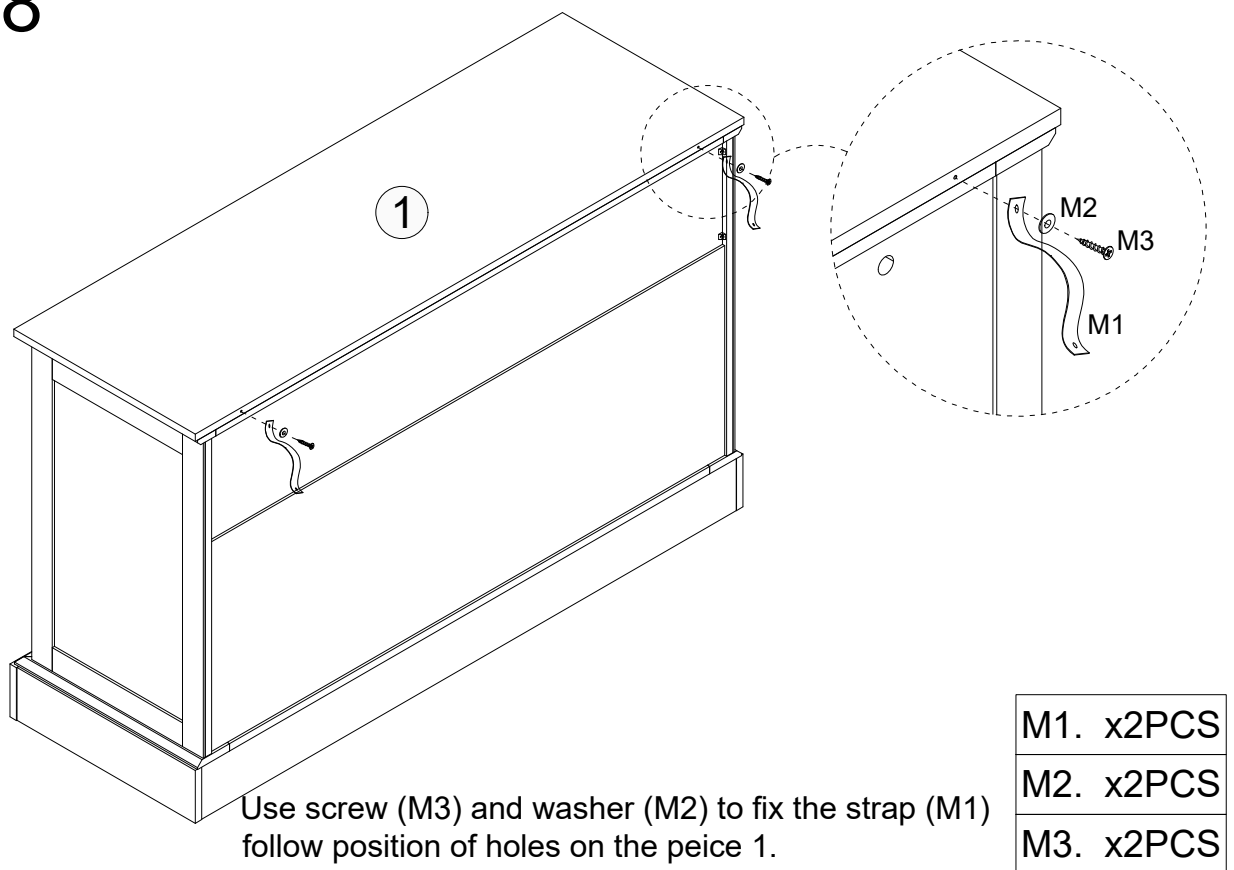

STEP 29

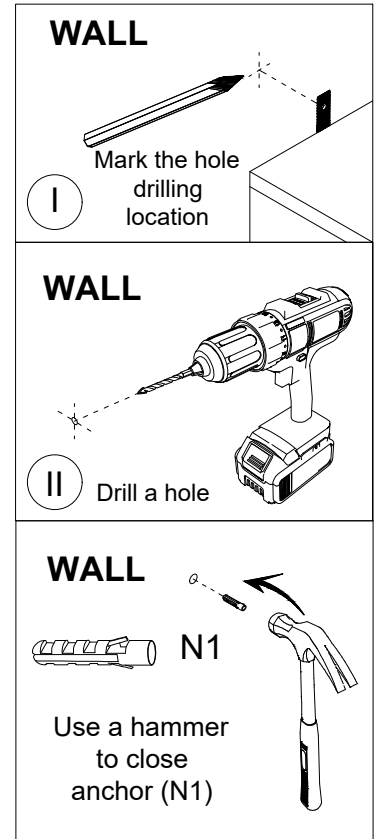
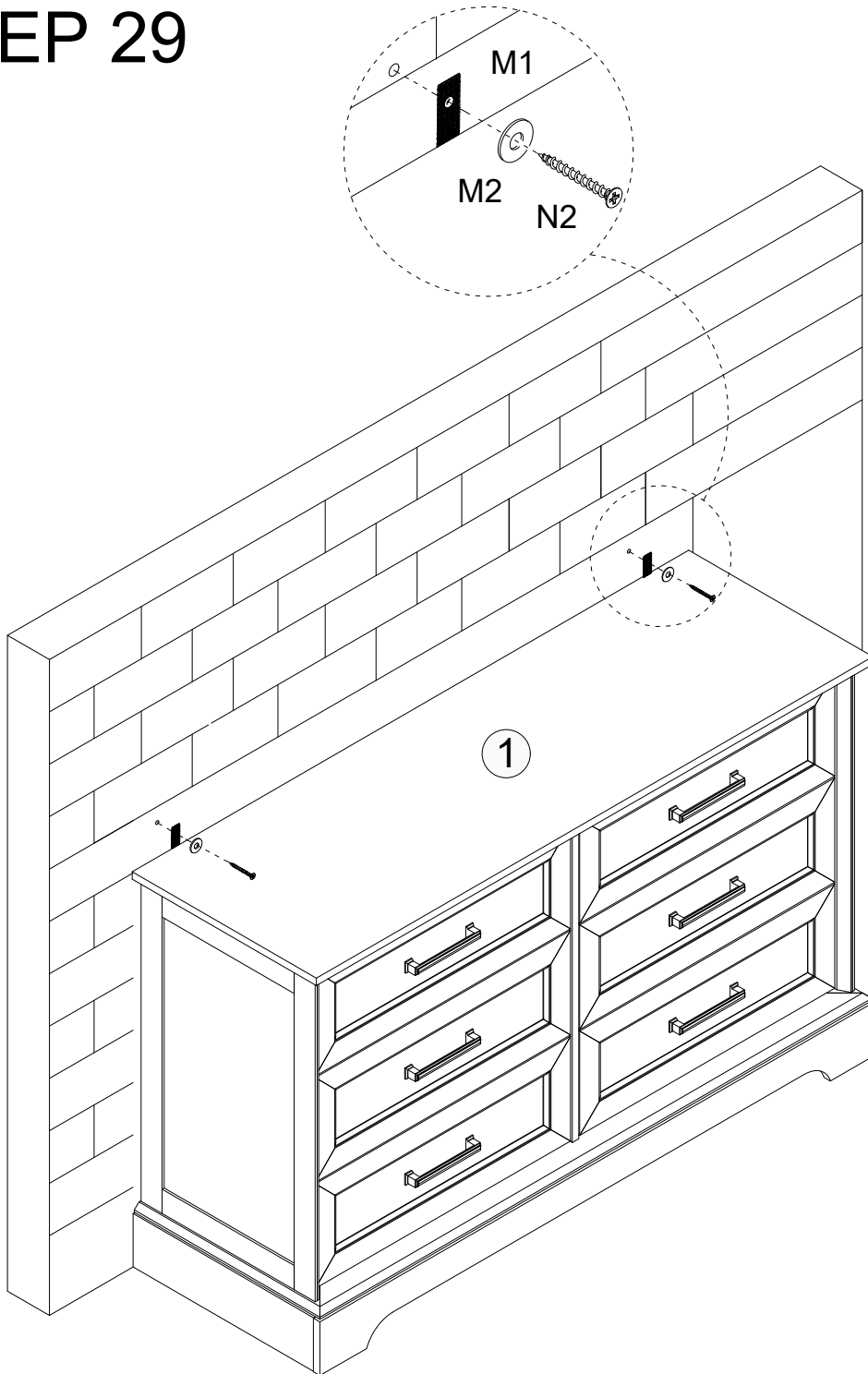

Step1: determine the location of the anti-overturning on the wall and then mark the position after confirming the product has been balanced.

Step 2: drill the hole and then fixed the anchor (N1) on the wall.

Step 3: use screw (N2) to fix the strap (M1), (M2) on the wall .

N1.	x2PCS
N2.	x2PCS
M2.	x2PCS

FURNITURE CARE AND MAINTENANCE

Medium - Density Fiberboard and Particle board

Thank you for your purchase. We want your item to last as long as possible. To ensure the product gives you years of service, please refer to this care and maintenance guide.



MAINTENANCE

- Tighten all bolts and screws again within the first 2 weeks of assembly
- Check the tightness of all bolts every 2 months, tighten them if necessary



CLEANING

- Clean the surface of the MDF (medium - density fiberboard) or PB (particle board) with a lightly dampened cloth.
- Small amount of mild soap can be used if necessary
 - Dry the surface immediately after cleaning.

⚠ DO NOT use bleach or alcohol detergent to clean the surface.

⚠ DO NOT apply wood treatment on parts made with MDF and PB.

Medium - density fiberboard and Particle board will swell and distort when suffer from water damage.

Make sure to dry the furniture immediately after cleaning