

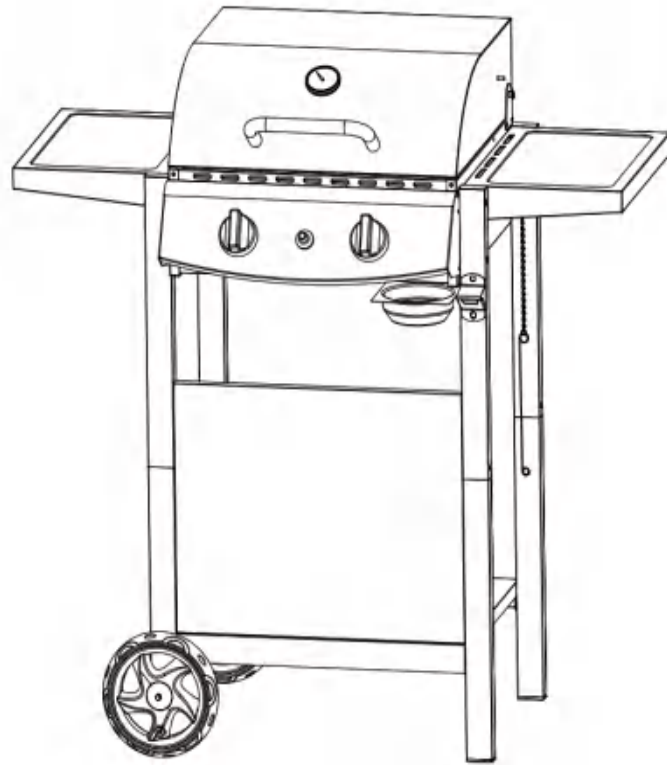

FOR OUTDOOR USE ONLY!

OUTDOOR BBQ GRILL

INSTRUCTION MANUAL



Model No.:G21-210A

Item No.:G8421-BLACK



WARNING

Improper installation, adjustment, alteration, service or maintenance can cause bodily injury or property damage. Read the installation, operation and maintenance instructions thoroughly before installing or servicing this equipment.



DANGER

Failure to follow these instructions could result in fire or explosion that could cause property damage, personal injury.



WARNING

DO NOT use gas grill for indoor cooking or heating. TOXIC fumes can accumulate and cause asphyxiation. DO NOT use in or on boats or recreational vehicles.

SAVE INSTRUCTIONS FOR FUTURE USE. IF YOU ARE ASSEMBLING THIS UNIT FOR SOMEONE ELSE, GIVE THEM THIS MANUAL FOR FUTURE USE.

Grill Operation 1-2-3

Before Grilling

- Step 1 Keep barbecue a safe distance away from building(s).*
- Step 2 Always perform a Leak Test on all connections and hoses.*
- Step 3 Keep children away from the barbecue.

During Grilling

(To avoid tripping safety valves, please follow these instructions carefully!)

- Step 1 Open barbecue lid and slowly turn on gas supply valve at the tank.
- Step 2 Turn on and light only one grill at a time.
- Step 3 Use protective gloves when grill gets hot.
- Step 4 Never leave a lit grill unattended.

After Grilling

- Step 1 Always burn grill for 10-15 minutes to burn off food residues after use.
- Step 2 Wait until grill is completely cooled before closing lid.
- Step 3 Remove grease to avoid hazardous build-up, and use the barbecue cover to prevent rust.

* Please refer to the owner's manual for details.



DANGER

1. **DO NOT** use or store gasoline or other flammable liquids or vapours in the vicinity of this appliance.
2. **DO NOT** store any other spare LP cylinder in the vicinity of this appliance.



DANGER

- IF YOU SMELL GAS -

1. **TURN OFF** gas.
2. **Extinguish** any open flame.
3. **Open** lid.
4. **If odour continues, get away from the appliance immediately. Call your gas supplier or dial 911.**

IMPORTANT, RETAIN FOR FUTURE REFERENCE: READ CAREFULLY!

To prevent possible bodily injury or property damage, read and understand the WARNINGS and INSTRUCTIONS in this manual before attempting to use the barbecue.

NOTE: This barbecue must be used with propane gas only (propane gas cylinder not included).

Installer: Leave this manual with the consumer.

Consumer: Retain this manual for future reference.

Table of Contents

For Your Safety	4
Package Parts List	6
Hardware Package List	7
Assembly Instructions	7
Operating Your Barbecue	13
Connecting & Disconnecting the Gas Cylinder	13
Checking for Leaks	14
Lighting Grill Burners	14
Excess Flow Safety Valve Reset Procedure	15
Care and Maintenance	17
Troubleshooting	18

For Your Safety

Read and understand all warnings and precautions prior to operating your barbecue.

WARNING

1. This barbecue is for outdoor use only. It should not be used in a building, garage or any other enclosed area.
2. The use of alcohol or prescription or non-prescription drugs may impair an individual's ability to properly assemble or safely operate this appliance.
3. Always open the barbecue lid carefully and slowly as heat and steam trapped within the grill area could cause severe burns.
4. Always place your barbecue on a hard and level surface far away from combustible materials and structures. An asphalt or blacktop surface may not be acceptable for this purpose.
5. Do not leave the barbecue unattended.
6. Keep children and pets away from the grill at all times.
7. This is not a tabletop barbecue. Do not place this barbecue on any type of tabletop surface.
8. Do not grill in high winds.
9. This barbecue must be used with propane gas only (propane gas cylinder not included).
10. Do not attempt to attach barbecue to the self-contained propane system of a camper, trailer, motor home or house.
11. Do not use charcoal or lighter fluid.
12. Do not use gasoline, kerosene or alcohol for lighting. The liquid propane (LP) gas supply cylinder must be constructed and marked in accordance with the specifications for LP gas cylinders of the National Standard of the Transportation of Dangerous Goods Commission of Canada for Cylinders, Spheres and Tubes (CAN/CSA-B139).
13. This outdoor gas appliance is not intended to be installed in or on recreation vehicles and/or boats.
14. Do not attempt to move the grill while it is lit.
15. Do not use the barbecue unless it is COMPLETELY assembled and all parts are securely fastened and tightened.
16. Keep combustible items and surfaces at least 2 m (6 ft) away from the unit at all times. DO NOT use this barbecue or any gas product under any overhead enclosure or near any unprotected combustible constructions.
17. Do not use in an explosive atmosphere. Keep grilling area clear and free from combustible materials, gasoline and other flammable vapours and liquids.
18. Do not attempt to use or assemble with missing or damaged parts. Contact customer service for replacement parts.

CAUTION - Prevention of Burns

1. To avoid burns, do not touch metal parts of the barbecue until they have completely cooled for at least 45 minutes or unless you are wearing protective gear such as pot holders, protective gloves or oven mitts.
2. Do not alter the barbecue in any manner.
3. Clean and inspect the gas hose before each use. If there is evidence of abrasion, wear, cuts or leaks, the hose must be replaced prior to operation. The replacement hose assembly should be in accordance with the manufacturer's specifications.
4. Move gas hoses as far away as possible from hot surfaces and dripping hot grease.
5. Never keep a filled LP gas cylinder in a hot car or car trunk. Heat will cause the gas pressure to increase, which could open the relief valve and allow gas to escape.

Safe Locations for Use of This Outdoor Grill

CAUTION

Never use this outdoor barbecue inside any building, garage, shed or breezeway; or inside any boat, trailer or recreational vehicle, to prevent a possible fire and to prevent the possibility of carbon monoxide poisoning or asphyxiation.

WARNING

Do not use barbecue under an overhead combustible surface or covered area (e.g., awnings, umbrellas, porches or gazebos). Always confirm that this unit is not positioned under the overhang of a house, garage or other structure before lighting it. An overhang will serve to deflect flare-ups and radiated heat into the structure itself, which could result in a fire.

Always confirm that the barbecue is positioned more than 126 cm (50 in) away from any building or combustible materials or surface before lighting it, and that no gasoline or other volatile substances are stored in the vicinity of this barbecue. (See diagram to right). Otherwise, the temperature of a grease fire, or of the radiated heat might be sufficient to ignite nearby combustible or volatile substances. Always locate the unit where there will be ample combustion and ventilation air, but never position it in the direct path of a strong wind.

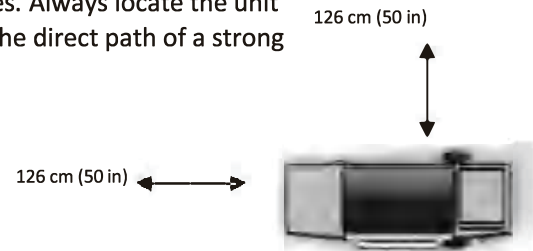

Never leave grill burners lit while unattended to prevent uncontrolled grease fires from erupting.

Never attempt to move the unit while it is in operation or while it is still hot to prevent possible personal injury.

Never store or use gasoline or other flammable or volatile substances in the vicinity of this or any other heat-generating appliance because of the danger of starting a fire.

Always confirm that the installation of this barbecue conforms to the requirements of all local codes or, in the absence of applicable local codes, with the Canadian Standards Association's Natural Gas and Propane Installation Code CSA B149.1:20

DANGER – Gas Safety

Liquid propane (LP) gas is flammable and hazardous if handled improperly. Become aware of its characteristics before using any propane product.

- Propane characteristics: Flammable, explosive under pressure, heavier than air and settles in pools in low areas.
- In its natural state, propane has no odour. For your safety, an odorant has been added.
- Contact with propane could cause freeze burns to the skin.
- This barbecue is shipped from the factory for propane gas use only.
- Never use a propane cylinder with a damaged body, valve, collar or footing.
- Dented or rusted propane cylinders may be hazardous and should be checked by your propane gas supplier.

CAUTION

- It is essential to keep the barbecue's valve compartment, burners and circulating air passages clean.
- Inspect the barbecue before each use.
 - Step 1. Inspect all hoses and connections and make certain they are secure.
 - Step 2. Check and clean the burner venturi tubes for insects and insect nests by removing the burner and inserting a bottle brush cleaner into each tube to make sure the passage is clear.
*** A clogged tube can lead to a fire beneath the grill. ***
 - Step 3. Ensure that the valve nozzle is pointing straight and completely inserted into the venturi tube.

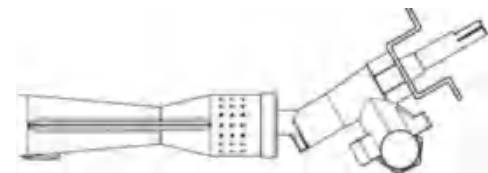





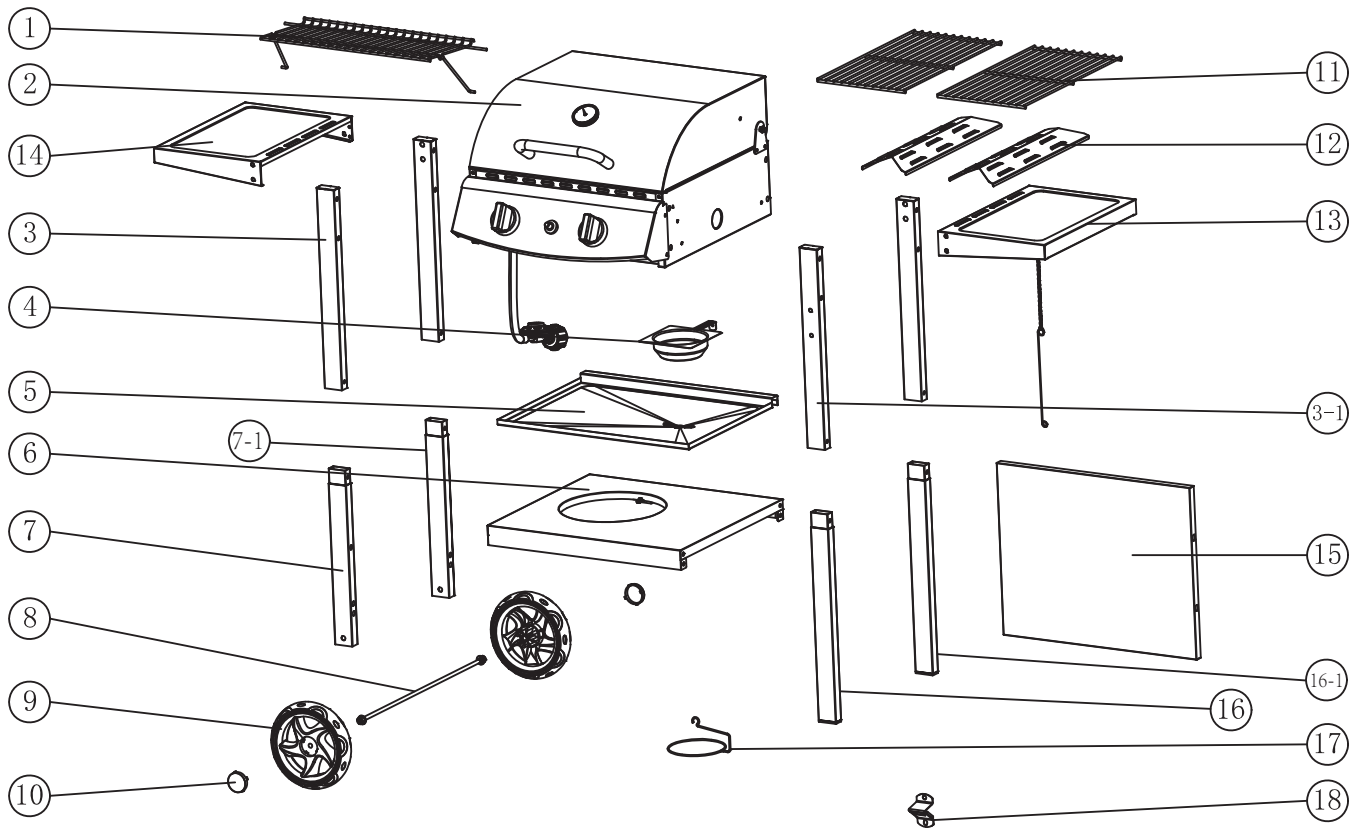



GENERAL INFORMATION

1. A propane gas cylinder is required for operation.
2. This gas barbecue is NOT intended for commercial use.
3. Don't obstruct the ventilation opening of the cylinder enclosure.

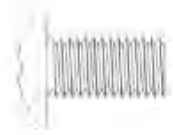

Serial#	Part name	QTY	Serial#	Part name	QTY
1	Warming rack	1	10	Wheel cap	2
2	Body assembly	1	11	Cooking grid	2
3	Upper Leg (Left front/ left back/ right back)	3	12	Heat shield	2
3-1	Upper leg (Right front)	1	13	Right side shelf	1
4	Grease cup	1	14	Left side shelf	1
5	Grease pan	1	15	Front panel	1
6	Bottom panel	1	16	Right lower leg (Front)	1
7	Left lower leg (Front)	1	16-1	Right lower leg (Back)	1
7-1	Left lower leg (Back)	1	17	Grease cup holder	1
8	Wheel axle	1	18	Bottle opener	1
9	Wheel	2			

Hardware List

A: 18x	B: 2x	C: 2x	D: 12x
			
M6×12 Bolt	Flat washer	M8 Nut	M6×50 Bolt
E: 2x	F: 4x	G: 1x	H: 2x
			
M5 x 12	M6 Nut	Screwdriver	Wrench
I: 1x			
			
Retainer wire			

Assembly Instructions



Assembly time: about 30 minutes
2 Persons

Step 1

- 1) Align the holes on the Left Lower Legs (7) and (7-1) with the holes on the Bottom Panel (6), then attach one M6x12 Bolt (A) into each hole, tighten the bolt by hand.
- 2) Repeat the same procedure to assemble the Right Lower Legs (16) and (16-1), and go back to tighten all the bolts with screwdriver provided.

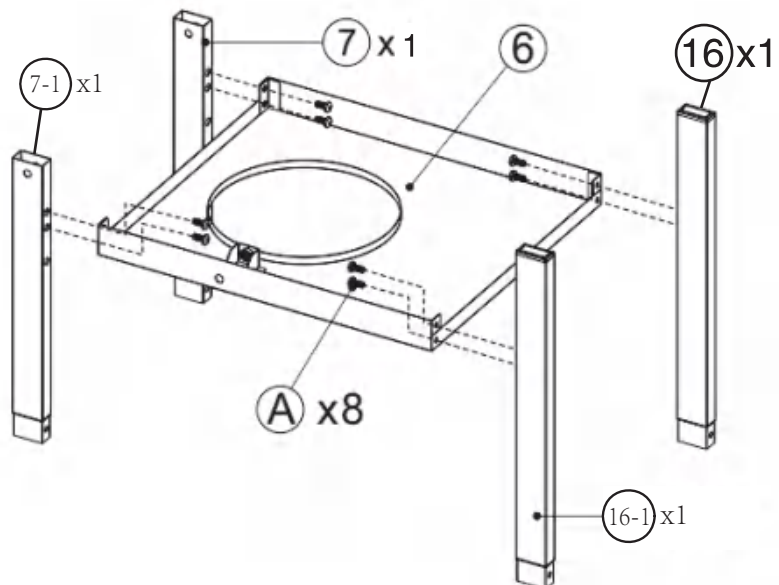

Step 2

- 1) Insert the Wheel Axle (8) into the holes of Left lower legs, then attach one Flat Washer (B), one Wheel (9) and one M8 nut (C) onto both end of the wheel Axle.
- 2) Hold one nut with one wrench and tighten the other nut with another wrench. then repeat the same procedure to tighten the nut just held.
- 3) Attach the wheel caps (10) onto both end of Wheel Axle.

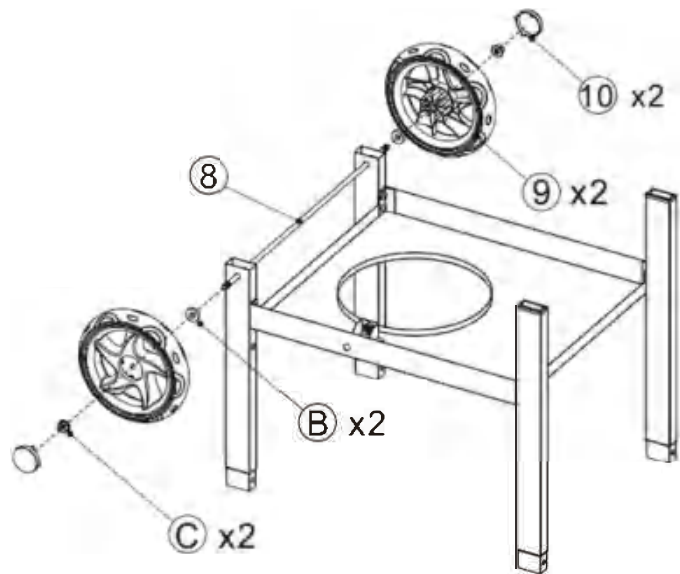

Step 3

Insert the lower legs into upper legs (3), align the holes on upper legs and lower legs.

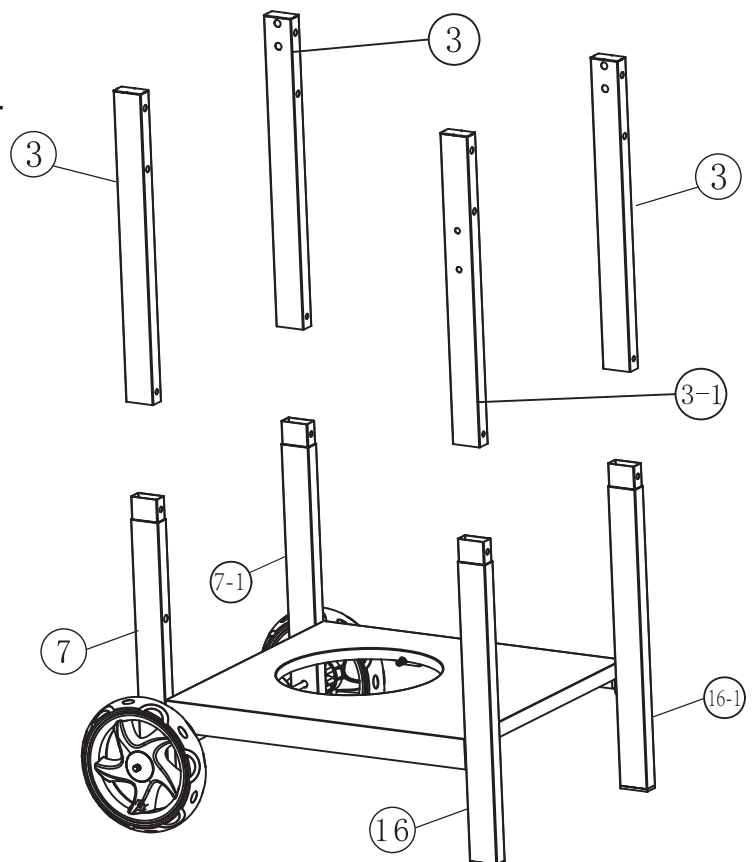

Step 4

- 1) Align the holes on the top of upper of the front panel with the holes on the connected front legs, then insert one M6x50 bolt (D) into each hole, and lock each bolt with one M6 nut (F).
- 2) Align the holes on the bottom of front panel (15) with the holes on bottom of the front legs, then insert one M6x12 bolt (A) into each hole, then tighten the bolts.
- 3) Insert one M6x50 bolt (D) into each hole of the connected back legs, and lock each bolt with one M6 nut (F).

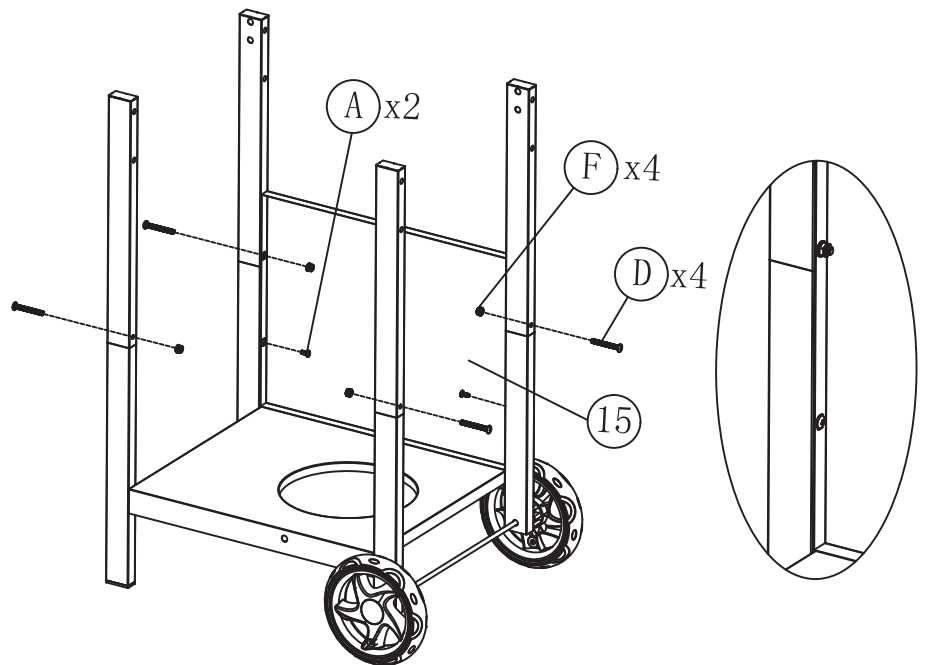

Step 5

- 1) Place the grill upside down as shown.

- 2) Align the holes on the leg and with the holes on the Left and Right side shelf (14), (13), insert M6x12 bolt (A) into each hole, then tighten with screwdriver.

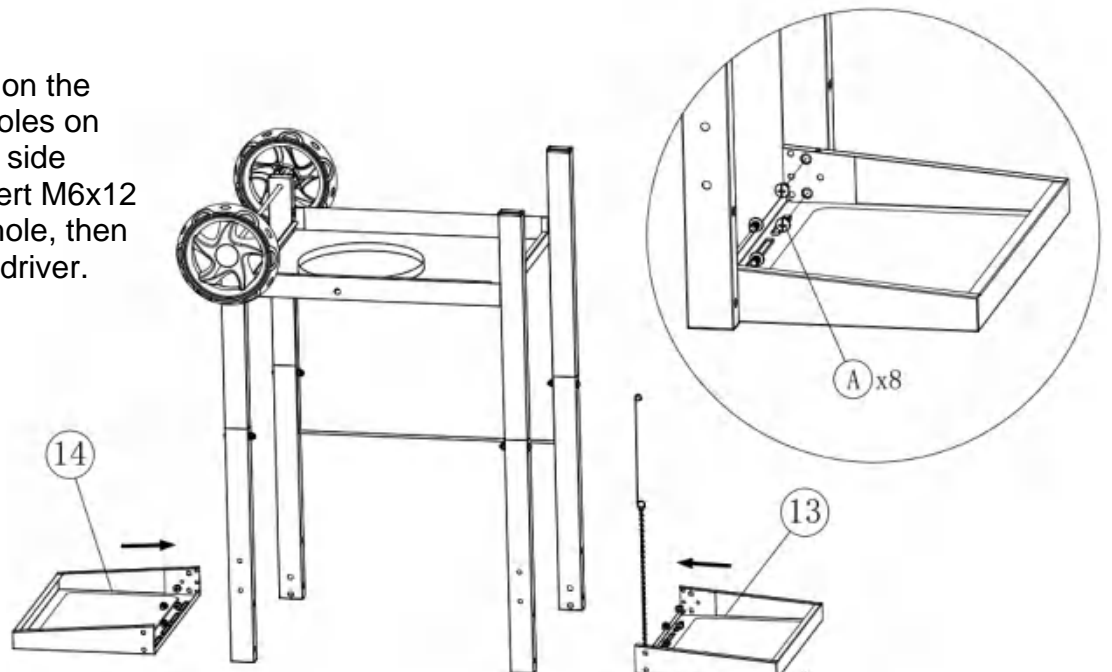

Step 6

Align the holes of Body assembly (2) and Leg tube.
Insert M6x50 bolt (D) to the bottom 4 holes first.
Then insert M6x50 bolt (D) to the top 4 holes.
Tighten with screwdriver.

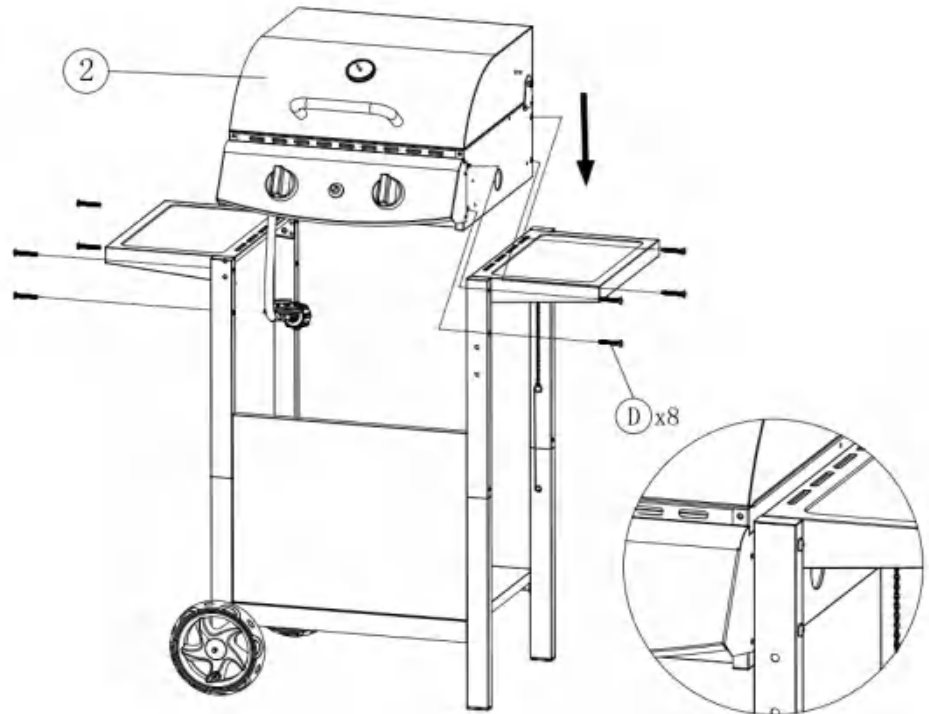

Step 7

1) Assemble the Bottle opener(18)
with M5x12 screws(E).

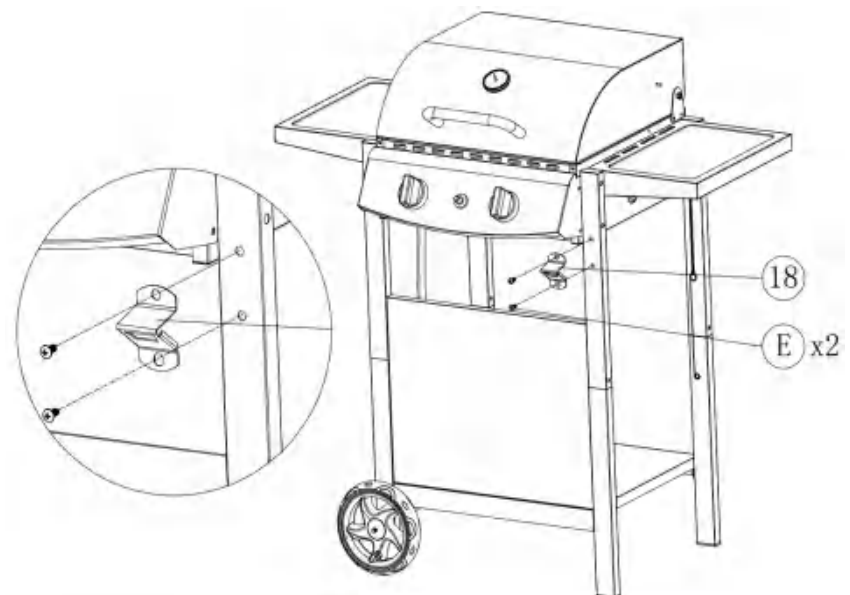

Step 8

- 1) Install Heat shields(12) over main burners.
- 2) Place Cooking Grid (11) over Heat shields.
- 3) Install Warming Rack (1) as the figure shows.

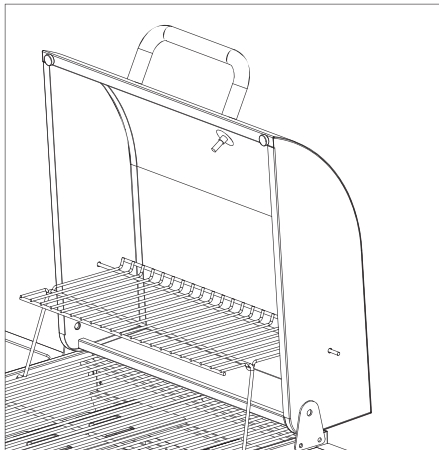

Step 9

- 1) Insert the Grease Pan (5) from the back of the grill
- 2) Hook the Grease Cup holder (17) on the Grease pan
- 3) Put the Grease Cup (4) on the Grease Cup Holder

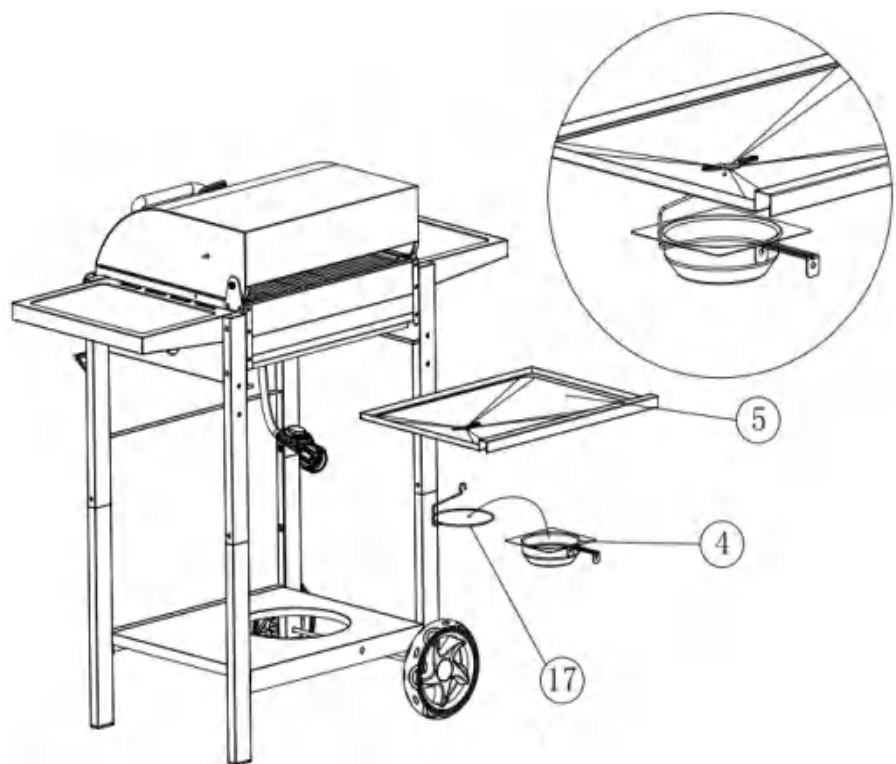

Step 10

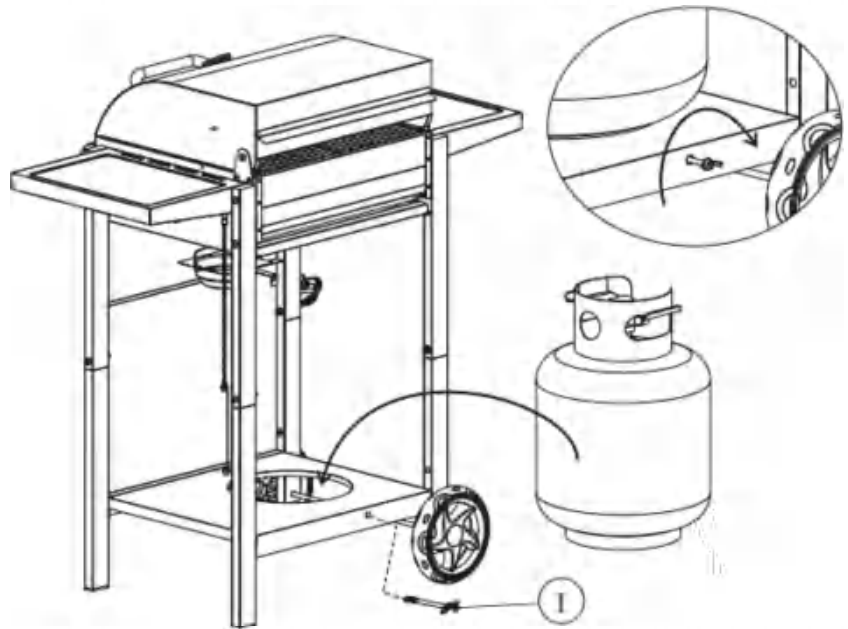

- 1) Put the gas tank (sold separately) on the tank support
- 2) Connect the regulator to the tank by turning it clockwise
- 3) Screw the retainer wire (I) until secure

Operating Your Barbecue

WARNING

Use only the regulator provided. If a replacement is necessary, call our customer service centre. The use of unauthorized parts can create an unsafe condition and environment. The liquid propane gas (LP gas) supply cylinder(s) to be used must be:

- a) constructed and marked in accordance with the Specifications for LP gas Cylinders of the U.S. Department of Transportation (D.O.T.) or the Standard for Cylinders, Spheres and Tubes for Transportation of Dangerous Goods and Commission, CAN/CSA-B339, as applicable;
- b) Provided with a listed over-filling prevention device;
- c) Provided with a cylinder connection device compatible with the connection for outdoor cooking appliances.

Only the pressure regulator and hose assembly supplied with the outdoor cooking gas appliance must be used. Replacement pressure regulators and hose assembly must be those specified by the outdoor cooking gas appliance manufacturer. Use only 20-pound cylinders equipped with a cylinder connection device compatible with the connection for outdoor cooking appliances.

The cylinder must include a collar to protect the cylinder valve. Do not drop or handle the cylinder roughly. If the outdoor cooking gas appliance is not in use, the gas must be turned off at the supply cylinder.

Storage of the appliance indoors is permissible ONLY if the cylinder is disconnected and removed from the appliance. Store cylinder outdoors and keep out of the reach of children. Do not store the cylinder in a building, garage or other enclosed areas.

Never store your cylinder where temperatures can reach over 51.7°C.

Before connecting, make sure there is no debris caught in the head of the gas cylinder, regulator valve or in the head of the burner and burner ports. Connect regulator valve and hand-tighten firmly. DO NOT obstruct the flow of combustion air or ventilation air to the grill. Ensure the propane cylinder is in an upright position to allow the gas to leave the cylinder. Otherwise, the overfill prevention device within the cylinder will prevent proper gas flow.

DANGER

A fire causing death or serious injury may occur if the following are not followed exactly:

Never store or use gasoline or other volatile substances in the vicinity of this barbecue.

- 1) Do not store a spare LP gas cylinder under or near this appliance;
- 2) Never fill the cylinder beyond 80 percent full;
- 3) If the information in Clause 4.25.2b)xii)i) and Clause 4.25.2b)xii)ii) is not followed exactly, a fire causing death or serious injury may occur.

This barbecue is designed to connect to a standard 20-lb cylinder only. Please refer to Step 10 of the Assembly Instructions for installation.

WARNING

Don't store spare gas cylinder in or near the barbecue.

Connecting & Disconnecting the Gas Cylinder

LP (Propane) Gas Supply Connection & Disconnection

1. Always place the propane cylinder on the tank brackets located on the right side of the cart.
2. Always confirm all burner control knobs are in the OFF position before activating the gas supply.
3. Before connection, be sure that there is no debris caught in the head of the gas cylinder, head of the regulator valve, or in the head of the burner and burner ports.
4. Always connect the gas supply regulators as follows: Insert the nipple of the valve coupling into the tank valve and tighten the connection collar by turning it clockwise with one hand while holding the regulator with the other hand. (See diagram to right.)
5. Disconnect the propane cylinder from the regulator valve when the grill burner is not in use.
6. Always confirm all burner control knobs are in the OFF position before disconnecting the gas supply.
7. Before disconnecting, ensure that the tank valve is in the OFF position.
8. Always disconnect the gas supply regulators as follows: Loosen the connection collar by turning it counterclockwise with one hand while holding the regulator with the other hand and take the nipple of the valve out of the tank valve. (See diagram to right.) Do not obstruct the flow of combustion air and ventilation air to the grill. Keep ventilation openings of the cylinder enclosure free and clear from debris.
9. Place dust cap on cylinder valve outlet whenever the cylinder is not in use. Install only the type of dust cap on cylinder valve outlet that is provided with the cylinder valve. Other types of caps or plugs may result in leakage of propane.



! **DANGER**

To prevent fire or explosion hazard when testing for a leak:

1. Always perform the “leak test” as below before lighting the grill and each time the cylinder is connected for use.
2. Do not smoke or allow other sources of ignition in the area while conducting a leak test.
3. Conduct the leak test outdoors in a well-ventilated area.
4. Do not use matches, lighters or a flame to check for leaks.
5. Do not use grill until all leaks have been stopped. If you are unable to stop a leak, disconnect the propane supply, call for gas appliance service or your local propane gas supplier.

Checking for Leaks

1. Make 60–90 mL (2–3 oz) of testing solution by mixing one part of liquid dishwashing soap with three parts of water.
2. Make sure control knobs are in the “OFF” position.
3. Spray some solution on the regulator connection.
4. Inspect the solution at the connections for bubbles. If no bubbles appear, the connection is secure.
5. If bubbles appear, you have a leak. Go to step 6.
6. Disconnect the cylinder and reconnect. Make sure the connection is secured.
7. Retest with solution.
8. If you continue to see bubbles, replace the cylinder.

Lighting Grill Burners

! **DANGER**

Failure to open the lid while igniting the grill’s burners, or not waiting five minutes to allow gas to clear if the burner does not light, may result in an explosion that could cause serious bodily injury or death.

! **WARNING**

Never stand with your head directly above the grill when preparing to light the main burners, to prevent possible bodily injury.

Lighting Main Burner

! **WARNING**

Attempting to light the burner with the lid closed may cause an explosion. Make sure there are no obstructions of airflow to the gas unit. Spiders and insects can nest and clog the burner/venturi tube at the orifice. A clogged burner tube can lead to a fire beneath the appliance.

1. Read the instructions before lighting.
2. Open the lid when lighting.
3. Ensure burner controls are in the OFF position.
4. Turn on the gas at the tank valve.
5. Push and turn selected burner control to “HIGH” then push ignition button 2-3 times.
6. If ignition does not occur in 5 seconds, turn the burner control OFF, wait 5 minutes, then repeat the lighting procedure.
7. Release the burner control immediately once the burner is lit.

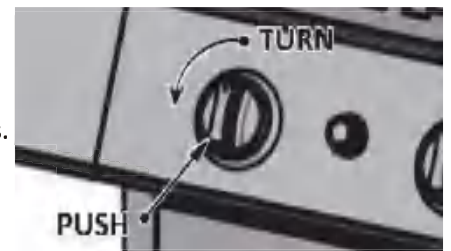

Using the Lighting Stick to Light the Main Burners

1. Insert a match into the end of lighting stick. Light the match.
2. Once lit, put the lighting stick through the hole on the barbecue body to reach the burner ports. (See diagram on the right.)
3. Press the valve knob and rotate it counterclockwise to the "HIGH" position. The burner should light immediately. If more than one burner is to be used, repeat the steps 2 and 3 until all burners are lit.
4. Adjust burners to the desired cooking temperature.

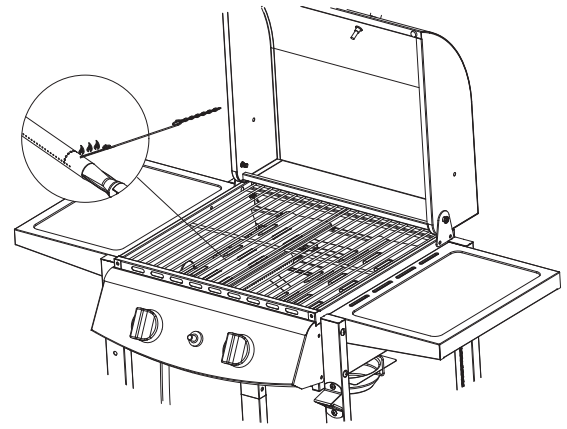

PRECAUTIONS :

1. After lighting, observe the burner flame. Make sure all burner ports are lit.
2. If the burner flame goes out during operation, immediately turn the gas "OFF". Open the lid to let the gas clear for at least 5 minutes before the next attempt.
3. Before cooking on the grill for the first time, operate the grill for approximately 15 minutes with the lid closed and the gas turned on "HIGH". This will "heat clean" the internal parts and dissipate odour from the manufacturing process and painted finish.
4. Clean the grill after each use. DO NOT use abrasive or flammable cleaners. These may damage parts of the grill and cause a fire.

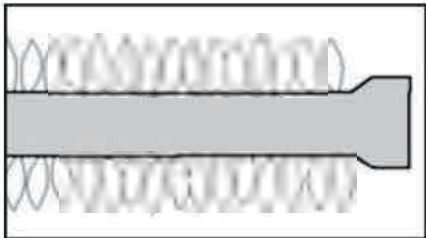

FIG. A
Normal: Soft blue flames with yellow tips between 2.5 - 5 cm (1 - 2 inches.)

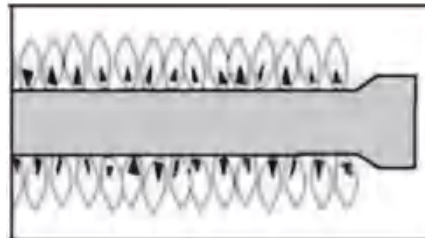

FIG. B
Out of adjustment:
Noisy hard blue flame, too much air.

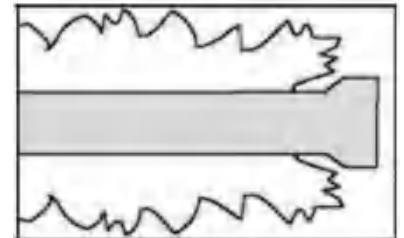
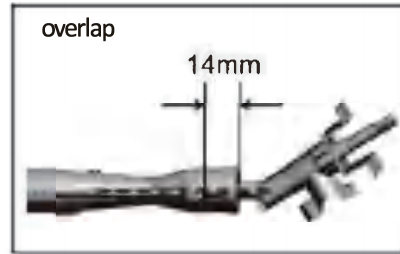

FIG. C
Poor combustion:
Wavy, yellow flames, too little air.

Burner installation



Hook should face upwards.



1. Overlap 14 mm between venturi tube and nozzle when assembling.
2. Keep the centre line of venturi tube and nozzle in alignment.

WARNING

Adjusting the air shutter while the grill is operating: If the grill is still hot, please wear protective gear and be careful. Failure to follow this instruction could cause personal injury.

Flare-Ups

“Flare-ups” sometimes occur when food drippings fall onto the heat distribution plate or burners and ignite. Some flaring is normal and desirable as it helps impart the unique flavours associated with grilled foods. Controlling the intensity of the flare-ups is necessary, however, in order to avoid burned or unevenly cooked foods and to prevent the possibility of accidental fire.

WARNING

Always monitor the grill closely when cooking and turn the flame level down to LOW or OFF if flare-ups intensify.

1. Always turn the valve knob(s) clockwise to the “HIGH” position, and then press and turn to “OFF”. Never force the knob without pressing it. This could damage the valve.
2. Promptly turn the gas supply to the “OFF” position at the propane cylinder.
3. Close the lid of the grill.

Excess Flow Safety Valve Reset Procedure

Regulators are equipped with a safety device that restricts the gas flow in the event of a gas leak. However, unsafe practices of grill operation could activate the safety device without having a gas leak.

- A sudden shut-off of the gas flow typically occurs if you open the liquid propane (LP) tank valve rapidly, or if one or more of the burner control knobs is in an open position when opening the LP tank valve.
- This procedure is effective with all sizes of LP tank.
- To ensure the procedure is safely and successfully performed, please carefully follow these instructions:
 1. Close the LP tank valve.
 2. Turn all burner control knobs to the OFF position.
 3. Disconnect the regulator from the LP tank.
 4. Open the lid of the grill.
 5. Turn burner control knobs to HIGH.
 6. Wait at least 1 minute.
 7. Turn burner control knobs OFF.
 8. Wait for at least 5 minutes.
 9. Reconnect the regulator to the LP tank.
 10. Slowly turn the LP tank valve $\frac{1}{4}$ at a time until the valve is fully open.
 11. With the lid open: For the grill with an ignition button: turn on only ONE front burner control knob to the HIGH position. Ignite the burner by pushing the ignition button. For grill with an automatic ignition: Push down the control knob you want to light, turn counterclockwise until you hear the ignition click.
 12. After the first front burner is lit, and turn on the other control knob(s) to the HIGH position. **If you have more than two burners, turn them on only ONE AT A TIME.
 13. When all front burners are lit, close the grill lid.
 14. Wait for 10 - 15 minutes; the temperature should reach 205–235°C (400 - 450°F).

! WARNING



CORRECT

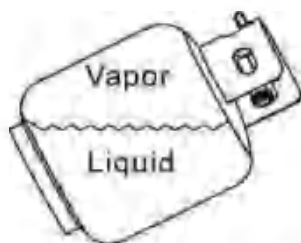

WRONG

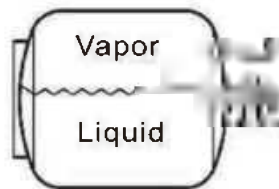

WRONG

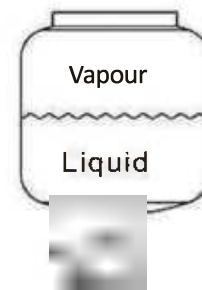

Care and Maintenance

IMPORTANT

Always allow grill to completely cool off before covering to prevent corrosion from condensation.

! CAUTION

Cleaning

Burning off the grill after every use (for about 15 minutes) will keep excessive food residue from building up. It is recommended that you clean the grill before and after use.

Recommended cleaning materials

Mild liquid dishwashing detergent	Hot water
Nylon cleaning pad	Stiff brush
Paper clip	Putty knife/scrapper
Compressed air	

DO NOT use cleaners that contain acid, mineral spirits or xylene.

Outside surfaces:

Use a mild dishwashing detergent and hot water solution to clean. Rinse thoroughly with water.

Inside surface:

If the inside surface of the grill lid has the appearance of peeling paint, baked-on grease has turned to carbon and is flaking off. Clean thoroughly with a strong solution of detergent and hot water. Rinse with water and allow it to completely dry.

Interior of grill bottom – Remove residue using brush, scraper and/or cleaning pad. Wash with a dishwashing detergent and hot water solution. Rinse with water and let dry.

Cooking Grates – The porcelain grates have a glass-like composition that should be handled with care. Use a mild dishwashing detergent or baking soda and hot water solution. Non-abrasive scouring powder can be used on stubborn stains. Rinse with water.

Heat Plates – Clean residue with stiff brush and wash with soapy water. Rinse with water.

Grease Cup – Periodically empty the grease cup and clean with a dishwashing detergent and hot water solution.

Cleaning the Burner Assembly

1. Turn gas off at the control knobs and propane tank.
2. Remove cooking grates and heat plate.
3. Remove grease cup.
4. Remove burner by unscrewing nut from beneath burner "foot" using a screwdriver and pliers.
5. Lift burner up and away from the gas valve orifice.
6. Clean inlet (venturi tube) of burner with small bottle brush or compressed air.
7. Remove all food residue and dirt on outside of burner surface.
8. Clean any clogged ports with a stiff wire (such as an opened paper clip).
9. Inspect burner for damage (cracks or holes). If damage is found, replace with a new burner. Make certain the gas valve orifices are correctly positioned, pointing straight into burner inlet (venturi tube). Also, check position of spark electrode.

TROUBLESHOOTING

Problems	Possible causes	Prevention/Cure
Burner doesn't light using knobs or igniter	Wires or electrode are covered by cooking residue	Clean wire or electrode using a cloth and rubbing alcohol
	Electrode and burners are wet	Wipe with dry cloth
	Ignition electrode cracked or broken; sparking where cracked	Replace electrode
Burner doesn't light using a match	No gas flow	Check if propane tank is empty. If not, refer to Excessive flow safety valve reset procedure.
	Coupling nut and regulator are not fully connected	Unscrew coupling nut about 1/2 to 3/4 turn counterclockwise to disengage, then restart threading the nut. Tighten by hand ONLY, do not use tools.
	Blockage of gas flow	Check burner tube and hose
	Disconnection of burner and valve	Reconnect
	Spider webs or insect nest in venturi	Clean venturi
Burner ports clogged or blocked	Clean burner ports	
Sudden drop in gas flow or reduced flame height	Out of gas	Replace cylinder
Irregular flame pattern, flame does not run the full length of burner	Burner ports are clogged or blocked	Clean burner ports
Flames turn yellow or orange	New burner may have residual manufacturing oils spider webs or insect nest in venturi	Burn grill for 15 minutes with the lid closed Clean venturi
	Food residue, grease or seasoning salt on burner	Clean burner
	Poor connection of valve to burner venturi	Assure burner venturi is properly connected with valve
	Flame blows out	High or gusting winds
Flame blows out	Low on propane gas	Replace cylinder
	Excess flow valve tripped	Refer to Excessive flow safety valve reset procedure

Flare-up	Grease build-up	Clean grill
	Excessive fat in meat	Trim fat from meat before grilling
	Excessive cooking temperature	Adjust (lower) temperature
Persistent grease fire	Grease trapped between burner and food on the grate	Turn knobs to OFF. Turn gas OFF at propane tank. Leave lid in closed position and let fire burn out. After grill cools, remove and clean all parts.
Flashback (fire in burner tubes)	Burners or tubes are blocked	Clean burners or tubes
Surface of inside lid appears to be peeling away	The lid is stainless steel and is not painted	Baked on grease build-up has turned to carbon and is flaking off. Clean thoroughly.
Irregular flame	Air flow is not correct. Correct flame is blue with yellow tips 2.5–5 cm (1"–2") high.	
	Too little air: wavy yellow or orange flames	If flames are yellow or orange – open flap at the end of the venturi tubes in 3 mm (1/8 in) increments until flames are correct
	Too much air: noisy blue flames	If flames are blue and noisy – close flap at the end of the venturi tubes in 3 mm (1/8 in) increments until flames are correct. *Propane models must be open a minimum of 3 mm (1/8 in).

Thank you for purchasing this product! If you have any questions about the product, such as missing parts, damaged products, product assembling, and operation, please contact us via **Amazon Message** or customer service number: **213-4467172 or 661-4358826**.

IMPORTANT

Please call our customer service department for any consulting:

213-4467172

661-4358826

(8:30am - 5:30pm P.S.T.)

DATED PROOF OF PURCHASE IS REQUIRED FOR WARRANTY SERVICE.

AVIS

Veillez appeler le service à la clientèle pour toutes questions au:

213-4467172

661-4358826

(8:30am - 5:30pm P.S.T.)

PREUVE D'ACHAT ORIGINALE REQUISE POUR SERVICE DE GARANTIE.

IMPORTANTE

Sólo hay que llamar nuestro departamento de servicio al cliente en caso de tener preguntas o inquietudes:

213-4467172

661-4358826

(8:30am - 5:30pm P.S.T.)

SE REQUIERE PRUEBA DE COMPRA CON FECHA PARA SERVICIO BAJO GARANTÍA.

Address: ROWAN ELECTRIC APPLIANCE LLC

28407 Ascent Way, Santa Clarita, CA 91350

Phone: 213-4467172 or 661-4358826