

---

# Assembly Instruction

## BAR STOOL

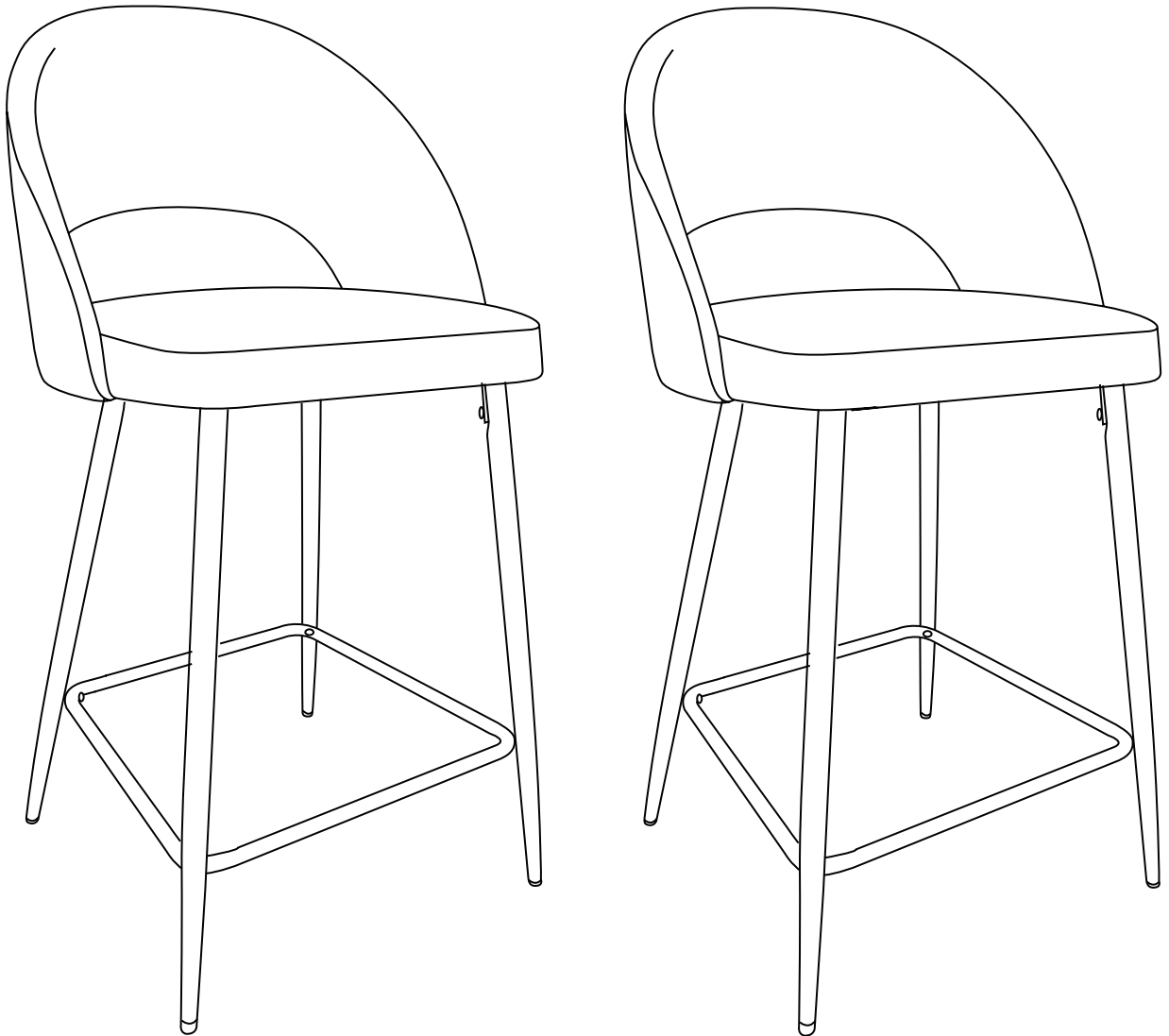

---

Carefully unpack and identify each component before beginning assembly. Before you begin, please refer to parts list to make sure that you have all parts. Please take care when assembling the unit and always place the parts on a clean, soft surface.

---



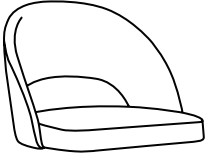
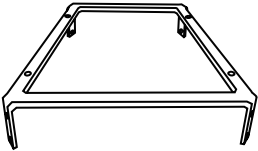
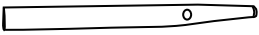
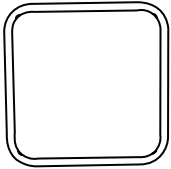

## PRE-ASSEMBLY PREPARATION

- **CARE AND CLEANING:** DO NOT scratch or chip the finish. DO NOT use abrasive chemicals for cleaning.
- **MAINTENANCE:** Check bolts/screws periodically and tighten them if necessary.
- **WARNING:** DO NOT USE if this product become damaged, and/or components are broken or missing.
- **REMINDER:** DO NOT fully tighten all bolts until assembly is completely finished.

### PARTS LIST

<p>SEAT (A)</p>  <p>Qty: 2</p>	<p>BOTTOM FRAME (B)</p>  <p>Qty: 2</p>	<p>LEG (C)</p>  <p>Qty: 8</p>	<p>FOOTREST (D)</p>  <p>Qty: 2</p>
---	---	---	---

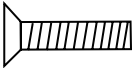
### HARDWARE LIST ( 1 set in a plastic bag)

<p>ALLEN BOLT (E)</p>  <p>M6x20MM</p> <p>Qty: 16</p>	<p>ALLEN BOLT (F)</p>  <p>M6x25MM</p> <p>Qty: 8</p>	<p>ALLEN BOLT (G)</p>  <p>M6x30MM</p> <p>Qty: 8</p>	<p>ALLEN WRENCH (H)</p>  <p>Qty: 2</p>
---	--	---	---

## STEP 1

Attach the Legs (C) to the Base Frame (B) by using Allen Bolts (E) and Allen Wrench (H). Please 80% tighten the bolts.

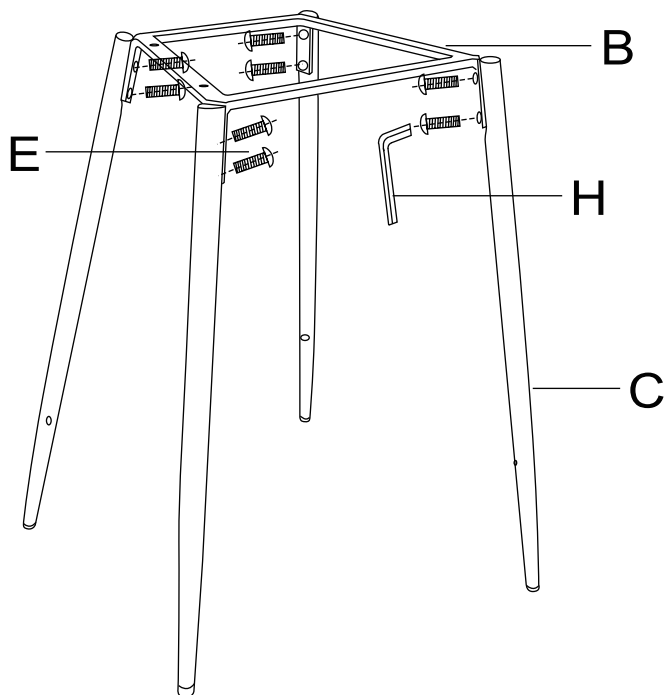

## STEP 2

Attach the Footrest (D) to the Legs (C) by using Allen Bolt (G) and Allen Wrench (H). Please 80% tighten the bolts.

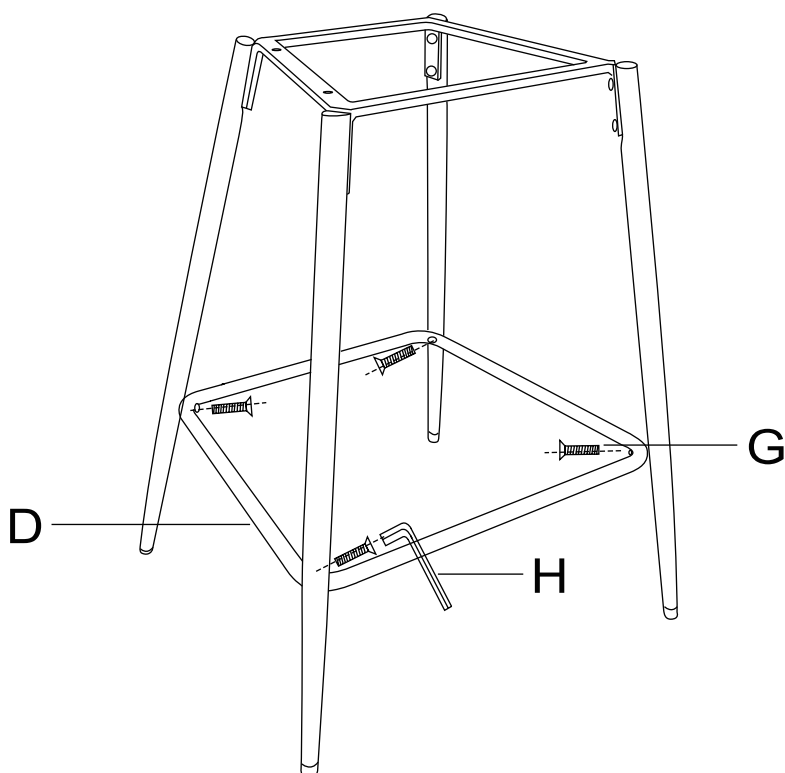

### STEP 3

Attach the Seat (A) to the Bottom Frame (B) by using Allen Bolt (F) and Allen Wrench(H). Please 80% tighten the bolts.

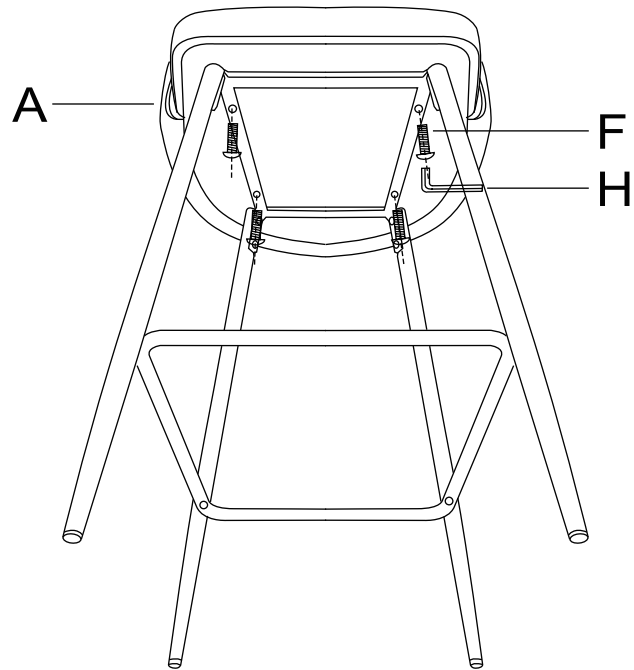

### STEP 4

Please make sure the chair legs are flat and all bolts are installed, then finally 100% tighten all bolts.

