

















ASSEMBLY INSTRUCTION

NO	PARTLIST	QTY
1	 HEADBOARD CUSHION	1PC
2	 LEFT HEADBOARD LEG (WITH "L" LABEL)	1PC
3	 RIGHT HEADBOARD LEG (WITH "R" LABEL)	1PC
4	 FOOTBOARD	1PC
5	 FOOTBOARD LEG	4PCS
6	 FOOTBOARD SUPPORT	1PC
7	 BED RAIL	2PCS
8	 BED SLAT <small>3PCS</small>	1 SET
9	 BED SLAT SUPPORT	1PC
10	 BED SLAT SUPPORT LEG (with adjustable feet)	3PCS

ITEM	HARDWARE	QTY
A	 JCBB SCREW M8 x 20mm	8PCS
B	 JCBC SCREW M6 x 50mm	13PCS
C	 SPRING WASHER	6PCS
D	 FLAT WASHER	6PCS
E	 SCREW M4 x 32mm	6PCS
F	 SMALL ALLEN WRENCH M4 x 100mm	1PC
G	 BIG ALLEN WRENCH M5 x 65mm	1PC

ALL PARTS AND PIECES ARE LOCATED INSIDE THE HEADBOARD AND FOOTBOARD.

STEP 1

Begin assembly by attaching each Headboard Leg (2) & (3) to the bottom of the Headboard Cushion (1) by aligning the hole and securing with 3 Allen Bolts (B), 3 Spring Washer (C), 3 Flat Washer (D) per leg using L-Key (F).

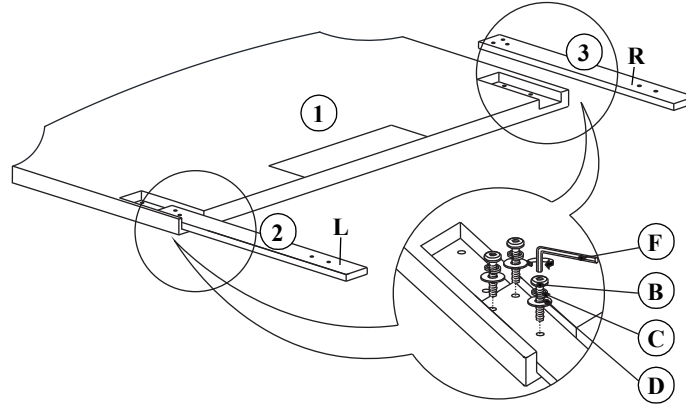

STEP 2

Attach each Footboard Leg (5) to the bottom of Footboard (4) securing with 1 Allen Bolt (B) per leg using L-Key (F). After that secure 1 piece of Footboard Support (6) to the Footboard (4). Tighten the Footboard Support (6) clockwise until secure.

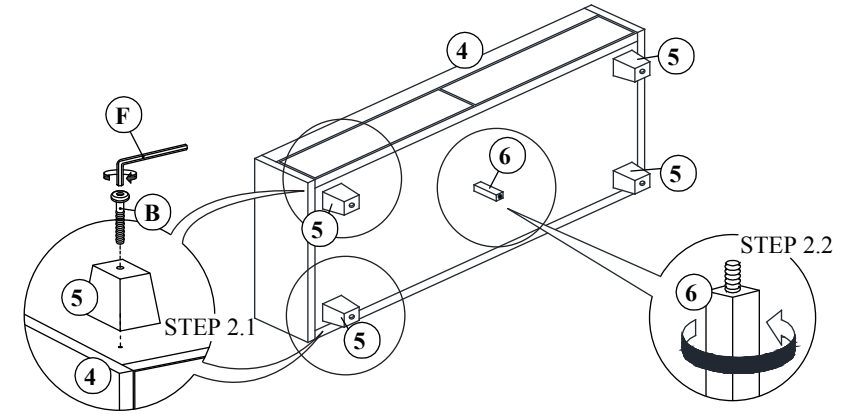

STEP 3

Attach Bed Rail (7) to the Headboard Leg (2) & (3) and Footboard (4). Aligning holes and securing with 2 Allen Bolts (A) per each by using L-Key (G). (DO NOT FULLY TIGHTEN BOLTS FOR THIS STEP.)

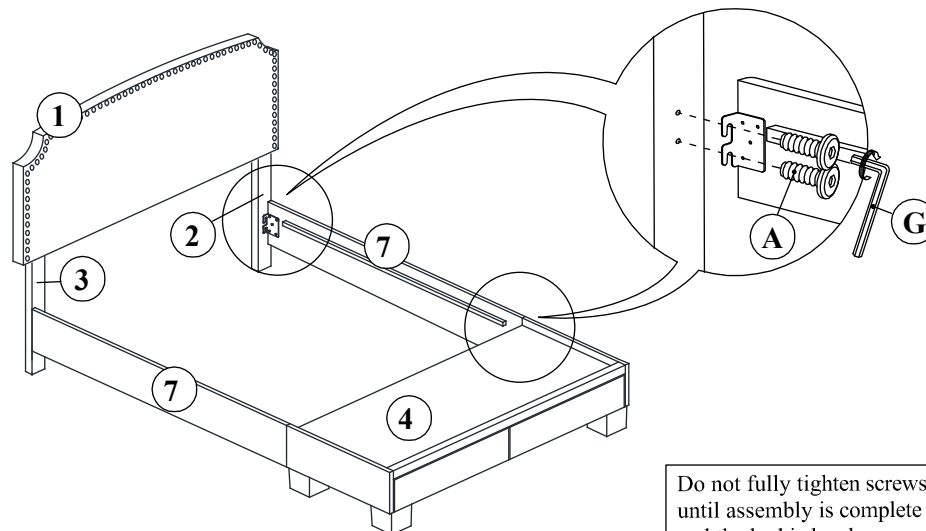

Do not fully tighten screws until assembly is complete and the bed is level.

ASSEMBLY INSTRUCTION

STEP 4

Attach Bed Slat (8) to the Bed Slat Support (9) and Bed Slat Support Leg (10) using 1 Allen Bolt (B) per each end. Tighten bolts using L-Key (F) provided.

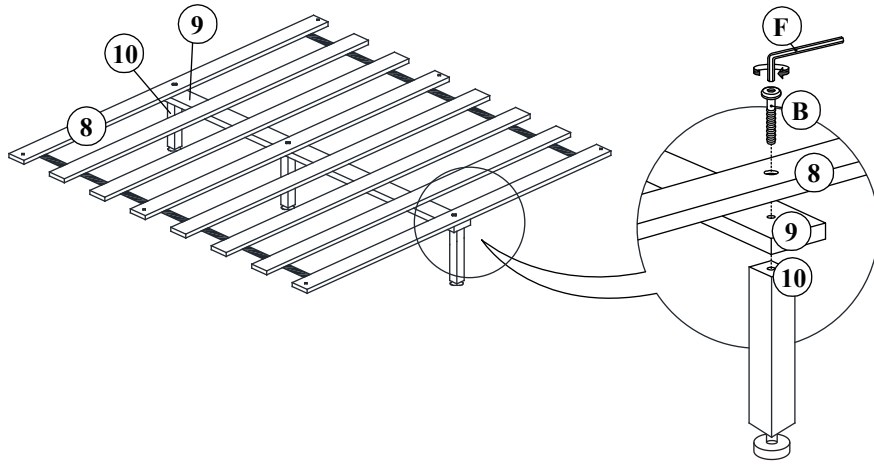

STEP 5

Insert Bed Slat (8) in between Bed Rail. Secure Bed Slat (8) with 6 Screw (E). Tighten screws with Philips screwdriver (not included).

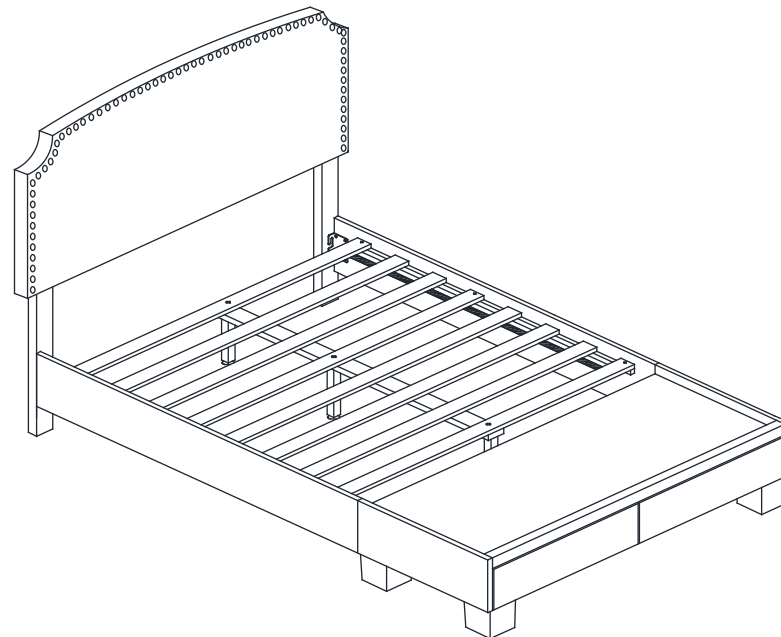
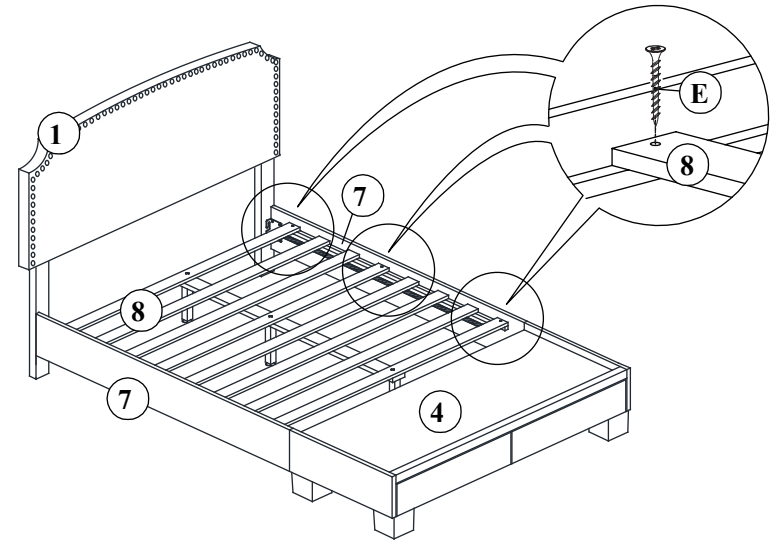

**ASSEMBLY
COMPLETED**