

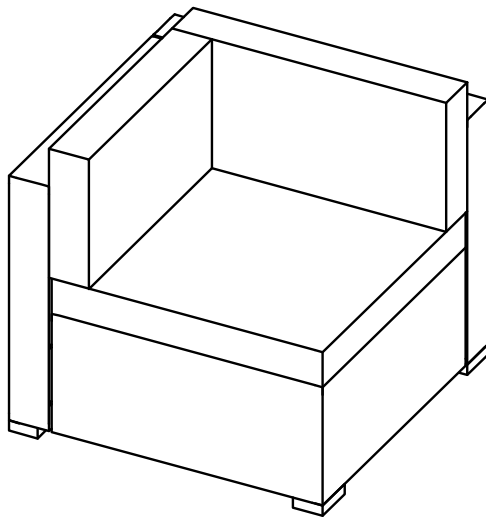

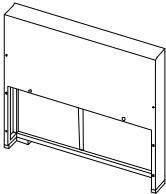

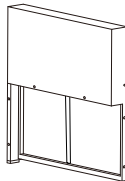

Outdoor Wicker Corner Chair

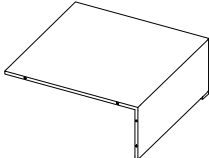
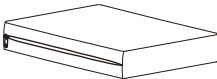





PART LIST

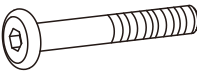

				
<p>Arm Panel 1 PC</p>	<p>Back Panel 1 PC</p>	<p>Seat Panel 1 PC</p>	<p>Cover of Seat Cushion * 1 PC</p>	<p>Core of Seat Cushion 1 PC</p>
				
<p>Cover of Back Cushion * 1 PC</p>	<p>Core of Back Cushion 1 PC</p>	<p>Cover of Side Cushion * 1 PC</p>	<p>Core of Side Cushion 1 PC</p>	

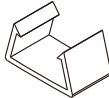
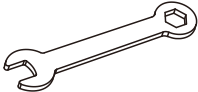
*Please note cushion covers will ship separately.

HARDWARE LIST

 <p>M6*50mm</p>	 <p>M6mm</p>	 <p>D18mm</p>		 <p>M6mm</p>
<p>Bolt 11 PCS</p>	<p>Nut 11 PCS</p>	<p>Washer 22 PCS</p>	<p>Plastic Clip 2 PCS</p>	<p>Wrench 1 PC</p>
 <p>M6mm</p>				
<p>Allen Key 1 PC</p>				

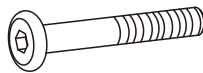
EXTRA HARDWARE LIST

 <p>M6*50mm</p>	 <p>M6mm</p>	 <p>D18mm</p>
<p>Bolt 1 PC</p>	<p>Nut 1 PC</p>	<p>Washer 1 PC</p>

Step 1. Lay back panel (part B) down on a soft flat surface, such as carpet, as shown below. Attach arm panel (part A) to back panel (part B) using bolts (part #1), washers (part #3) nuts (part #2), wrench (part #5) and allen key (part #6).

NOTE: Please do not fully tighten bolts until unit is fully assembled.

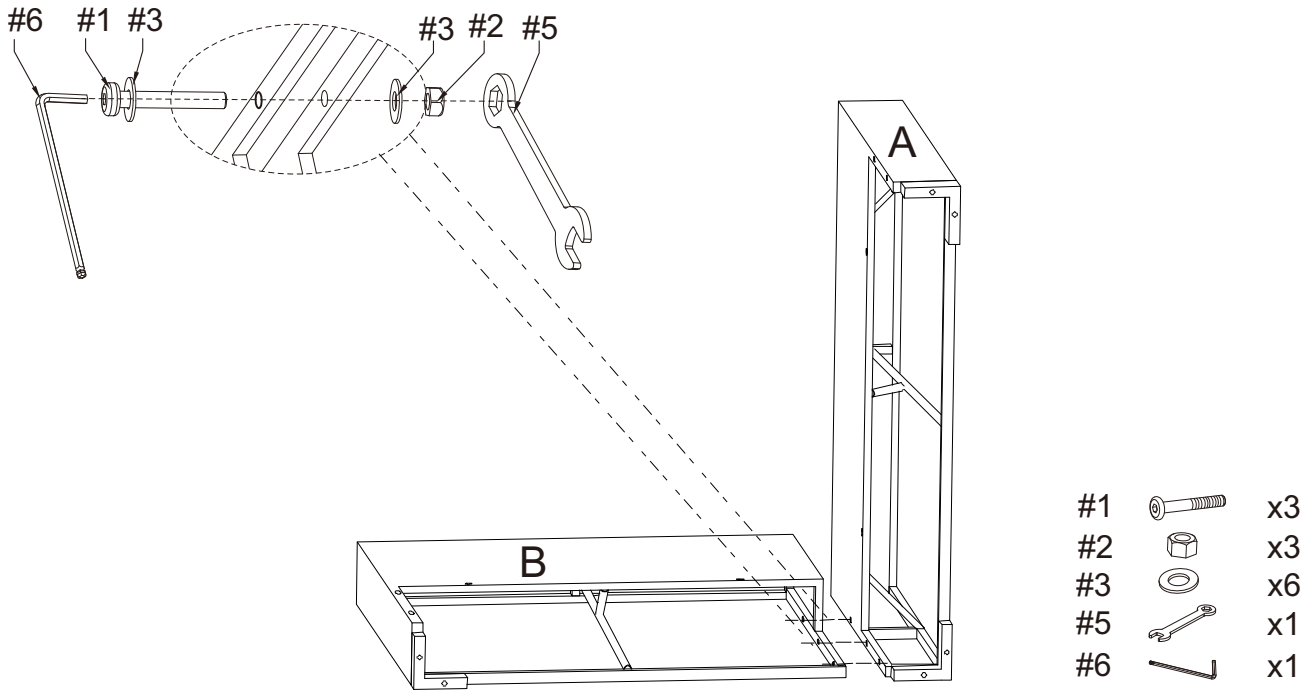

Step 2. Attach seat panel (part C) to assembled unit (parts A&B) using bolts (part #1), washers (part #3), nuts (part #2), wrench (part #5) and allen key (part #6).

NOTE: Please fully tighten all bolts at this time.

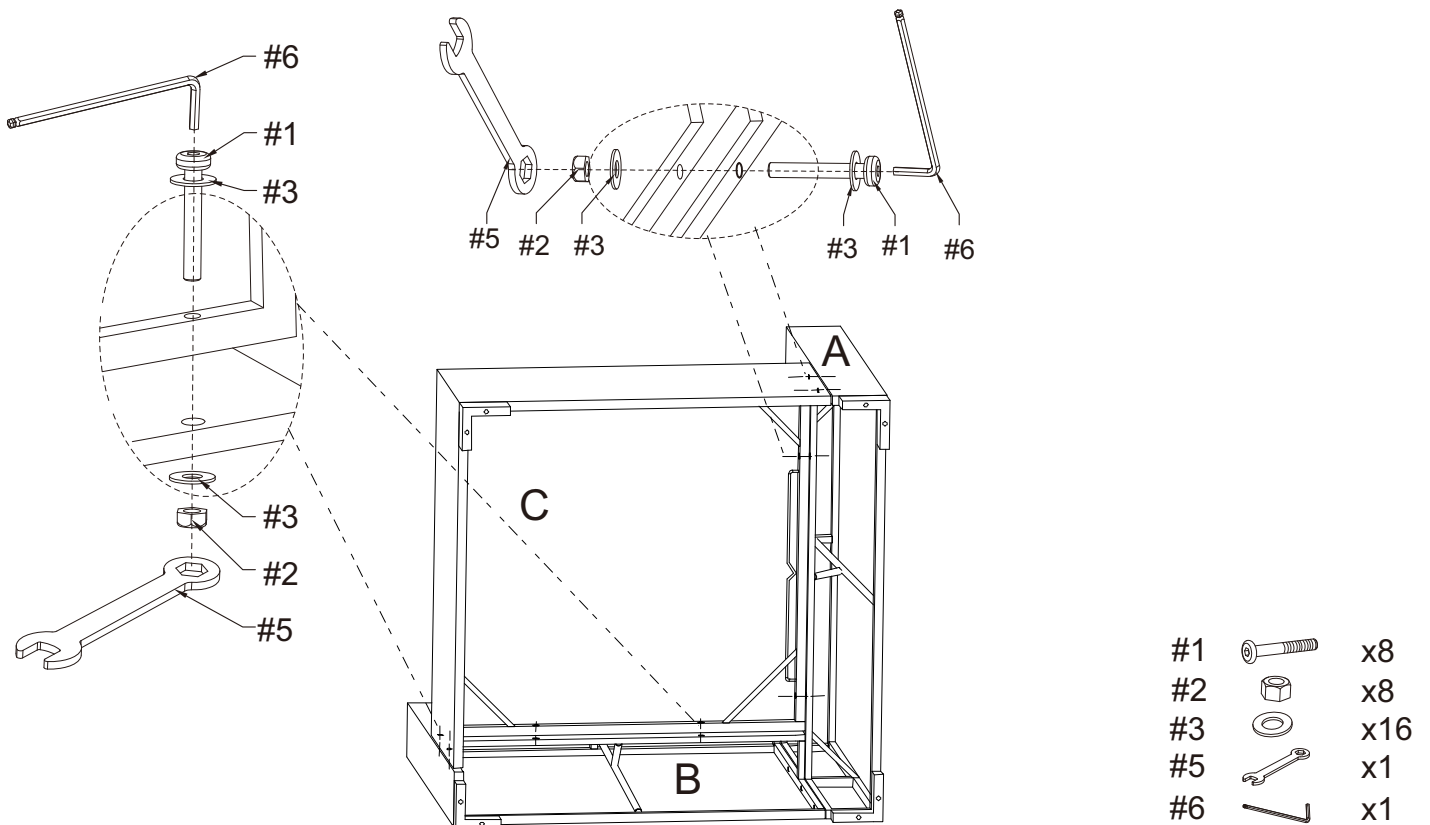

Step 3. Insert core of seat cushion (part E) into cover of seat cushion (part D).
Insert core of back cushion (part G) into cover of back cushion (part F).
Insert core of side cushion (part I) into cover of side cushion (part H).

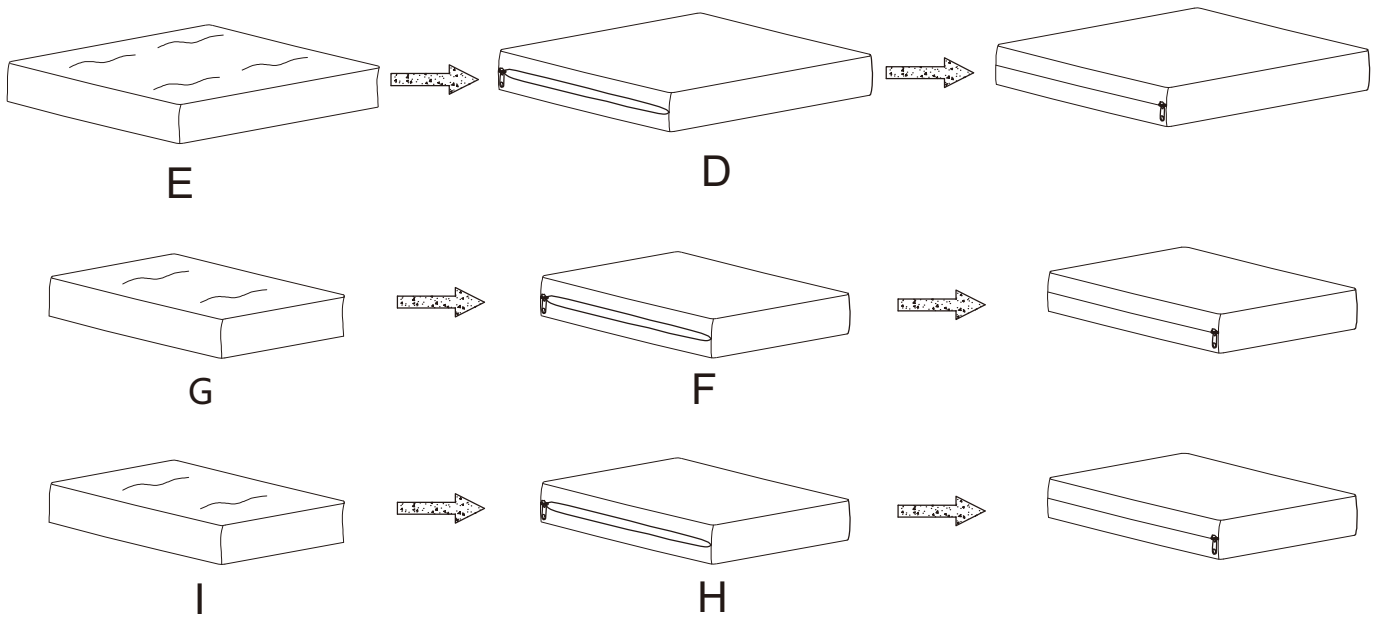

Step 4. Carefully turn the assembled chair upright and add cushions as shown below.

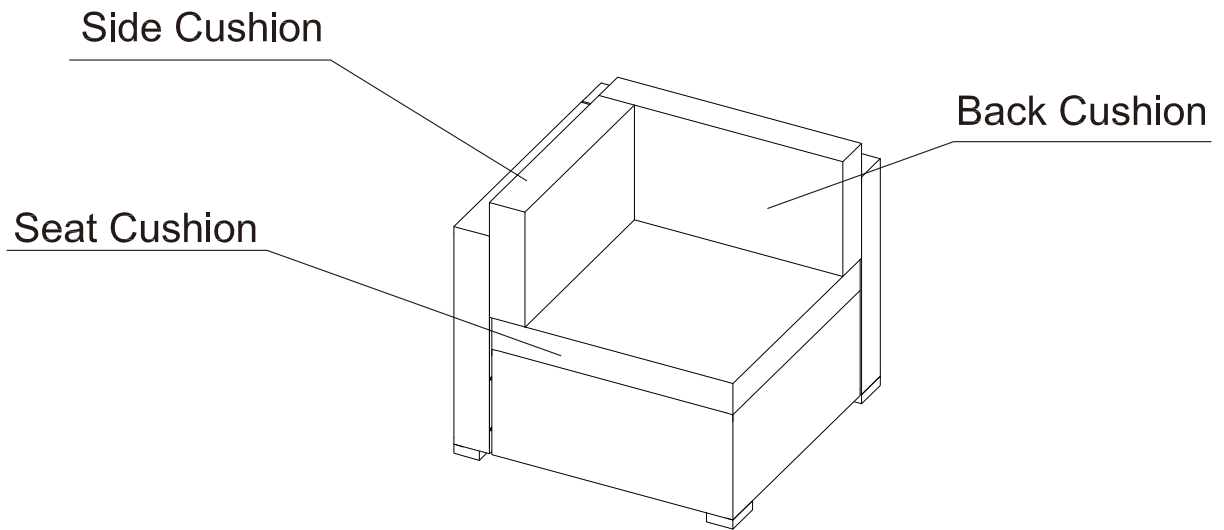

Step 6. Use plastic clips (part #4) to secure additional units together as shown.

