

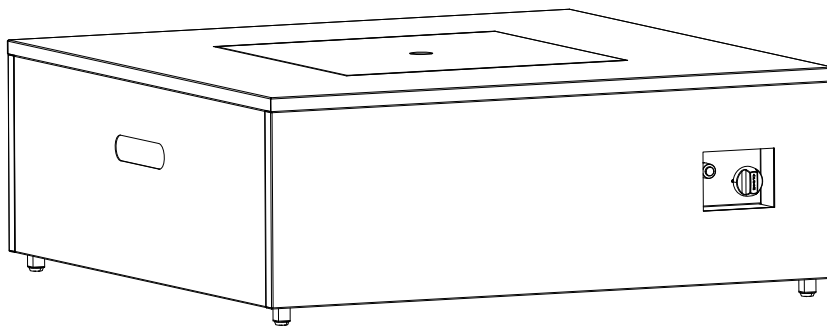

Outdoor Fire Pit Instruction and Owners Manual

Item # : FP10430 / FP10431

Model # : 24-8202W



WARNING **FOR YOUR SAFETY**

1. Improper installation, adjustment, alteration, service or maintenance can cause injury or property damage.
2. Read the installation, operation, and Maintenance instructions thoroughly before installing or servicing this equipment.
3. Failure to follow these instructions could result in fire or explosion, which could cause property damage, personal injury, or death.

WARNING

For Outdoor Use Only

WARNING

This product can expose you to chemicals including carbon monoxide which is known to the State of California to cause birth defects or other reproductive harm. For more information go to www.P65Warnings.ca.gov.



Electronic ignition.
Requires (1) AA.
(Not Included)



ATTACH YOUR RECEIPT HERE

Keep a copy of your proof of purchase or order confirmation which will be needed if you need to contact us about warranty coverage.

Purchase Date: _____



Questions, problems, missing parts?

Before returning to your retailer, contact our exceptional customer service.

Contact us by email at customer care@jrhome.com or call us toll-free at (800) 561-5550, 7:30 a.m. – 4:00 p.m., PST, Monday – Friday .

TABLE OF CONTENTS

Table of Contents/Before You Begin	Page 2
Package Contents	Page 3
Safety Information	Page 4
Assembly	Page 5-8
Care and Maintenance	Page 9
Warranty Information	Page 10-11



BEFORE YOU BEGIN

Please read and understand this entire manual before attempting to assemble, operate or install this appliance.

This manual contains important information about the assembly, operation and maintenance of this appliance. General safety information is presented in the first few pages and is located throughout this manual. Keep this manual for future reference and to educate new users of this appliance.

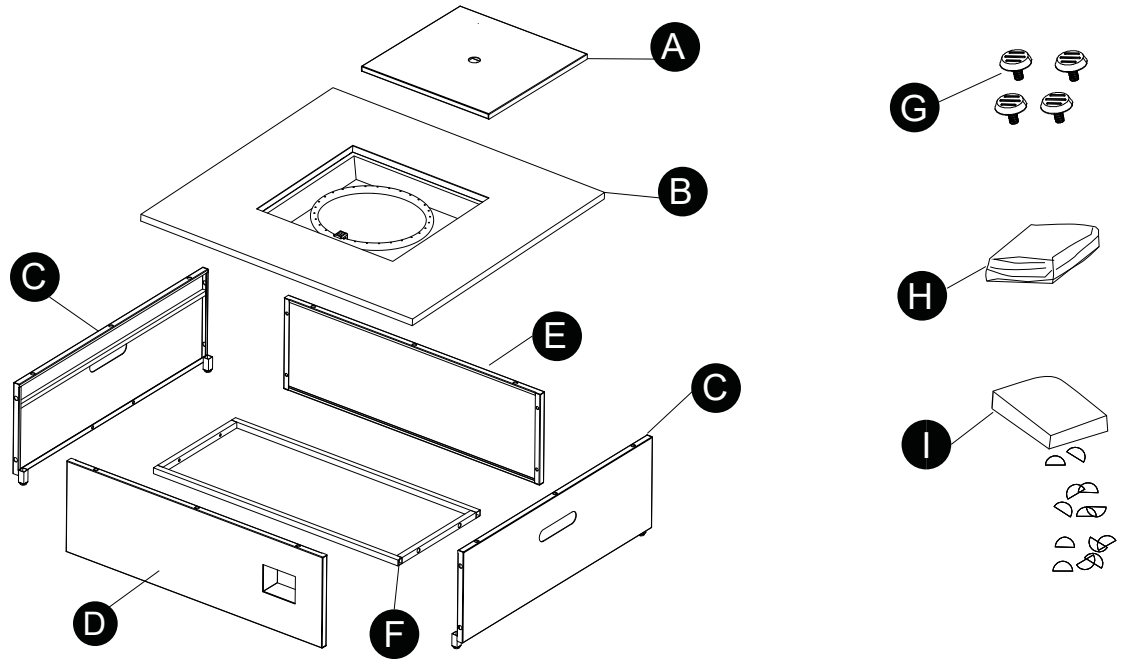

PART	DESCRIPTION	QUANTITY
A	Removable Burner Cover	1
B	Table Top	1
C	Side Panel	2
D	Front Panel	1
E	Back Panel	1
F	Fixed Rod	1
G	Adjustable Foot	4
H	Protective Cover	1
I	Fire Glass	1 box



HARDWARE CONTENTS

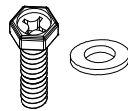

J

Bolt(1/4x35mm)
Washer
Qty.4

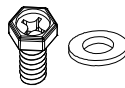

K

Bolt(1/4x12mm)
Washer
Qty.24



L

Wrench
Qty.1

SAFETY INFORMATION

This appliance has been tested to and complies with the ANS Z 21.97-2010, Outdoor Decorative Gas Appliances CGA CR 97-003 Outdoor Gas Fireplaces. The installation must conform to local codes or in the absence of local codes to the National Fuel Gas Code, ANS Z223.1. This manual contains important information about the assembly, operation and maintenance of this appliance. General safety information is presented in these first few pages and is also located throughout the manual. Keep this manual for future reference and to educate new users of this product. This manual should be read in conjunction with the labeling on the product. Safety precautions are essential when any mechanical or gas fueled equipment is involved. These precautions are necessary when using, storing, and servicing. Using the equipment with the respect and caution demanded will reduce the possibilities of personal injury or property damage. The following symbols shown below are used extensively throughout this manual. Always heed these precautions, as they are essential when using any mechanical or gas fueled equipment.

WARNING

Failure to comply with the precautions and instructions provided with this appliance can result in death, serious bodily injury and property loss or damage from hazards of fire, explosion, burn, asphyxiation, and of carbon monoxide poisoning. Only persons who can understand and follow the instructions should use or service this appliance.

WARNING / DANGER

WARNING/DANGER indicates an imminently hazardous situation which, if not avoided, will result in death or serious injury.

WARNING

Do not store or use gasoline or other flammable vapors and liquids in the vicinity of this or any other appliance. An LP-cylinder not connected for use shall not be stored in the vicinity of this or any other appliance.

DANGER

EXPLOSION—FIRE HAZARD

- Keep solid combustibles, such as building materials, paper, or cardboard a safe distance away from the appliance as recommended by the instructions.
- Provide adequate clearances around air openings into the combustion chamber.
- Never use the appliance in spaces which do or may contain volatile or airborne combustibles, or products such as gasoline, solvents, paint thinner, dust particles, or unknown chemicals.
- During operation, this appliance can be a source of ignition. Keep appliance area clear and free from combustible materials, gasoline, paint thinner, cleaning solvents and other flammable vapors and liquids. Do not use the appliance in areas with high dust content. Minimum appliance clearances from combustible materials: 2 feet (24 inches) from the sides & 2 feet (24 inches) from the rear, 6 feet (72 inches) from ceiling.
- Never store propane near high heat, open flames, pilot lights, direct sunlight, other ignition sources or where temperatures exceed 120 degrees F (49 degrees C).
- Propane vapors are heavier than air and can accumulate in low places. If you smell gas, leave the area immediately.
- Never install or remove a propane cylinder while the appliance is lighted, near flame, pilot lights, or other ignition sources or while the appliance is hot to the touch. This appliance is red hot during use and can ignite flammables too close to the burner. Keep flammables at least 2 feet (24 inches) from top and 2 feet (24 inches) from sides. Keep gasoline and other flammable liquids and vapors well away from the appliance.
- Store the propane cylinder outdoors in a well ventilated space out of the reach of children. Never store the propane cylinder in an enclosed area (house, garage, etc.). If the appliance is to be stored indoors, disconnect the propane cylinder for outdoor storage.

WARNING

Improper installation, adjustment, alteration, service or maintenance can cause property damage, injury or death. Read the installation, operation and maintenance instructions thoroughly before installing or servicing this equipment.

DANGER

FOR YOUR SAFETY

If you smell gas:

1. Shut off gas to the appliance.
2. Extinguish any open flame.
3. If odor continues, keep away from the appliance and immediately call your gas supplier or fire department.

WARNING

We cannot foresee every use which may be made of our appliance. Check with your local fire safety authority if you have questions about your appliance use. Other standards govern the use of fuel gases and heat producing products for specific uses. Your local authorities can advise you about these. If no local codes exist, follow National Fuel Gas Code, ANS Z223.1. In Canada, installation must conform to local codes. If no local codes exist, follow the current National standards of CANADA CAN/CGA-B 149.2.

WARNING: FOR OUTDOOR USE ONLY

CARBON MONOXIDE HAZARD

This appliance is a combustion appliance. All combustion appliances produce carbon monoxide (CO) during the combustion process. This product is designed to produce extremely minute, non-hazardous amounts of CO if used and maintained in accordance with all warnings and instructions. Do not block air flow into or out of the appliance.

- Carbon Monoxide (CO) poisoning produces flu-like symptoms, watery eyes, headaches, dizziness, fatigue and possibly death. You can't see it and you can't smell it. It's an invisible killer. If these symptoms are present during operation of this product get fresh air immediately!
- For outdoor use only.
- Never use inside house, or other unventilated or enclosed area.
- This appliance consumes air (oxygen) Do not use in unventilated or enclosed areas to avoid endangering your life.



PREPARATION

Before beginning assembly, be sure to empty contents of carton and make sure all parts are present. If any parts are missing, please contact Customer Service at customer care@jrhome.com or (800)-561-5550, Monday-Friday, 7:30 a.m. – 4:00 p.m. PST.

Place all parts on a soft, level surface for assembly.

Estimated Assembly Time: 30 Minutes | DO NOT over tighten hardware!

- 1 Install the adjustable feet (G) on the side panel (C) and repeat the installation of two side panels.

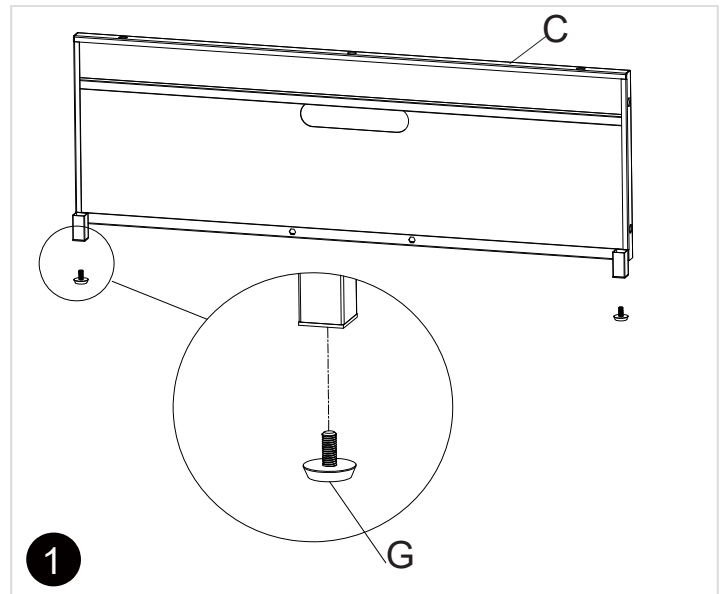

- 2 Secure the table top (B) and front panel (D) with bolts and washers (K), and secure control panel with bolts and washers (K).

Hardware Used:

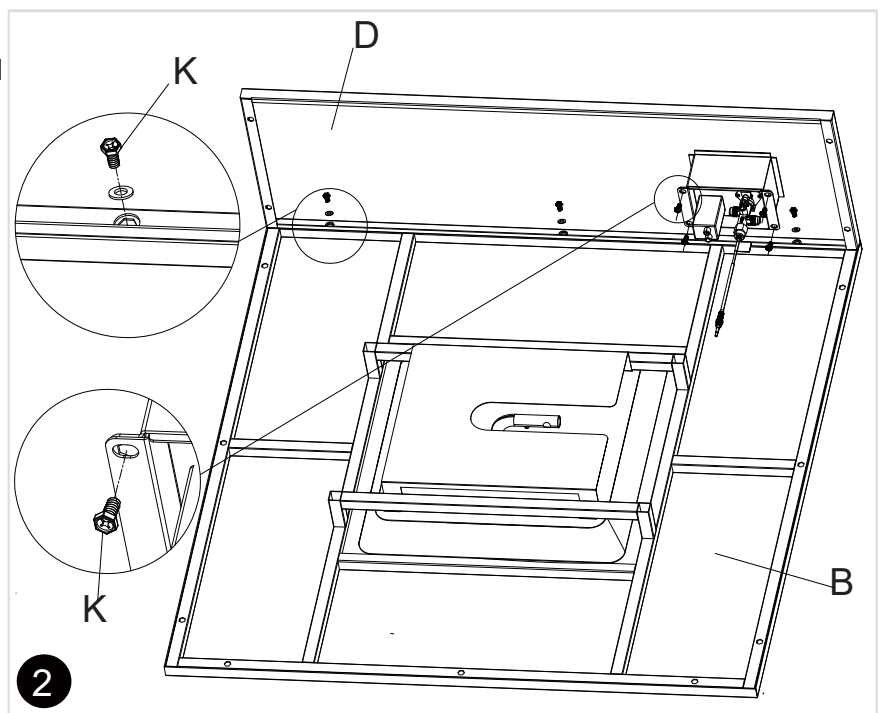
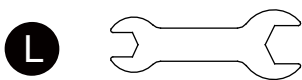
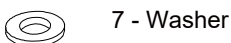
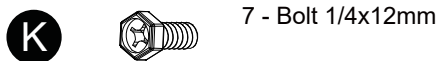

3 Attach the back panel (E) to the table top with bolts and washers (K).

Hardware Used:

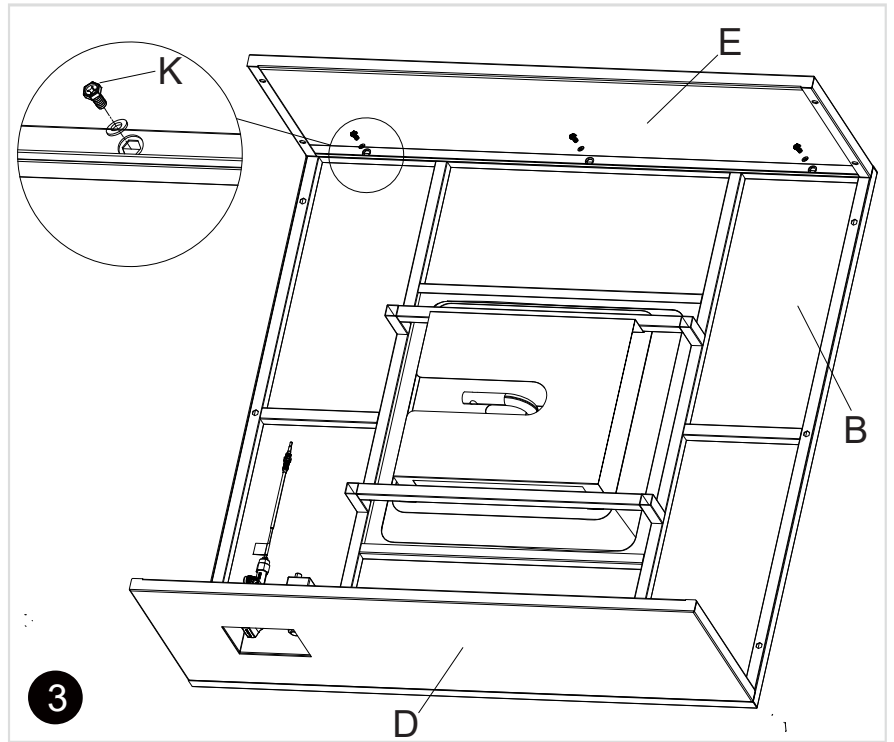
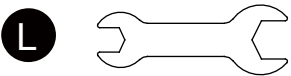
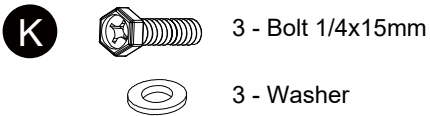

4 Attach two pieces of side panels (C) to the table top (B) with bolts and washers (K).

Hardware Used:

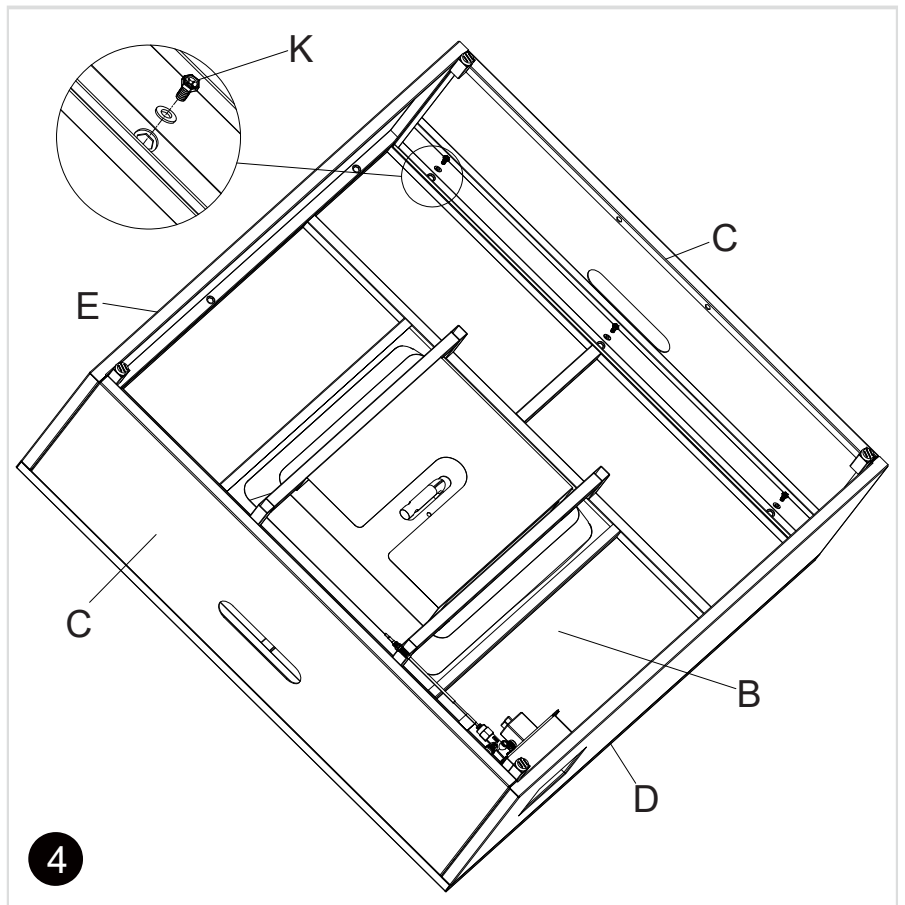
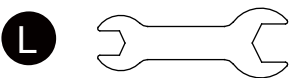
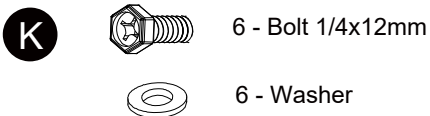

5 Attach the fixed rod (F) to the front panel and back panel with bolts and washers (J).

Hardware Used:

J  4 - Bolt 1/4x35mm

 4 - Washer

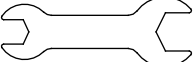
L 

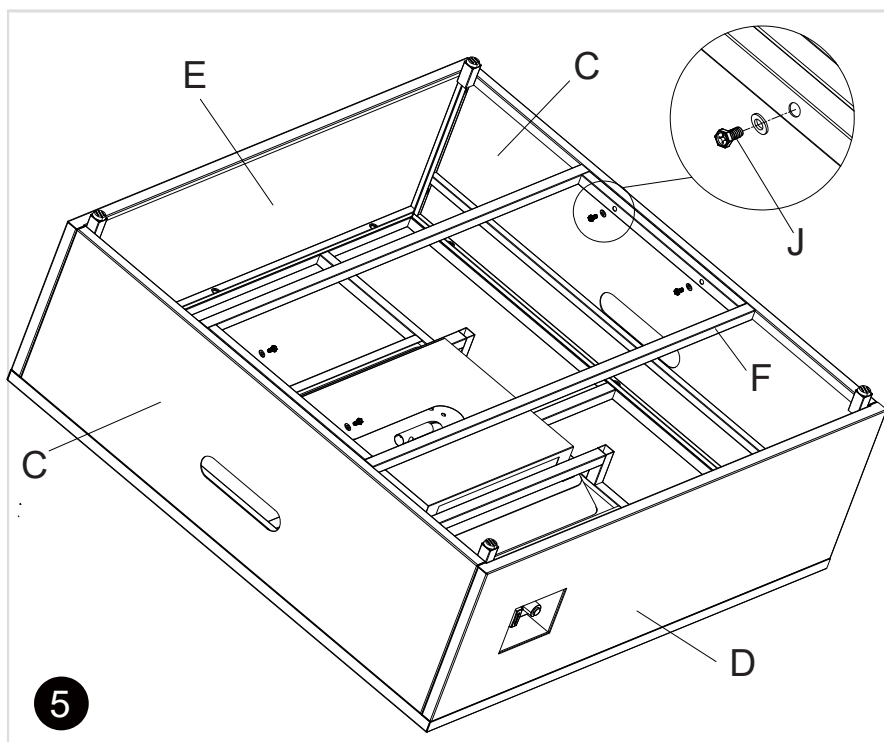

6 Secure the two side panels (C) with bolts and washers (K). Tighten all bolts.

Hardware Used:

K  8 - Bolt 1/4x12mm

 8 - Washer

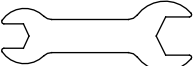
L 

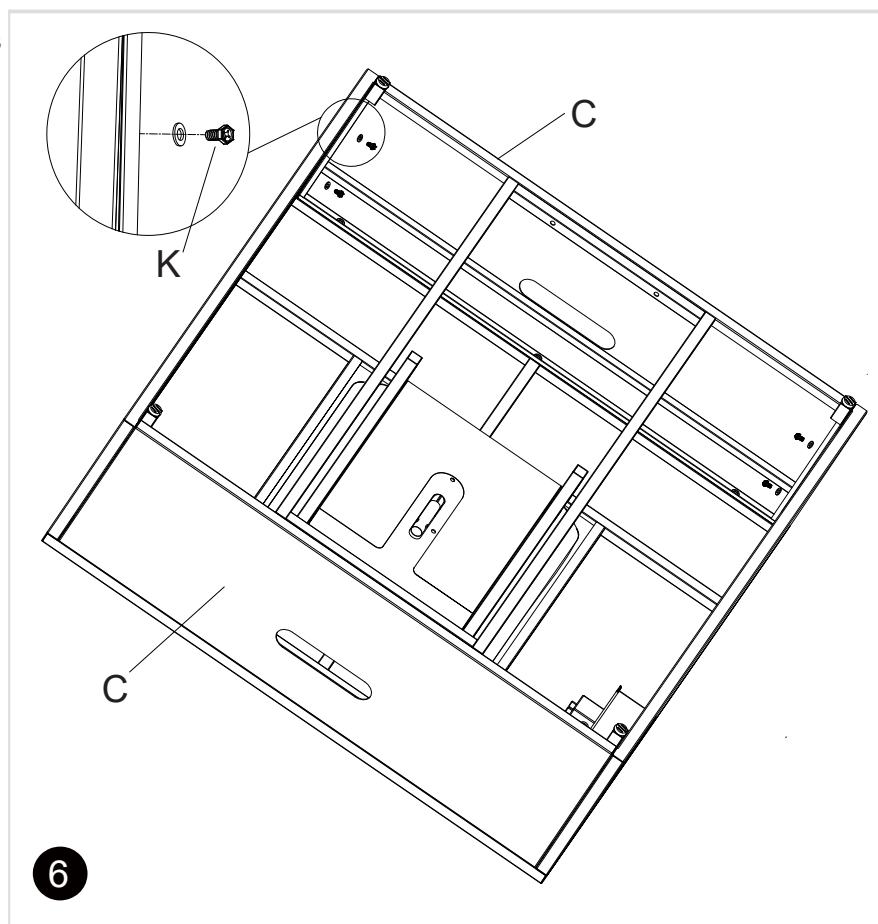

7 Put the Fire Glass (I) around the Burner.

Put the Removable Burner Cover (A) on the burner when the fire pit is NOT in use or after use.

Cover it with the Protective Cover (H) when the fire pit has cooled COMPLETELY.

DO NOT PUT THE PROTECTIVE FIRE PIT COVER ON A HOT FIRE PIT.

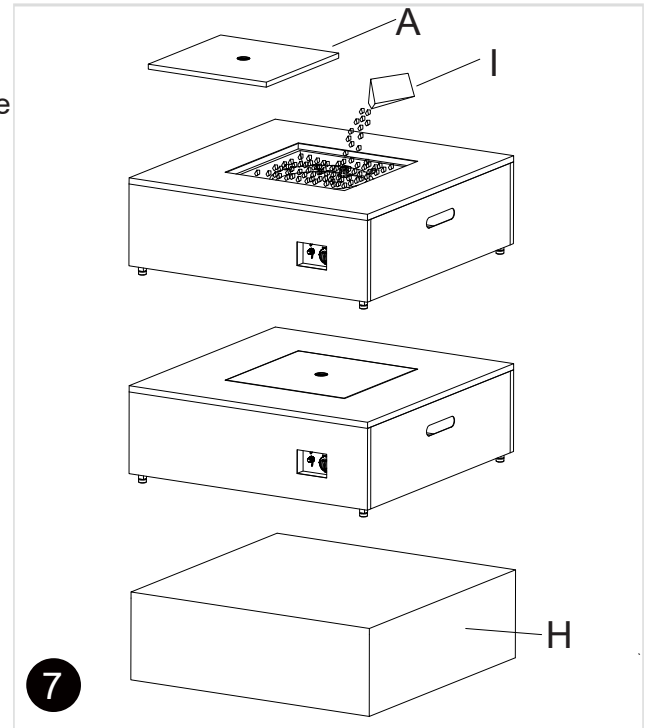

8 Connect hose and regulator to cylinder. The propane gas and cylinder are sold separately. Use a standard 20lb propane cylinder only. Use this appliance only with a propane vapor withdrawal supply system. See chapter 5 of the standard storage and handling of liquefied petroleum gas, ANS/NFPA 58. Your local library or fire department should have this book.

Storage of an appliance indoors is permissible only if the cylinder is disconnected and removed from the appliance. A cylinder must be stored outdoors in a well-ventilated area out of the reach of children. A disconnected cylinder must have dust caps tightly installed and must not be stored in a building, garage or any other enclosed area. The maximum inlet gas supply pressure: 250 psi, the minimum inlet gas supply pressure: 5 psi.

The minimum hourly of 10,000 BTU is required input rating for a appliance for automatic operation at ratings less than full input rating. The pressure regulator and hose assembly supplied with the appliance must be used.

The installation must conform with local codes, or in the absence of local codes, with national fuel gas code, ANS Z223.1/NFPA54, natural gas and propane Installation Code, CSA B 149.1, or propane storage and handling code, B149.2.

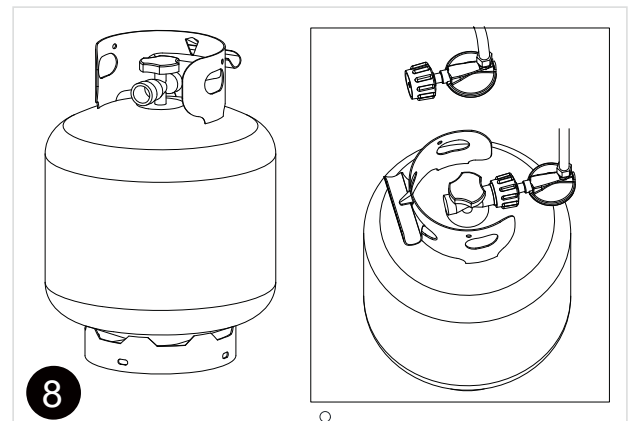

To enjoy years of outstanding performance from your fire pit, make sure you perform the following maintenance activities on a regular basis:

1. Use warm soapy water for cleaning. Never use flammable or corrosive cleaning agents.
2. While cleaning your unit, be sure to keep the area around the burner and control compartment dry at all times. Do not submerge the control valve assembly. If the gas control is submerged in water, do NOT use it. It must be replaced. Make sure fire pit has cooled completely before cleaning or covering with a cover.
 - A. Keep the appliance area clear and free from combustible materials, gasoline and other flammable vapors and liquids.
 - B. Do not obstruct the flow of combustion and ventilation air.
 - C. Keep the ventilation opening(s) of the cylinder enclosure free and clear from debris.
3. Air flow must be unobstructed. Keep controls, burner, and circulating air passageways clean. Signs of possible blockage include:
 - Gas odor with extreme yellow tipping of flame.
 - Fire pit does NOT reach the desired temperature.
 - Fire pit glow is excessively uneven.
 - Fire pit makes popping noise.
 - Spiders and insects can nest in burner or orifices. This dangerous condition can damage fire pit and render it unsafe for use. Clean burner holes by using a heavy-duty pipe cleaner. Compressed air may help clear away smaller particles.
 - Carbon deposits may create a fire hazard. Clean burner screen with warm soapy water if any carbon deposits develop.



Note: In a salt-air environment (such as near an ocean), corrosion occurs more quickly than normal. Frequently check for corroded areas and repair them promptly.

SERVICE:

Only a qualified service person should repair gas passages and associated components.

••••• *Always allow fire pit to cool before attempting service.*

WARNING

FOR YOUR SAFETY

- Do NOT touch or move fire pit for at least 45 minutes after use.
- Burner is hot to the touch.
- Allow burner to cool before touching.

STORAGE:

Between uses:

- Turn control knob OFF.
- Disconnect LP source.
- Store fire pit in an area sheltered from direct contact with inclement weather (such as rain, sleet, hail, snow, dust and debris).
- If desired, cover fire pit to protect exterior surfaces and to help prevent build-up in air passages.

During periods of extended inactivity or when transporting:

- Turn control knob OFF.
- Disconnect LP source and move to a secure, well-ventilated location outdoors.
- Store fire pit in an area sheltered from direct contact with inclement weather (such as rain, sleet, hail, snow dust and debris).
- If desired, cover fire pit to protect exterior surfaces and to help prevent build-up in air passages. Never leave LP cylinder exposed to direct sunlight or excessive heat.

Note: Wait until fire pit is cool before covering.

Extend Your Warranty By Leaving A Review

We want your opinion about your purchase...and we want you to tell everyone about it!

Just leave a review for the product on the retailers website where you made your purchase, or at www.jrhome.com, and fill in the online warranty at www.jrhome.com/warranty-registration within 30 days of purchase to receive a complimentary extra year of warranty protection.

*Follow us on:
Suivez-nous sur*



YouTube



www.jrhome.com #jrhome #paramount

IMPORTANT

For questions, concerns or problems with our product please email our customer service department:

customercare@jrhome.com

DATED PROOF OF PURCHASE REQUIRED FOR WARRANTY SERVICE

Si vous éprouvez des difficultés ou si vous avez des questions ou des préoccupations, prière de faire parvenir un courriel à notre service à la clientèle

customercare@jrhome.com

UNE PREUVE D'ACHAT DATÉE EST REQUISE POUR SE PRÉVALOIR DE LA GARANTIE.

WARRANTY

This product is inspected, tested and carefully packaged to minimize the chance of damage during shipment. If a part (excluding light bulbs, glass and fuses*) within one year from the date of purchase proves to be defective in material or fabrication under normal use, the part will be repaired or replaced. The Company's obligation under the warranty is to replace or repair defective parts at our discretion. Any expenses or damage resulting from the installation, removal or transportation of the product will be the responsibility of the owner and are not covered by this warranty. The owner assumes all other risks arising from the use or misuse of the product. The warranty will be void if the product damage or failure is deemed by the Company to be caused by accident, alteration, misuse, abuse, incorrect installation or removal, or connection to an incorrect power source by the owner. The Company neither assumes, nor authorizes any person or entity to assume for it any obligation or liability associated with its products. Light bulbs and fuses are not covered under this warranty. If you have any questions regarding the warranty or service, please contact us at **customercare@jrhome.com**.

Customer Service :

JR Home Products

Unit 306 - 19100 Airport Way, Pitt Meadows, BC V3Y 0E2

Toll Free : 1-800-561-5550

E-mail : **customercare@jrhome.com**

AVERTISSEMENT

Ce produit a été soigneusement inspecté, testé et emballé afin de minimiser les risques de dommages durant le transport. Si l'une des pièces (à l'exception des verres, des ampoules électriques et des fusibles*) s'avère défectueuse au niveau de sa fabrication ou de ses matériaux dans l'année qui suit la date de l'achat suite à une utilisation normale, la pièce sera réparée ou remplacée. La compagnie est tenue de réparer ou remplacer les pièces défectueuses à sa discrétion, en vertu de la garantie. Tous frais ou dommage résultant de l'installation, du démantèlement ou du transport du produit demeurent la responsabilité du client et n'est pas couvert par cette garantie. Le client assume tout autre risque résultant de l'utilisation correcte ou fautive du produit. La garantie devient nulle si la compagnie détermine que le dommage ou le mauvais fonctionnement est causé par un accident, une modification, une mauvaise utilisation, un abus, une mauvaise installation ou un mauvais démantèlement ou un branchement à une source électrique inadéquate de la part du client. La compagnie n'est pas responsable et n'autorise quiconque, personne ou entité légale, à accepter de responsabilité ou obligation en son nom, en rapport avec ses produits. * Les ampoules électriques et les fusibles ne sont pas couverts par cette garantie. Pour toute question au sujet de la garantie ou du service, contacter le service à la clientèle à : **customercare@jrhome.com**.

Service à la clientèle:

JR Home Products

Unit 306 - 19100 Airport Way, Pitt Meadows BC V3Y 0E2

Numéro sans frais: 1-800-561-5550

Courriel: **customercare@jrhome.com**

You MUST register your product within 30 days of purchase to receive warranty service.

Registration can be completed online at www.jrhome.com or by mailing this form.

Vous DEVEZ enregistrer votre produit dans les 30 jours suivant l'achat pour bénéficier du service de garantie.

L'enregistrement sera complet une fois que vous aurez posté ce formulaire ou que vous serez inscrit en ligne.

Warranty Registration Information Form / Formulaire d'enregistrement de la garantie

Name / Nom : _____

Street / Adresse : _____

City / Ville : _____

Province / Province : _____

Postal Code / Code postal : _____

Daytime Phone # / No téléphone jour : _____

Evening Phone # / No téléphone soir : _____

E-Mail Address / Courriel : _____

Product/Produit : _____

Place of Purchase / Lieu de l'achat : _____

Date of Purchase / Date de l'achat : _____

Model # / No de modèle : _____

Serial # / Numéro de série : _____

You MUST register your product to receive warranty service.

For warranty service, contact J&R Home Products at the address, phone numbers listed below within 30 days of purchase. Be sure to have your sales receipt and original date of purchase. All warranty service will be coordinated by J&R Home Products service center.

Vous DEVEZ enregistrer votre produit pour vous prévaloir de la garantie.

Afin de faire valoir la garantie, communiquez avec J&R Home Products à l'adresse et aux numéros indiqués ci-dessous dans les 30 jours suivant la date d'achat. Ayez en main votre reçu et la date d'achat. Toutes les demandes liées aux garanties seront traitées par le centre de service de J&R Home Products.

