















Assembly Instruction

A		Headboard	1pc
B		Footboard	1pc
C		Side Rail	4pcs
D		Headboard Legs 500 x 80 x 20mm	2pcs
E		Footboard Legs 100 x 32 x 90(H)	2pcs
F		Side Rail Legs No.124 - 180 x 80 x 30mm	2pcs
G		12 pcs slat 997mm	2pcs
H		JCBB M8 x 20	8pcs
I		JCBC M6 x 30	8pcs
J		JCBC M6 x 50	8pcs
K		Allen Key 100mm	1pc
L		Allen Key 70mm	1pc
M		CSK Screw 32mm	24pcs
N		Spring Washers	6pcs
O		Flat Washers	8pcs

Step 1 : Fix the headboard and footboard with legs as shown.

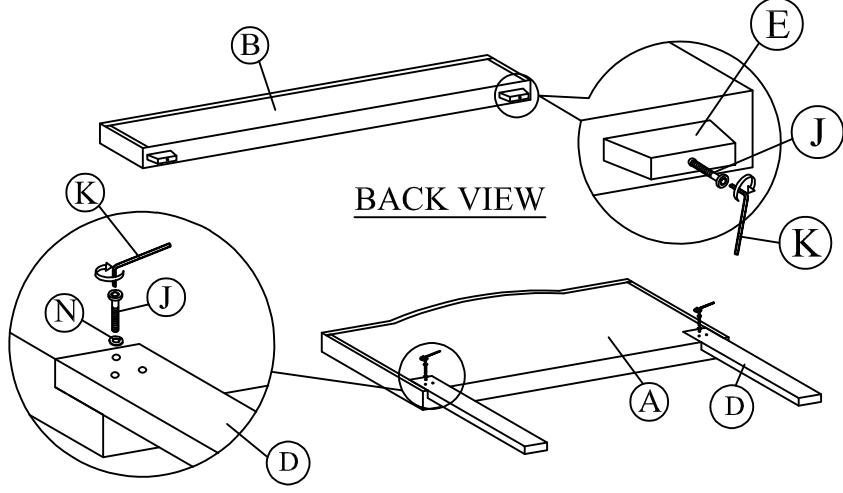

Step 2 : Attach the JCBB Bolt (H) to the headboard and footboard.

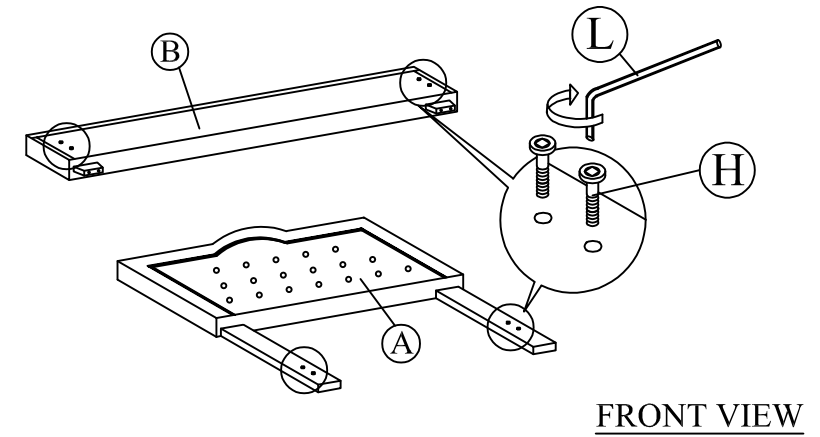

Step 3 : Attach the side rail leg (F) to the side rail (C).

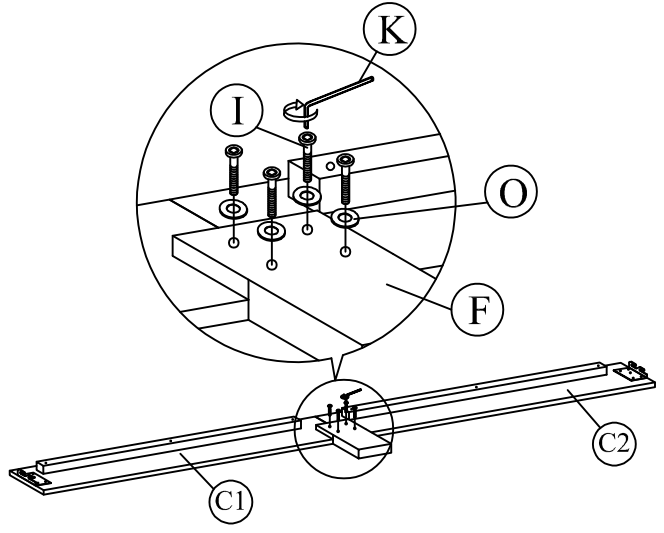



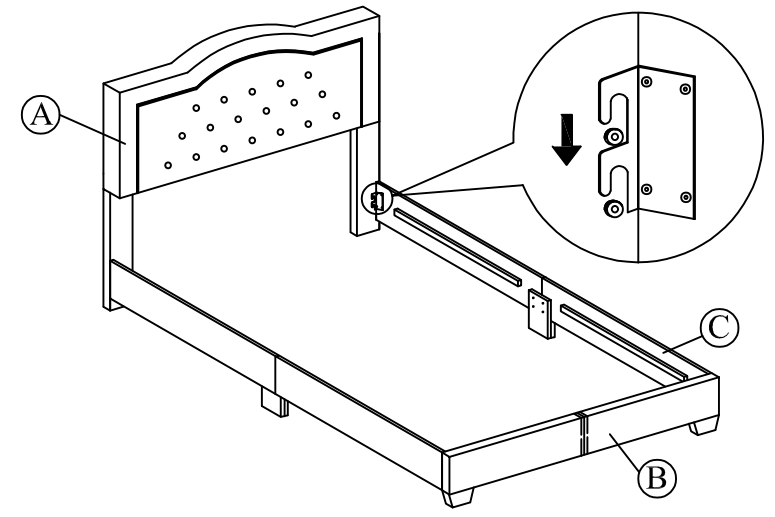

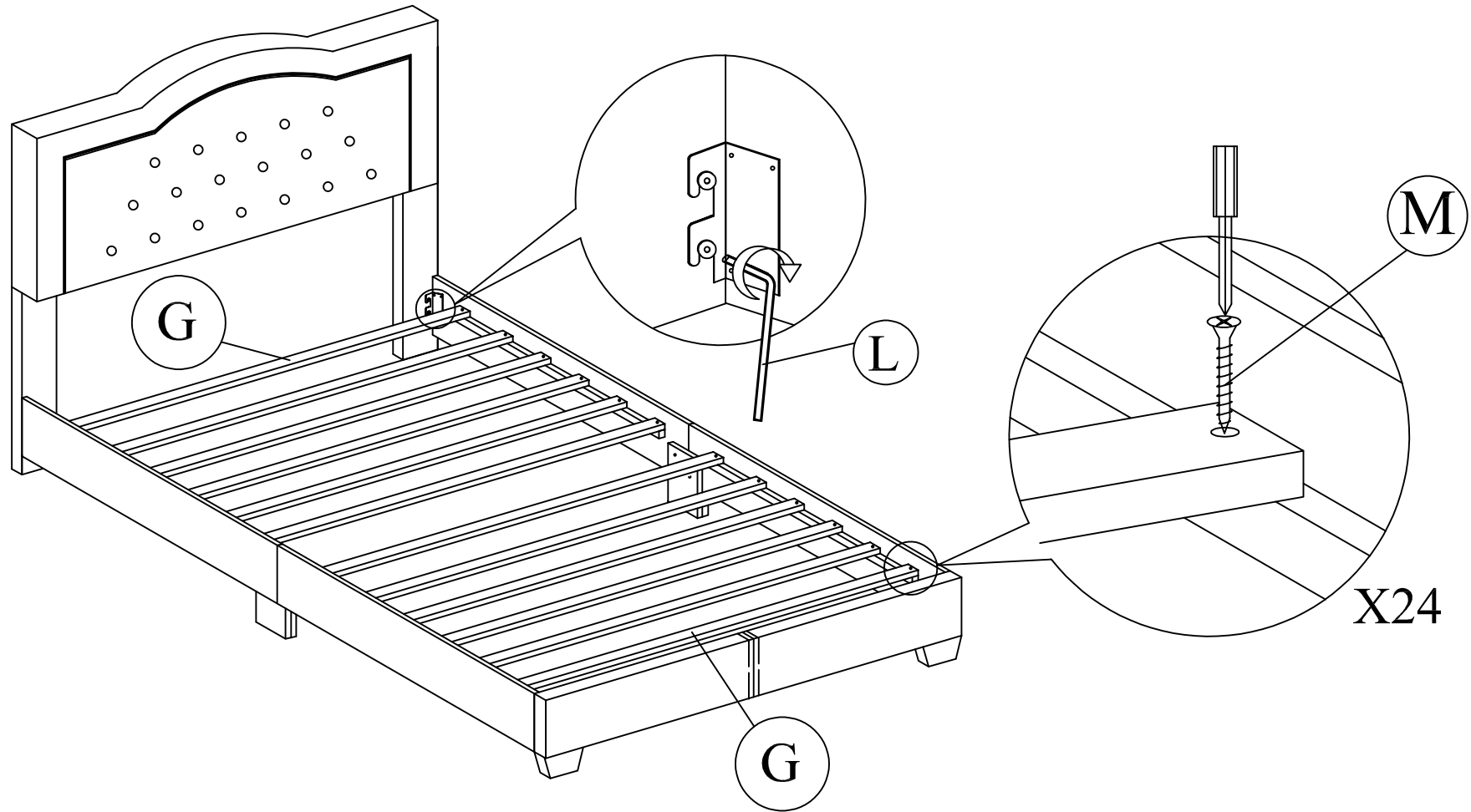

Step 4 : Attach side rail (C) to headboard (A) and footboard (B) by pushing the bracket down to fit it.

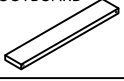
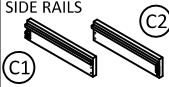

Step 5 : Tighten the 4 Corner with Allen Key (L). Install the bed slats to side rail. Tighten the slats with CSK screw. The distance of the slats should be sufficient to obtain desirable bed stability.

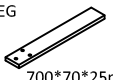

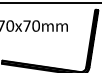
ASSEMBLY INSTRUCTION

NO	ITEM	QTY
A	HEADBOARD 	1 PC
B	FOOTBOARD 	1 PC
C	SIDE RAILS 	4 PCS
D	SLAT  997 mm	2 PCS
E	LEG  700*70*25mm	2 PCS
F	LEG  110x80x35mm	2 PCS
G	SIDE RAIL LEG  20*65*230mm	2 PCS
H	Bolt 1/4" x3-1/2"	2PCS
I	JCBB 1/4" x 1"	8PCS
J	JCBB 1/4" x 2-1/4"	4PCS
K	JCBB 1/4" x 1-1/2"	8PCS
L	M6 FLAT WASHER	22PCS
M	M6 SPRING WASHER	22PCS
N	 1/4"x70x70mm	1PC
O	FLAT HEAD CHIPBOARD SCREW M4 x 25mm 	24PCS
P	WOODEN DOWEL  ø10*35mm	2PCS

Step 1: Fix the headboard with legs as shown.

The height of headboard can be adjusted to accommodate different thickness of mattresses.

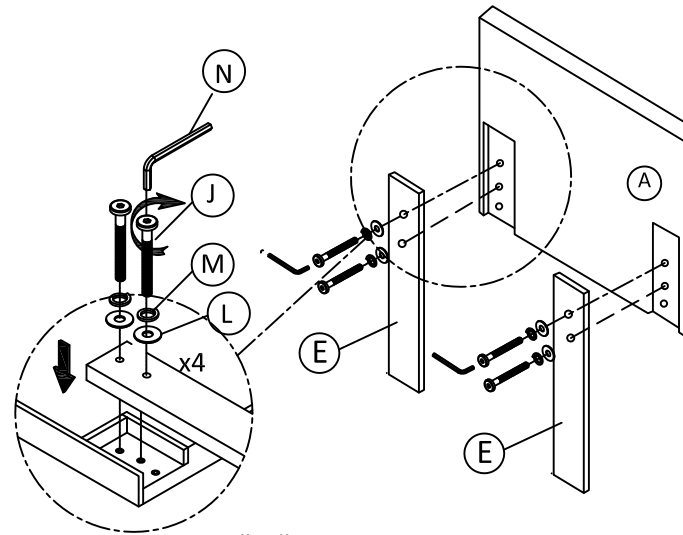
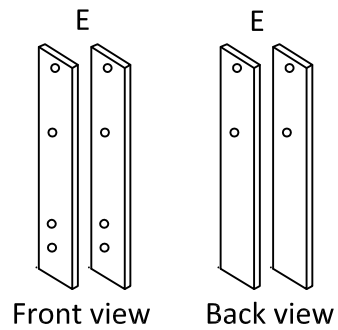

6"-8" Mattress recommended

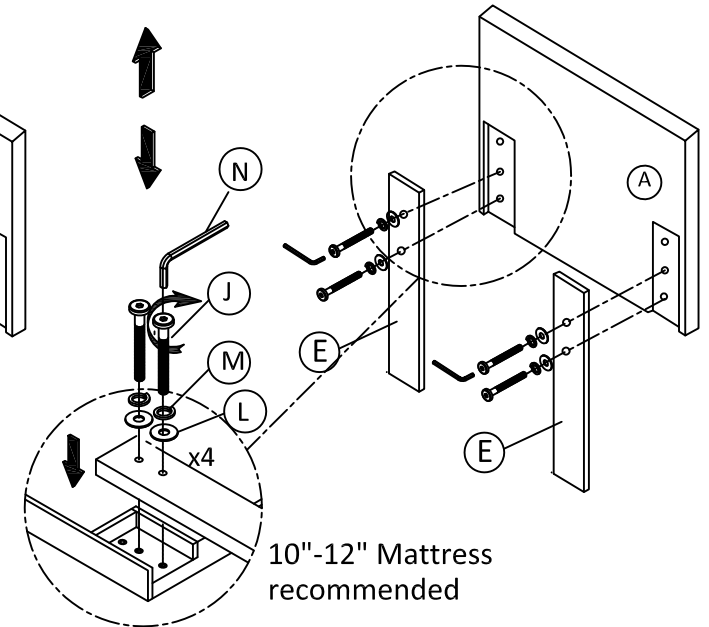

10"-12" Mattress recommended

Step 2: Tighten the Legs (F) to the footboard (B) as shown.

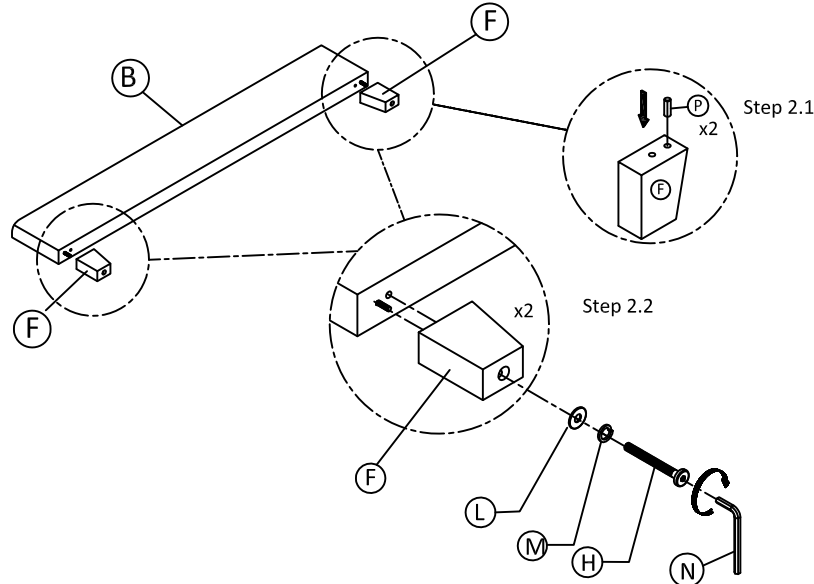

Step 3: Attach the JCBB Bolt(I) to the headboard and footboard.

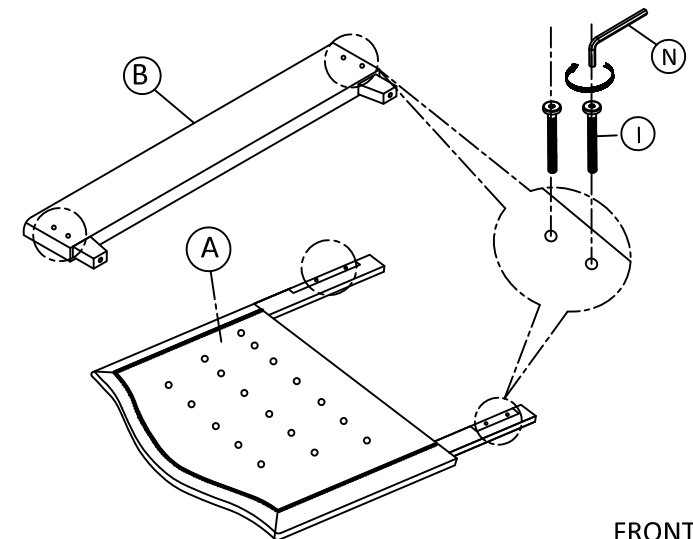

FRONT VIEW

Step 4: Attach the side rail leg (G) to the side rail (C).

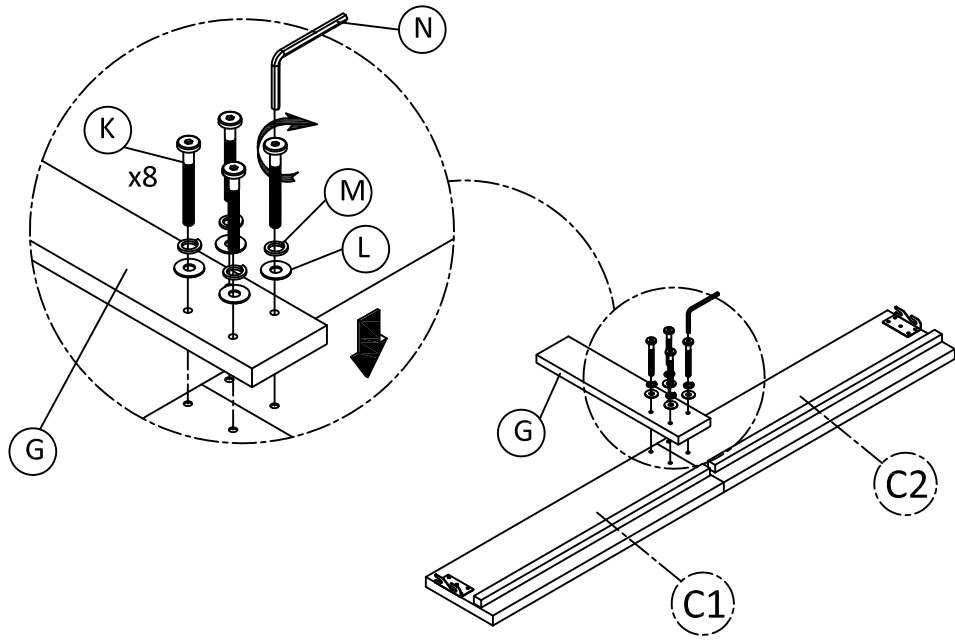

Step 5: Attach side rail (C) to headboard (A) and footboard (B) by pushing the bracket down to fit it.

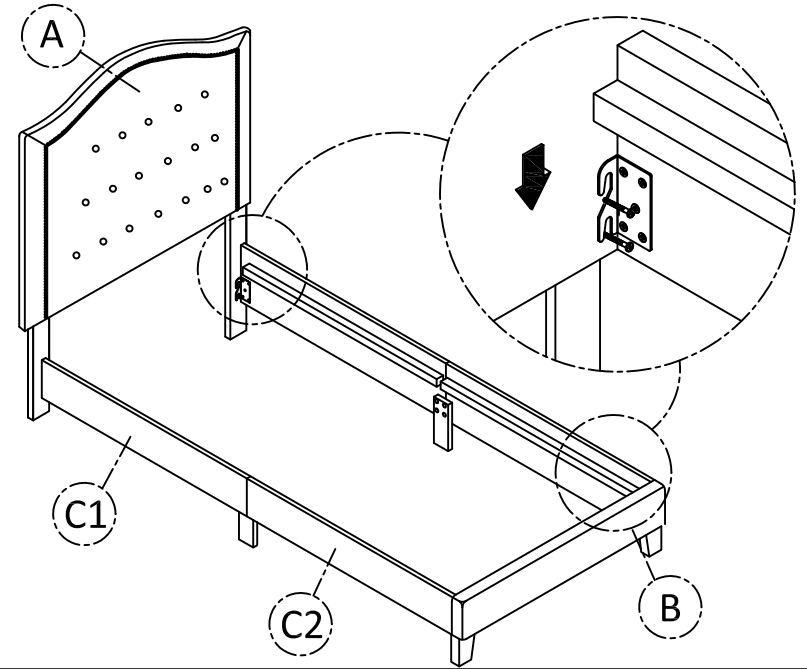

Step 6: Tighten the 4 Corner with Allen (N). Install the bed slats to side rail. Tighten the slats with CSK screw. The distance of the slats should be sufficient to obtain desirable bed stability.

