

OFFICE CHAIR

ASSEMBLY GUIDE

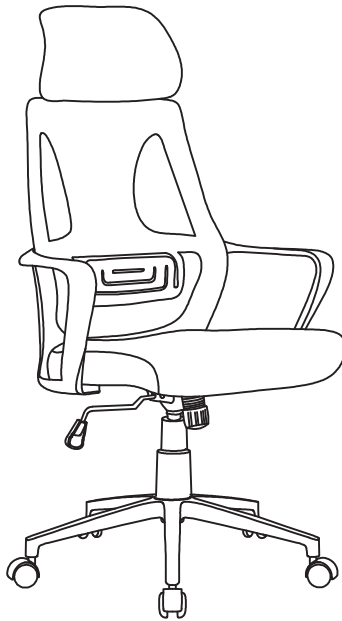

Important - Please read these instructions fully before starting assembly



**SAFETY AND
CARE ADVICE**



NO POWER TOOLS

SAFETY AND CARE ADVICE

- Check you have all the components and tools listed.
- Remove all fittings from the plastic bags and separate them into their groups.
- We do not recommend the use of power drills/drivers for inserting screws, as this could damage the unit. Only use hand screwdrivers and Allen keys.
- Keep children and animals away from the work area, small parts could cause choking if swallowed.
- Make sure you have enough space to lay out the parts before starting.
- Assemble the item as close to its final position (in the same room) as possible.
- Do not overtighten the nuts to avoid causing damage to the threads.
- Only clean using a damp cloth and mild detergent, do not use bleach or abrasive cleaners.
- From time to time check that there are no loose screws on this unit
- This product should not be discarded with household waste. Take to your local authority waste disposal centre

IMPORTANT INFORMATION



15 MINUTE
BUILD











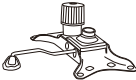





TWO
PERSON



MAXIMUM
CAPACITY 110Kg

PLEASE CHECK CAREFULLY AND MAKE SURE YOU HAVE ALL FITTINGS AND TOOLS LISTED BELOW BEFORE YOU START.

DESCRIPTION	PART NAME	Q'ty(PCS)	DESCRIPTION	PART NAME	Q'ty(PCS)
①		1	⑥		1
②		1	⑦		1
③		1	⑧		1
④		1	⑨		1
⑤		1	⑩		5

A		BOLT M6x20mm	8 PCS
B		BOLT M6x35mm	4 PCS
C		BOLT M6x20mm	2 PCS
D		PLASTIC COVER	1 PCS
E		ALLEN KEY	1 PCS

NOTE: The quantities above are the correct amount to complete the assembly.
In some cases more fittings may be supplied than are required.

STEP 1

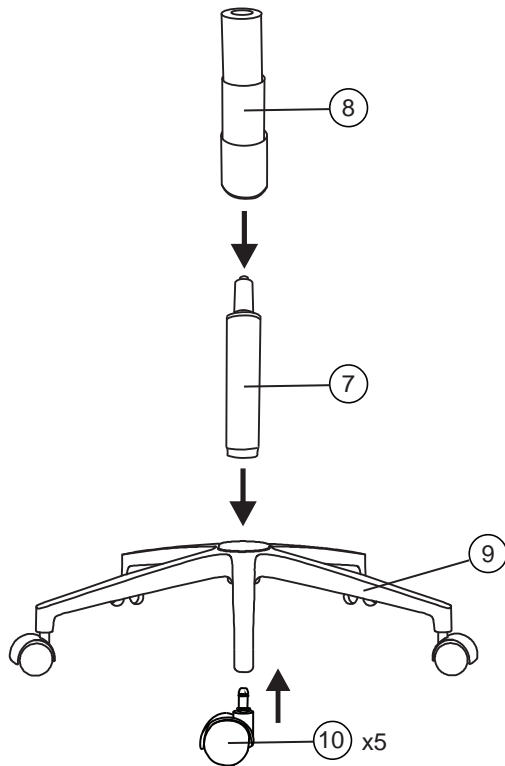

Use a clean, flat, soft surface to avoid any bumps or scratches. Carefully unpack your office chair.
Gently push 1 x castor [10] into each socket of the star base [9]. It should fit snugly without much force.
Insert the gas lift [7] into the center of star base [9] as shown.
Cover the gas lift [7] with telescopic gas lift cover [8] as shown.

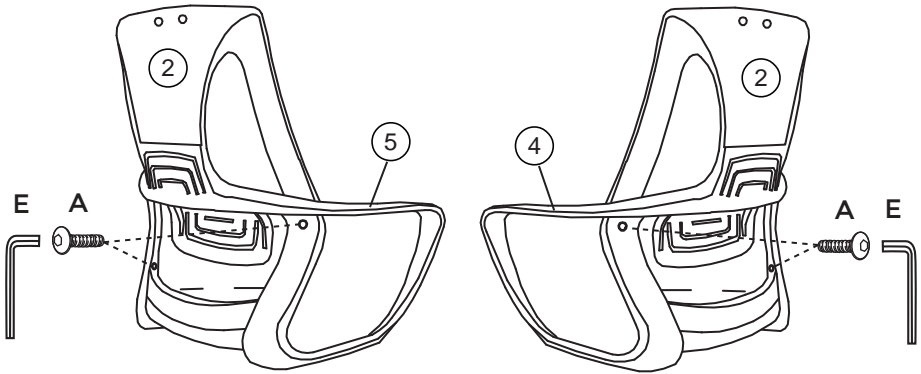

STEP 2

Align left armrest [4] to the pre-drilled holes on backrest [2] as shown. Attach left armrest [4] to backrest [2] with 2 x bolts [A], tighten the bolts using Allen key [E]. Repeat Step 2 with right hand armrest [5].





	
E Allen Key	A M6x20 4 pcs

STEP 3

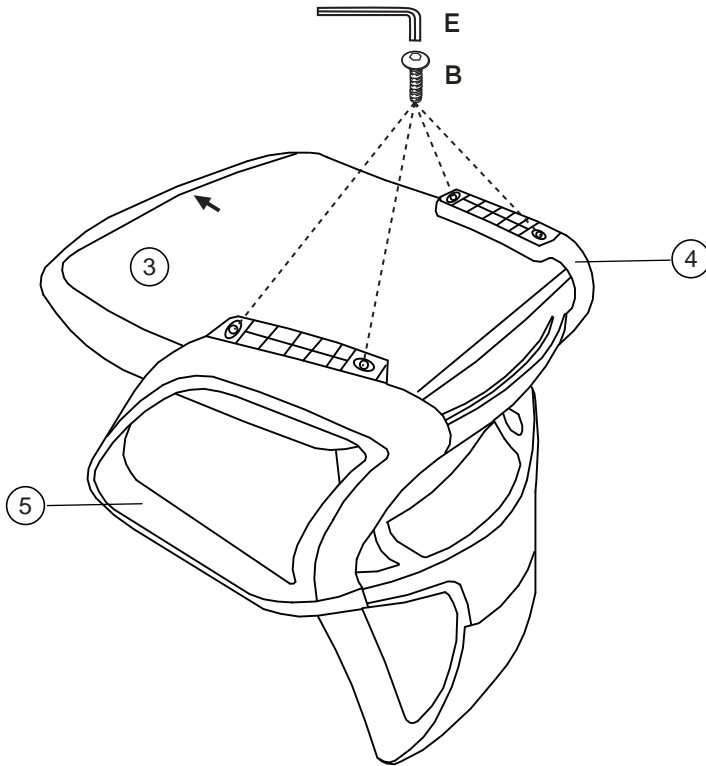
Place seat [3] upside down on a soft surface. Position the back and armrest frame upside down onto seat [3] as shown. Align the back and armrest frame to the pre-drilled holes on seat [3]. Attach with 4 x bolts [B]. Tighten bolts using Allen key [E] as shown.



	
E Allen Key	B M6x35 4 pcs



STEP 4

Align the mechanism [6] onto seat [3], making sure the arrows on both parts are pointing in the same direction.

Attach the mechanism [6] onto seat [3] with 4 x bolts [A].

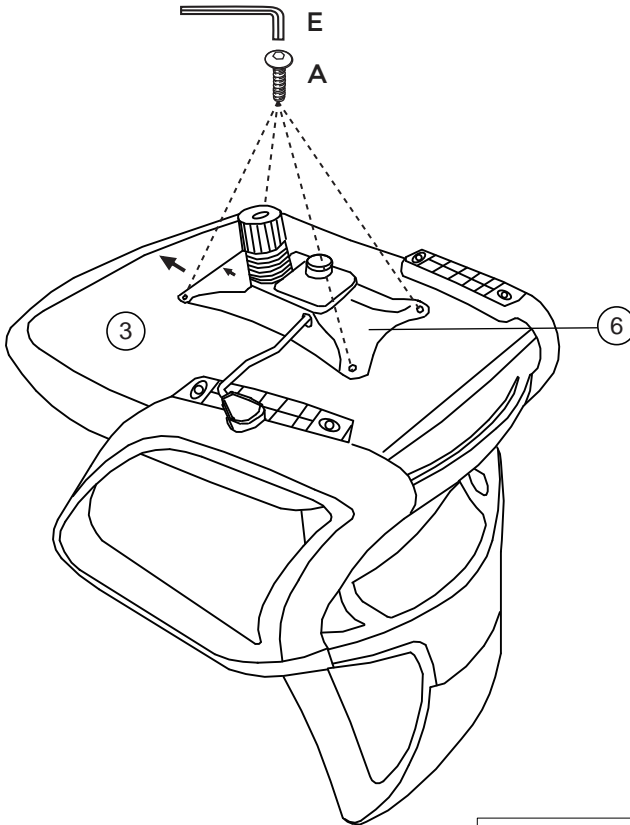
Tighten all bolts using Allen key [E].



	
E Allen Key	A M6x20 4 pcs

STEP 5

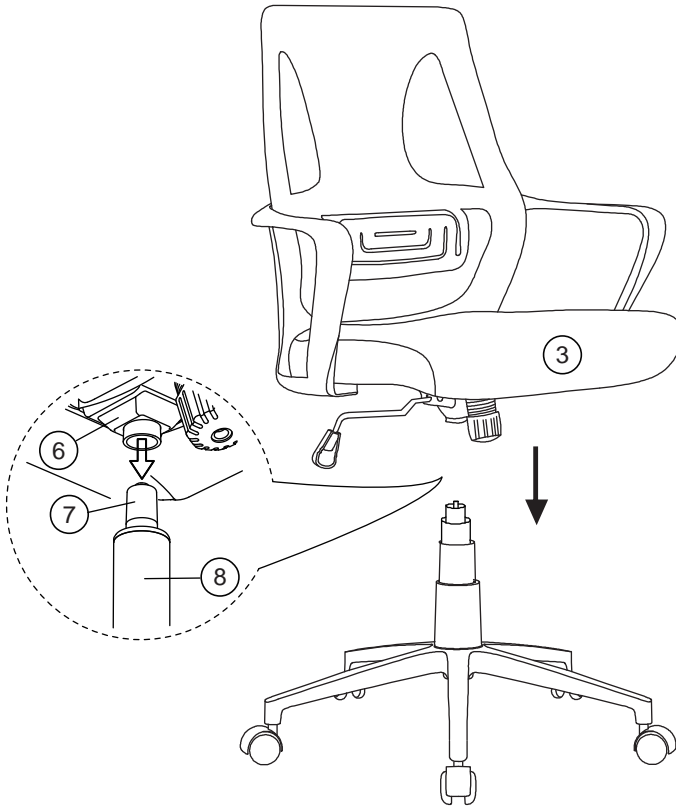

Carefully and with help, place the completed seat onto gas lift [7], making sure the gas lift [7] top is inserted into the hole on mechanism [6] as shown.

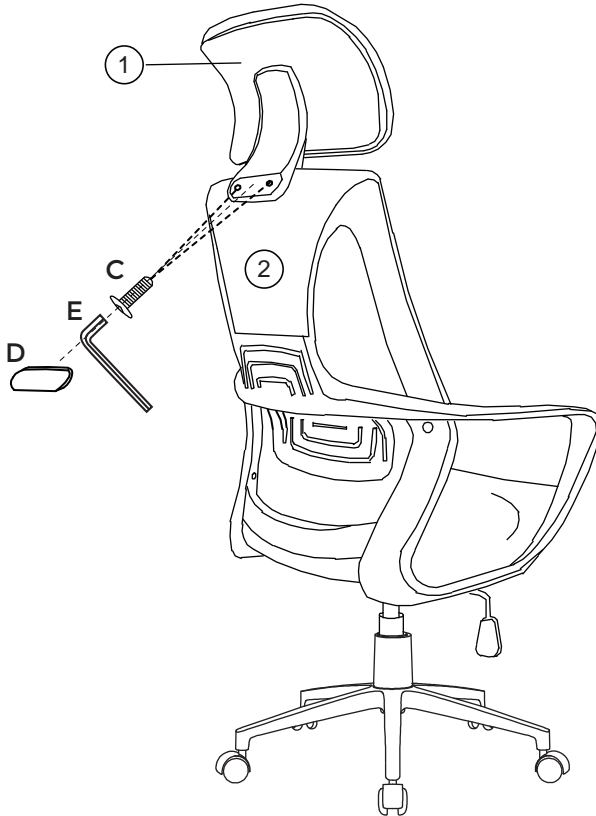

STEP 6

Align the headrest [1] to the pre-drilled holes on backrest [2] and attach with 2 x bolts [C]. Tighten bolts using Allen key [E].
Fit plastic cover [D] onto the headrest [1] as shown.
Your chair is now ready to use!



		
E Allen Key	C M6x20 2 pcs	D Plastic cover



OUR 2 YEAR GUARANTEE

our products come with a 2 year guarantee to give you peace of mind shopping

some garden furniture items have a 1 year guarantee



WHAT THE GUARANTEE COVERS



PRE-INSERTED FIXINGS

e.g. loose metal threads



FAULTY JOINTS

e.g. legs bending



EXTERNAL FIXING FAULTS

e.g. metal discs removing from table top



STRUCTURAL INTEGRITY

e.g. the frame of the product