

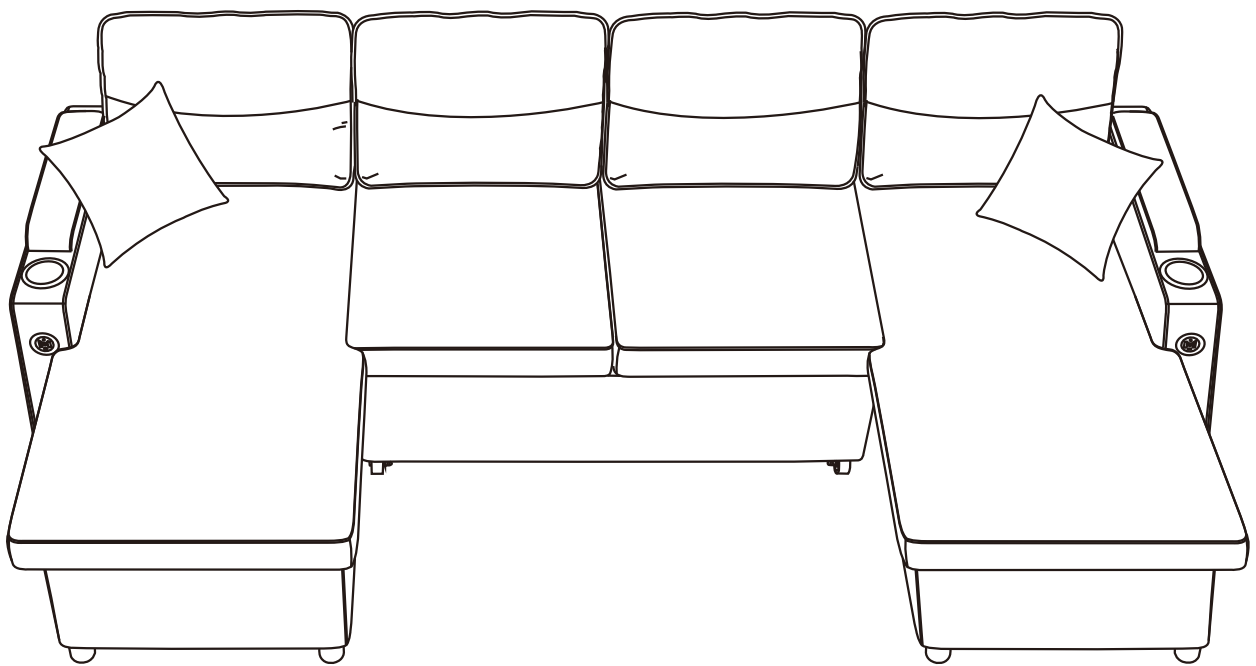







# Convertible Sofa Sleeper

Before the assembly, please open the top lid of armrest and take out all fitting parts in it. Check the parts and quantity with assembly instruction. Any discrepancy, please kindly contact us, thank you!

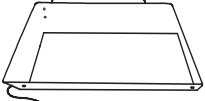
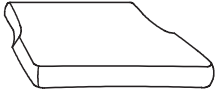





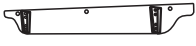



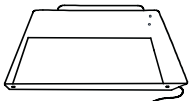





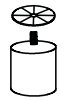



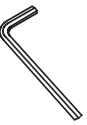

**U shaped sofa**







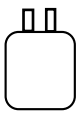



## Box A Parts List

<b>B</b> Chaise  1pc	<b>C</b> Armrest  1pc	<b>F</b> Chaise Cushion  1pc	<b>G</b> Backrest Pillow  2pcs	<b>H</b> Throw Pillow  2pcs	<b>I</b> Iron Frame  1pc
<b>J</b> Iron Frame  1pc	<b>B1</b> Front bezel  1pc	<b>Y</b> Seat frame side panel  2pcs			

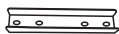







## Box B Parts List

<b>A</b> Sofa Base  1pc	<b>D</b> Armrest  1pc	<b>E</b> Seat Cushion  2pcs	<b>G</b> Backrest Pillow  1pc	<b>K1</b> Backrest Cover  1pc	<b>L</b> Footrest  1pc
<b>N</b> Swyft-loks  6pcs big	<b>O</b> Swyft-loks  2pcs small	<b>P</b> Leg and Plastic Washer  8pcs	<b>S</b> Screw M6*16mm  22pcs M6*16mm	<b>T</b> Screw M6*20mm  4pcs M6*20mm	<b>E1</b> Connecting rods  1pc
<b>U</b> Allen Key  1pc	<b>V</b> Wheel  4pcs	<b>M</b> Swyft-loks  2pcs	<b>A1</b> Pulling bed  1pc	<b>C1</b> Swyft-loks  2pcs big	<b>Q</b> Plastic Square Tube Cap  2pc
<b>F1</b> Angle iron  1pc	<b>G1</b> Angle iron  1pc	<b>Y1</b> Screw M6*30mm  9pcs M6*30mm	<b>C2</b> Swyft-loks  1pcs big	<b>R</b> Screw M6*16mm  20pcs M6*16mm	<b>W</b> Connector  2pcs

## Box C Parts List

<b>B</b> Chaise  1pc	<b>F</b> Chaise Cushion  1pc	<b>G</b> Backrest Pillow  1pc	<b>H1</b> Iron Frame  1pc	<b>K2</b> Backrest Cover  1pc	<b>M</b> Swyft-loks  1pc
<b>N</b> Swyft-loks  2pcs big	<b>O</b> Swyft-loks  2pcs small	<b>P</b> Leg and Plastic Washer  4pcs	<b>S</b> Screw M6*16mm  8pcs M6*16mm	<b>R</b> Screw M6*16mm  4pcs M6*16mm	<b>U</b> Allen Key  1pc

# Step1

B		2
C		1
D		1
P		12
N		4
C1		2
S		12
U		1

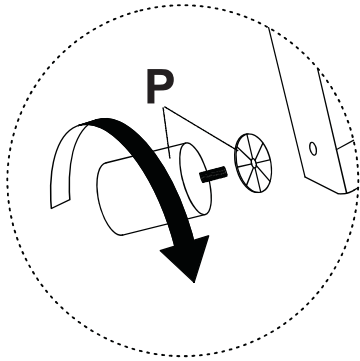

Installaion of sofa legs with plastic washers

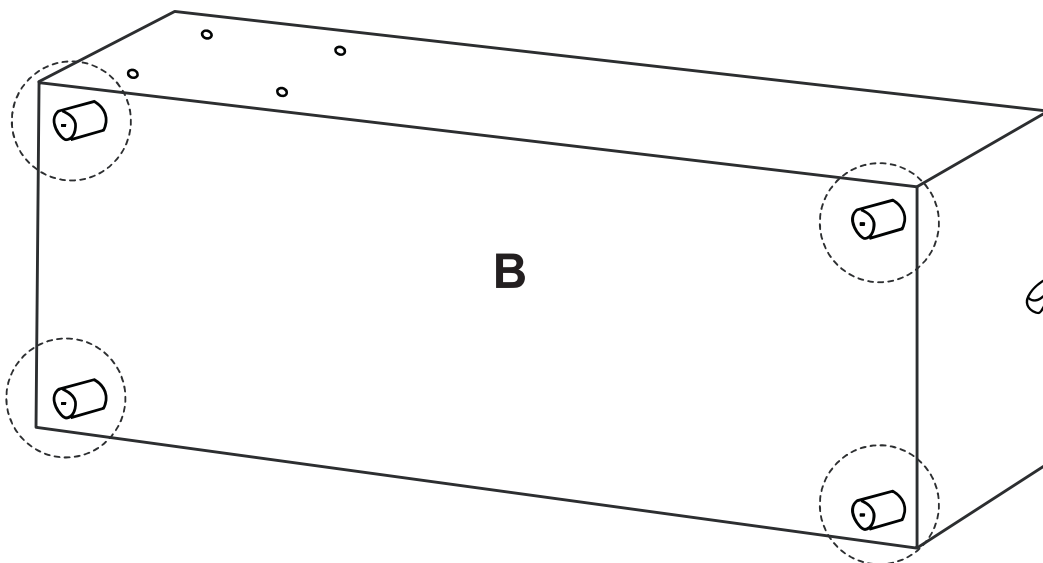
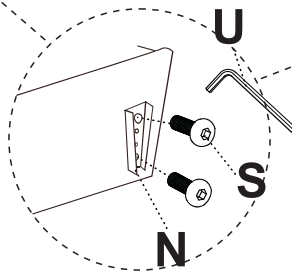
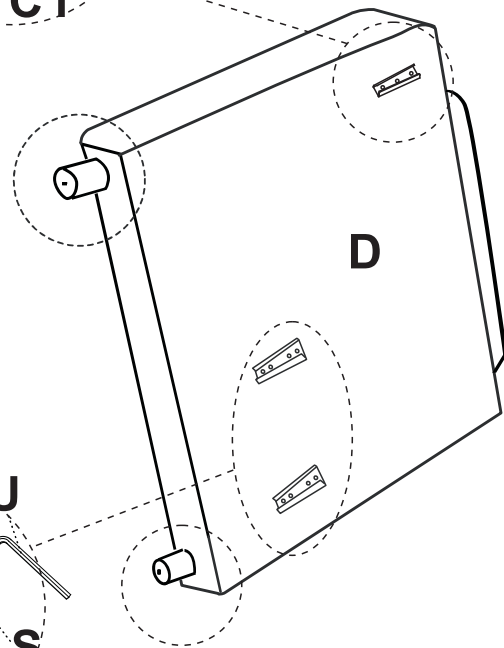
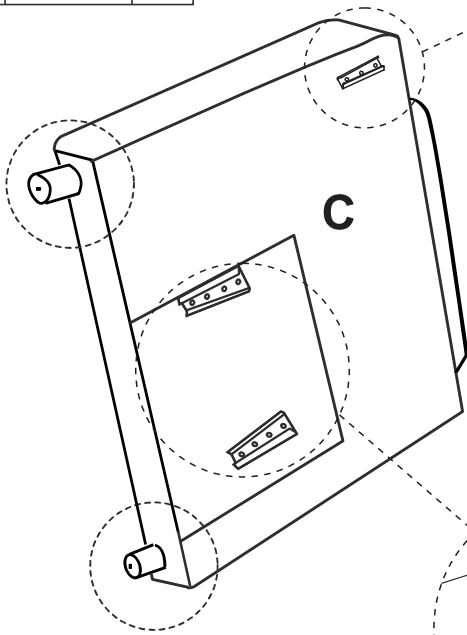
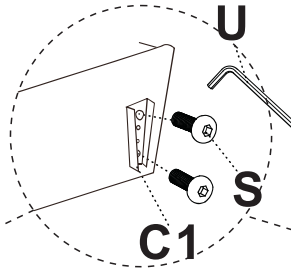







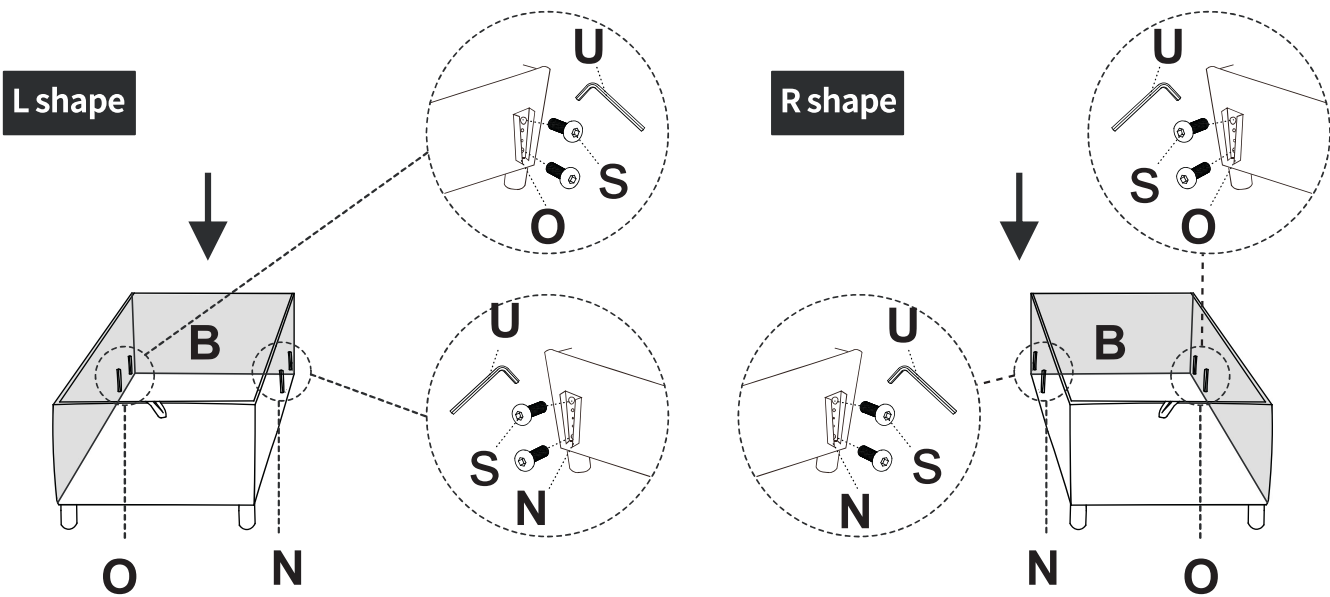
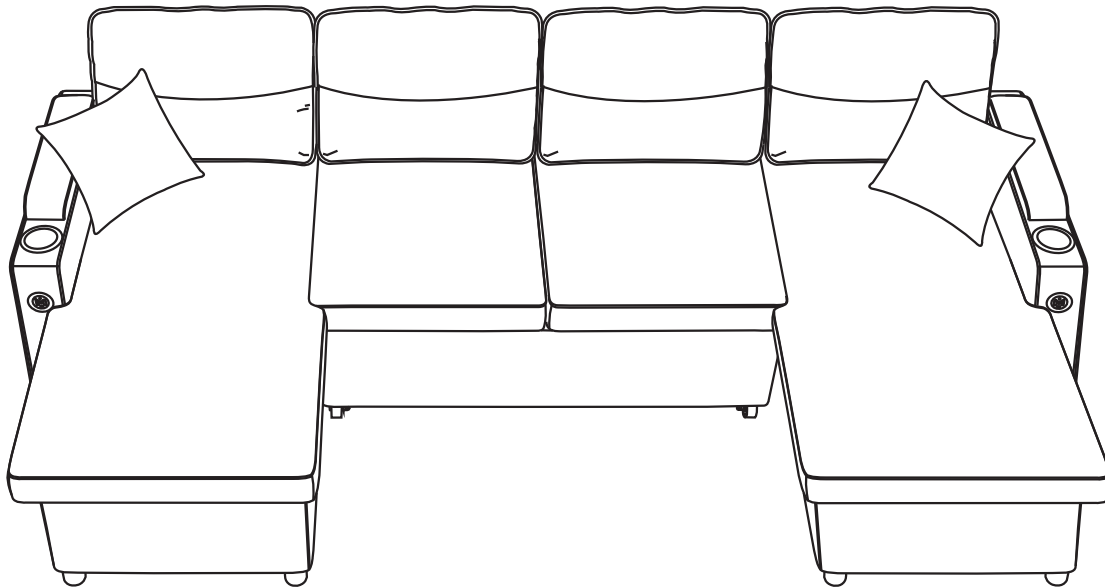

# Please decide the direction of the sofa chaise before your start installation

Check the instructions carefully and install the Swyft-loks in the direction you want the recliner to go, which determines whether the chaise is on the left or the right.

B		2	N		4	O		4	S		16	U		1
---	---	---	---	---	---	---	---	---	---	--	----	---	---	---



Connect Sofa Base& Armrest

Ushape	E1		1	B		2	C		1	D		1
	F1		1	G1		1	R		4	U		1
	T		4									

L shaped sofa(Left Facing)

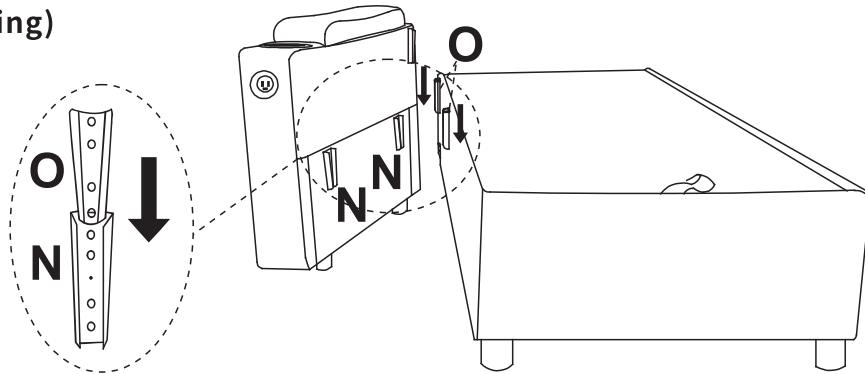

R shaped sofa(Right Facing)

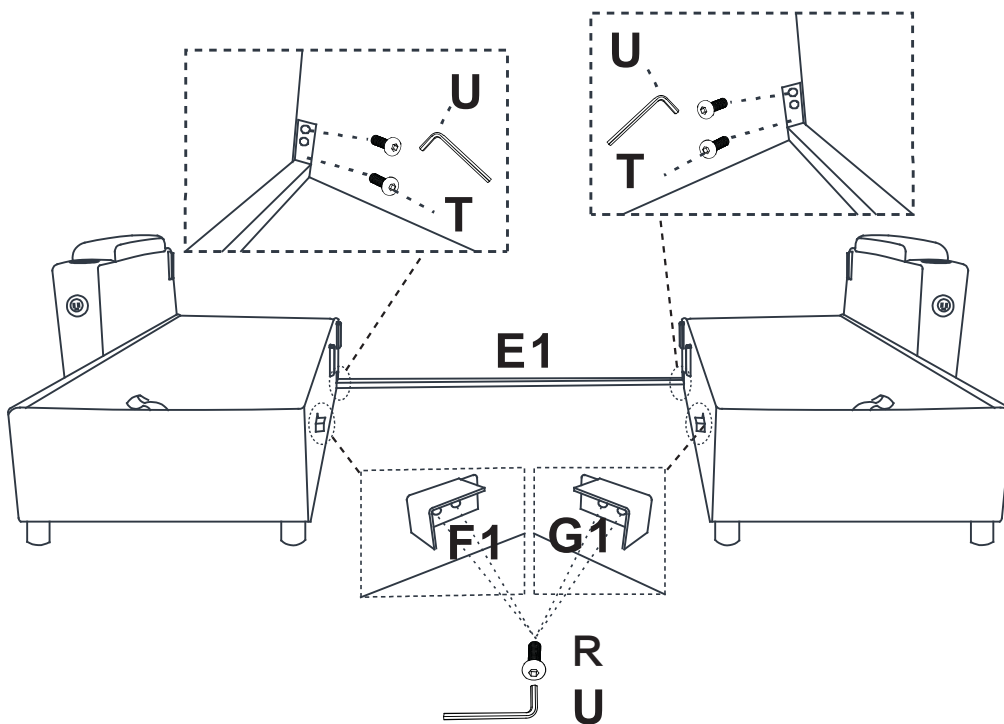
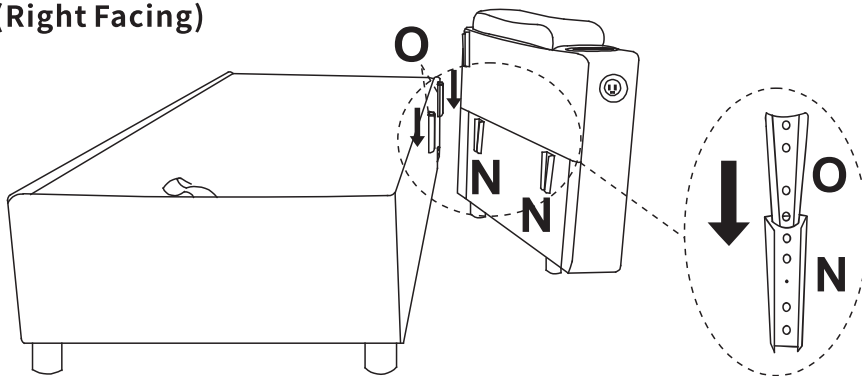

Connect Sofa Base& Armrest

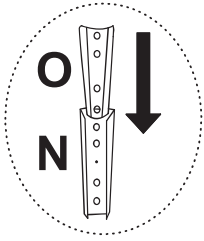

Please kindly note that the small round metal insert part O is inserted into the large square metal insert part N.

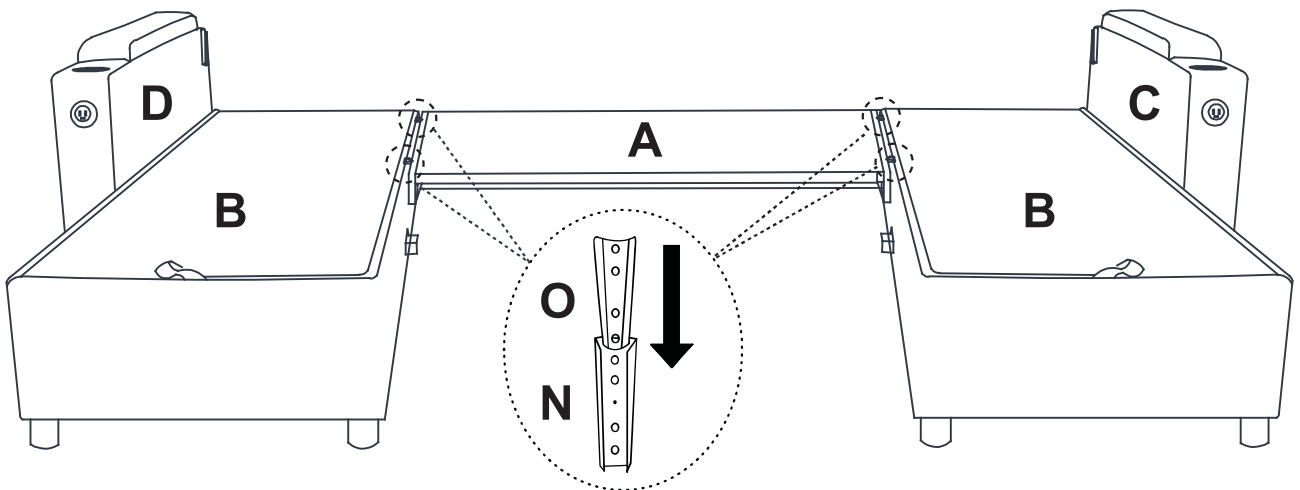
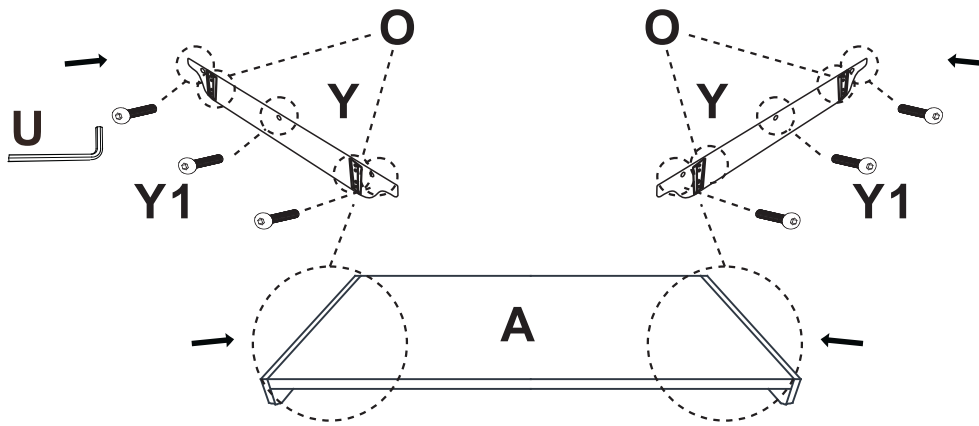

Ushape	A		1	B		2	C		1	D		1
	Y		2	Y1		6	U		1			



# For L Shaped Sofa Only





If the customer purchases a U-sofa, skip this page and discard the metal insert C2, 2 screws S, and 2 plastic covers Q.  
 If the customer purchases an L-shaped sofa instead of a U-shaped sofa.  
 Please add the following 2 steps before starting the production and assembly process.

L shape J  1 Q  2

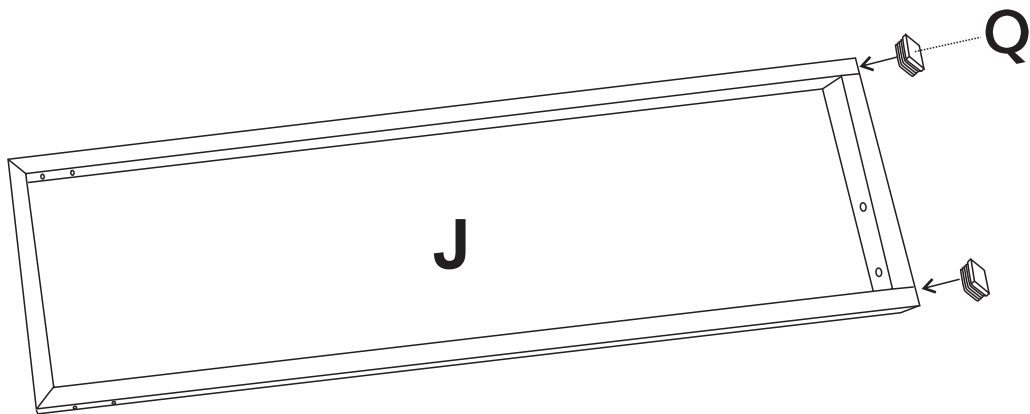
①



Install the two plastic caps Q to the two square tube ports of the rear frame J respectively, be careful not to cut your hands during installation

L shape J  1 C2  1 S  1

②

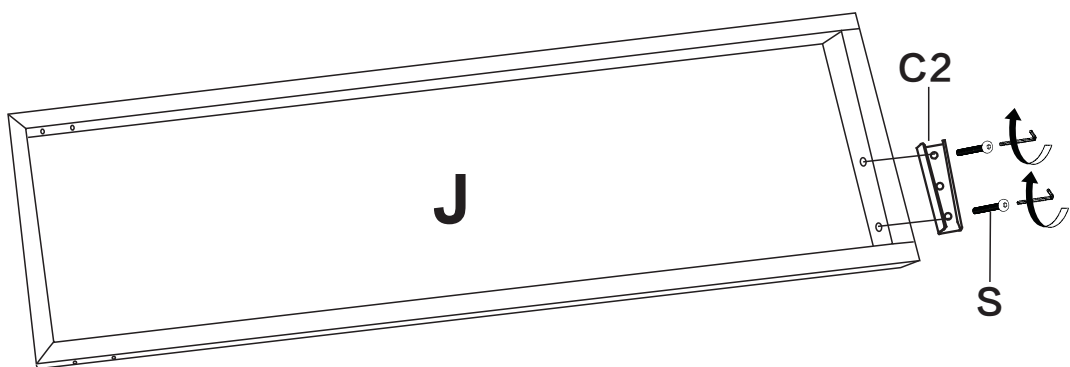

Install metal insert C2 to the rear frame J with screw S

## Appendix

# Step6

Fasten part I & J fittings with the screws R.

Please do NOT tighten any of the 4 screws until they are all aligned.

Then place cover K on frames I and J.

## U Shaped Sofa

I		1	J		1	H1		1	M		3	R		12
U		1	K1		1	K2		1						

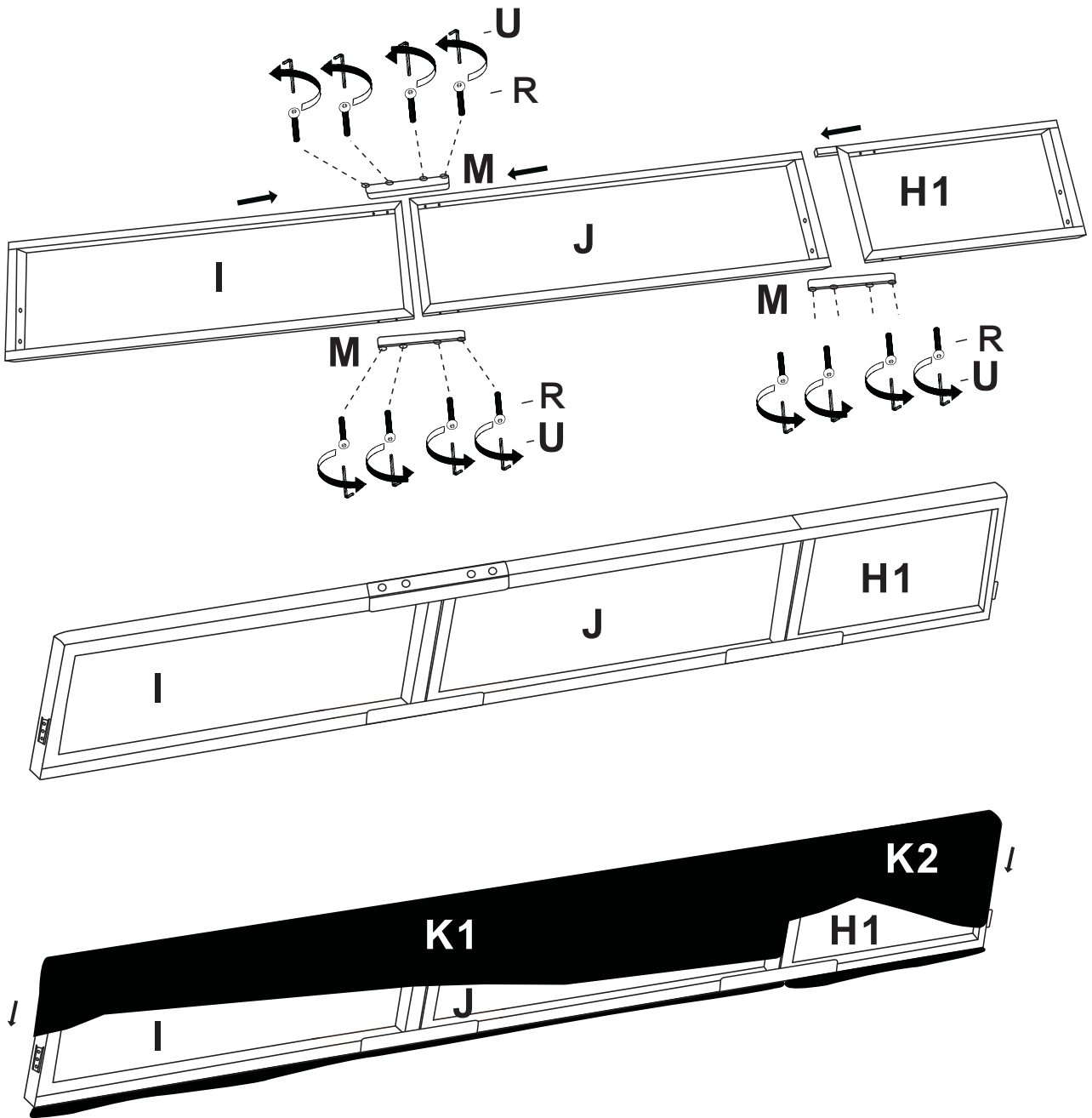

## U Shaped Sofa Insert the backrest into the sofa

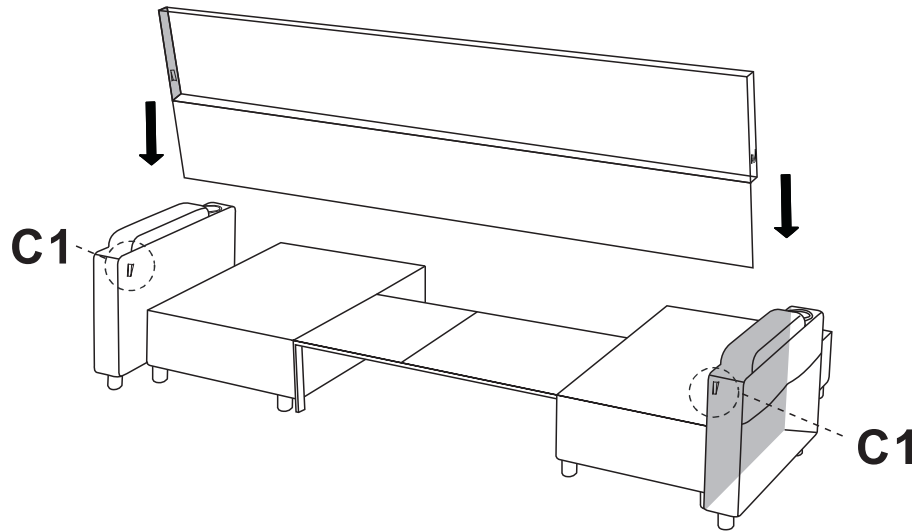



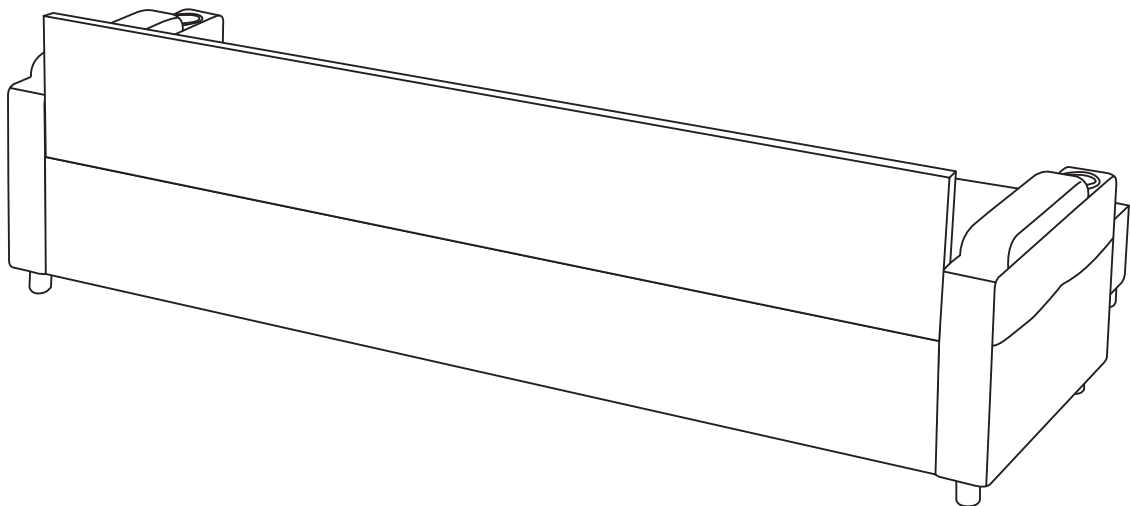

When inserting the iron frame l and j into the sofa, it is oriented so that where the metal clasps are located on both sides, the distance below is shorter than the distance above.





## Step8

Put the screws S into the holes one by one. Please do not lock any one of the 2 screws before they are all aligned. After aligning them all and then tighten them with Allen Key (part U).

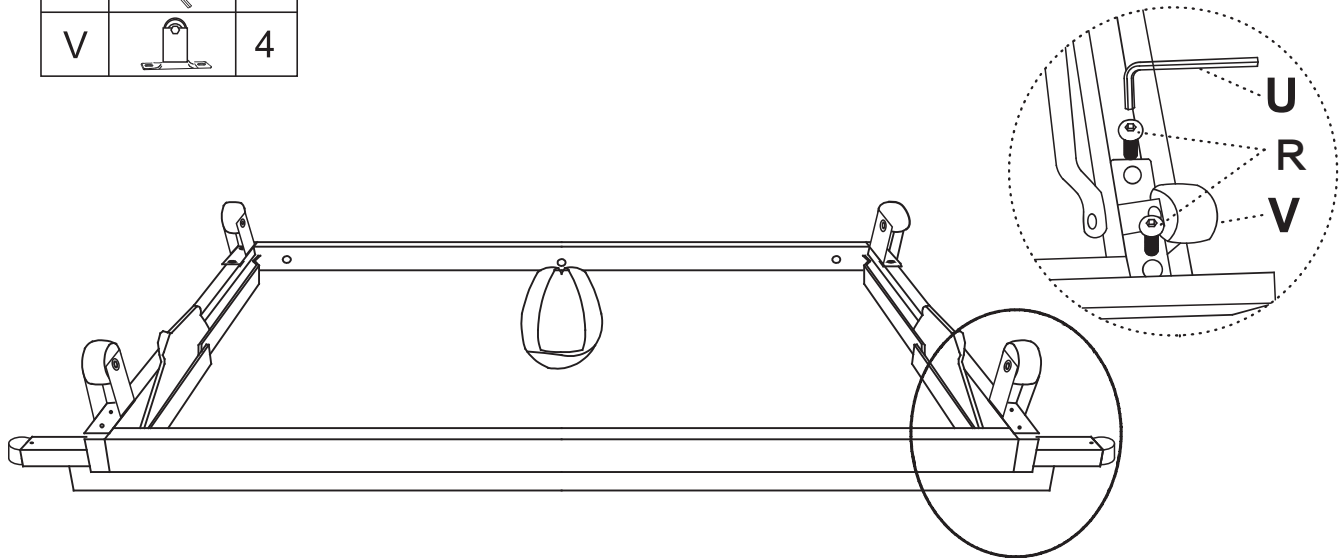
L		1
R		8
U		1
V		4



B1		1
Y1		3
U		1

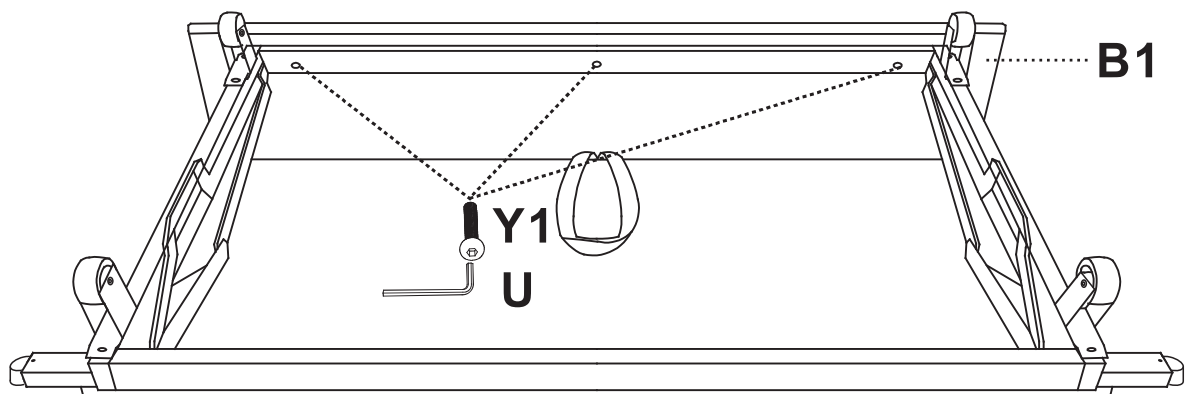

## Step9

Wrapping the Velcro around the iron frame to secure the storage basket. In order to make the installation easier, it is recommended to cover the front and then the back.

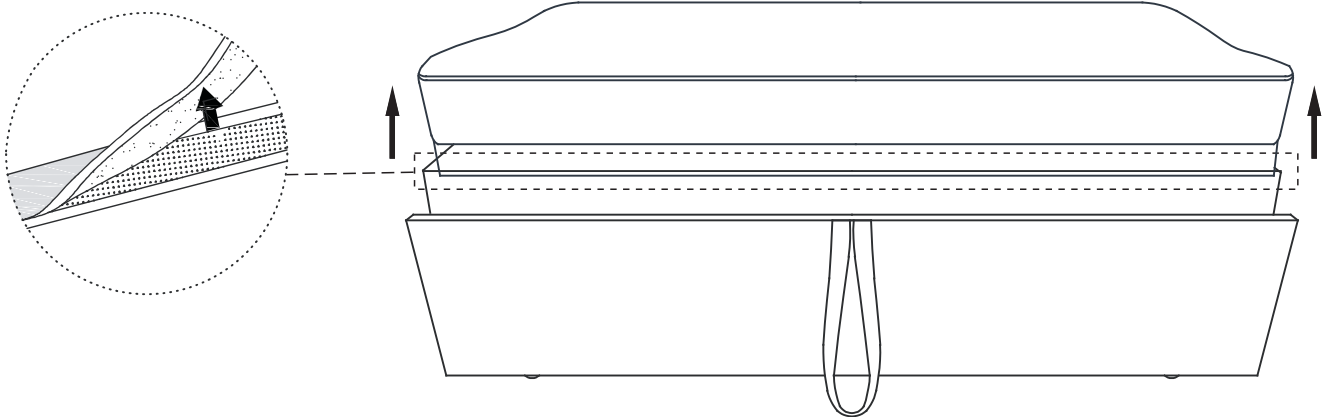
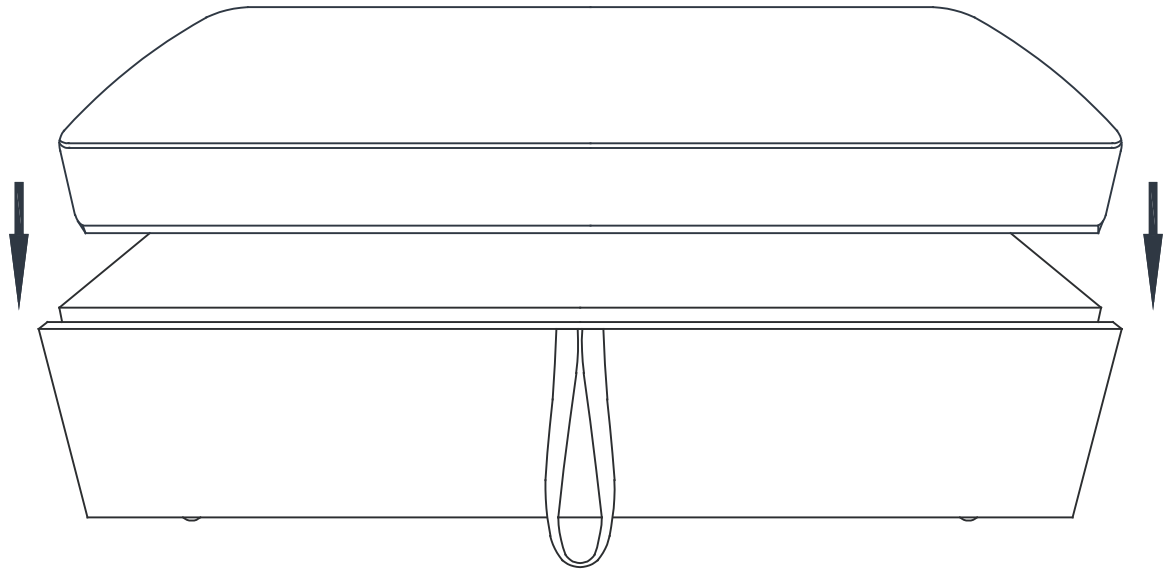
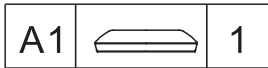

# Step10

Please lift up the footrest L so that the wheels are above the iron frame before sliding into the sofa.

Ushape

L



1

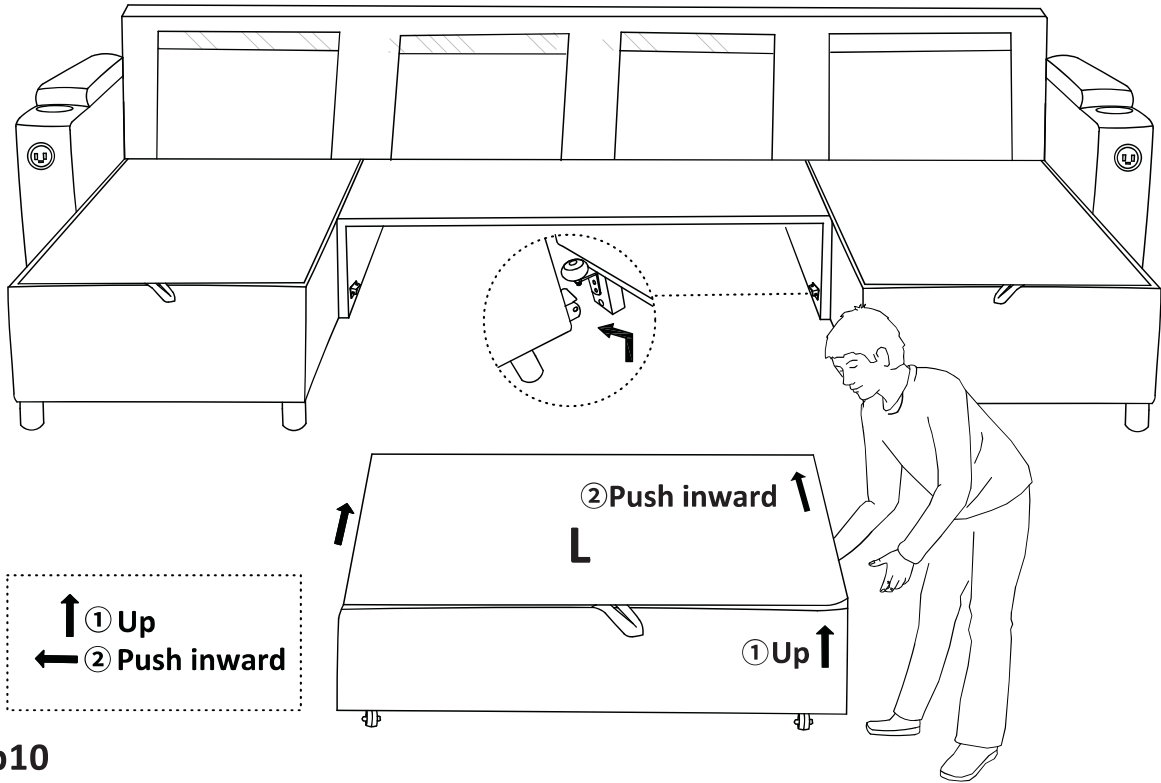

# Step10

Ushape

E



2

F

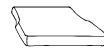

2

G



4

H



2

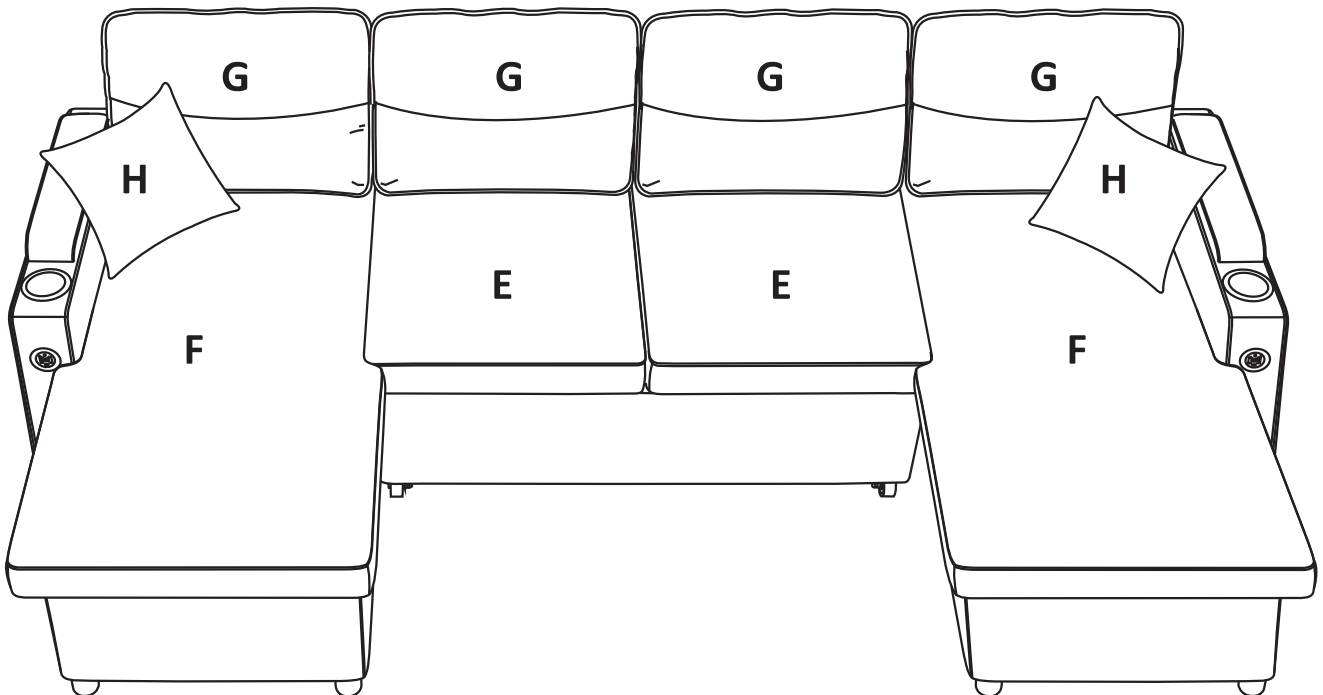

Your cushions come vacuum packed and sealed for shipping. To restore the cushion's original shape, follow the steps below.

After packing up, place them somewhere dry and ventilated. After about 72 hours it can be restored to its best-use condition.

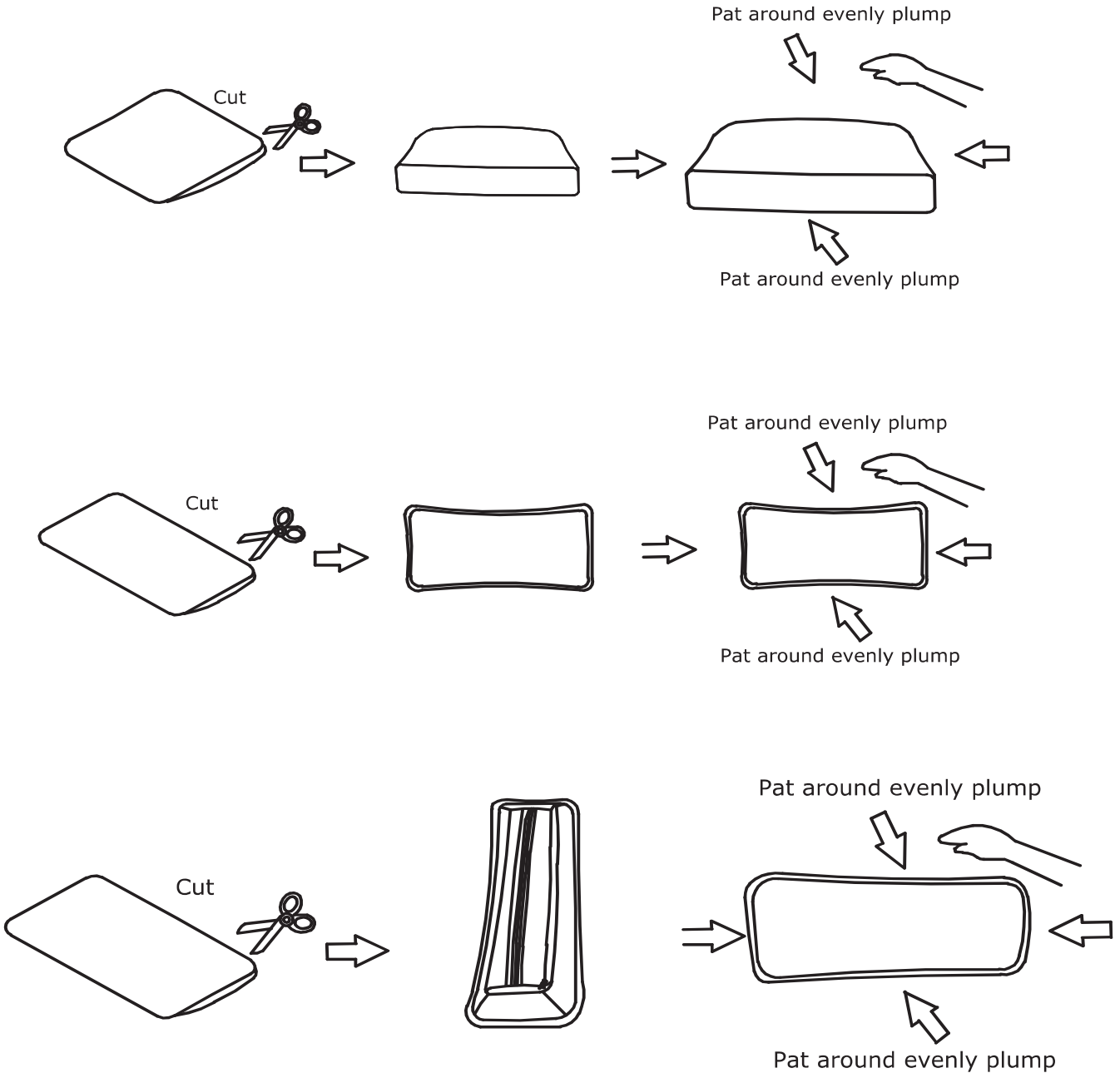

Uneven Fabric is a normal phenomenon that the first time you open it, the fabric is uneven. Because the fabric is easy to crease after long time transport in vacuum compression. You can use an iron to smooth it out, have a try!