

USER MANUAL

LIST

- Page 1. ATTENTION
- Page 2. LIST
- Page 3. A WHOLE UNITE FOUNTAIN.
- Page 4. ONE SET FOUNTAIN WITH TWO PIECES.
- Page 5. TWIST AND LOCK STYLE FOUNTAIN.
- Page 6. FOUNTAIN ATTACHMENT LIGHT
- Page 7. APPENDIX OF LIGHT DIAGRAM 1. & 2.
- Page 8. APPENDIX OF LIGHT DIAGRAM 3. & 4.
- Page 9. APPENDIX OF FOUNTAIN EXTRUSION DIAGRAM

Preparation:

Before beginning assembly, read all warnings and safety precautions!



WARNINGS & CAUTIONS:

Warnings:

To reduce the risk of electric shock, connect pump only to a Ground Fault Circuit Interrupter (GFCI) outlet.

Do not exceed the voltage shown on the pump.

Always disconnect the pump from the power source before performing any maintenance or work on the pump, light(s) or any fountain fittings.

Inspect the power cord for damage before installation and/or maintenance. Replace the entire pump if damage is found.

Clean with damp cloth. DO NOT use any chemicals to clean as they may ruin the finish.

Cautions:

Use a proper power source as indicated on the pump label.

Keep the cord away from high temperatures and/or heat sources.

Do not lift the pump by its power cord.

Keep the fountain out of reach of children.

Do not let the pump run dry. Pump must be completely submerged for proper operation and cooling.

Do not pump heated liquids.

Operate with freshwater only. Avoid heavily chlorinated water and water with high PH levels.

REMARK:

Please be sure that the assembly process is team works. Due to the individual product designing difference, may have a gap with specifications content more or less, we are sorry but we cannot inform besides, understand please.

Diagram of water circulation for a whole unit fountain.

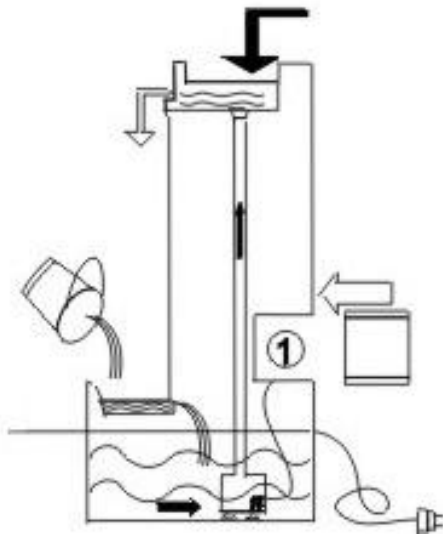

PUMP ASSEMBLY INSTRUCTIONS:

1. Remove the pump from the package and untie the power cord. Adjust the flow rate (if applicable) to the maximum (+) position.
2. Drag out one end PVC tube from the fountain back (as shown in Fig.①.) to connect with the pump. Place the pump in a desired location in the fountain. Close the cover plate (The individual product is not with any cover plate because of structure difference). Always keep the plug out.
3. Add water according to what picture shows. Make sure that water level does not exceed the front and back rock bottom.
4. Connect the power cord from the pump to a properly grounded, grounding type receptacle (GFCI). Processing circuit.

Diagram of water circulation for one set fountain with two pieces, by the perpendicularity links up.

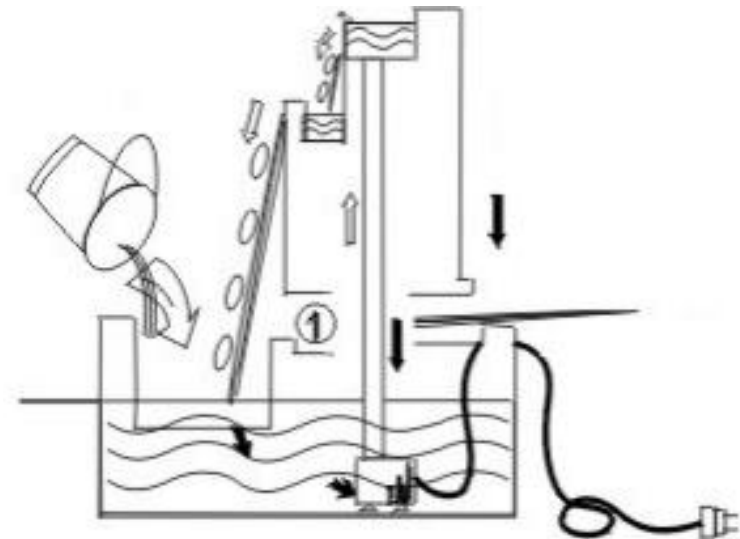

PUMP ASSEMBLY INSTRUCTIONS:

1. Remove the pump from the package and untie the power cord. Adjust the flow rate (if applicable) to the maximum (+) position.
2. Drag out one end PVC tube from the bottom of Fountain Upright (as shown in Fig.①.) to connect with the pump. Place the pump in a suited location in the Fountain Cistern, and assembled the Fountain Upright on the Fountain Cistern at the same time (as what picture shows). Make sure they fitted well.
3. Add water according to what picture shows. Make sure that water level does not exceed the front and back rock bottom.
4. Connect the power cord from the pump to a properly grounded, grounding type receptacle (GFCI). Processing

circuit.

Diagram of water circulation for twist and lock style fountain.

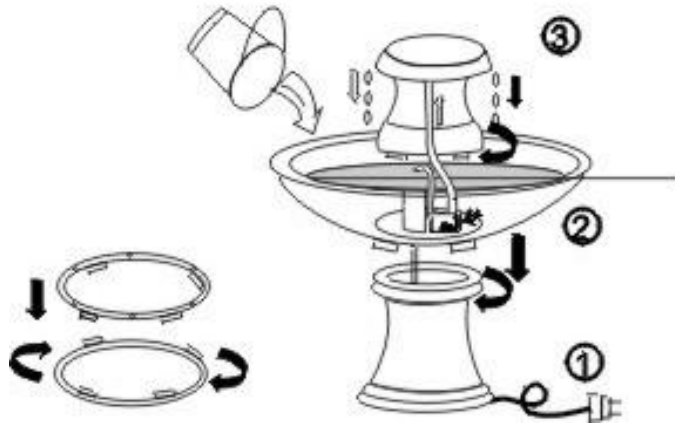

PUMP ASSEMBLY INSTRUCTIONS:

1. Remove the pump from the package and untie the power cord. Adjust the flow rate (if applicable) to the maximum (+) position. Pass the power cord through the middle of the Basin and Pedestal, drag the power cord out from the hole of Pedestal bottom (as what picture shows).
2. Tighten the screws to assemble the Basin and the Pedestal (as shown in Fig.①. & Fig.②.).
3. Drag out one end PVC tube from the bottom of the Fountain Upper-end to connect with the pump. Place the pump in a suited location in the Basin(as shown in Fig.②.).
4. Tighten the screws to assemble the Fountain Upper-end and the Basin (as shown in Fig.②. & Fig.③.).
5. Add water according to what picture shows. Make sure that water level cover the pump fitly just completely.
6. Connect the power cord from the pump to a properly grounded, grounding type receptacle (GFCI). Processing circuit.

Diagram of fountain light(s)

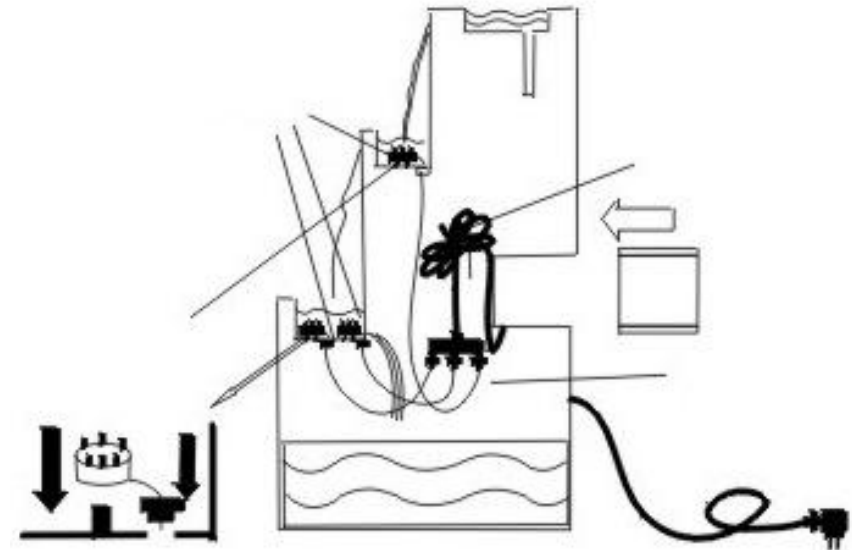

LIGHT ASSEMBLY INSTRUCTIONS:

1. If product design does not contain light, ignore this chapter please
2. Please check accessories light(s) and wiring strategy if the product should attach any light.
3. Remove the transformer from the package.
4. Drag the light(s) cord attachment plug out the fountain, connect it to the transformer.
5. Connect the transformer to a properly grounded, grounding type receptacle (GFCI). Processing circuit.

REMARK:

6. Specifically for the fountain like Page 4., part of light sometimes attached to the Fountain Upright. First of all, please drag the light cord attachment plug out the Fountain Upright, connect it to the light attachment Fountain Infrastructure with a black PVC connector. The other step please invites reference points 2,3,4,5.

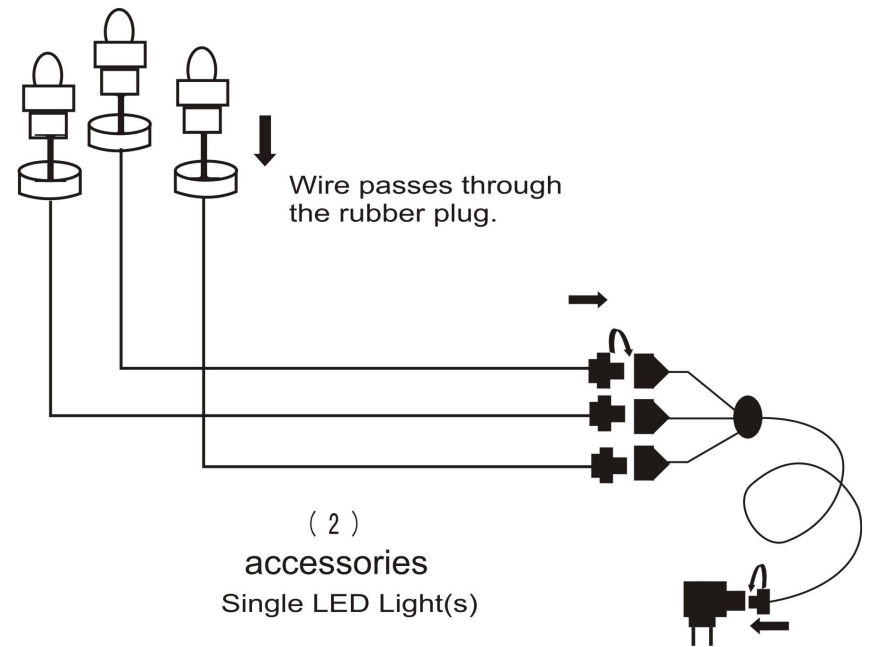
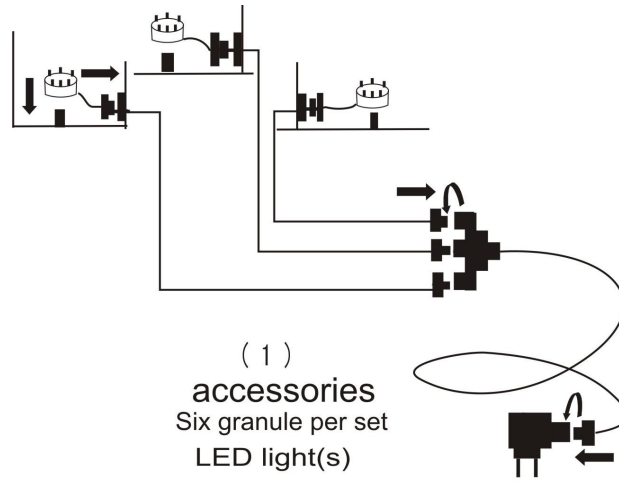

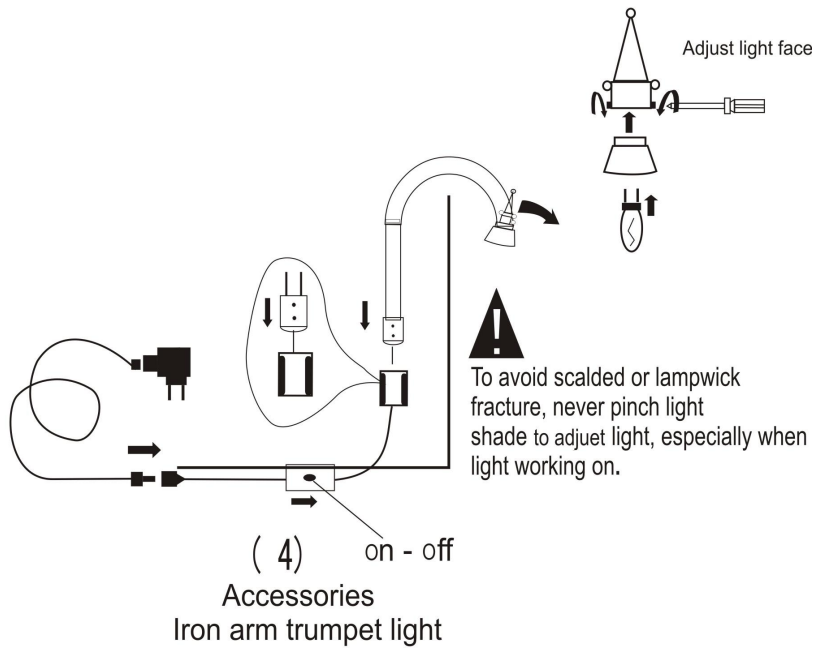
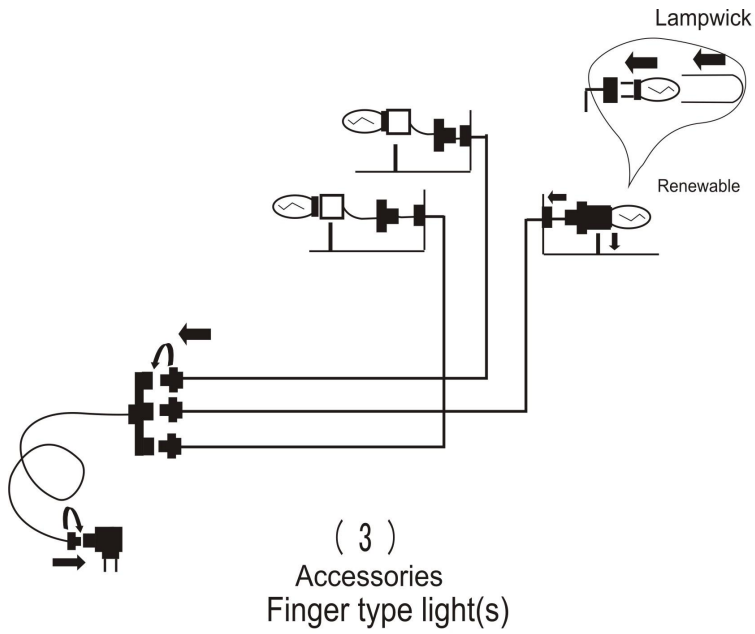

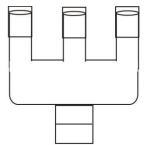
(1)  **Fork - unions adapter**
For great flux, three face outwater.

(2)  **Y - unions adapter**
For great flux, two face outwater.

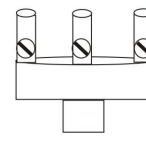
(3)  **Adjustable fork - unions adapter**
To counterpoise water flux.

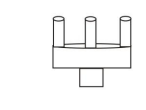
(4)  **Water disperse connection**
To share the running water.

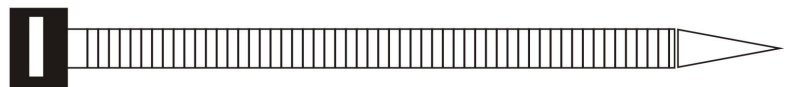
(5)  **Colligation**
To bind the PVC tube with the pump.
Ensure that link up tight.

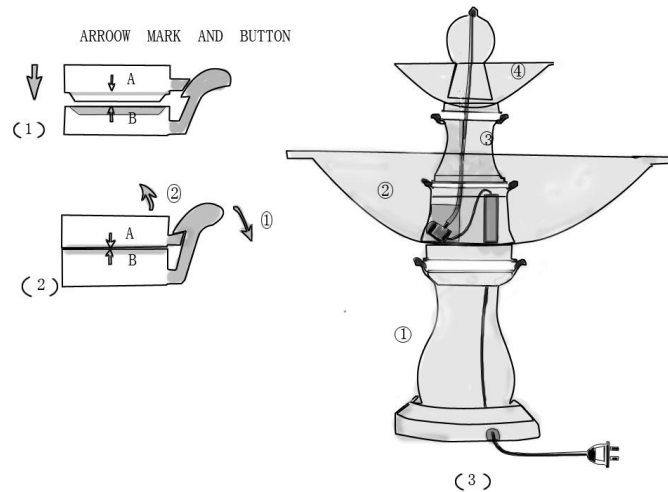

ASSEMBLY INSTRUCTIONS:

1. Place the Pedestal ① on the ground, lift the Basin ② up and find Arrow Mark and Button as picture (1), then set the Basin ② on the Pedestal ① and make sure the button is closed tightly.
2. Remove the pump from the package and untie the power cord. Adjust the flow rate (if applicable) to the maximum (+) position. Pass the power cord through the middle of the Basin and Pedestal, then take the plug out as shown in picture (3).
3. Lift the Fountain Top ④ up, through the water pipe from Middle Pedestal ③, find Arrow Mark and Button then connect them together, make sure the button is closed tightly.
4. Pick up the end of water pipe, connect it with the pump, and put the pump in the suitable location, then close the cover.
5. Fill water into Basin, make sure that water level cover the pump fully just completely.
6. Connect the pump plug to a properly grounded grounding type receptacle (GFCI). Processing circuit.