

This article contains biocidal products to give protection against wood destroying insects & wood rotting fungi. Contents may vary. May contain : Basic copper carbonate (Copper (II) carbonate – Copper (II) hydroxide (1:1), Cupric oxide, Copper hydroxide carbonate, oxyethyl, ammoniumpropionate, Copper HDO, Propiconazole, Tebuconazole, Boric acid, Benzalkonium chloride. Wear gloves when handling freshly treated wood. Avoid breathing dust when cutting treated or untreated wood. Dispose of off-cuts responsibly – do not burn.

Pre-drill
for each screw
used.



Large Pent Tall Garden Store

This fixing pack covers multiple products. Please make sure you quote from the relevant parts list in the event you need to order missing or damaged parts.

Tools Required

Not Supplied

Drill/Pozi Drive
Screwdriver



Hammer



Sharp Knife



Tape Measure



Spirit Level

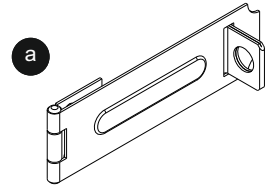

Hasp And Staple Qty 1



25mm Screw Qty 35

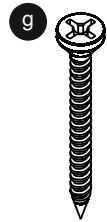

30mm Screw Qty 8

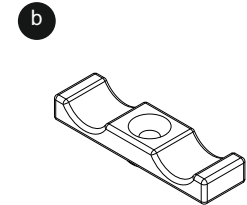

Turn Button Qty 2

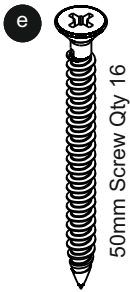

50mm Screw Qty 16



60mm Screw Qty 3

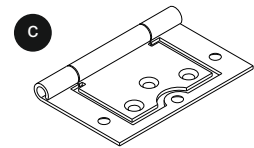

Flush Hinge Qty 4

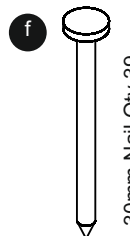

30mm Nail Qty 39

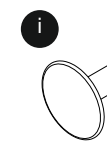

Felt Tacks Qty 30

OPPTGS (Pressure Treated Overlap) PARTS LIST

Item	Part Code	Part Description	Quantity
1	OPTSBP	OLAP PTR TALL STORE BACK PANEL	1
2	OPTSSP	OLAP PTR TALL STORE SIDE PANEL	2
3	SSBLID	SMALL STORAGE BOX LID	1
4	TSFRP	TALL STORE FRONT PANEL	1
5	PTSDR	PTR TALL STORE DOOR	2
6	9534478	OSB 953x447x8mm	1
7	28280953PT	BATTEN 28x28x953mm PTREAT	2
8	38121079PPT	STRIP 38x12x1079mm PAR PTREAT	1
9	45280953PT	BATTEN 45x28x953mm PTREAT	1
10	37281529PT	BATTEN 37x28x1529mm PTREAT	1
11	44121710PPT	STRIP 44x12x1710mm PTREAT	2
12	56120391PAI4PT	BOARD 56x12x391mm PAR ANGLED PTREAT	2
13	38120550PPT	STRIP 38x12x550mm PAR PTREAT	2
14	44161710PT	STRIP 44x16x1710mm PTREAT	2
15	85069	BLACK FELT 1.3 x 1 METRE	1

SPPTGS (Shiplap) PARTS LIST

Item	Part Code	Part Description	Quantity
1	SPTSBP	SLAP PTR TALL STORE BACK PANEL	1
2	SPTSSP	SLAP PTR TALL STORE SIDE PANEL	2
3	SSBLID	SMALL STORAGE BOX LID	1
4	TSFRP	TALL STORE FRONT PANEL	1
5	PTSDR	PTR TALL STORE DOOR	2
6	9534478	OSB 953x447x8mm	1
7	45280953PT	BATTEN 45x28x953mm PTREAT	1
8	38121079PPT	STRIP 38x12x1079mm PAR PTREAT	1
9	28280953PT	BATTEN 28x28x953mm PTREAT	2
10	37281529PT	BATTEN 37x28x1529mm PTREAT	1
11	44121710PPT	STRIP 44x12x1710mm PTREAT	4
12	56120391PAI4PT	BOARD 56x12x391mm PAR ANGLED PTREAT	2
13	38120550PPT	STRIP 38x12x550mm PAR PTREAT	2
15	85068	GREEN FELT 1.3 x 1 METRE	1

Attention:

- For Domestic Use Only.
- Must be built on a **solid and level** base.
- Regularly check that all fixing are tight and secure.
- Regularly check the felt for damage.

Important:

Assembly of this product requires a minimum of two adults.

Please check all parts prior to assembly.

This product is pressure treated to ensure longevity of all timber components and to protect against rot. This may leave a colour difference on some parts that will even out as the moisture content stabilises. This will not need additional treatment.

- Please keep all plastic bags and small parts away from children.
- The roof of this product is not a load bearing structure.
- Timber is a natural material and will shrink and swell as a result of varying moisture content.

Assembly of damaged parts may be deemed to be acceptance and this may affect the remedies you are entitled to.

If the product is not constructed in accordance with the instructions, or is altered in anyway (e.g. painted), the manufacturer cannot be held liable for any resulting damage.

A

Floor Assembly

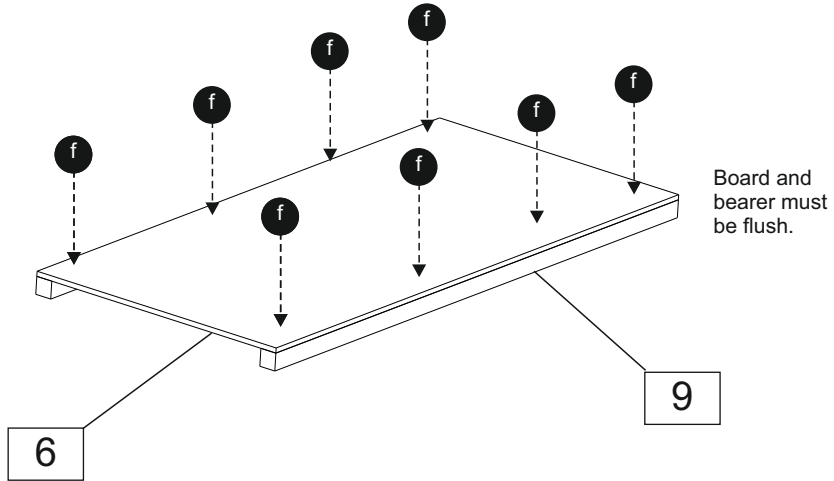
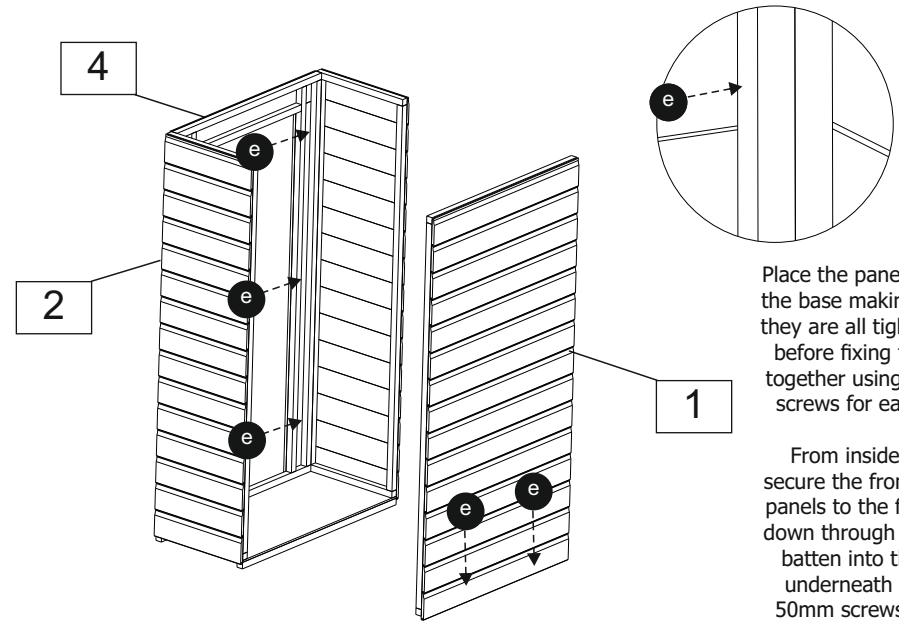
**B**

PRE-DRILL

PRE-DRILL

PRE-DRILL

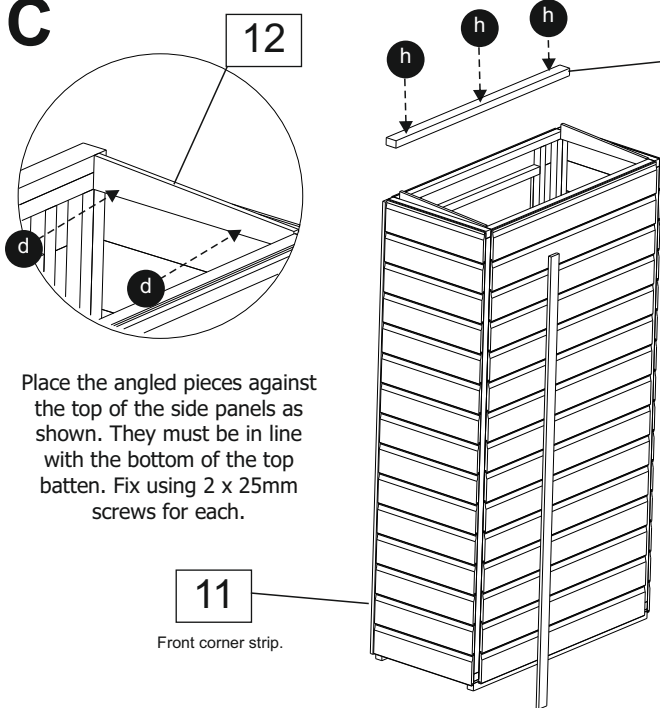
C

Place the batten across the top of the front panel making sure it is flush. Fix it in place using 3 x 60mm screws.

D

Slave Door Assembly

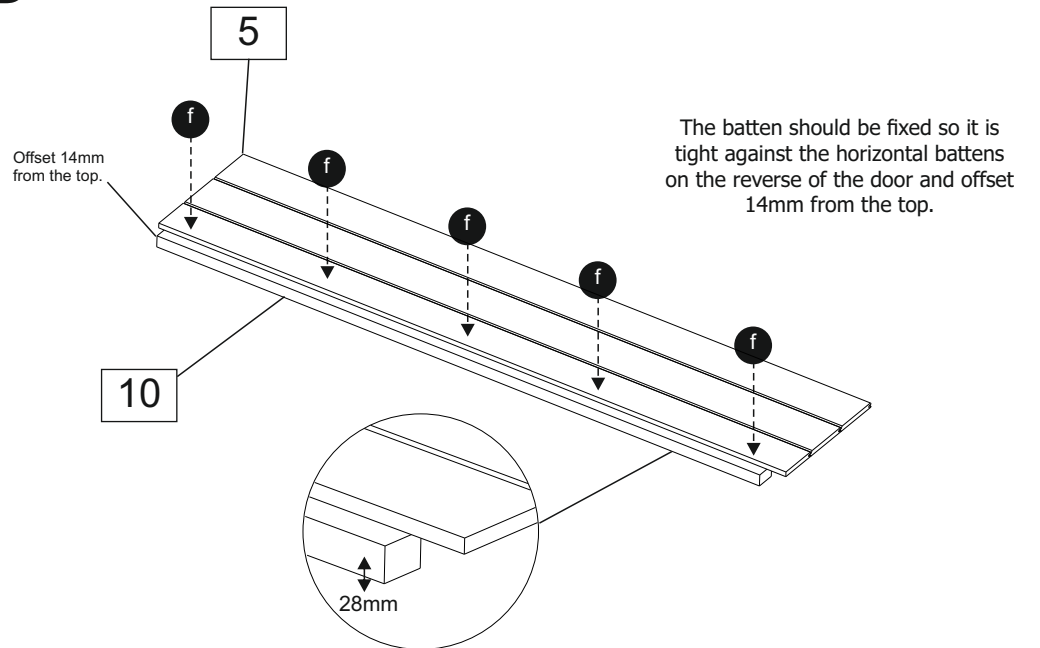
**14**

14 is for the Overlap Garden Store only.

Place each of the corner strips so that they are tight and fix them in place using 4 x nails for each.

E

Place a turn button on the top and bottom of the batten.

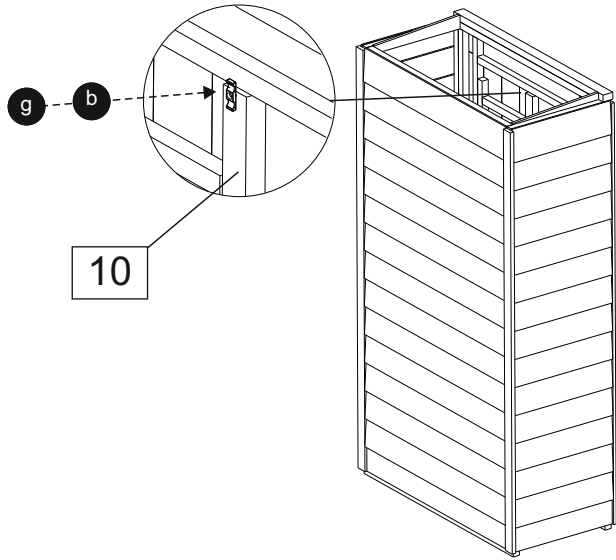

The top of the hinge should be in line with the horizontal batten

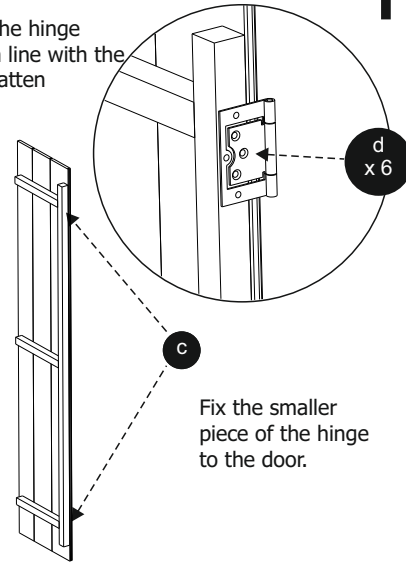
F

Fix the smaller piece of the hinge to the door.

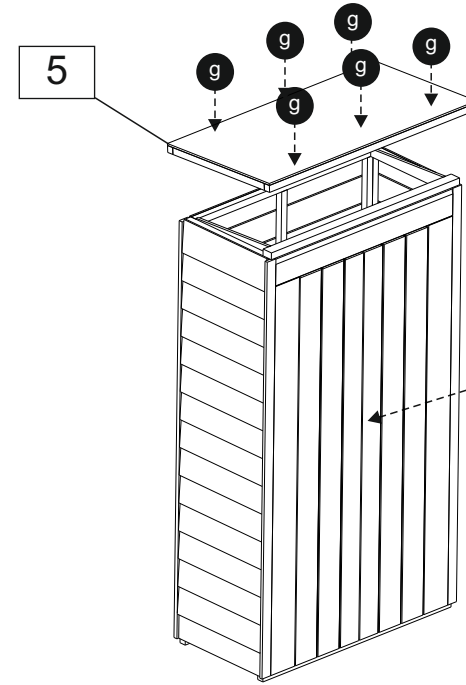

Fix the roof to the Tall Store using 30mm screws.

Position and line up the hasp and staple with framing on the inside of the door.

PRE-DRILL 

PRE-DRILL 

PRE-DRILL 

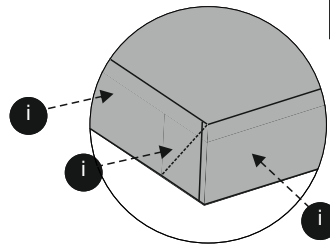
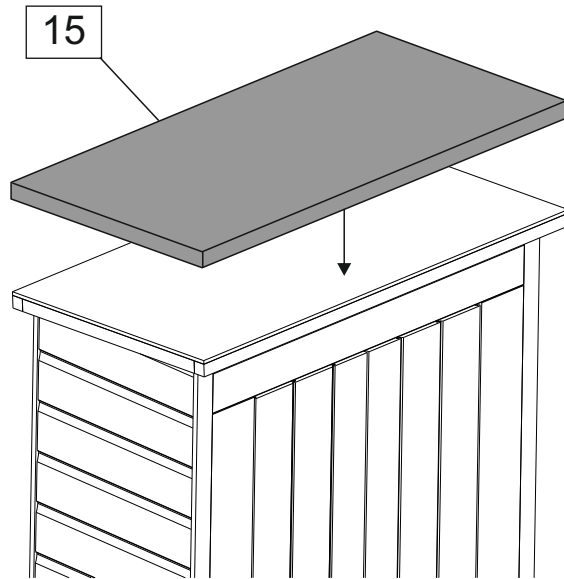
G

Place the felt over the roof so that there is approximately a 45mm overhang on all sides. Secure the felt to the roof, nailing into the battens from the sides using felt tacks placed in 150mm intervals.

Cut and fold the felt at the corners as shown.

Take care when trimming the roof felt.

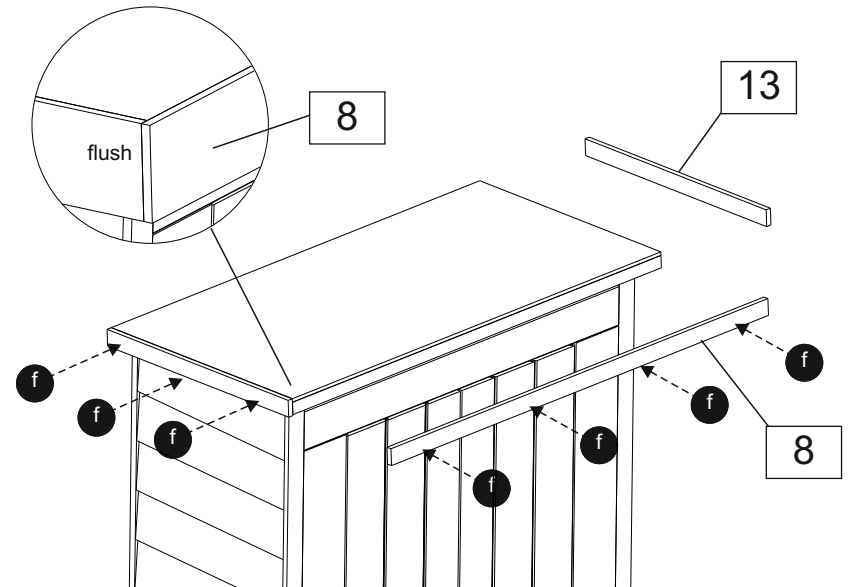
H

Place the barge boards so that they line up at the corners and the top of the roof. Fix each in place using 30mm nails.