

Assembly Instructions

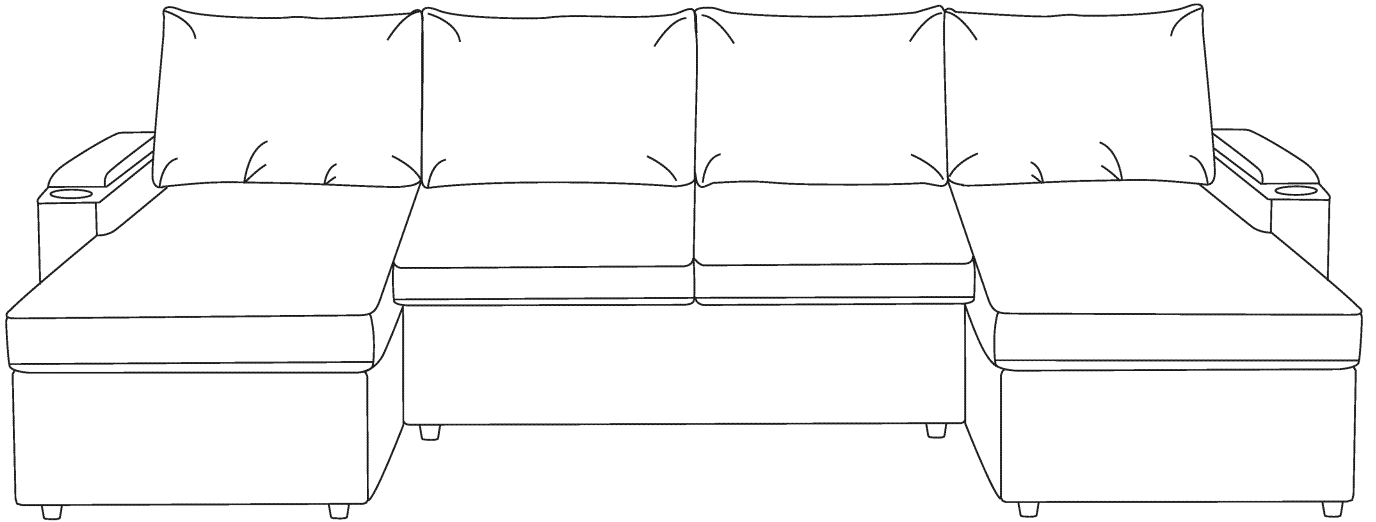

IMPORTANT NOTE

****Place all parts on a lean and smooth surface such as a rug or carpet to avoid the parts from being scratched.**

****Before you begin, please review the assembly instruction step by step.**



****Return & Warranty Policy:**

-We strive to offer the highest quality products. We also provide positive solutions with replacements or refund if needed.



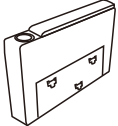
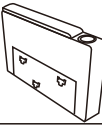

-If the item is damaged or defective, please take photos to show the problem and email to the seller.

-Please do not return back the product before contact the seller.

PART LISTS BOX :

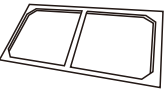
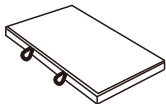
Part NO.	Part Image	Part Name	QTY
①		Left Armrest	1
②		Right Armrest	1
③		Back cushion	2

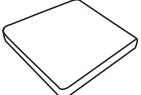
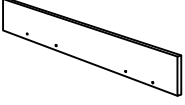
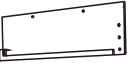
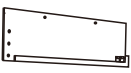
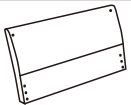
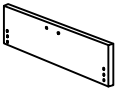

PART LISTS BOX :

Part NO.	Part Image	Part Name	QTY
④		2way Seat board	1
⑤		Pull bed board	1
③		Back cushion	2
⑥		Seat cushion	2
⑦		Pull bed Front board	1
⑧		2way left board	1
⑨		2way Right board	1
⑩		2way Backrest	1
⑪		Chaise front backrest	2
⑳		Leg	16

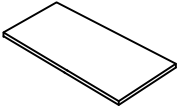
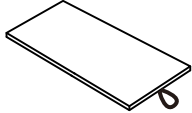
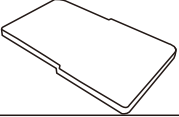
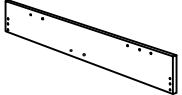
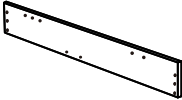
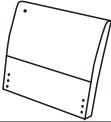
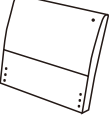
PART LISTS BOX :

Part NO.	Part Image	Part Name	QTY
⑫		Chaise Base board	1
⑬		Chaise Seat board	1
⑭		Seat cushion	1
⑮		Left Chaise Left board	1
⑯		Left Chaise Right board	1
⑰		Right Chaise Backrest	1
⑲		Left Chaise Backrest	1

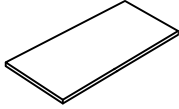
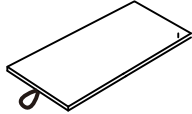
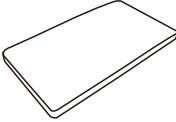
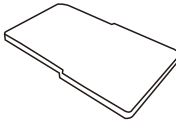
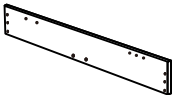
PART LISTS BOX :





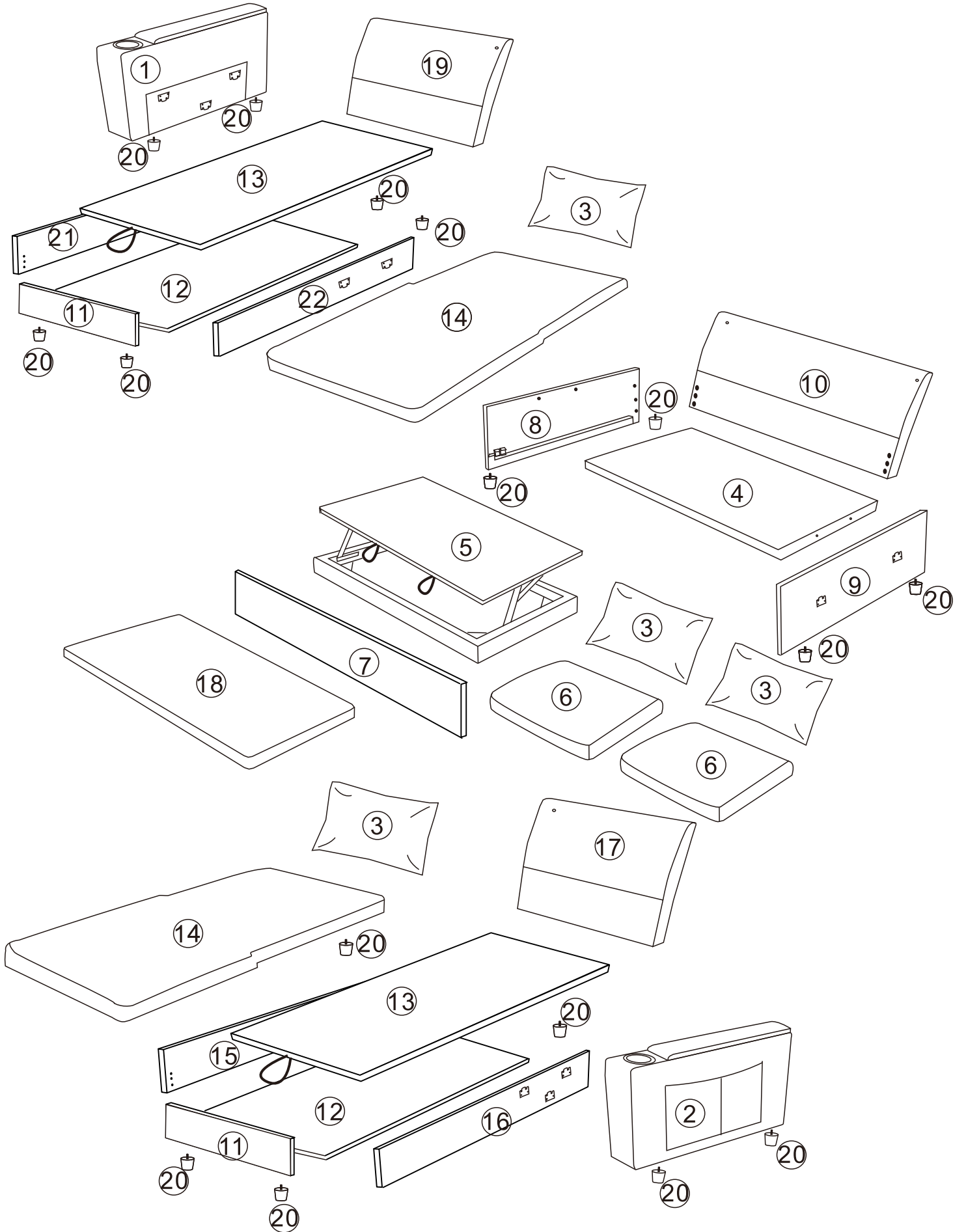





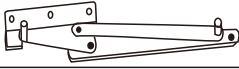

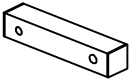
Part NO.	Part Image	Part Name	QTY
⑫		Chaise Base board	1
⑬		Chaise Seat board	1
⑱		2way Seat cushion	1
⑭		Seat cushion	1
㉑		Right Chaise Left board	1
㉒		Right Chaise Right board	1

Sofa Overall Assembly Drawing

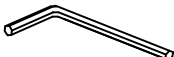

Hardware List

PART LISTS BOX :

Part NO.	Part Image	Part Name	QTY
A		chaise connector	4
B		Spring	4
C		Angle code	10
D		Square tube	10
E		connector	2
F		Casters	4
G		M6*18mm Bolt	60
H		M6*20mm Bolt	28
I		M6*35mm Bolt	20
J		M6*40mm Bolt	4
K		M6*60mm Bolt	4
L		Flat washer	112
M		Allen Key	1
N		M6*25mm Bolt	4
O		Adapter	1

step:1

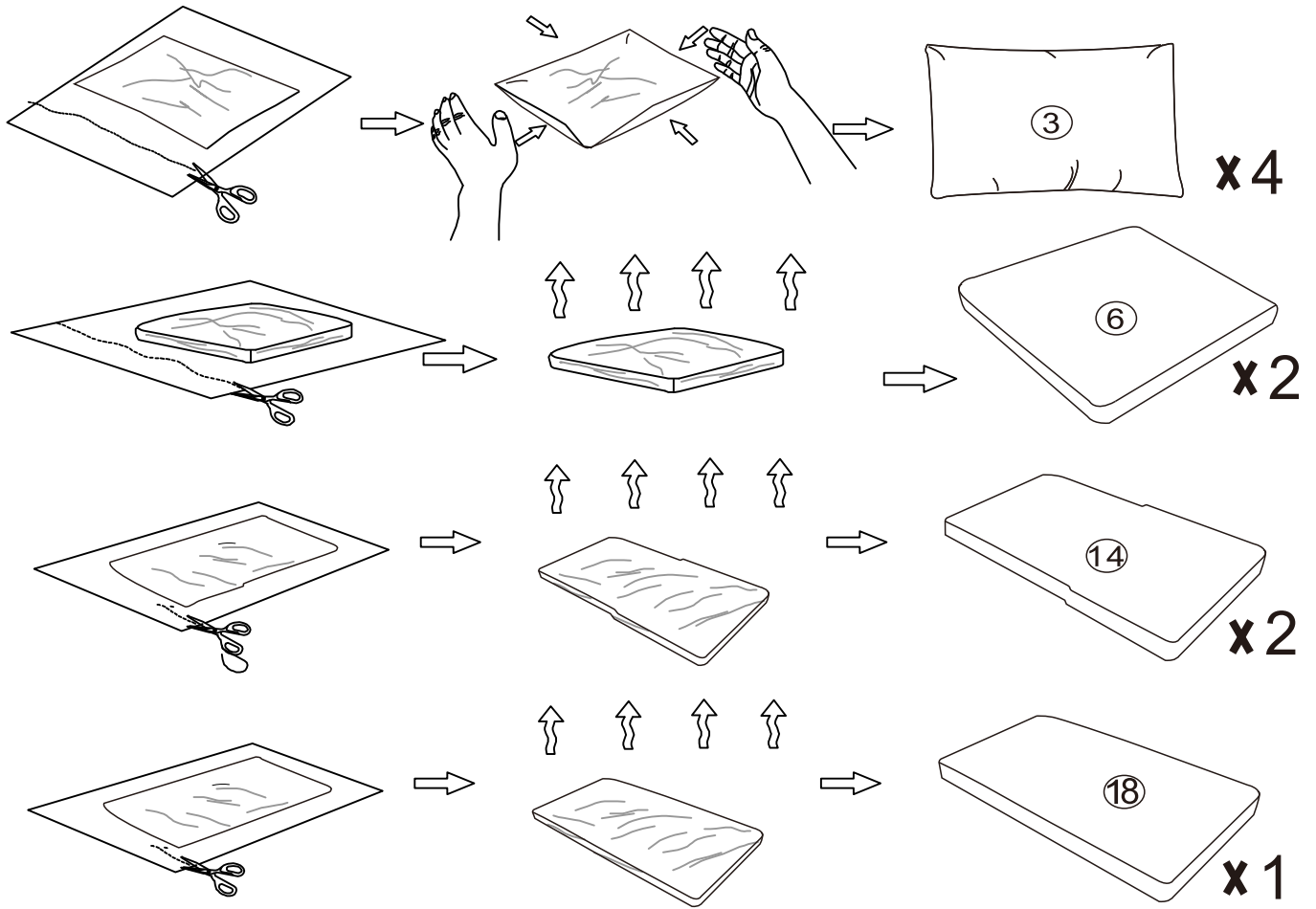

step:2

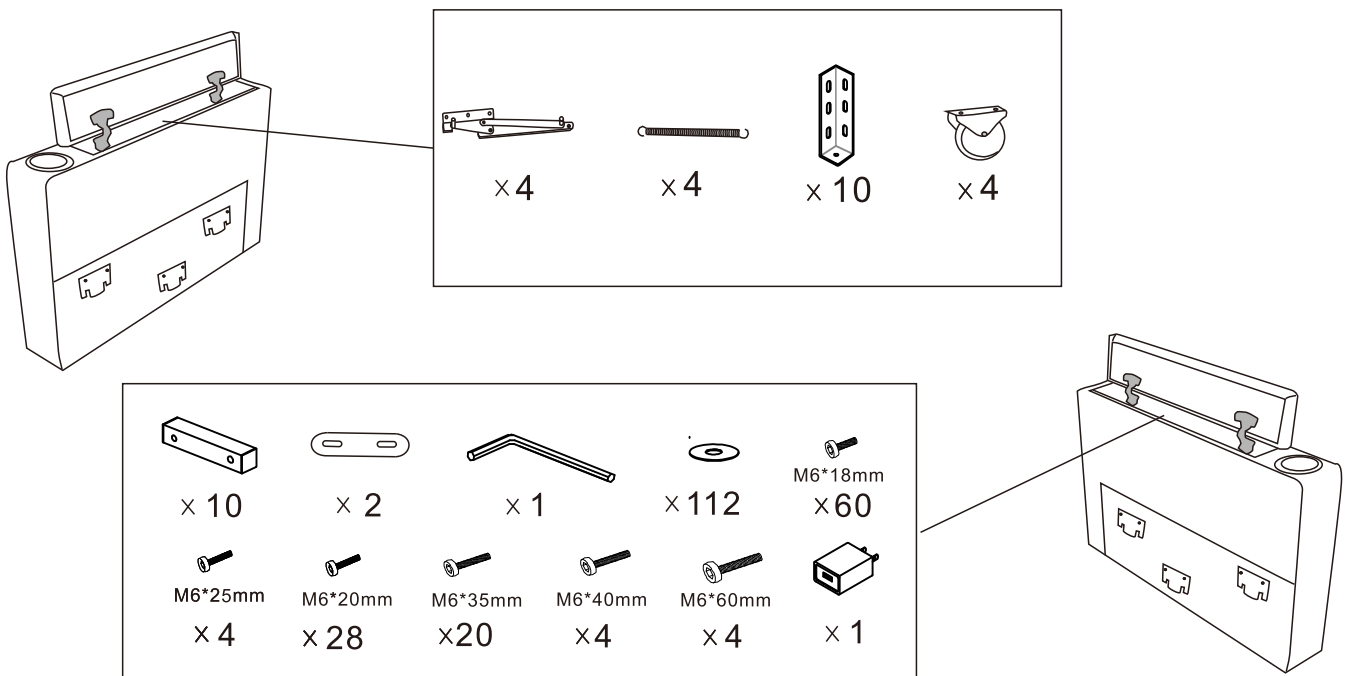

step:3

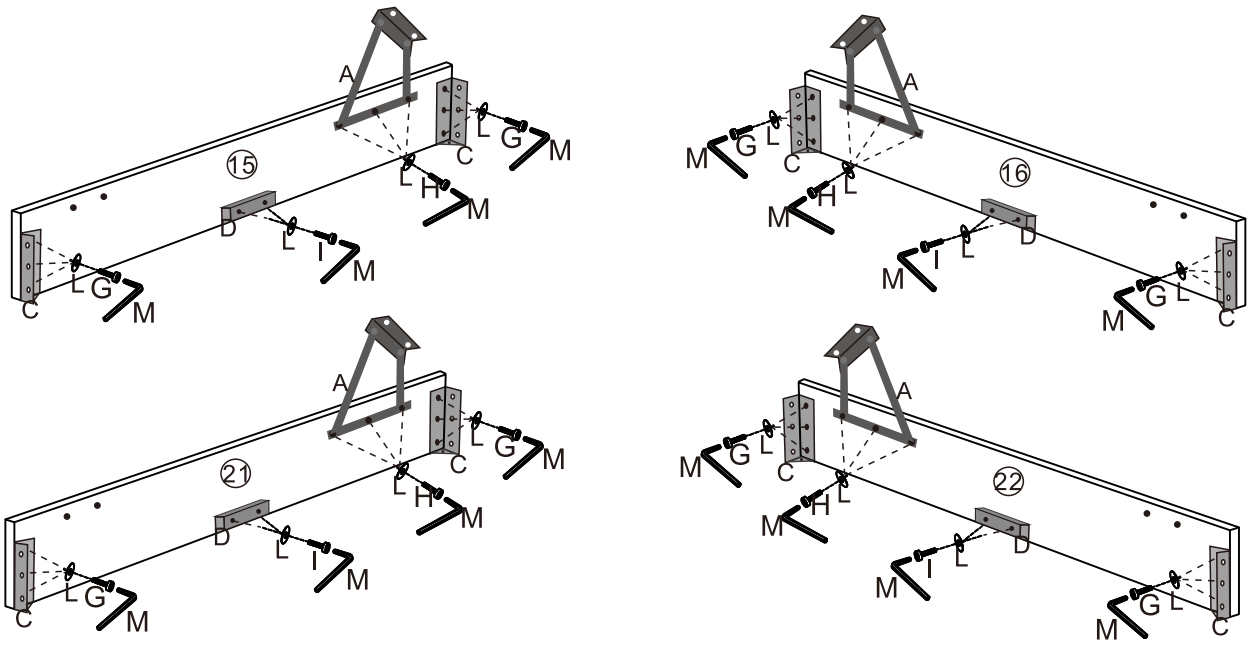

M × 1	G × 24	H × 12	I × 8	L × 44	C × 8	D × 4	A × 4
	M6*18mm	M6*20mm	M6*35mm				

step:4

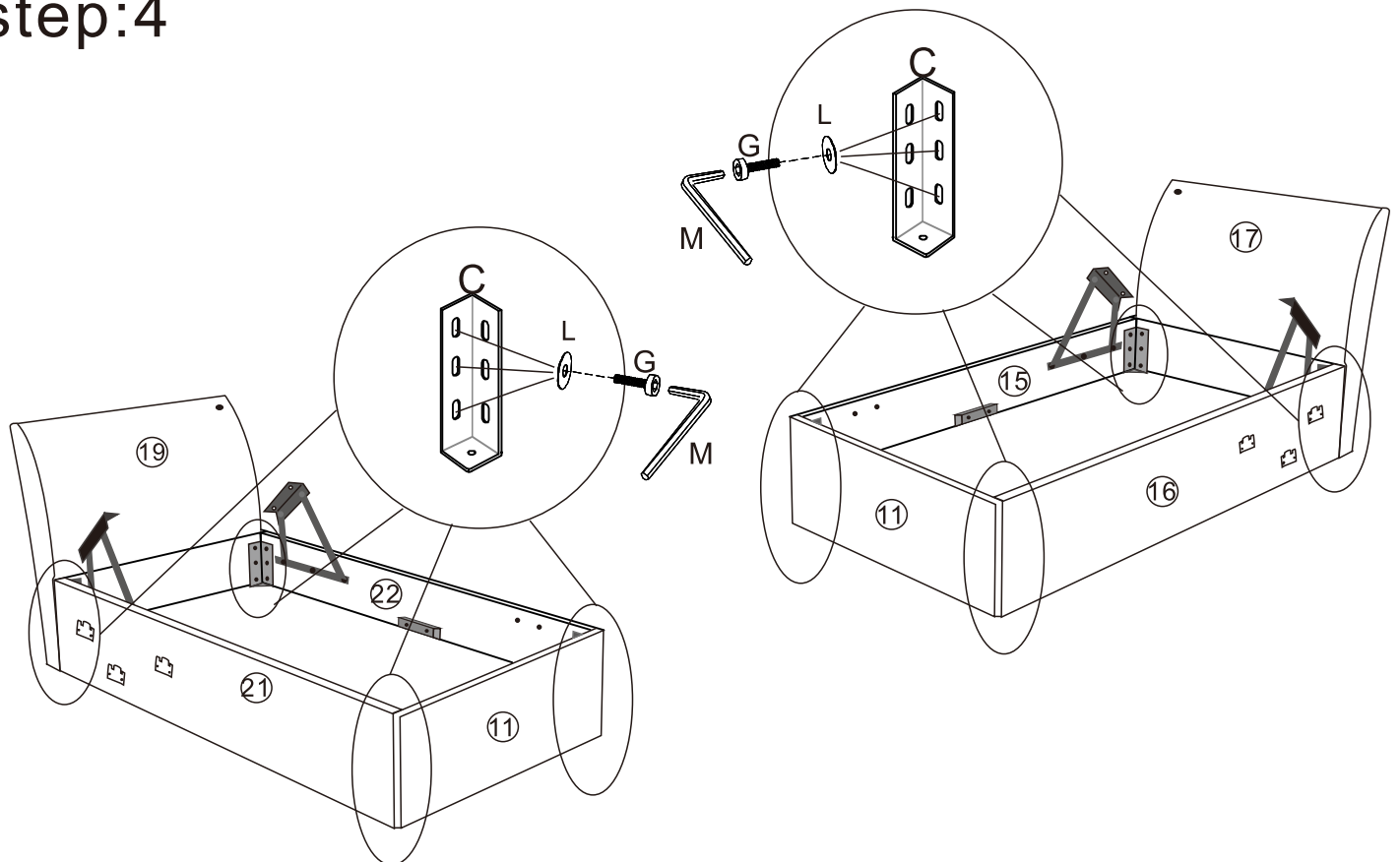

M × 1	G × 24	L × 24
	M6*18mm	

step:5

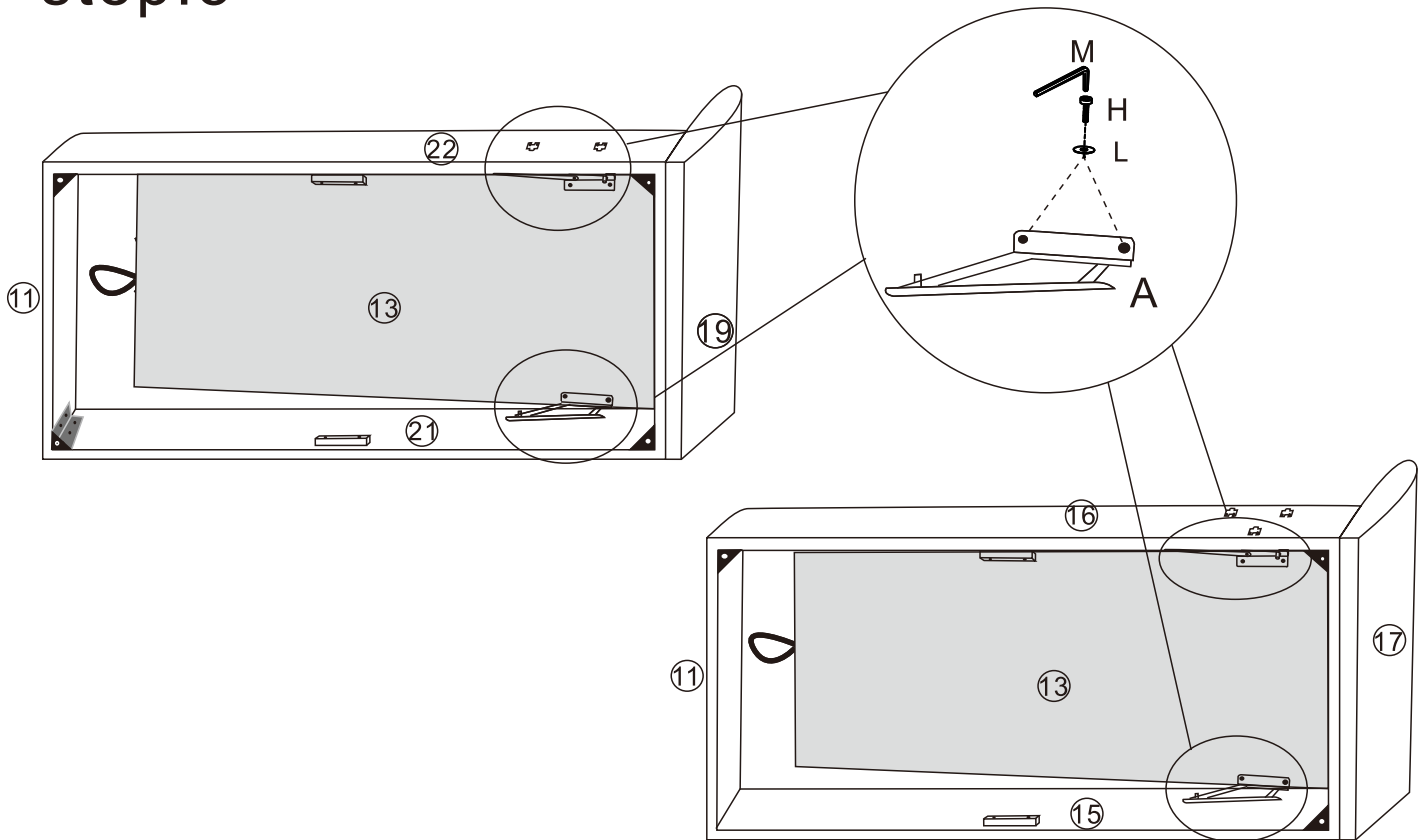

M×1	H×8	L×8
	M6*20mm	

step:6

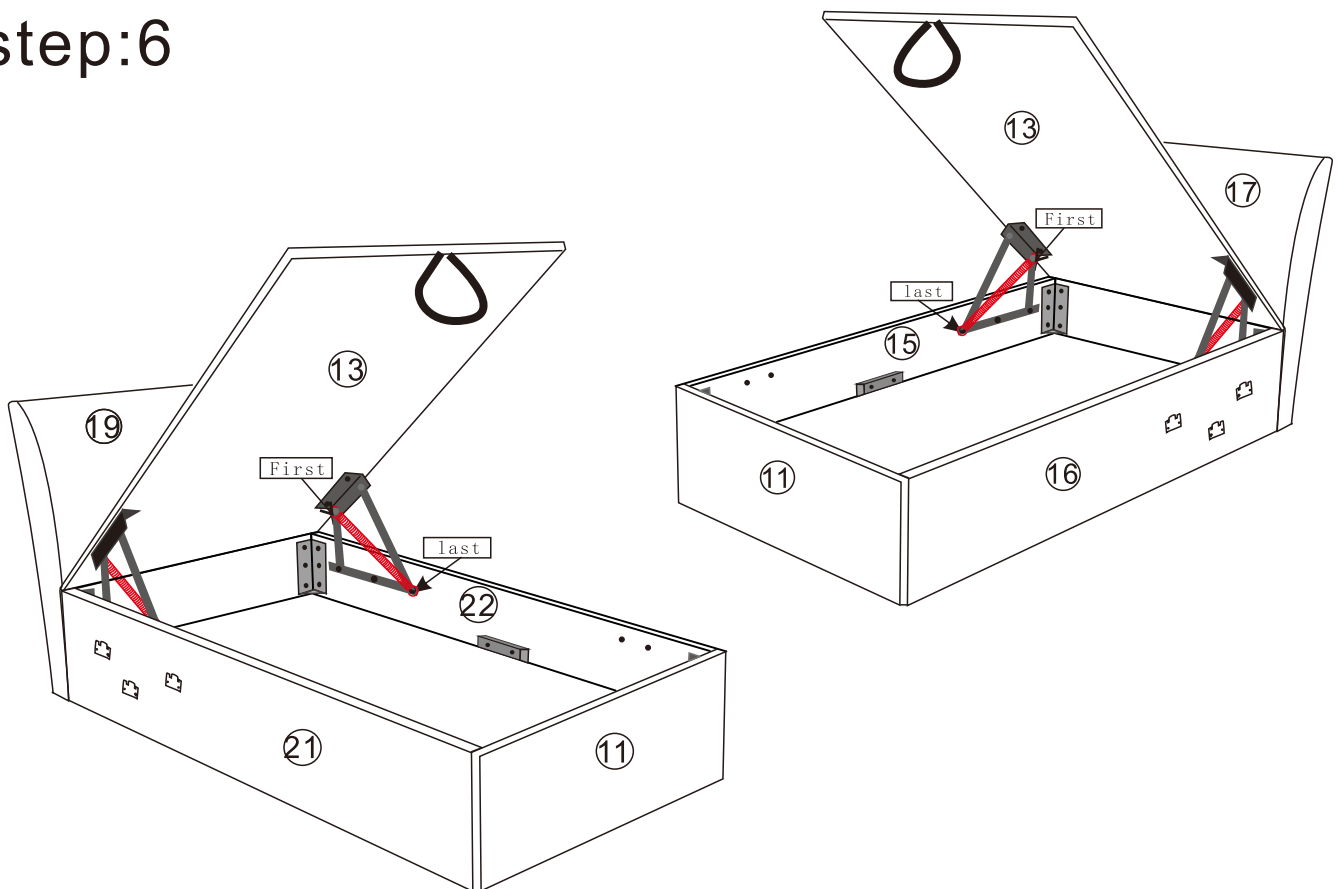

B×4

step:9

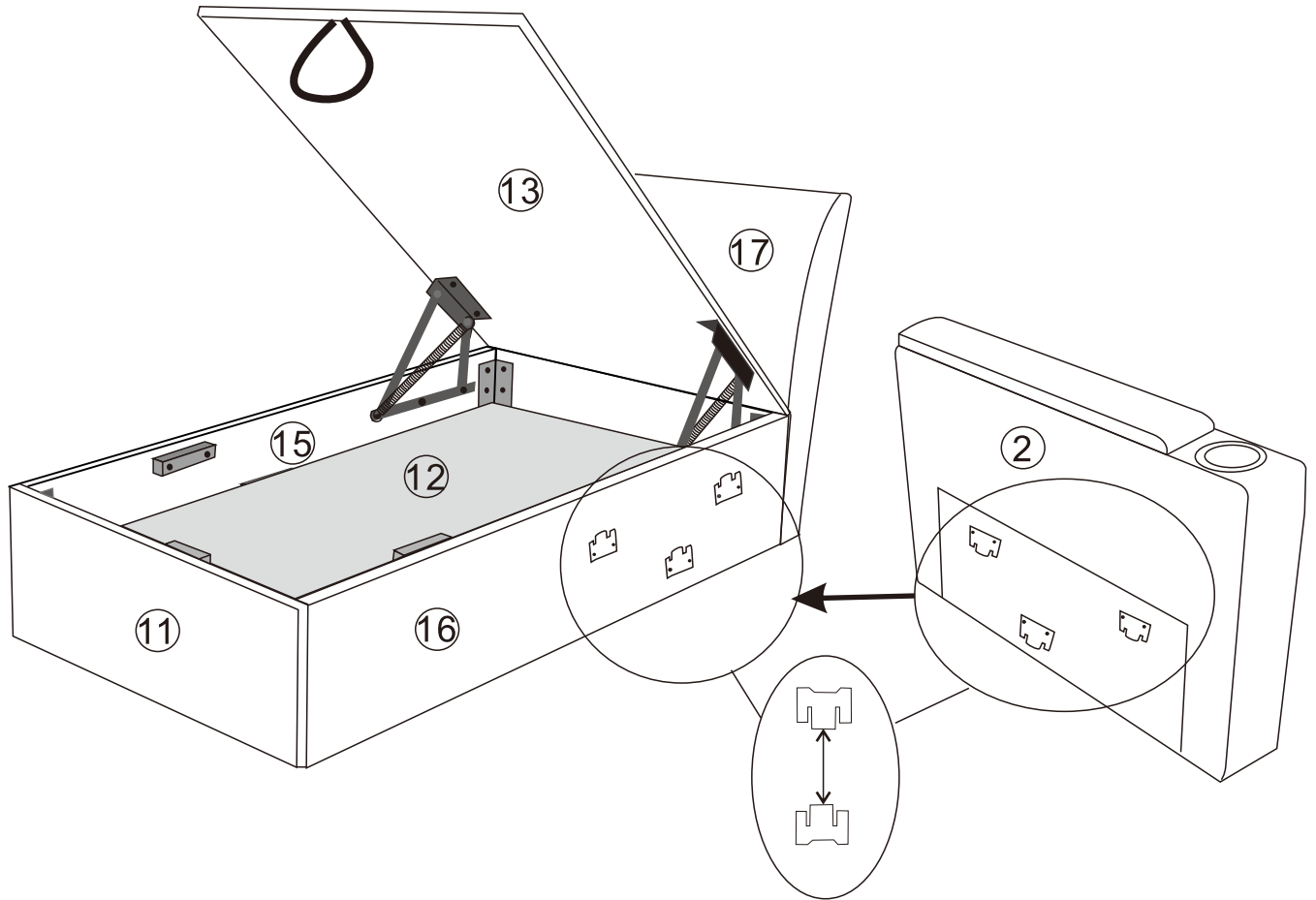

step:10

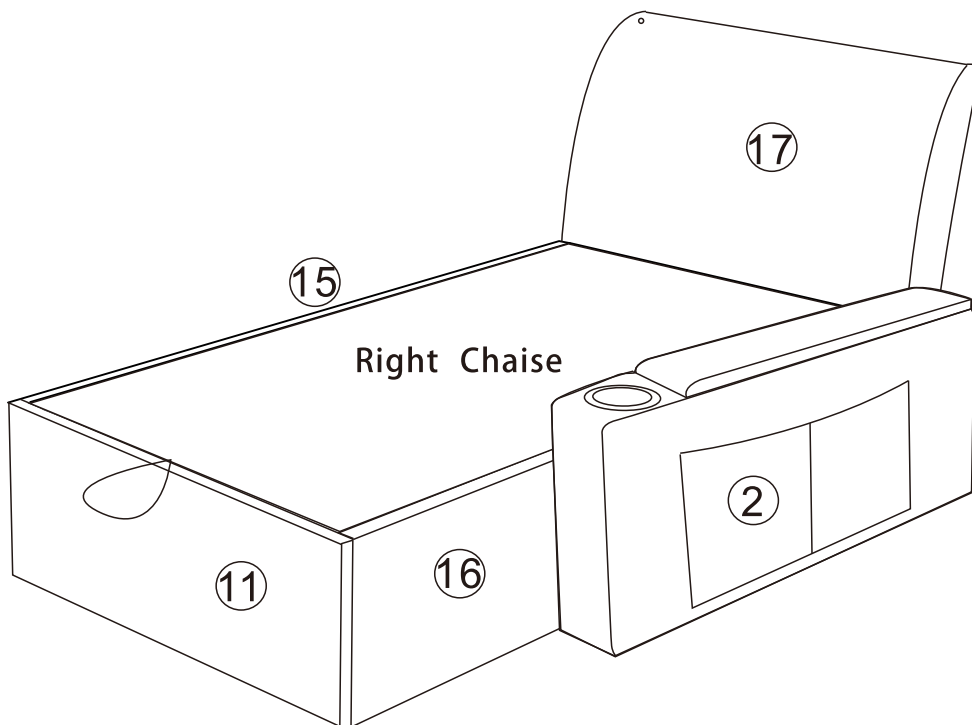

step:11

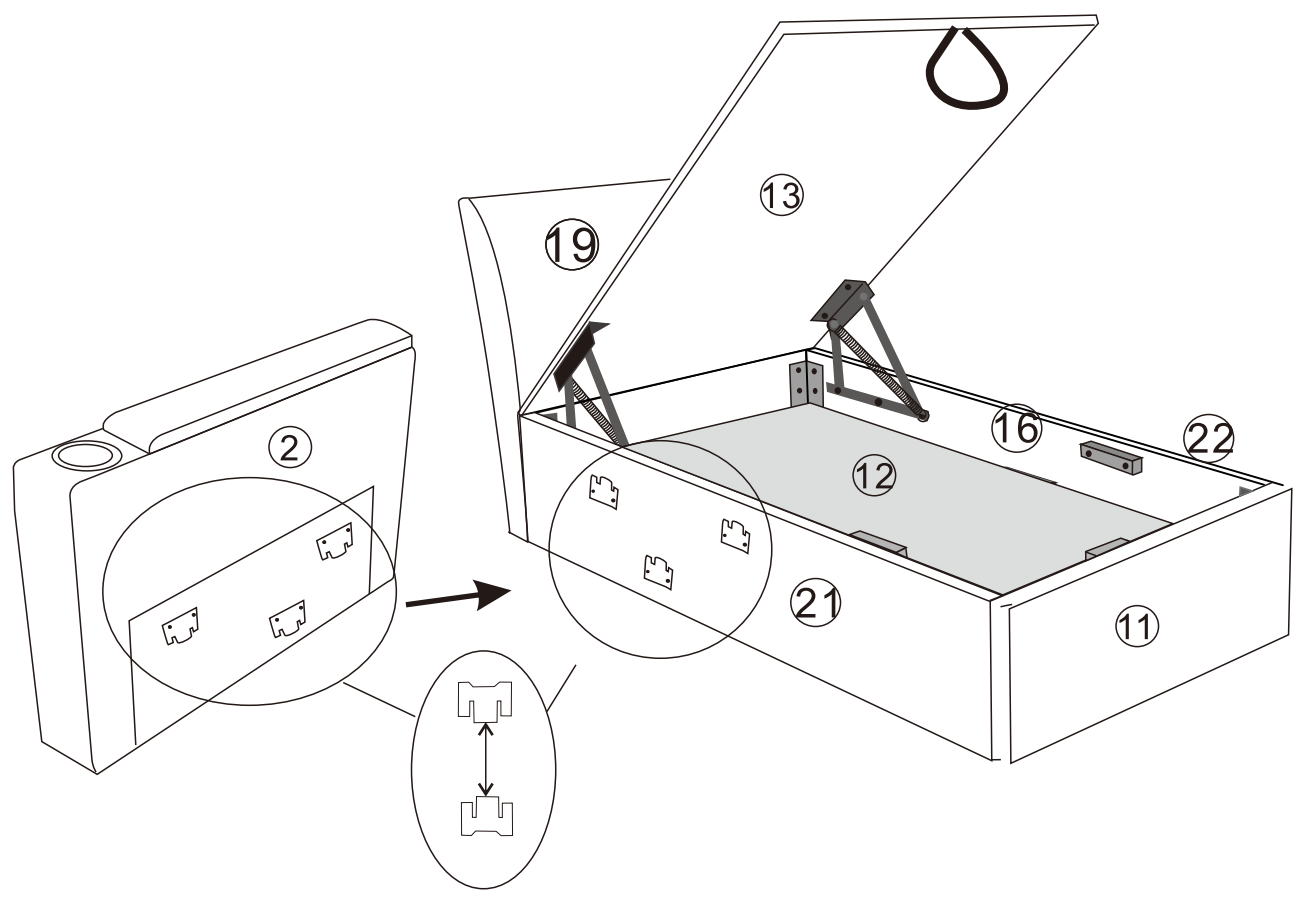

step:12

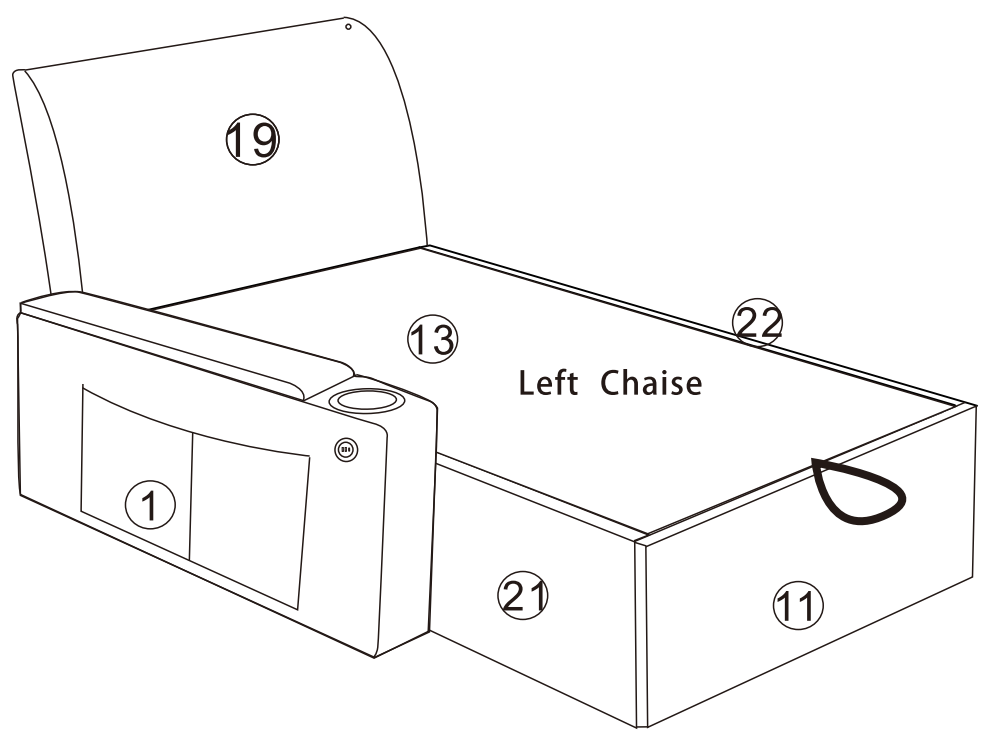

step:13

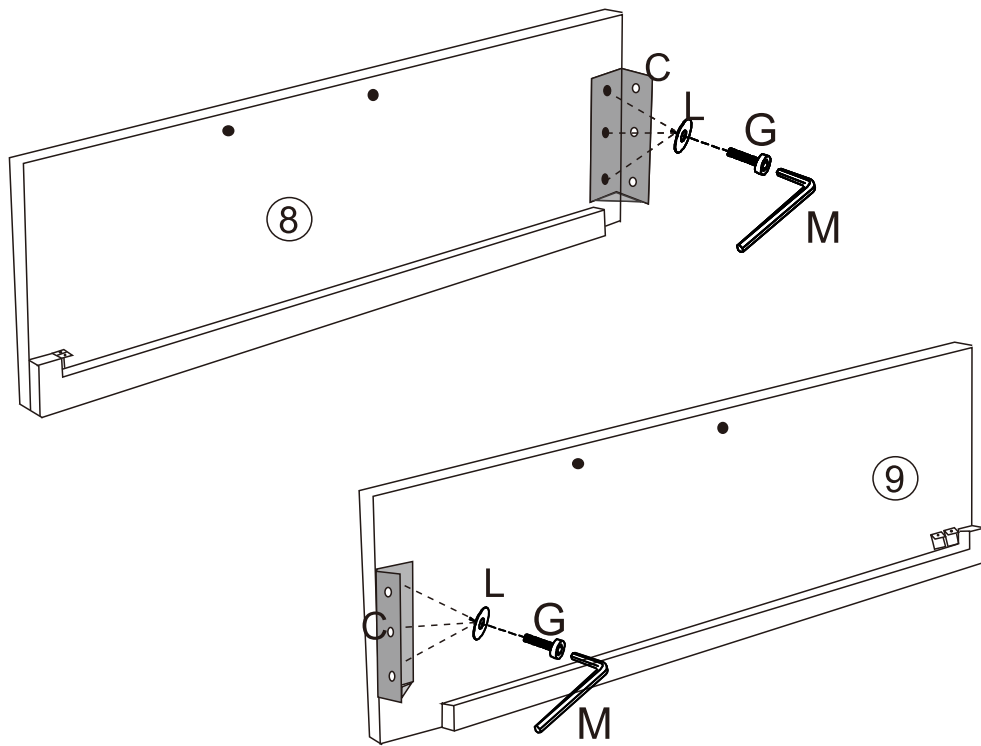

M × 1	G × 6 M6*18mm	L × 6	C × 2

step:14

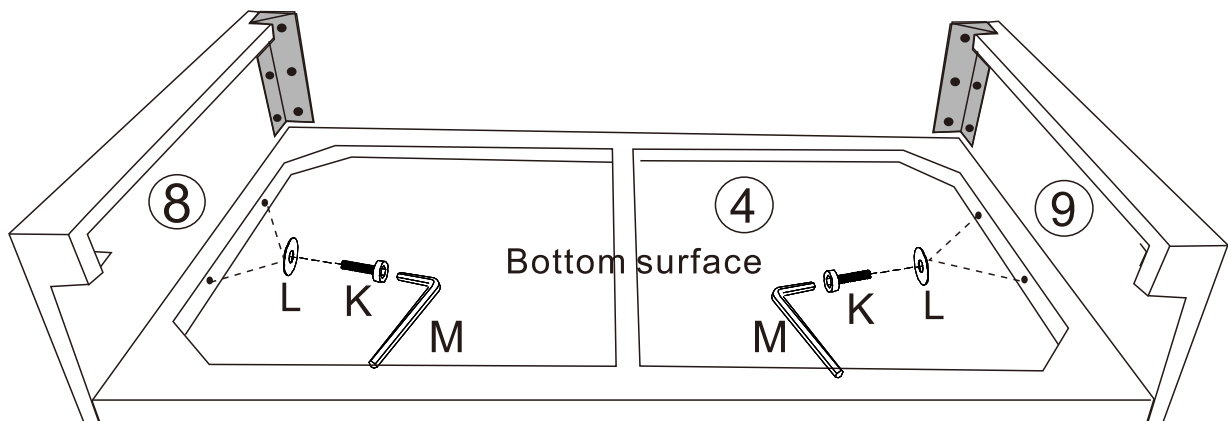

M × 1	K × 4	L × 4
	M6*60mm	

step:15

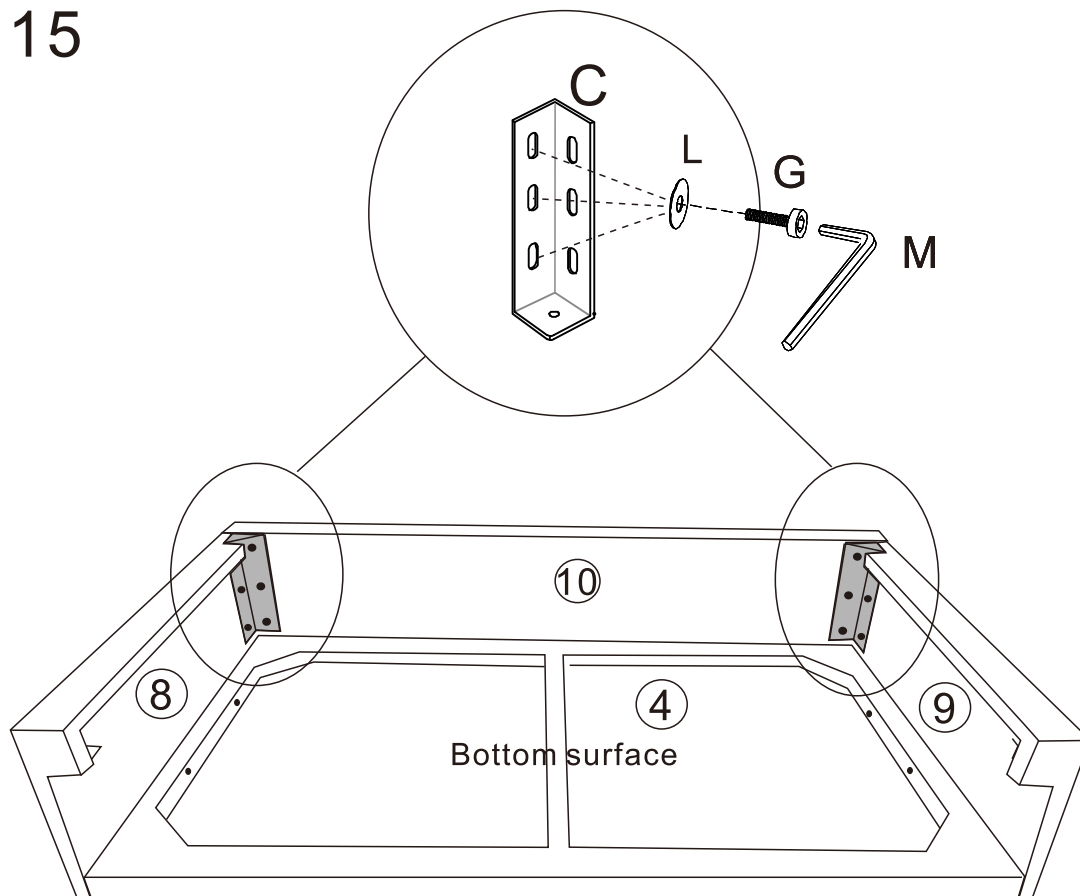

Mx1	Gx6	Lx6	Cx2
	 M6*18mm		

step:16

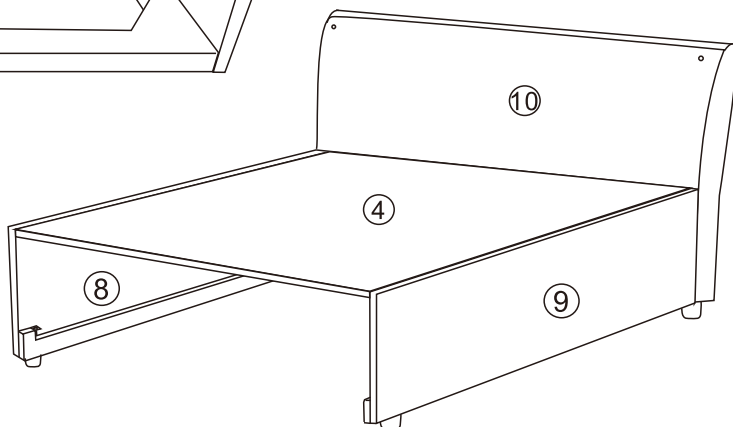
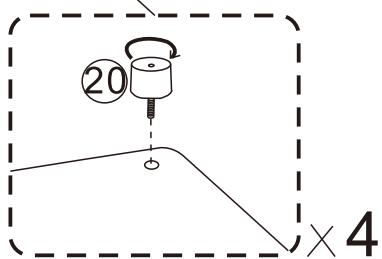
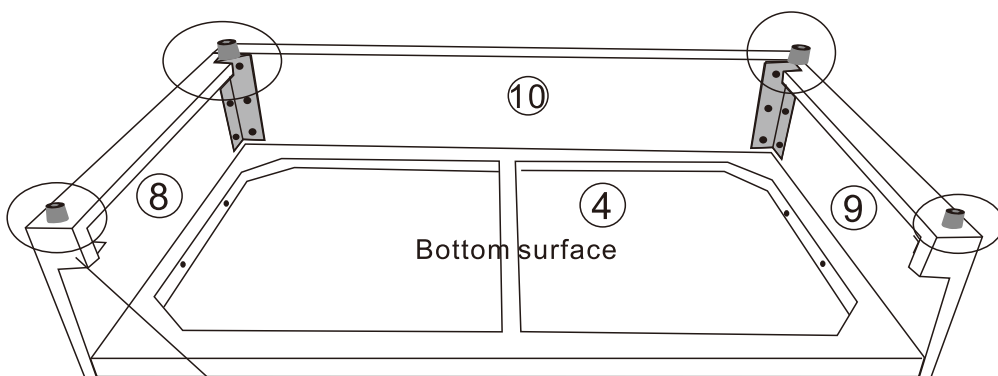

step:17

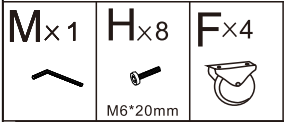
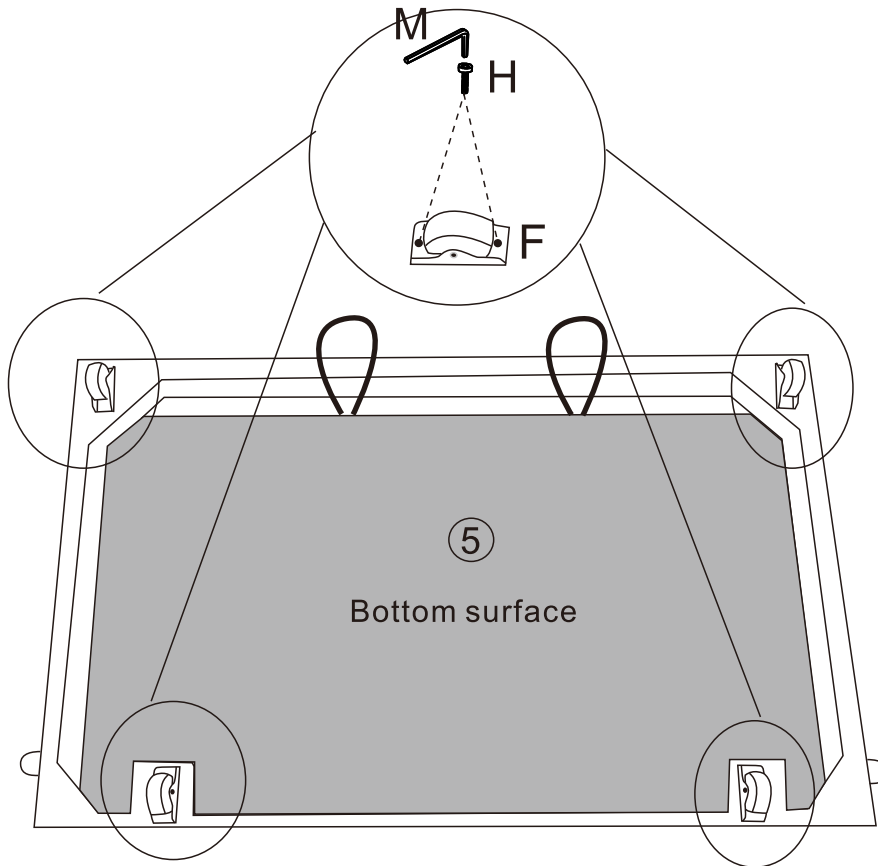

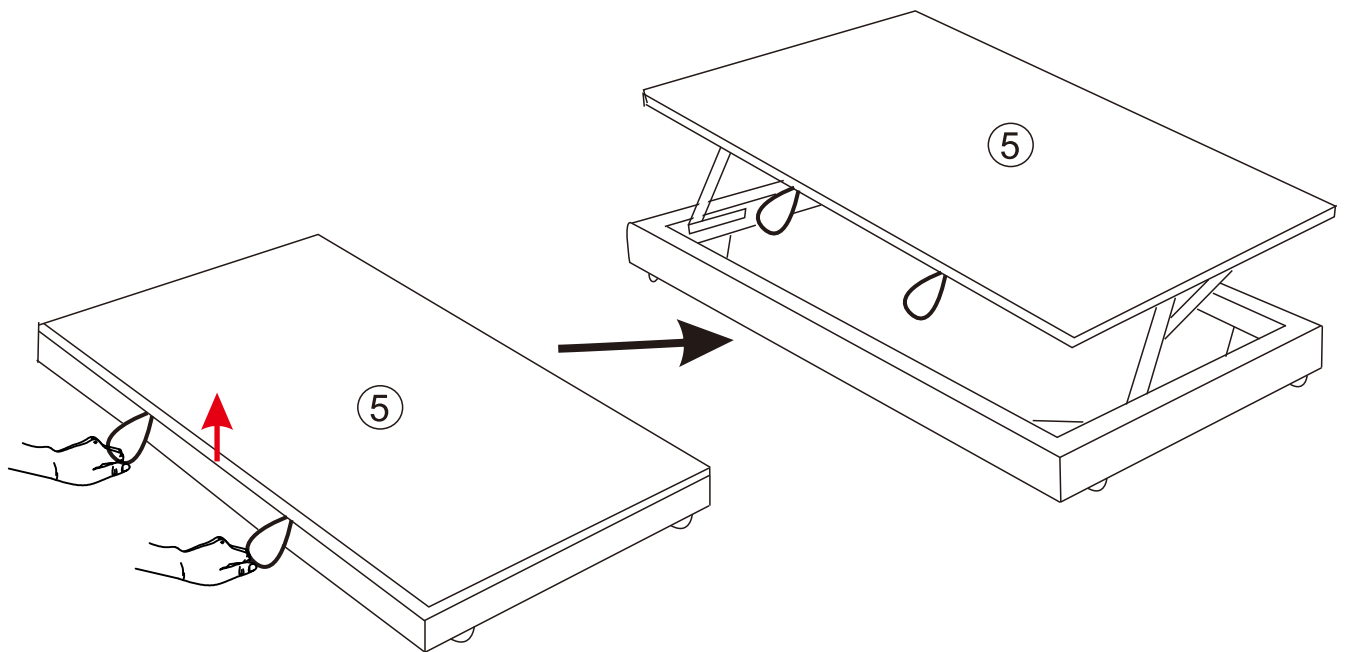

step:18

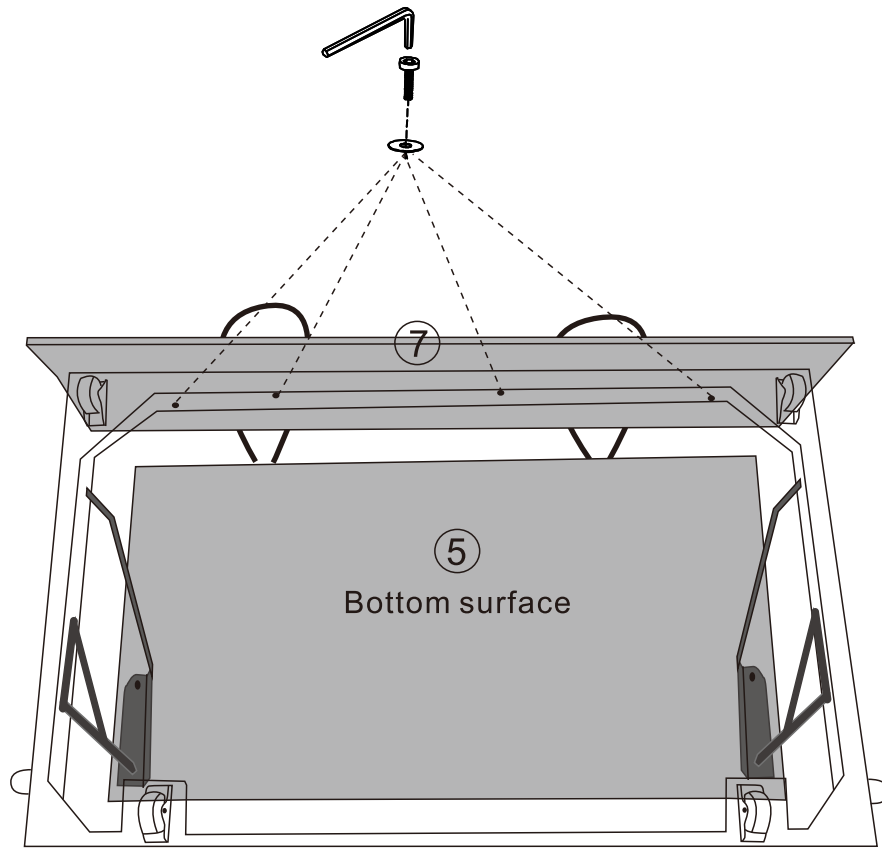

step:19



M×1	J×4	L×4
	 M6*40mm	

step:20

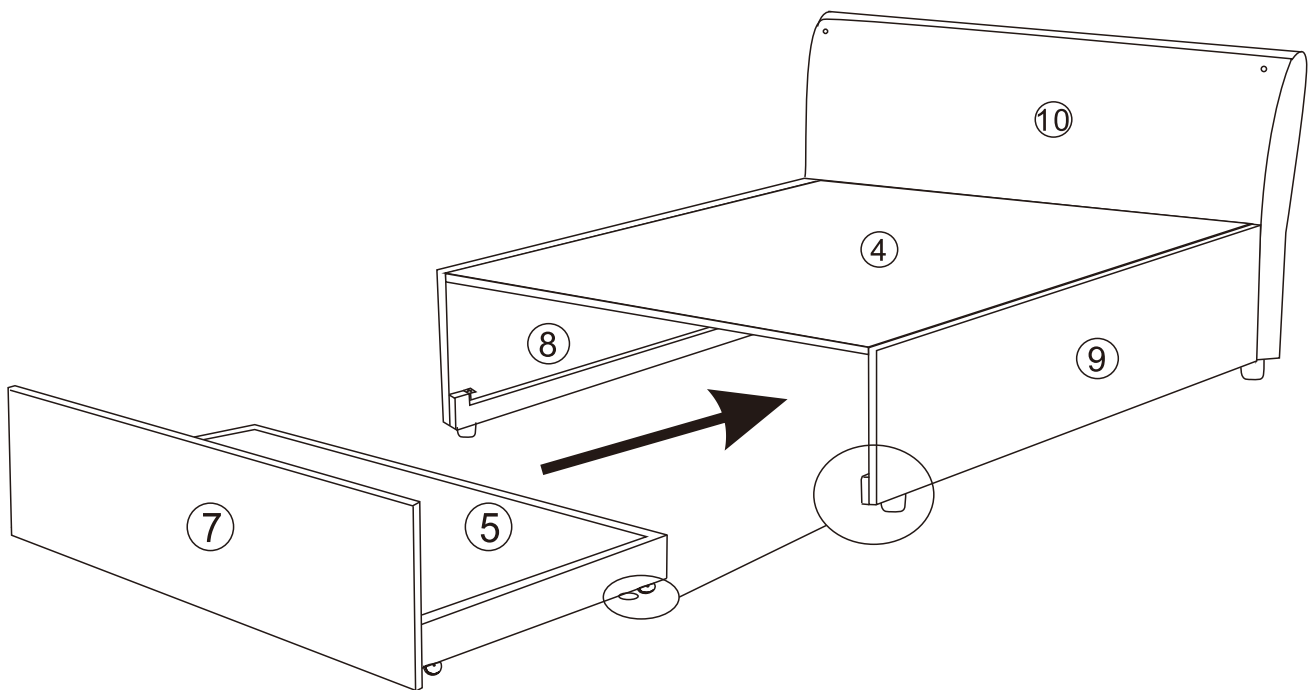

step:25

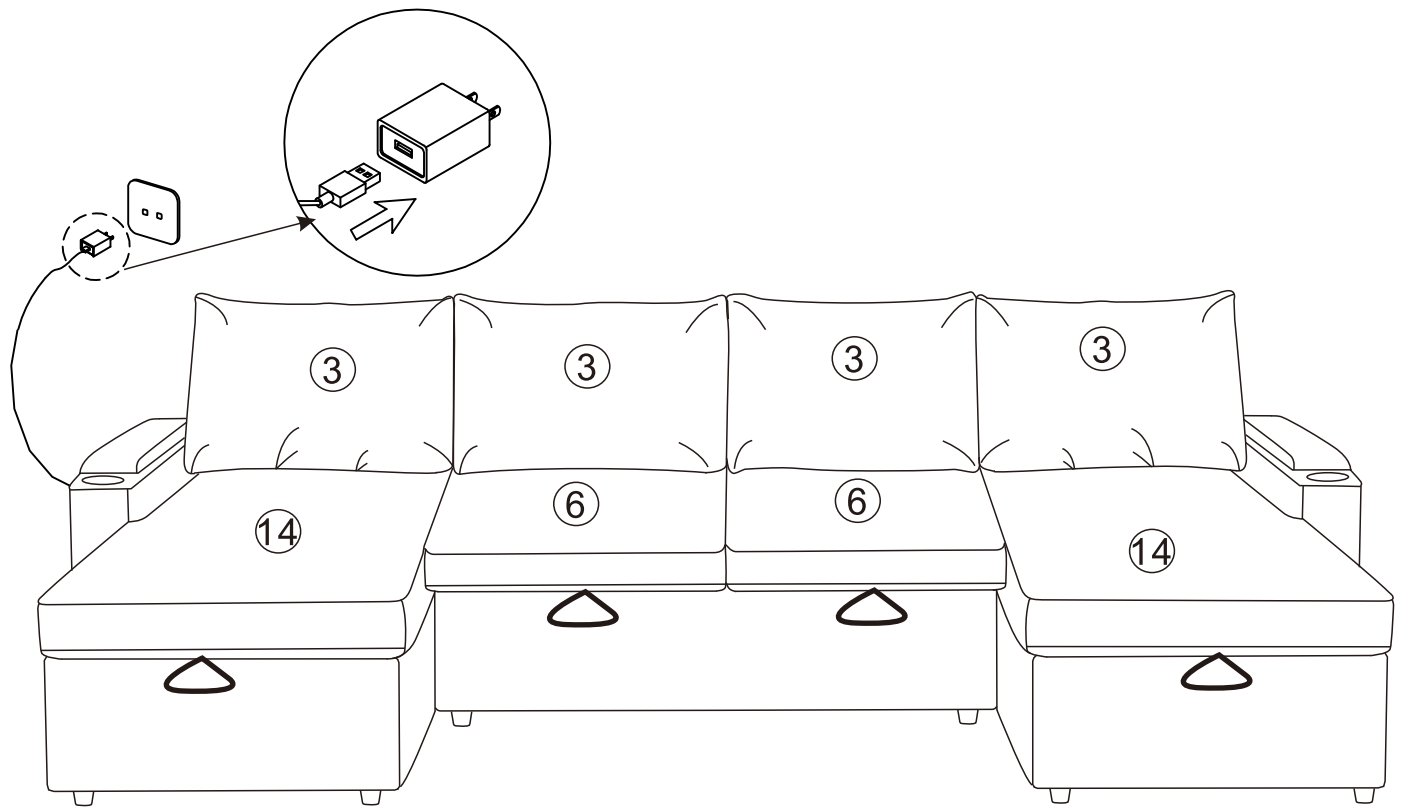

step:26

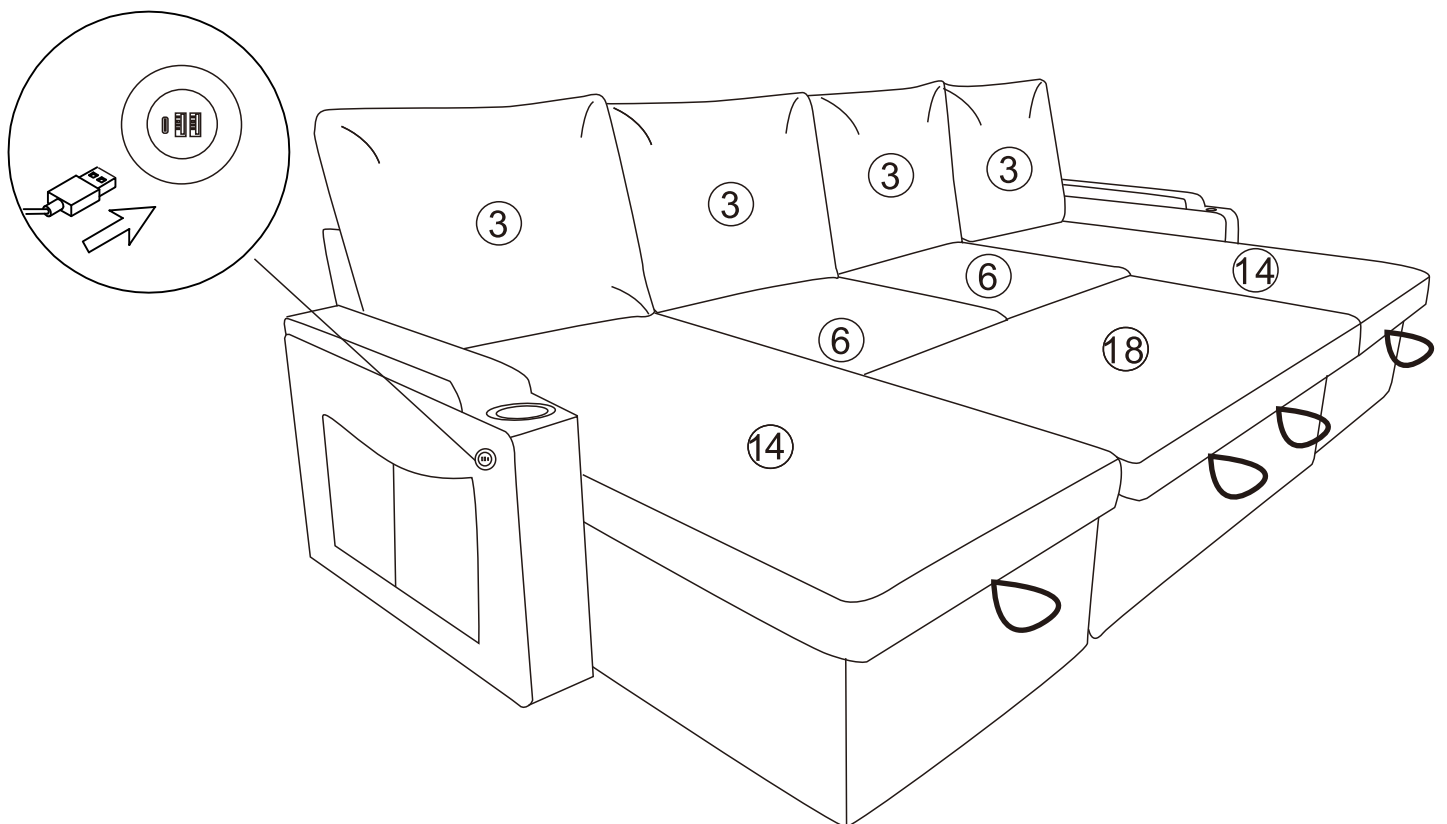

step:27

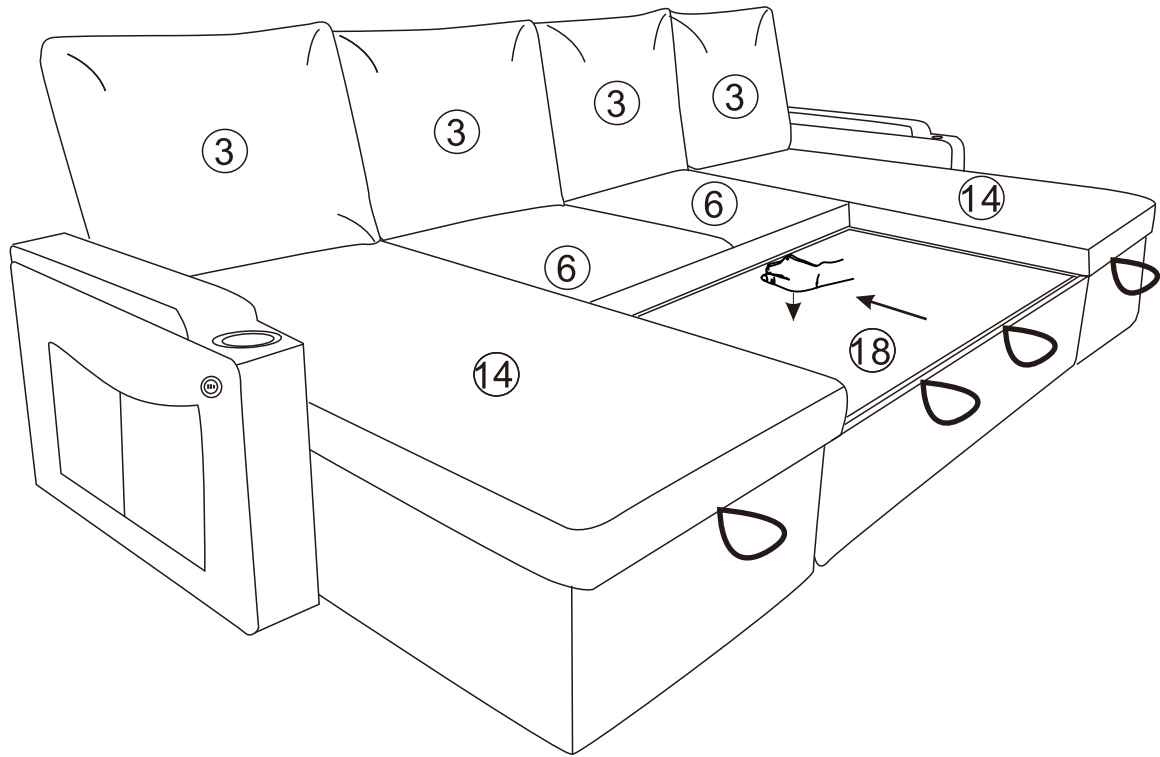

step:28

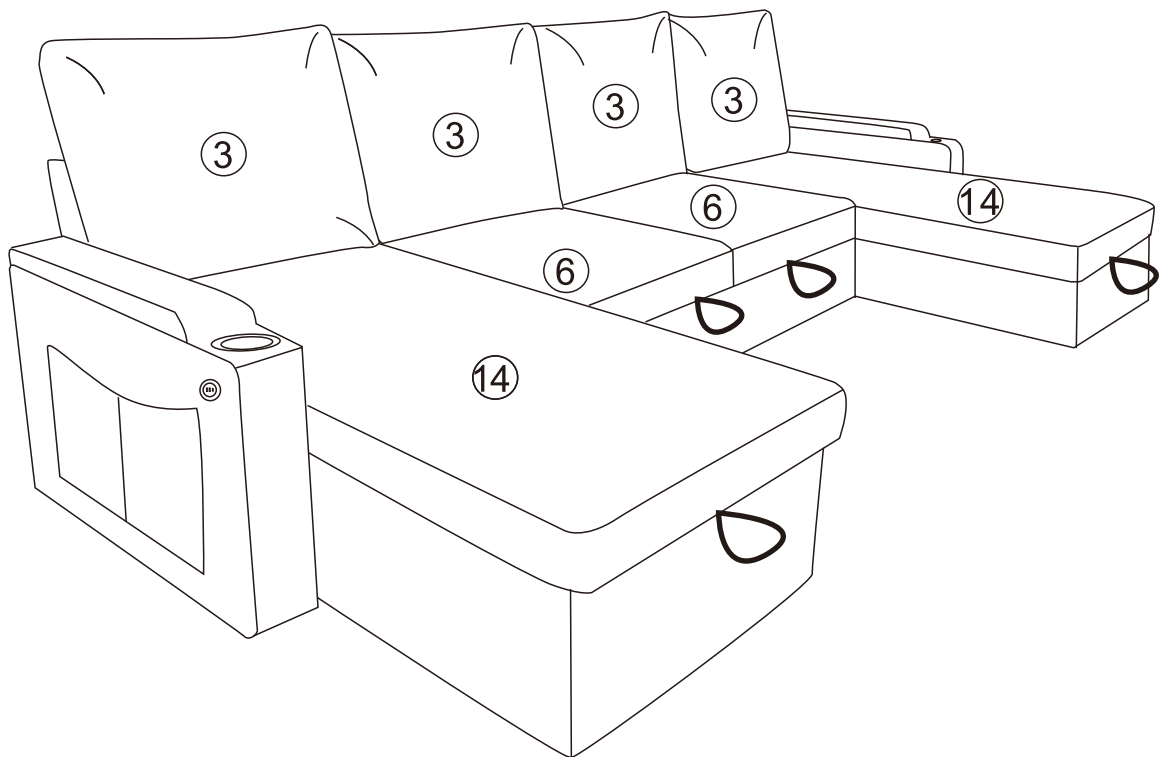

18