

WF322150
WF322151

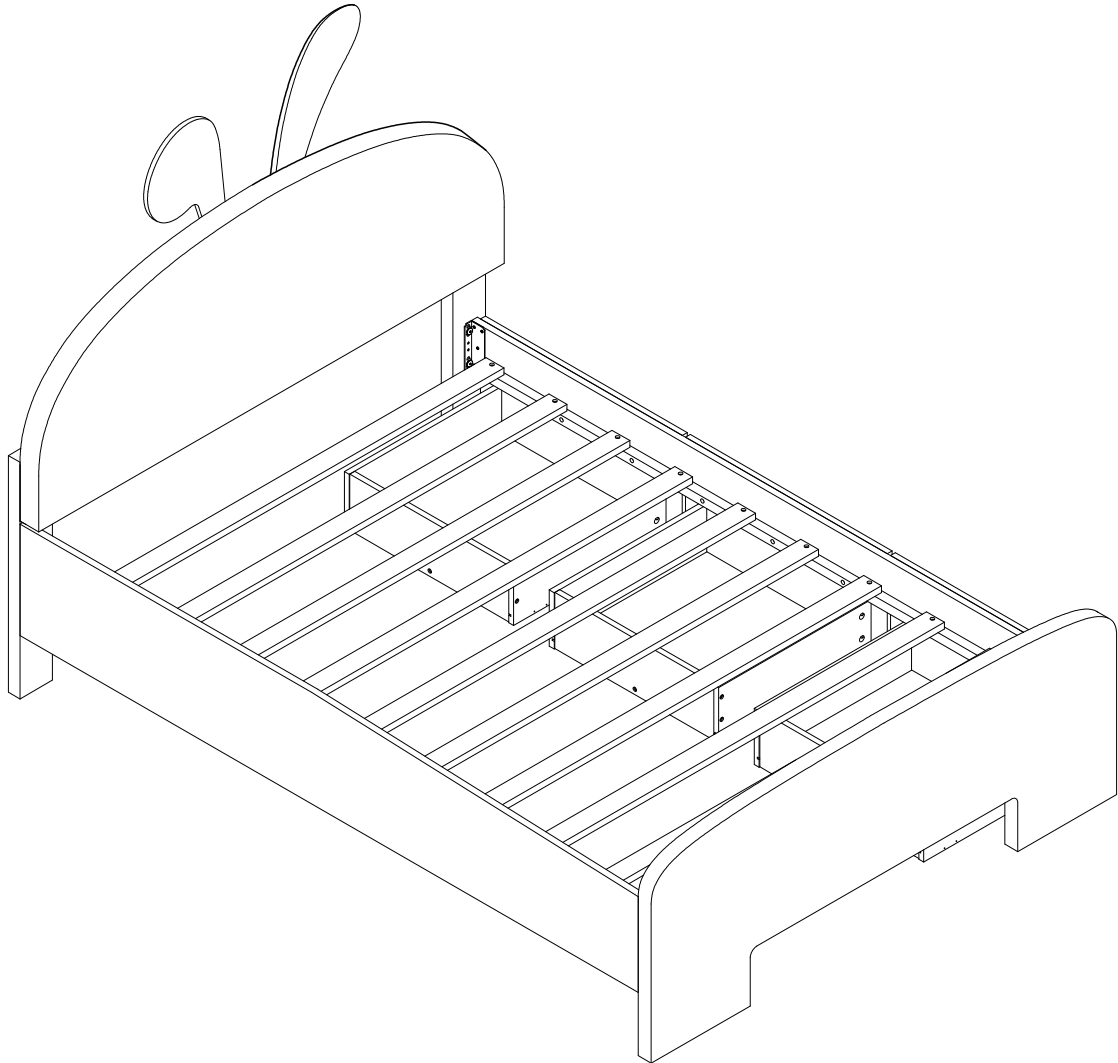

ASSEMBLY INSTRUCTIONS

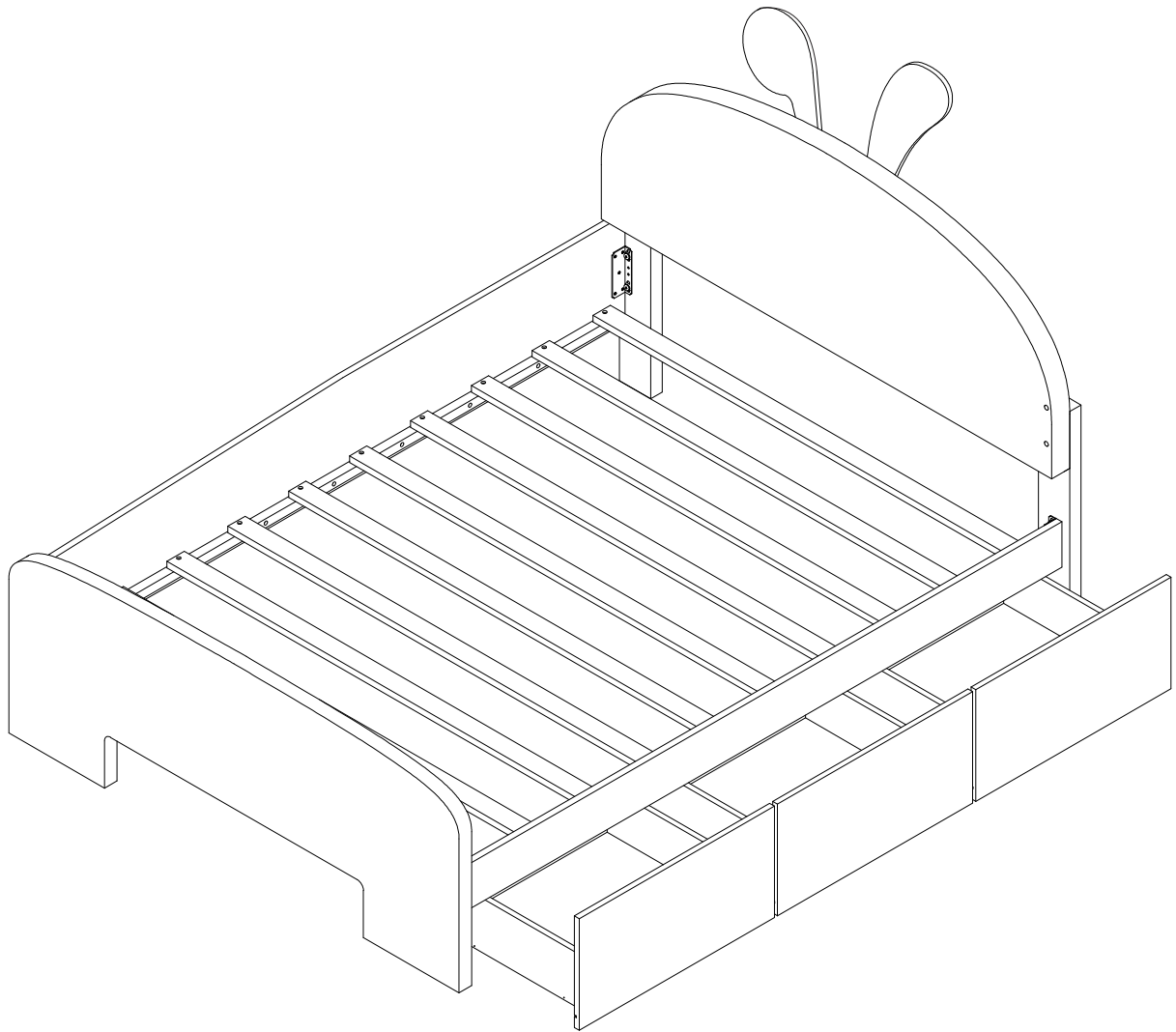

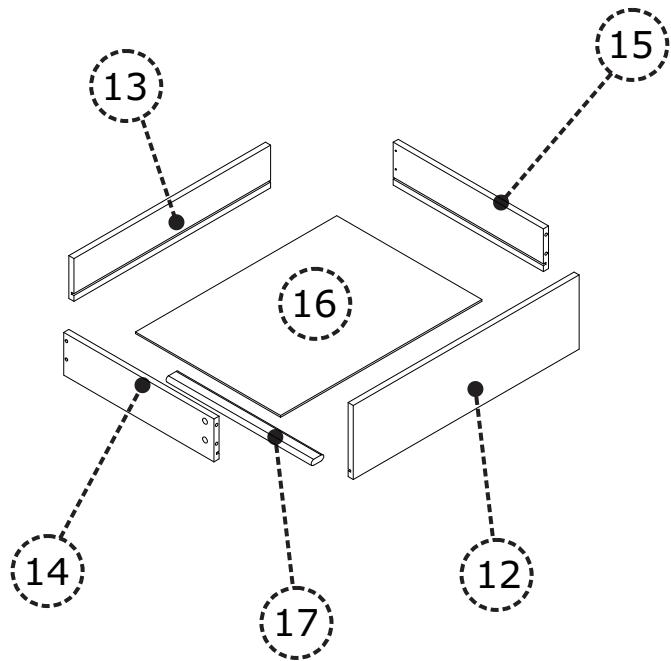
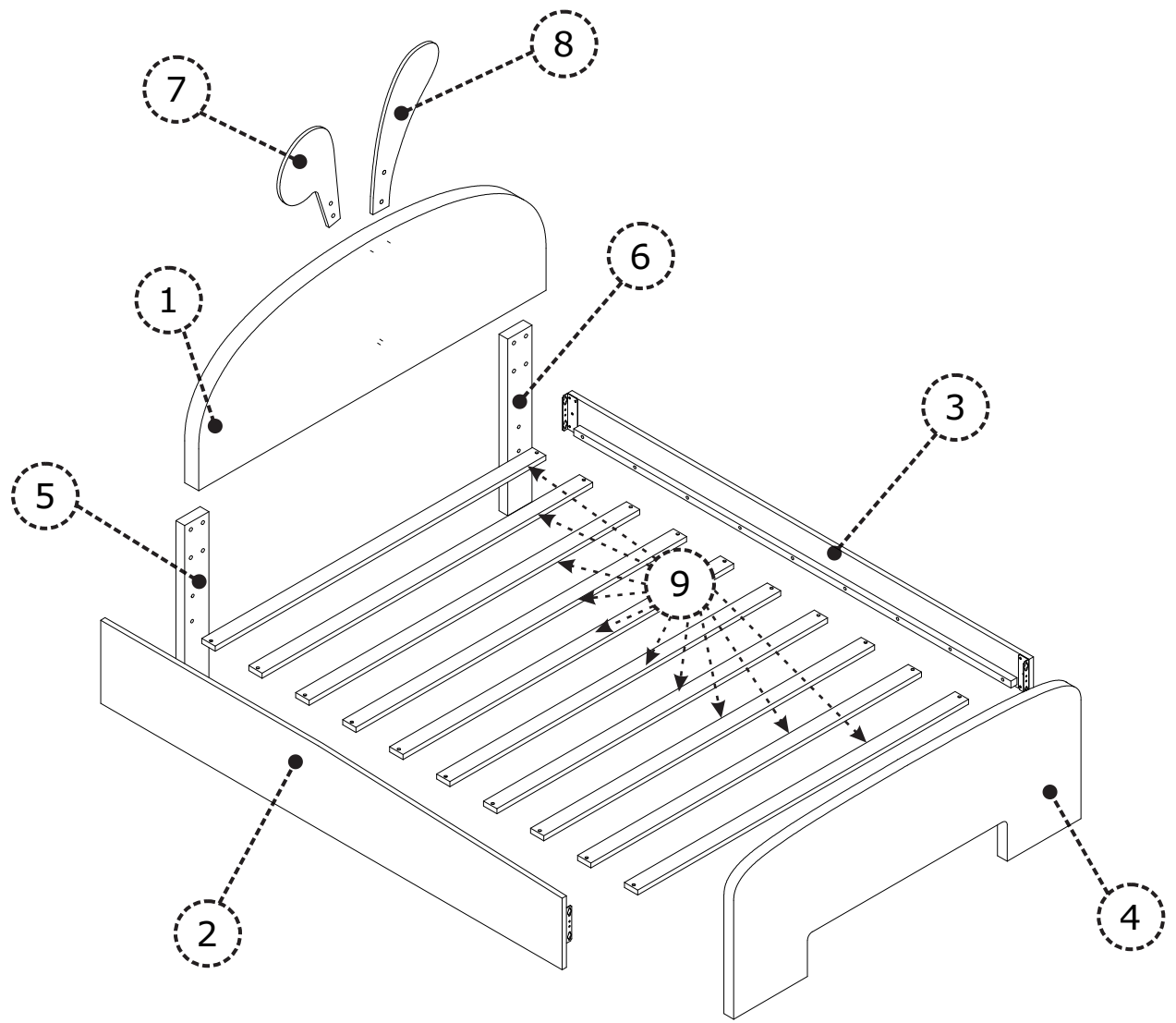

PARTS

Check that you've received
all parts listed below.

BOX: 1/2
WF322150

1 x 1

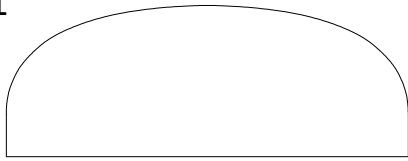

Head Board

4 x 1

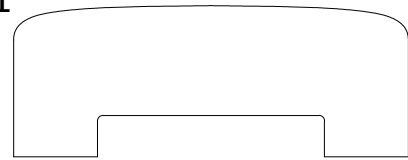

Foot Board

9 x 10



Slats

16 x 3



Bottom Drawer

17 x 3

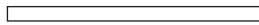

Support Drawer

Hardware

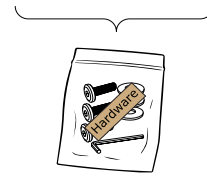

PARTS

Check that you've received
all parts listed below.

BOX: 2/2
WF322151

2 x 1



Side Board Left

3 x 1



Side Board Right

5 x 1



Leg Board Left

6 x 1

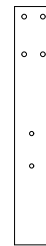

Leg Board Right

7 x 1

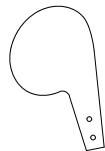

Rabbit Ear Left

8 x 1

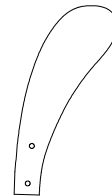

Rabbit Ear Right

12 x 3

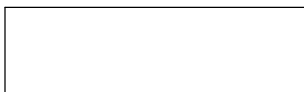

Front Drawers

13 x 3



Back Drawer

14 x 3

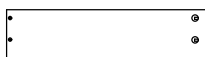

Left Drawer

15 x 3













Right Drawer

HARDWARE

Check that you've received all hardware listed below.

Hardware List

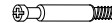
No.	OUTLOOK	DESC	QTY
(A)		Bolts 5/16"x30 mm	12
(B)		Bolts 5/16"x60 mm	8
(C)		Plain washer Ø19x1.5 mm	20
(D)		Spring washer Ø13x1 mm	20
(E)		Allen key 80x30x4 mm	1
(F)		Screws Ø4x30 mm	35
(G)		Screws Ø4x15 mm	54
(H)		Wheel 50x35x38 mm	12
(I)		Steel Pat 50x35x38 mm	3
(K)		Cam lock Ø15x13 mm	12
(L)		Cam lock Ø6x35 mm	12



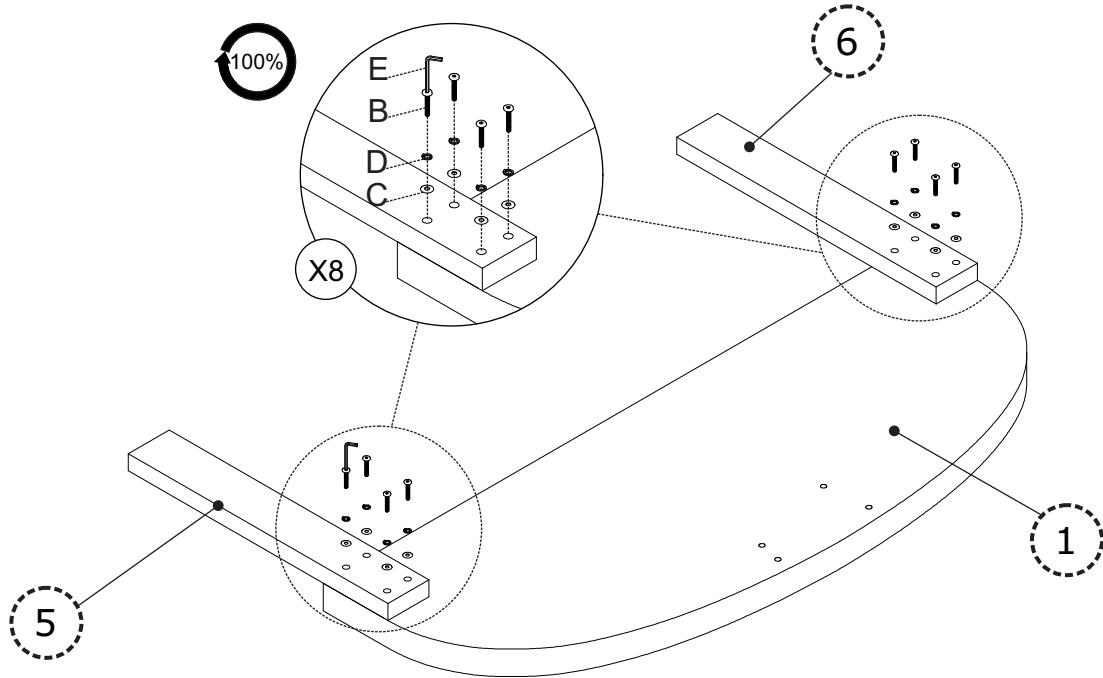
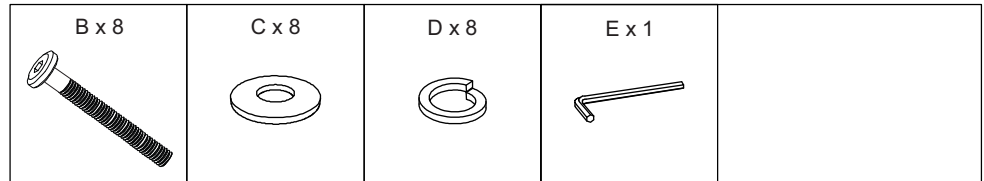

STEP 1

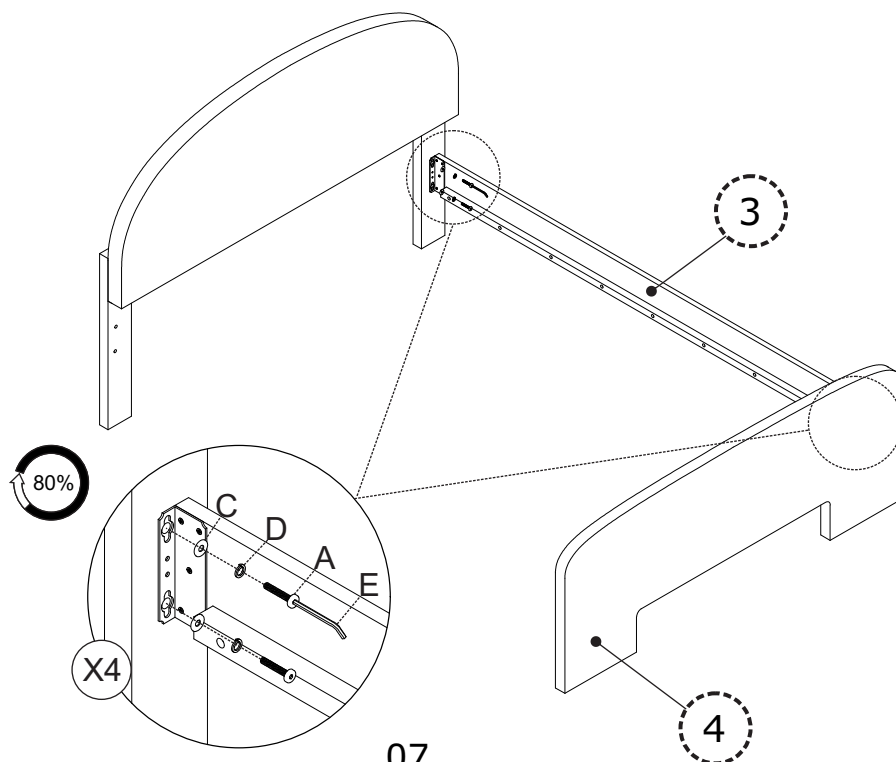
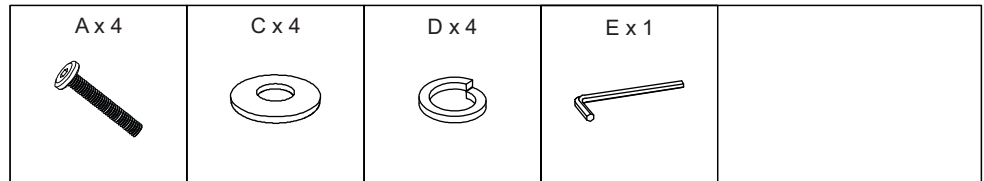

STEP 2



STEP 3

A x 4 	C x 4 	D x 4 	E x 1 	
--	--	--	--	--

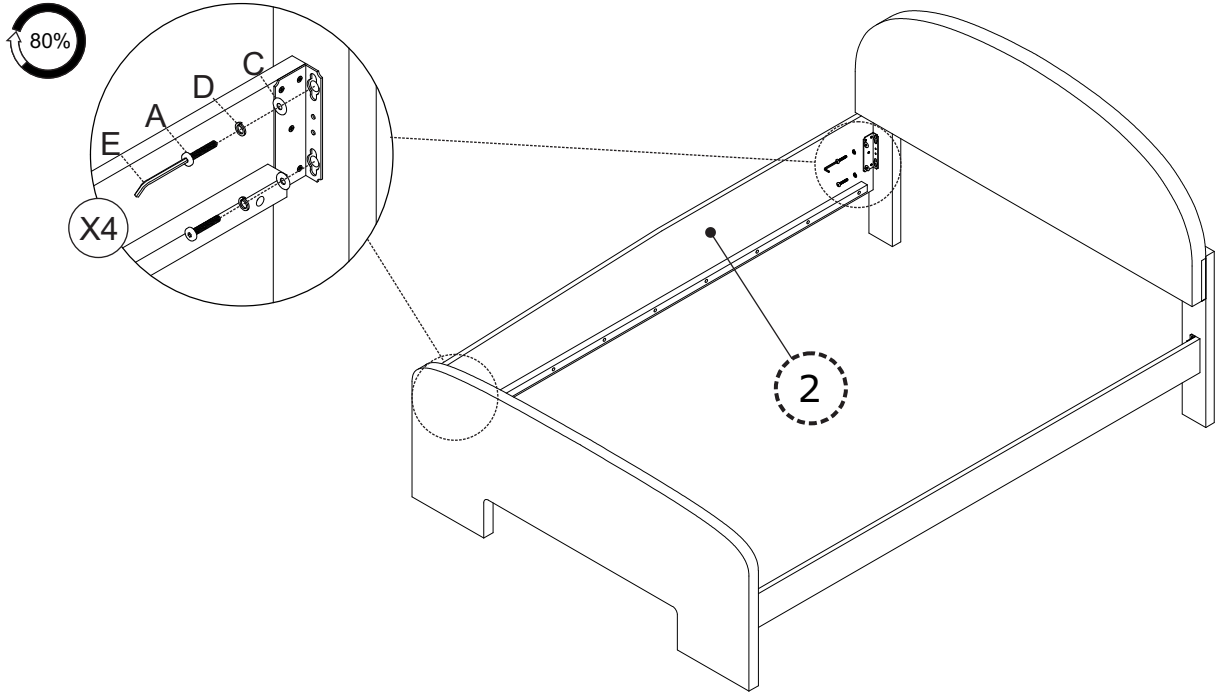

STEP 4

E x 1 				
--	--	--	--	--

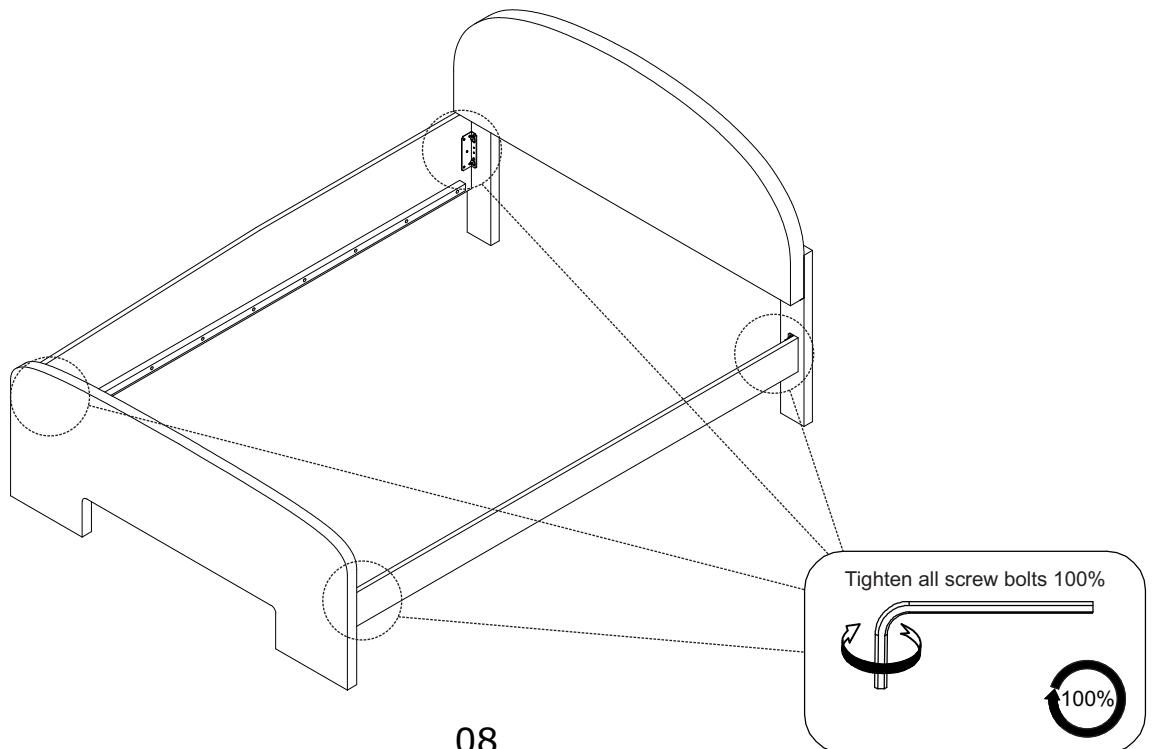

STEP 5

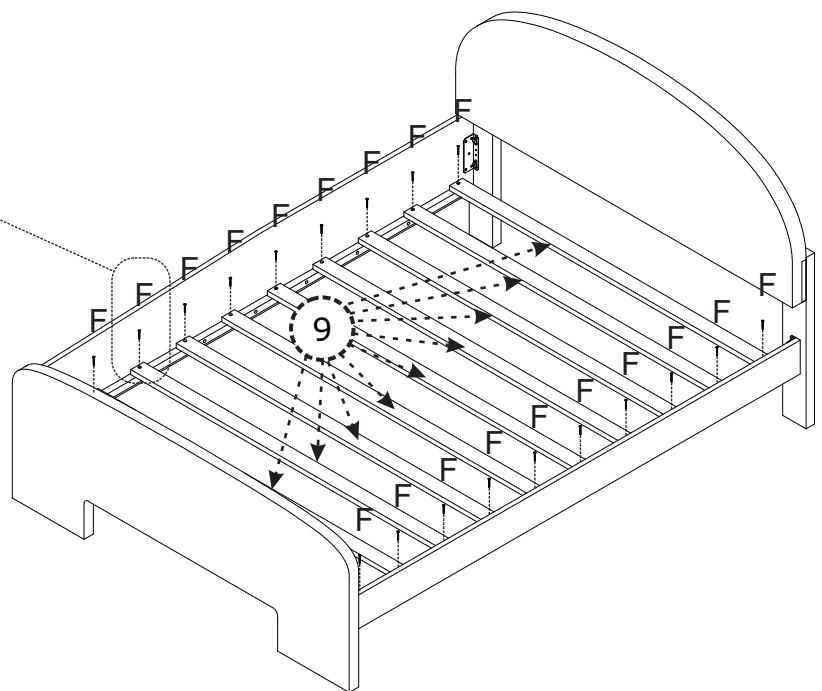
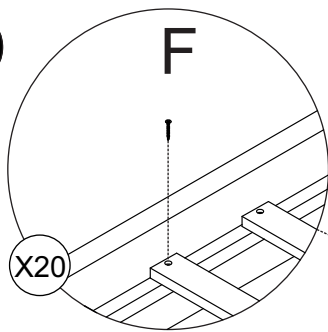

STEP 6

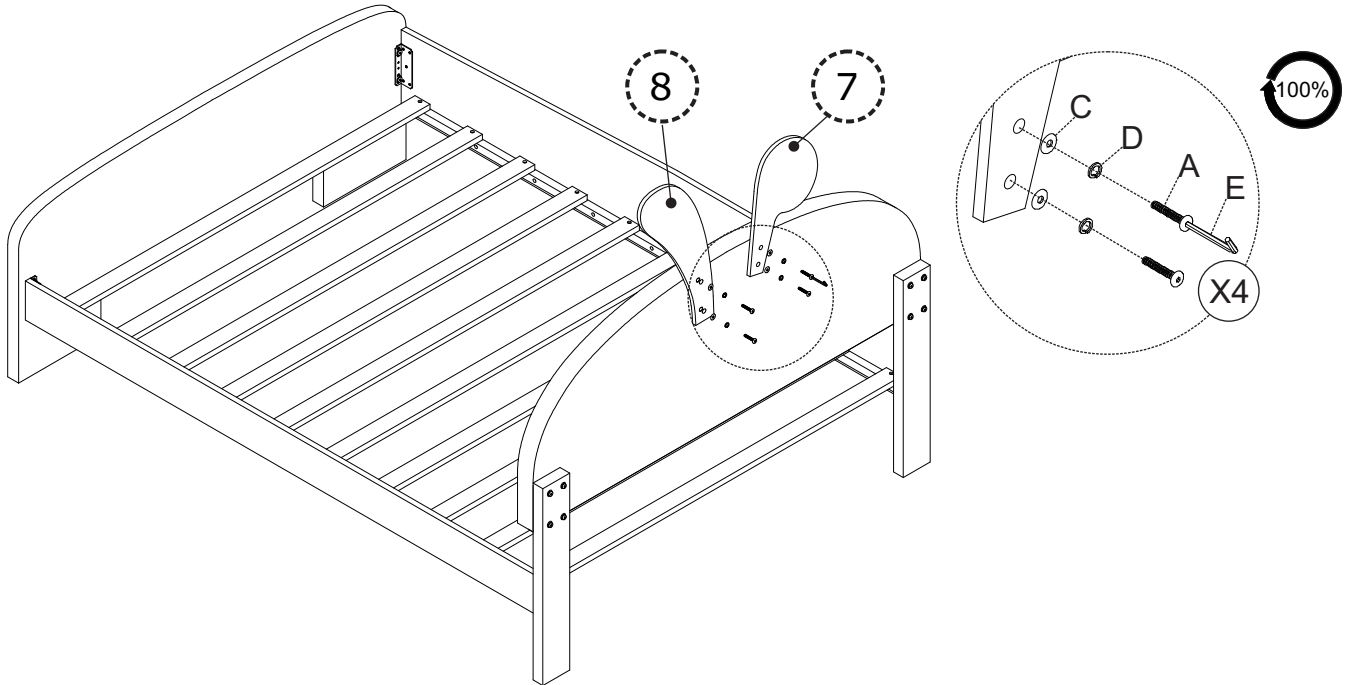
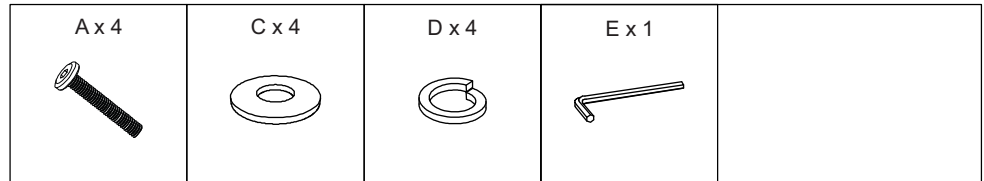

STEP 7

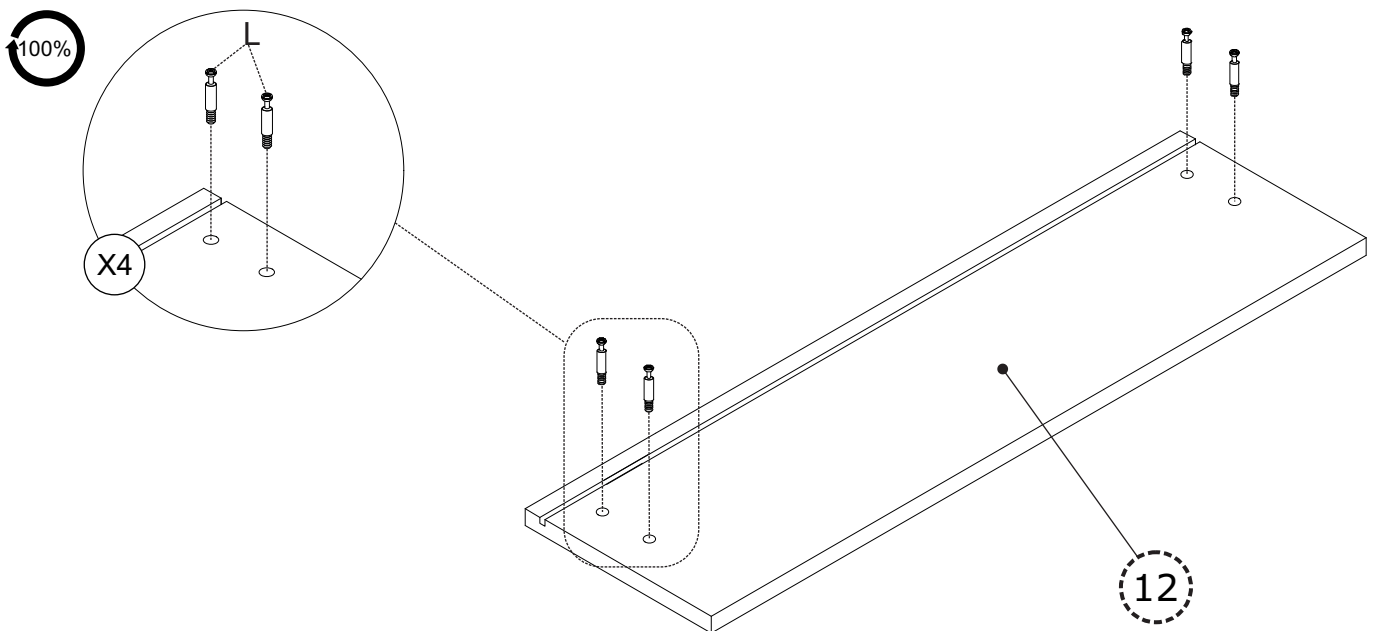
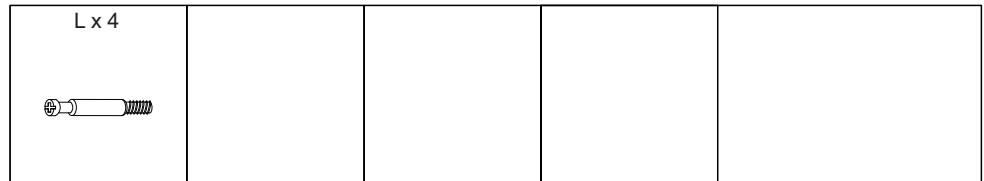

STEP 8

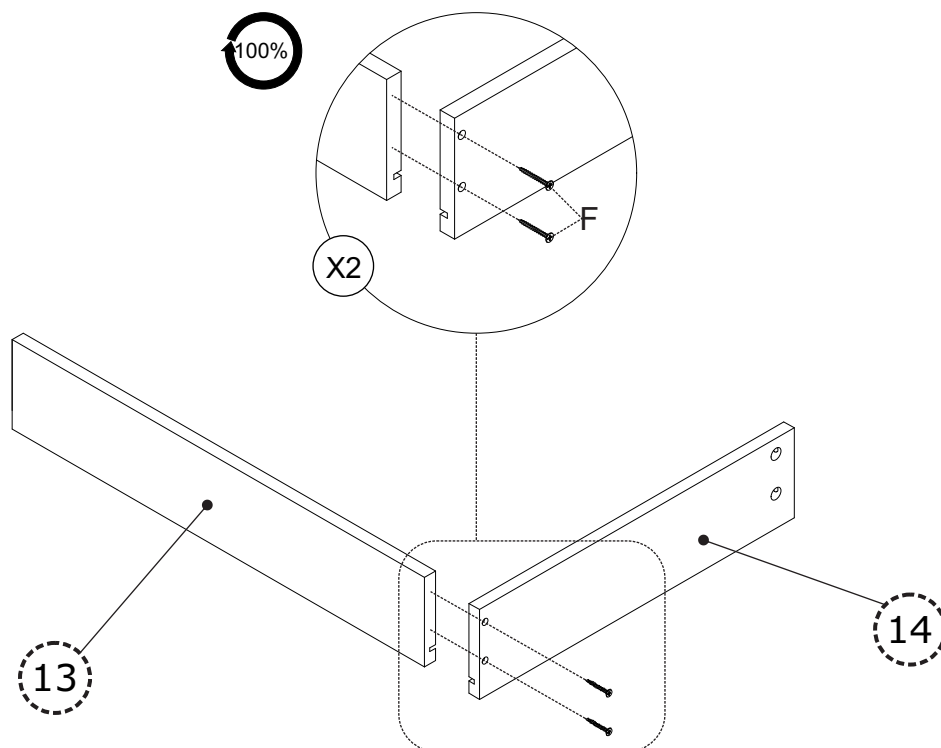
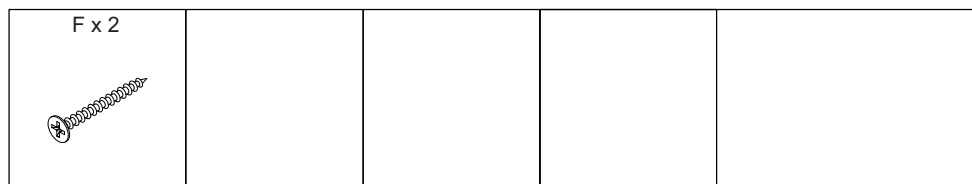

STEP 9

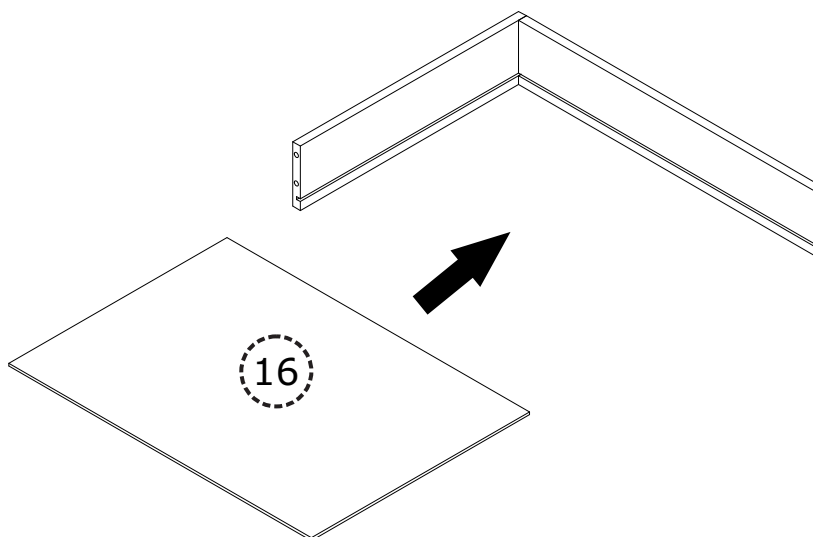
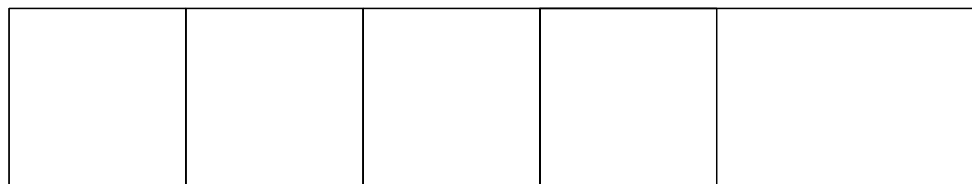

STEP 10

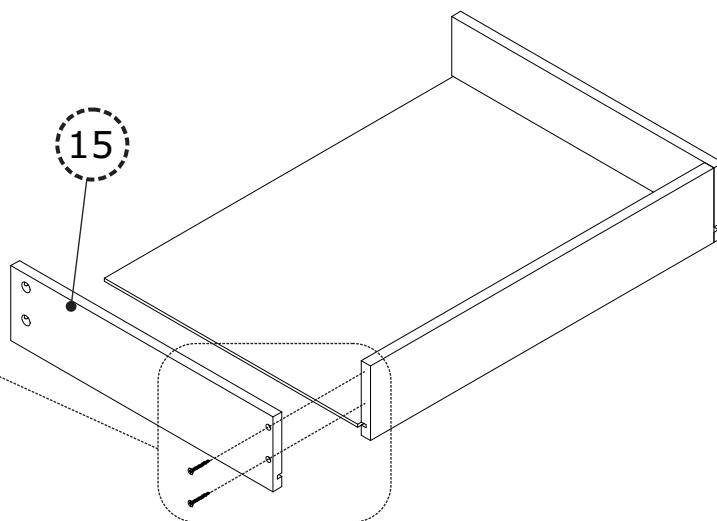
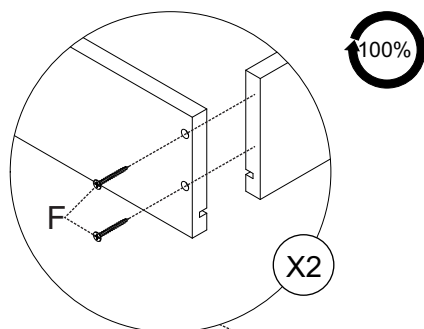
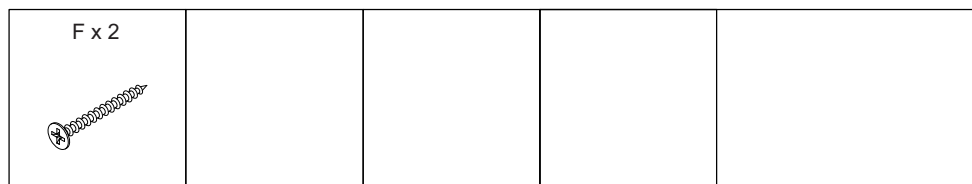

STEP 11

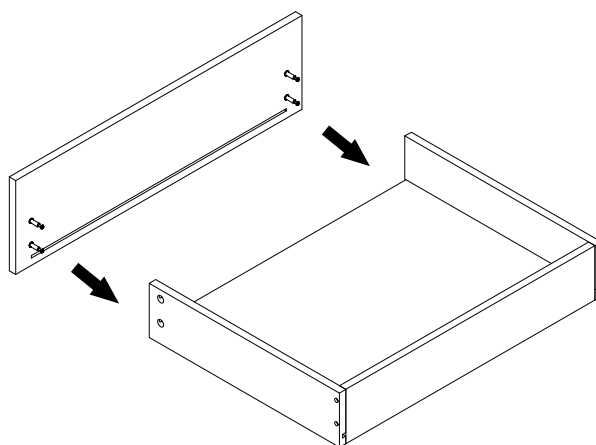
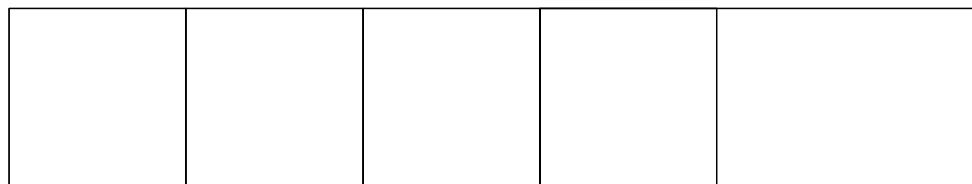

STEP 12

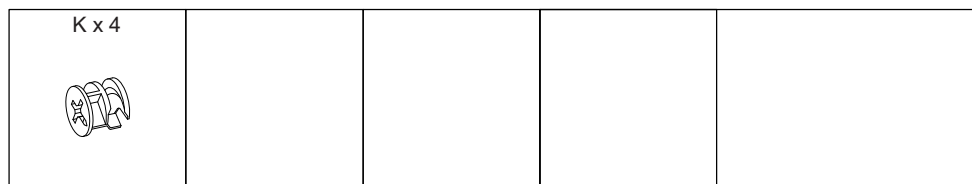

100%

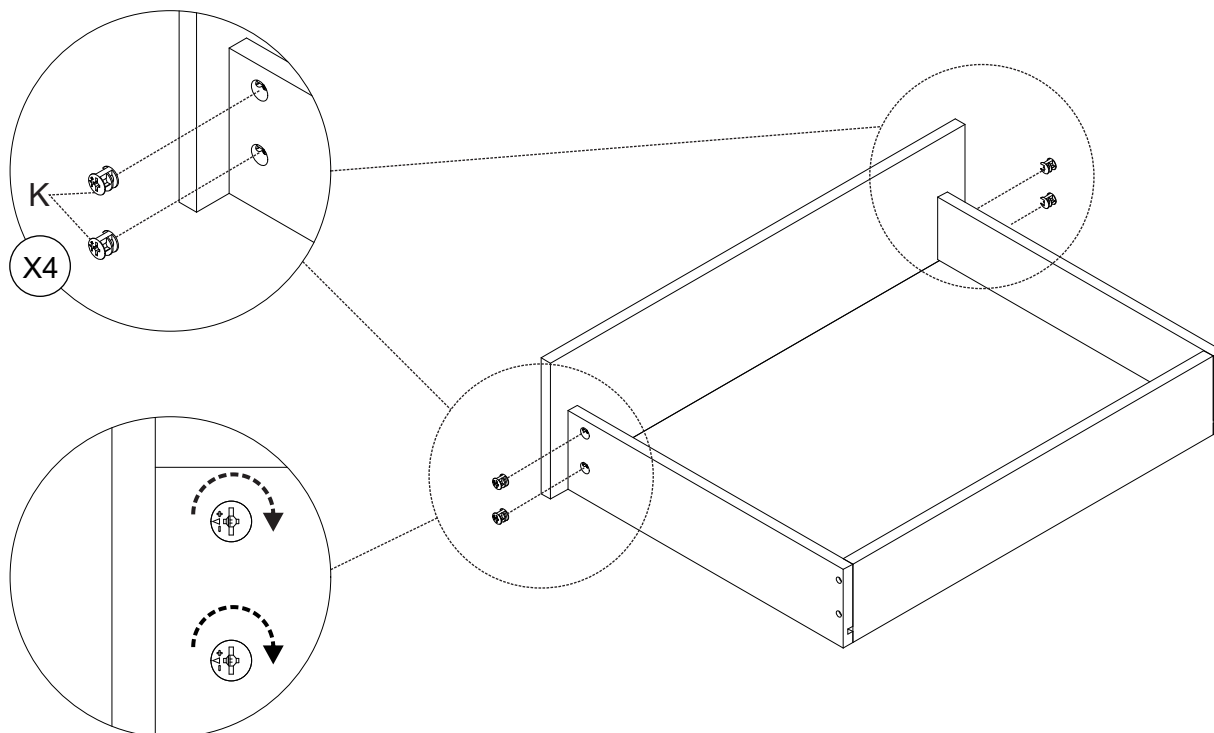

STEP 13

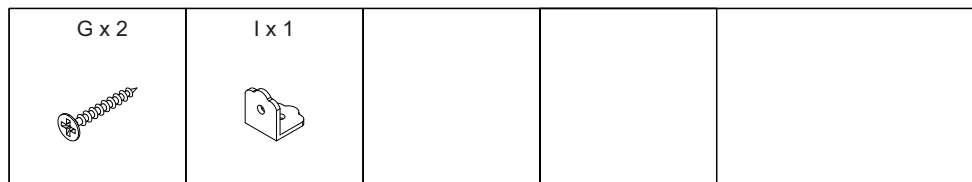

100%

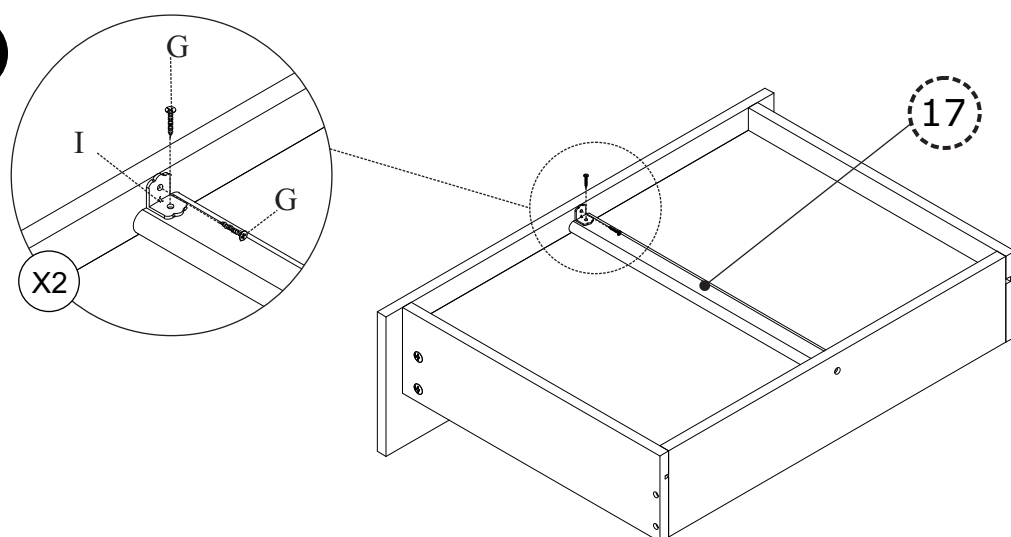

STEP 14

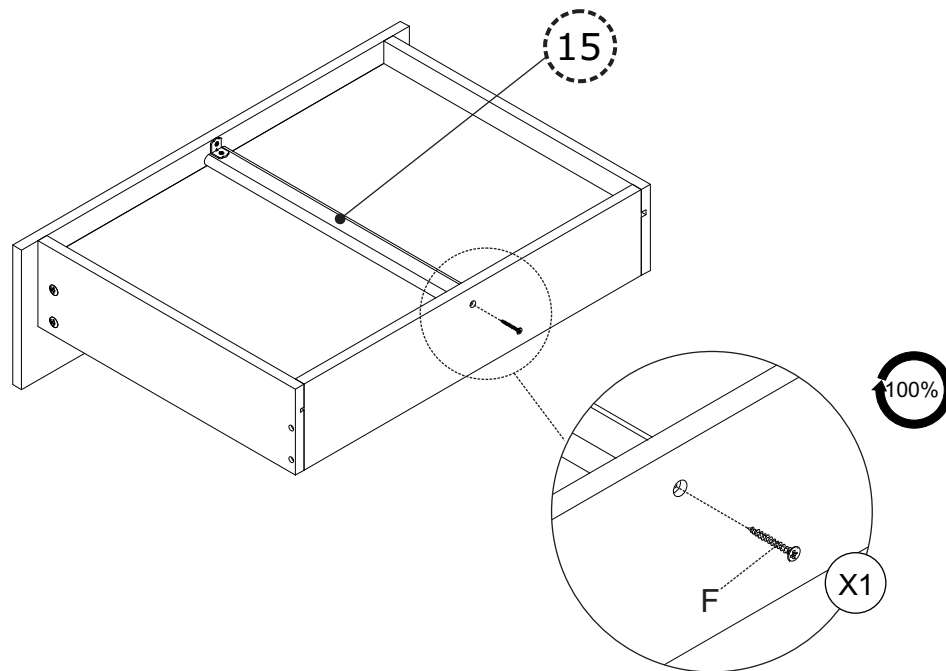
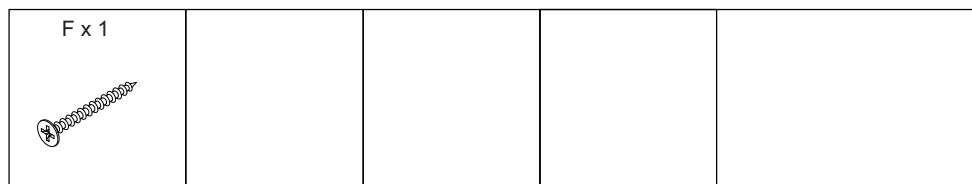

STEP 15

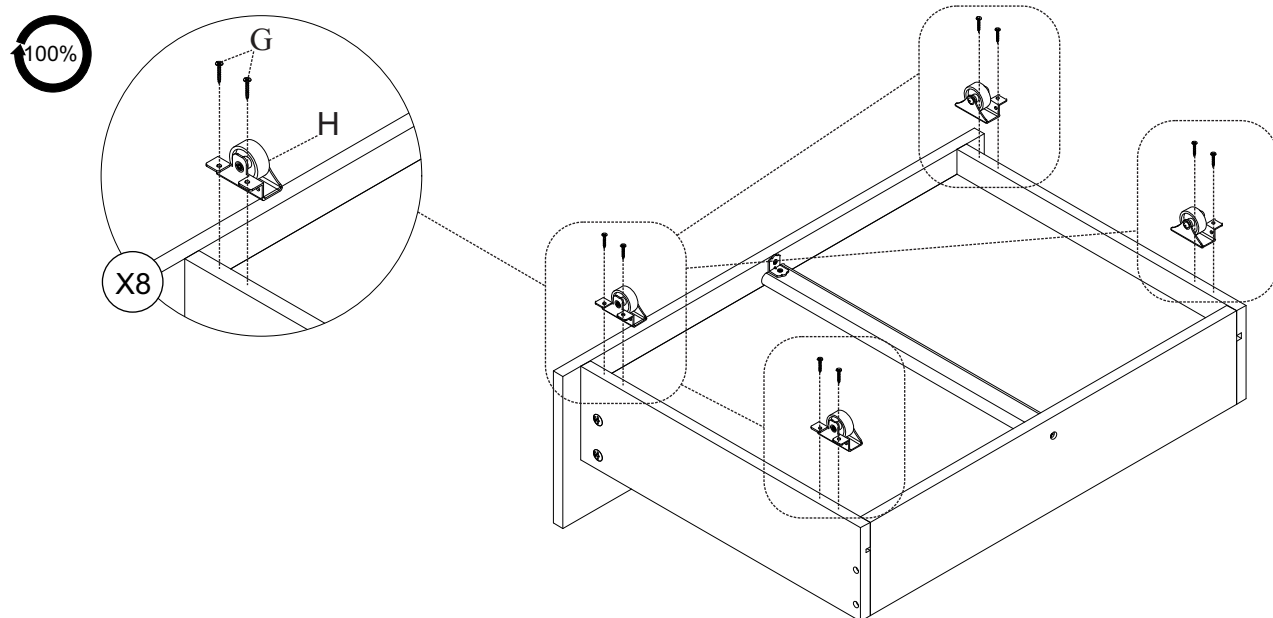
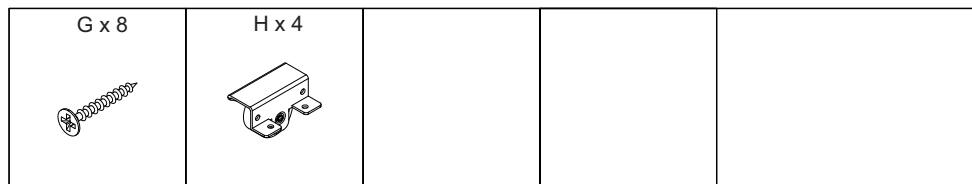

STEP 16

