

Installationsanleitung/Installation Instruction/Instruction d'installation
Istruzioni di installazione/Instrucciones de instalación
Installatie-instructies/Installationsanvisningar/Instrukcje instalacji

BARTISCH BAR TABLE

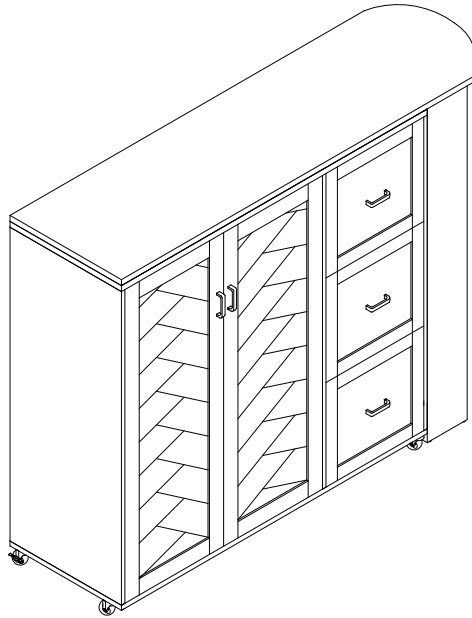

DE: Unser Produkt wird Ihnen in 2 Paketen geliefert. Die Lieferzeiten dieser 2 Pakete können abweichen, bitte haben Sie etwas Geduld und vielen Dank für Ihr Verständnis.

UK: Our product will be delivered to you in 2 packages. The delivery times of these 2 packages may differ, please be patient and thank you for your understanding.

FR: Notre produit vous sera livré en 2 colis. Les délais de livraison de ces 2 colis peuvent différer, soyez patient et merci pour votre compréhension.

IT: Il nostro prodotto verrà consegnato in 2 pacchi. I tempi di consegna di questi 2 pacchi possono variare; vi preghiamo di avere un po' di pazienza e vi ringraziamo per la vostra comprensione.

ES: Nuestro producto se entregará en 2 paquetes. Los tiempos de entrega de estos 2 paquetes pueden variar; por favor, tenga un poco de paciencia y gracias por su comprensión.

Installatie-instructies/Installationsanvisningar/Instrukcje instalacji

NL: Ons product wordt in 2 pakketten bij u geleverd. De levertijden van deze 2 pakketten kunnen verschillen, we vragen om uw geduld en bedanken u voor uw begrip.

SE: Vår produkt kommer att levereras till dig i 2 paket. Leveranstiderna för dessa 2 paket kan variera, vi ber om ditt tålamod och tackar för din förståelse.

PL: Nasz produkt zostanie dostarczony w 2 paczkach. Czas dostawy tych 2 paczek może się różnić, prosimy o cierpliwość i dziękujemy za zrozumienie.

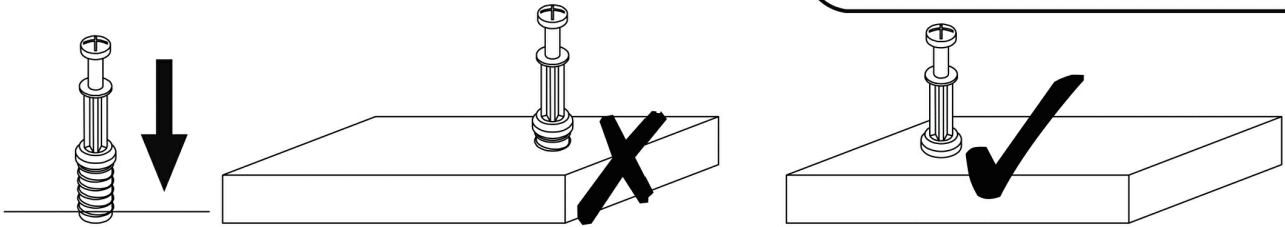

EN_QUICKFIT: Tighten quickfit until shoulder is flush with panel. Do not overtighten or undertighten.

FR_RACCORD RAPIDE: Faites serrer le raccord rapide jusqu'à ce que l'épaulement soit parfaitement encastré dans le panneau. Il ne faut ni trop serrer ni insuffisamment serrer.

ES_QUICKFIT: Apriete quickfit hasta que el hombro se descargue con el panel. NO lo sobreapriete ni lo apriete poco.

DE_QUICKFIT: Ziehen Sie den Quickfit fest, bis die Schulter mit der Platte bündig ist. Bitte nicht zu fest oder zu schwach anziehen.

IT_MONTAGGIO RAPIDO: Stringere il montaggio rapido fino a quando la spalla è a filo con il pannello, non stringere troppo o troppo poco.

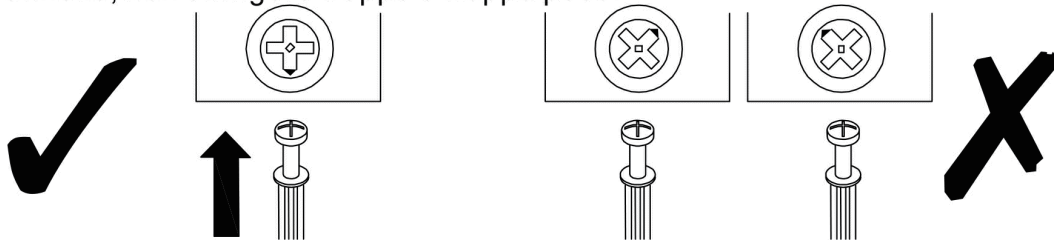

EN_CAM LOCK: When fitting cam lock, ensure starting position is correct before you insert connecting quickfit.

FR_SERRURE BATTEUSE: Avant d'insérer la serrure batteuse, veillez à la bonne orientation avant d'insérer le raccord rapide.

ES_CIERRE DE LA CÁMARA: Cuando instale el cierre de la cámara, asegúrese de que la posición de inicio es correcta antes de que inserte el quickfit conector.

DE_CAM-LOCK: Achten Sie bei der Montage des Cam-Locks auf die richtige Ausgangsposition, bevor Sie den Quickfit einsetzen.

IT_BLOCCAGGIO A CAMMA: Quando si monta il bloccaggio a camma, assicurarsi che la posizione iniziale sia corretta prima di inserire il montaggio rapido di collegamento.

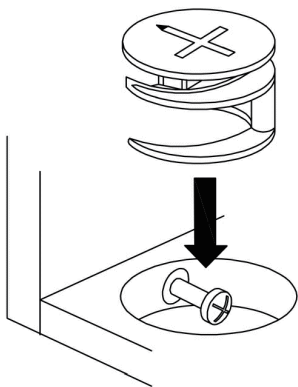

EN_Quickfit head should be in the centre of the cam lock when the two panels are joined.

Cam lock should be inserted before quickfit.

FR_Lorsque les deux panneaux sont assemblés, la tête du raccord rapide doit reposer au centre de la serrure batteuse.

Il faut insérer la serrure batteuse avant le raccord rapide.

ES_El cabezal del quickfit debe estar en el centro del cierre de la cámara cuando se unan los dos paneles.

Se debe insertar el cierre de la cámara antes que el quickfit.

DE_Der Quickfit-Kopf sollte sich in der Mitte des Cam-Locks befinden, wenn die beiden Platten zusammengefügt sind.

Der Cam-Lock sollte vor dem Quickfit eingesetzt werden.

IT_La testa del montaggio rapido deve trovarsi al centro del bloccaggio a camma quando i due pannelli sono uniti.

Il Bloccaggio a Camma deve essere inserito prima del montaggio rapido.

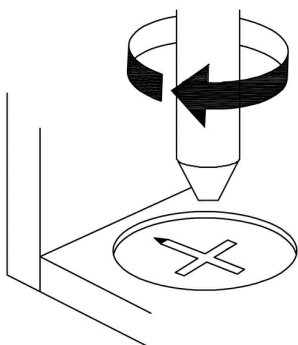

EN_Turn cam lock clockwise to tighten.

FR_Faites tourner la serrure batteuse dans le sens des aiguilles d'une montre pour la resserrer.

ES_Gire el cierre de la cámara en sentido horario para apretarlo.

DE_Drehen Sie den Cam-Lock im Uhrzeigersinn, um ihn festzuziehen.

IT_Ruotare il bloccaggio a camma in senso orario per stringere.

DE

1. Die maximale Tragfähigkeit der Oberplatte beträgt 60 kg, bitte nicht überladen.
2. Lassen Sie Kinder nicht auf Möbeln klettern, da dies zu Umstürzen und schweren Verletzungen führen kann.
3. Um die Sicherheit zu gewährleisten, installieren Sie bitte gemäß der Anleitung und ziehen Sie bei Bedarf Fachleute hinzu.
4. Stellen Sie Möbel nicht in die Nähe von Feuerquellen oder heißen Gegenständen, um Brandgefahr zu vermeiden.
5. Stellen Sie Möbel nicht in feuchten Umgebungen auf, um Materialschäden zu verhindern.
6. Überprüfen Sie regelmäßig alle Verbindungs- und Befestigungselemente, um sicherzustellen, dass sie fest sitzen und Unfälle zu vermeiden.
7. Dieses Produkt ist mit einem Kipp-Schutz ausgestattet, installieren Sie diesen Schutz, um Verletzungen durch Umstürzen zu vermeiden.

UK

1. The maximum weight capacity of the top panel is 60kg; please do not overload.
2. Do not allow children to climb on furniture, as this may cause tipping and serious injury.
3. To ensure safety, please install correctly according to the instructions and seek professional assistance if necessary.
4. Do not place furniture near fire sources or hot objects to avoid fire hazards.
5. Do not place furniture in damp environments to prevent material damage.
6. Regularly check all connectors and fasteners to ensure they are secure to prevent accidents.
7. This product comes with a anti-tipping device; install this device to prevent injuries from tipping.

FR

1. La charge maximale du panneau supérieur est de 60 kg, ne pas surcharger.
2. Ne laissez pas les enfants grimper sur les meubles, cela peut entraîner des basculements et des blessures graves.
3. Pour garantir la sécurité, installez correctement selon les instructions et demandez l'aide de professionnels si nécessaire.
4. Ne placez pas les meubles près de sources de chaleur ou d'objets chauds pour éviter les risques d'incendie.
5. Ne placez pas les meubles dans des environnements humides pour éviter d'endommager les matériaux.
6. Vérifiez régulièrement tous les connecteurs et les fixations pour vous assurer qu'ils sont bien serrés et éviter les accidents.
7. Ce produit est équipé d'un dispositif anti-basculement; installez ce dispositif pour éviter les blessures dues au basculement.

IT

1. La capacità massima del pannello superiore è di 60 kg; non sovraccaricare.
2. Non permettere ai bambini di arrampicarsi sui mobili, poiché ciò può causare ribaltamenti e gravi infortuni.
3. Per garantire la sicurezza, installare correttamente secondo le istruzioni e, se necessario, chiedere assistenza a professionisti.
4. Non posizionare i mobili vicino a fonti di calore o oggetti caldi per evitare rischi di incendio.
5. Non posizionare i mobili in ambienti umidi per prevenire danni ai materiali.
6. Controllare regolarmente tutti i connettori e le viti per assicurarsi che siano saldi e prevenire incidenti.
7. Questo prodotto è dotato di un dispositivo anti-ribaltamento; installare questo dispositivo per evitare infortuni da ribaltamento.

ES

1. La capacidad máxima del panel superior es de 60 kg; no sobrecargar.
2. No permita que los niños escalen los muebles, ya que esto puede causar volcaduras y lesiones graves.
3. Para garantizar la seguridad, instale correctamente según las instrucciones y busque ayuda profesional si es necesario.
4. No coloque los muebles cerca de fuentes de fuego u objetos calientes para evitar riesgos de incendio.
5. No coloque los muebles en ambientes húmedos para evitar daños en los materiales.
6. Revise regularmente todos los conectores y sujetadores para asegurarse de que estén seguros y prevenir accidentes.
7. Este producto viene con un dispositivo anti-vuelco; instale este dispositivo para prevenir lesiones por vuelcos.

NL

1. De maximale draagcapaciteit van het bovenpaneel is 60 kg; niet overbelasten.
2. Laat kinderen niet op meubels klimmen, dit kan leiden tot omvallen en ernstige verwondingen.
3. Installeer correct volgens de instructies om de veiligheid te waarborgen, en schakel indien nodig professionele hulp in.
4. Plaats meubels niet in de buurt van vuurbronnen of warme objecten om brandgevaar te voorkomen.
5. Plaats meubels niet in vochtige omgevingen om materiaalschade te voorkomen.
6. Controleer regelmatig alle verbindingen en bevestigingsmiddelen om ervoor te zorgen dat ze stevig zijn en om ongevallen te voorkomen.
7. Dit product is uitgerust met een kantelbeveiliging; installeer dit apparaat om verwondingen door omvallen te voorkomen.

SE

1. Den maximala viktkapaciteten för överpanelen är 60 kg; överbelasta inte.
2. Låt inte barn klättra på möbler, då detta kan orsaka tippning och allvarliga skador.
3. För att säkerställa säkerheten, installera korrekt enligt instruktionerna och sök professionell hjälp om det behövs.
4. Placera inte möbler nära eldkällor eller heta föremål för att undvika brandrisk.
5. Placera inte möbler i fuktiga miljöer för att förhindra skador på materialen.
6. Kontrollera regelbundet alla kopplingar och fästelement för att säkerställa att de är säkra för att förhindra olyckor.
7. Denna produkt levereras med en anti-tippanordning; installera denna anordning för att förhindra skador vid tippning.

PL

1. Maksymalne obciążenie górnej płyty wynosi 60 kg; nie przeciążaj.
2. Nie pozwól dzieciom wspinąć się na meble, ponieważ może to prowadzić do przewrócenia się i poważnych obrażeń.
3. Aby zapewnić bezpieczeństwo, zainstaluj prawidłowo zgodnie z instrukcją i w razie potrzeby skorzystaj z pomocy profesjonalistów.
4. Nie stawiaj mebli w pobliżu źródeł ognia lub gorących przedmiotów, aby uniknąć ryzyka pożaru.
5. Nie stawiaj mebli w wilgotnych środowiskach, aby zapobiec uszkodzeniu materiałów.
6. Regularnie sprawdzaj wszystkie złącza i elementy mocujące, aby upewnić się, że są stabilne i aby zapobiec wypadkom.
7. Produkt ten jest wyposażony w urządzenie zapobiegające przewróceniu; zainstaluj to urządzenie, aby uniknąć obrażeń w wyniku przewrócenia.

-Components - fittings

Please check you have all the panels listed below.

Note: The quantitie below are the correct amount to complete the assembly. In some cases more fittings may be supplied than are required.

-Komponenten Verschraubungen

Bitte überprüfen Sie, ob Sie alle unten aufgeführten Panels haben.

Hinweis: Die folgende Menge ist die richtige Menge, um die Montage abzuschließen. In einigen Fällen

können mehr Armaturen geliefert werden, als erforderlich.

-Composants - accessoires





Veuillez vérifier que vous possédez tous les panneaux énumérés ci - dessous.

Remarque: les quantités ci - dessous sont les quantités correspondantes nécessaires pour terminer

l'assemblage. Dans certains cas, plus d'accessoires que nécessaire peuvent être fournis.

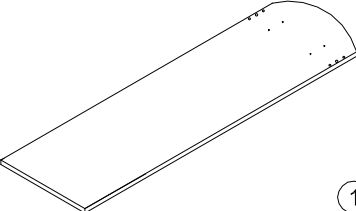
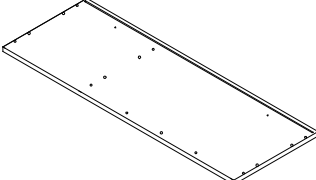
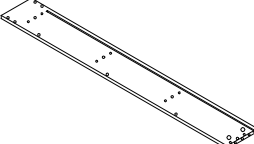
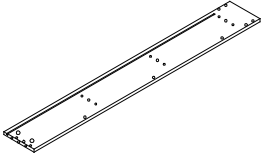
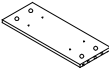
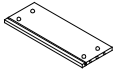
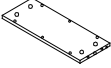

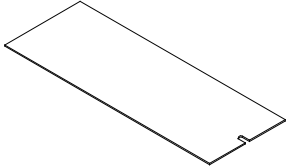
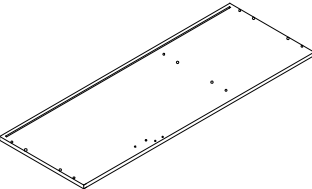

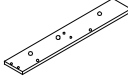
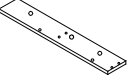

Box:1/2

Box:1/2

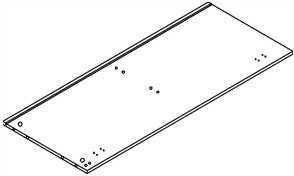
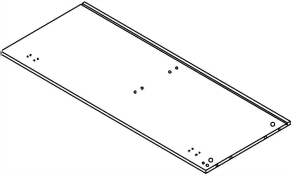
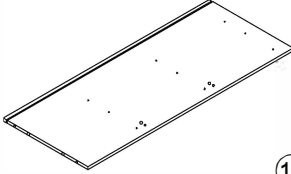
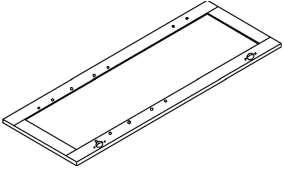
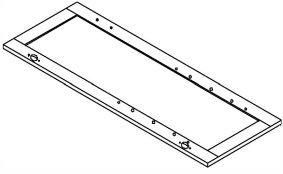
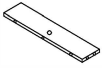
 <p>① X1</p>	 <p>② X1</p>	 <p>③ X1</p>
 <p>④ X1</p>	 <p>⑤ X1</p>	 <p>⑥ X2</p>
 <p>⑦ X1</p>	 <p>⑧ X3</p>	 <p>⑨ X1</p>
 <p>⑩ X1</p>	 <p>⑪ X4</p>	 <p>⑫ X2</p>
 <p>⑬ X2</p>		

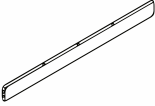
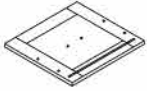
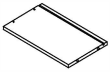
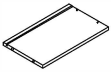
Box:2/2

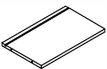
Box:2/2

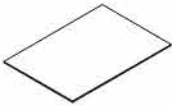
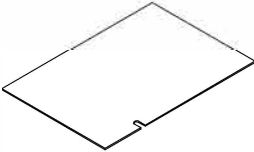
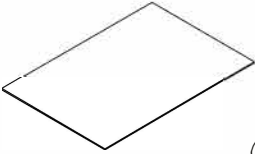
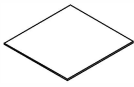
 <p>⑭X1</p>	 <p>⑮X1</p>	 <p>⑯X1</p>
 <p>⑰X1</p>	 <p>⑱X1</p>	 <p>⑲X2</p>
 <p>⑳X2</p>	 <p>㉑X1</p>	 <p>㉒X3</p>
 <p>㉓X3</p>	 <p>㉔X3</p>	 <p>㉕X1</p>
 <p>㉖X3</p>	 <p>㉗X4</p>	 <p>㉘X3</p>
 <p>㉙X1</p>	 <p>㉚X1</p>	 <p>㉛X3</p>

-Components - fittings

Please check you have all the panels listed below.

Note: The quantitie below are the correct amount to complete the assembly. In some cases more fittings may be supplied than are required.

-Komponenten Verschraubungen

Bitte überprüfen Sie, ob Sie alle unten aufgeführten Panels haben.

Hinweis: Die folgende Menge ist die richtige Menge, um die Montage abzuschließen. In einigen Fällen

können mehr Armaturen geliefert werden, als erforderlich.

-Composants - accessoires











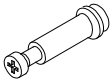

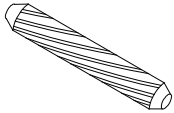
Veillez vérifier que vous possédez tous les panneaux énumérés ci - dessous.

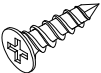
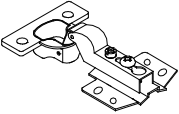
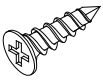
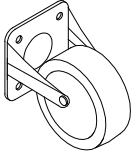
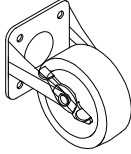
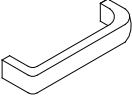
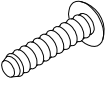
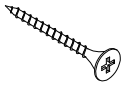
Remarque: les quantités ci - dessous sont les quantités correspondantes nécessaires pour terminer

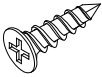
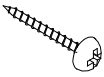
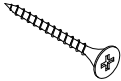
l'assemblage. Dans certains cas, plus d'accessoires que nécessaire peuvent être fournis.

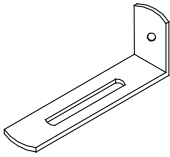
Box:1

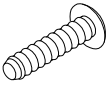
Box:1

				
6*35mm	15*10mm	6*30mm	300mm	3*12mm
Ax80PCS	Bx80PCS	Cx53PCS	Dx3PCS	Ex32PCS
				
Fx4PCS	4*12mm	Hx3PCS	Ix2PCS	Jx5PCS
				
4*14mm	4*40mm	Mx24PCS	3*14mm	4*25mm
Kx4PCS	Lx8PCS	Nx24PCS	Nx24PCS	Ox4PCS
				
4*30mm	4*14mm	Rx2PCS	Sx2PCS	4*8mm
Px12PCS	Qx20PCS			Tx6PCS
				
Ux1PC				

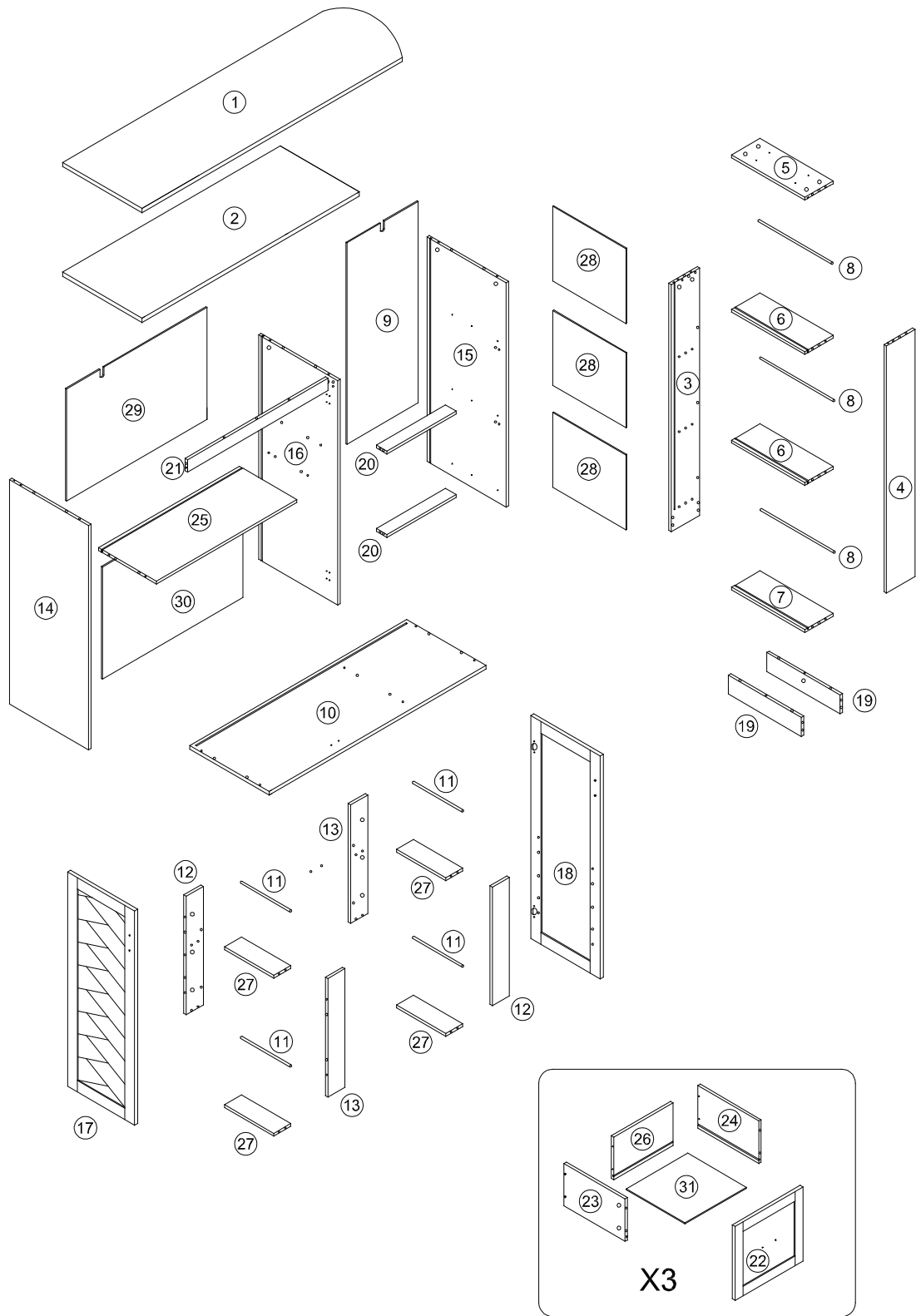

STEP 1/SCHRITT 1/Étapes 1/Passo 1/Paso 1

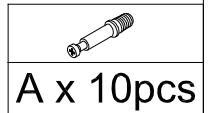
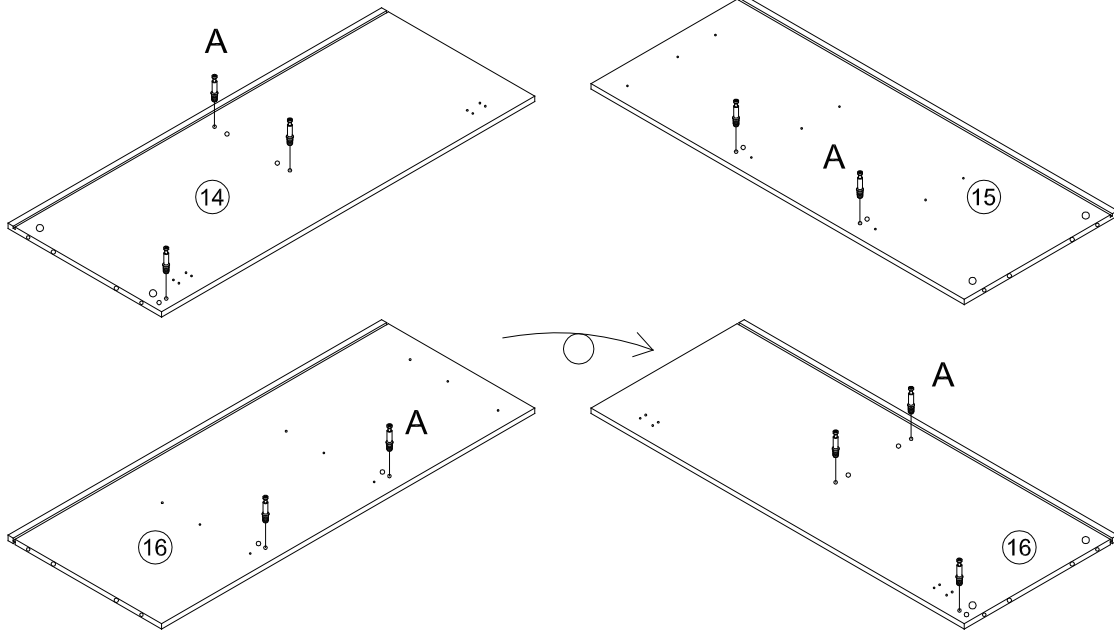

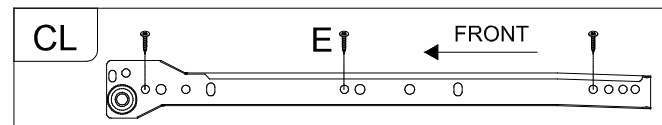
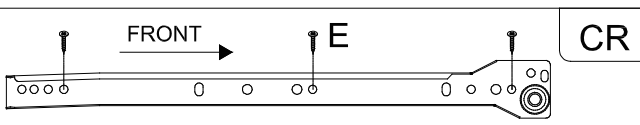
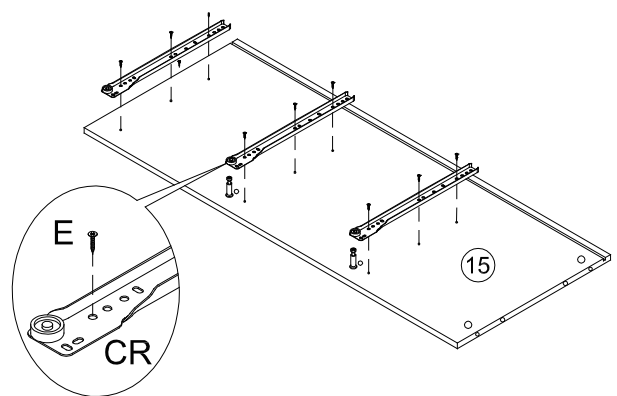
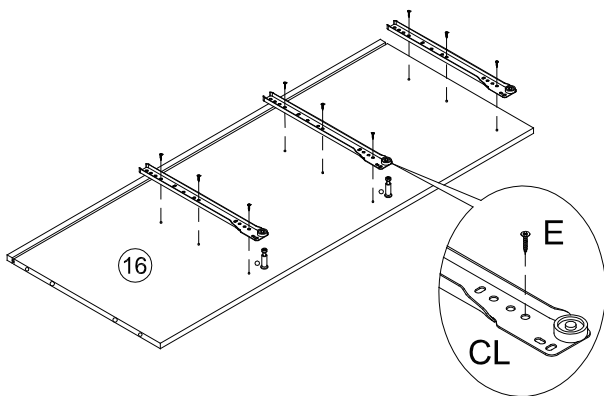
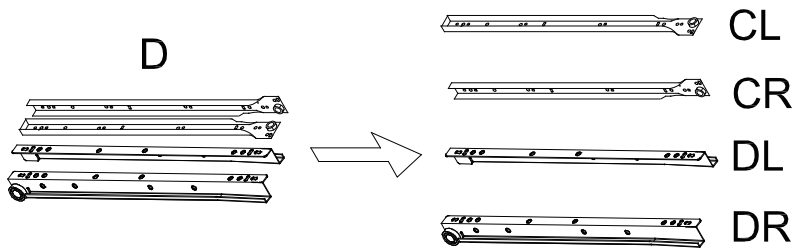

STEP 2/SCHRITT 2/Étapes 2/Passo 2/Paso 2



E x 18pcs	CL x 3pcs	CR x 3pcs

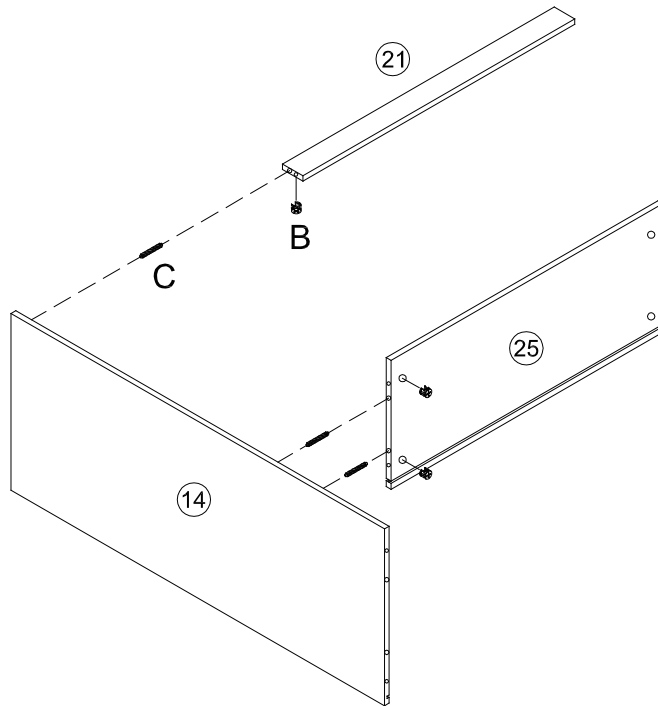

STEP 3/SCHRITT 3/Étapes 3/Passo 3/Paso 3



	
B x 3pcs	C x 3pcs

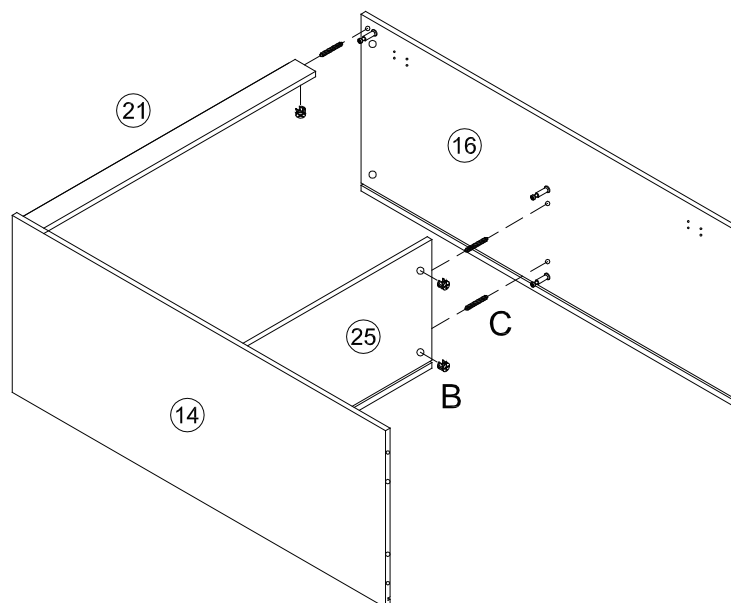

STEP 4/SCHRITT 4/Étapes 4/Passo 4/Paso 4



	
B x 3pcs	C x 3pcs

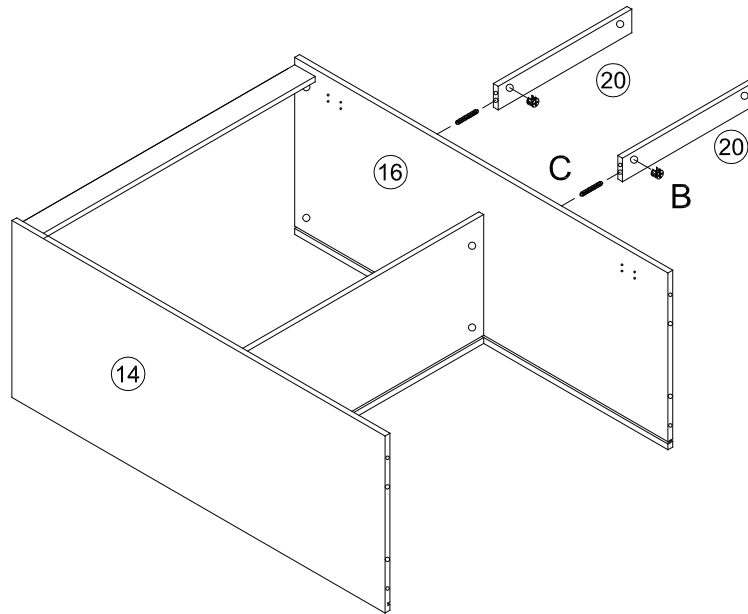

STEP 5/SCHRITT 5/Étapes 5/Passo 5/Paso 5

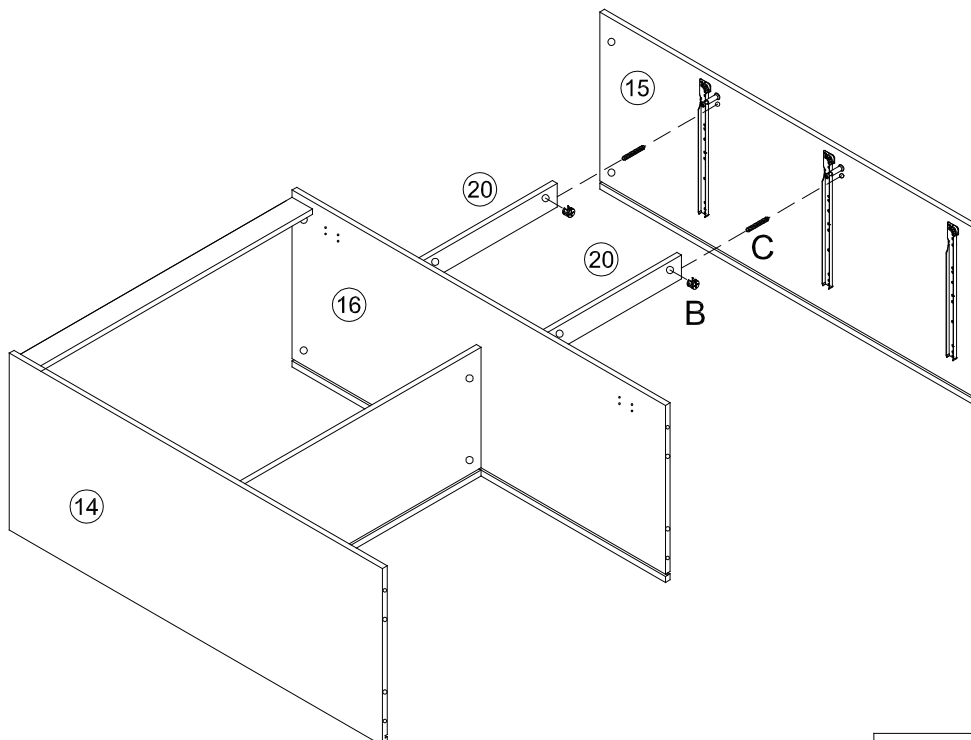

	
B x 2pcs	C x 2pcs

STEP 6/SCHRITT 6/Étapes 6/Passo 6/Paso 6



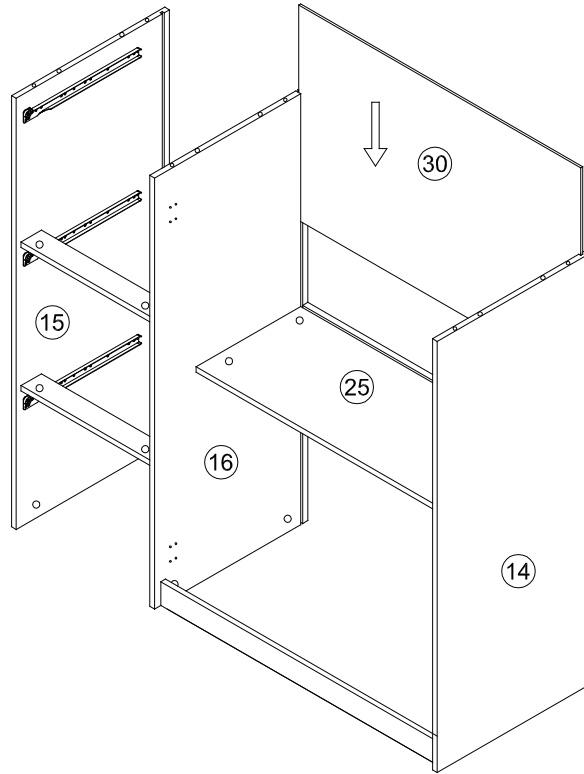

	
B x 2pcs	C x 2pcs

STEP 7/SCHRITT 7/Étapes 7/Passo 7/Paso 7



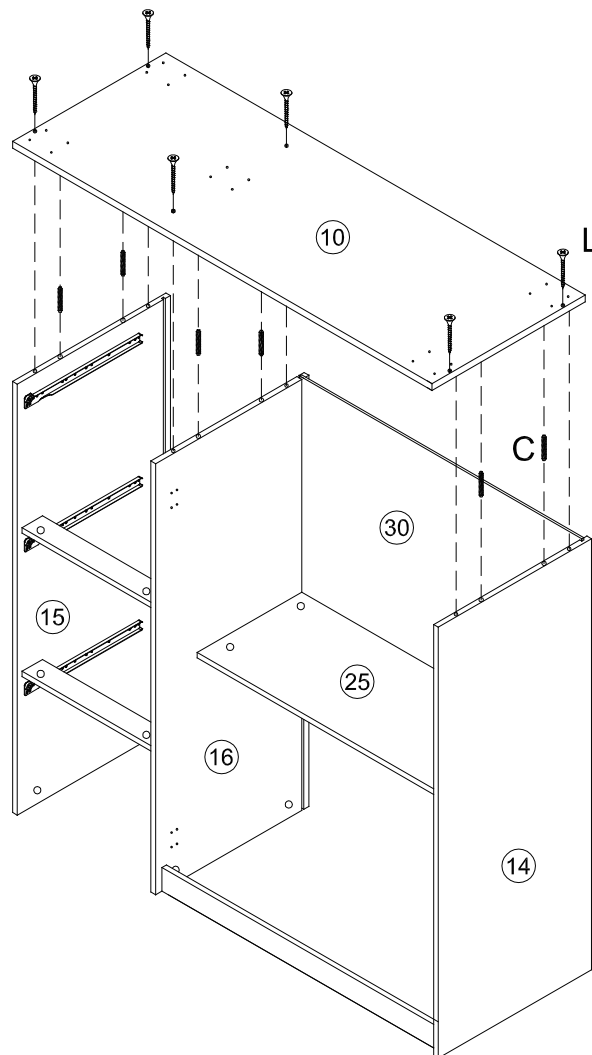



STEP 8/SCHRITT 8/Étapes 8/Passo 8/Paso 8

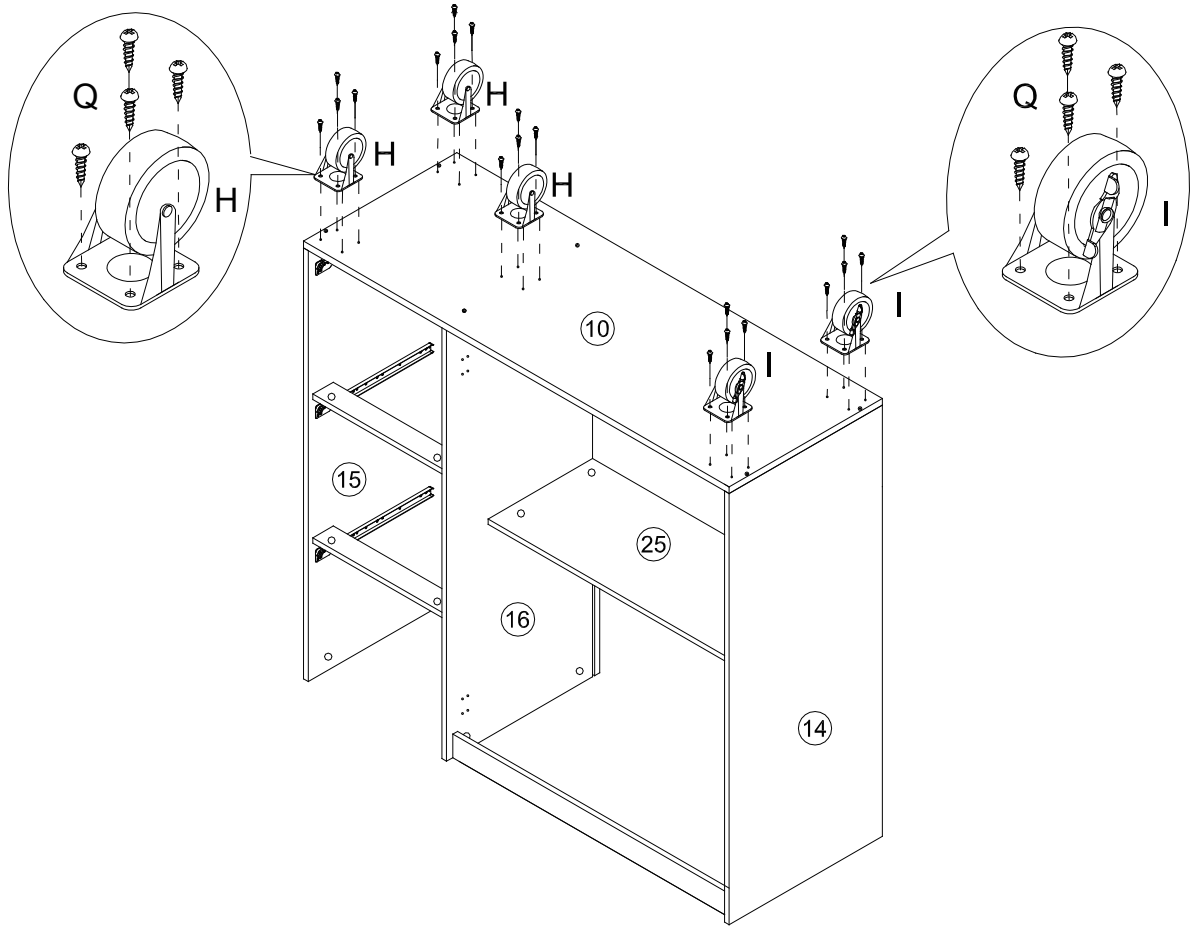

	
C x 6pcs	L x 6pcs



STEP 9/SCHRITT 9/Étapes 9/Passo 9/Paso 9



		
H x 3pcs	I x 2pcs	Q x 20pcs

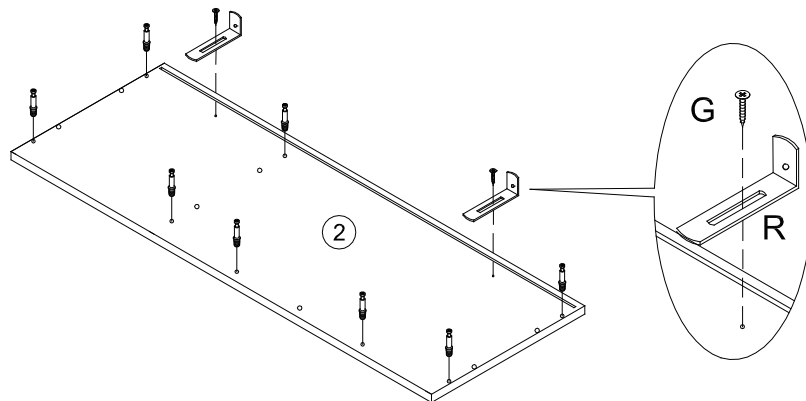

STEP 10/SCHRITT 10/Étapes 10/Passo 10/Paso 10



		
A x 8pcs	G x 2pcs	R x 2pcs

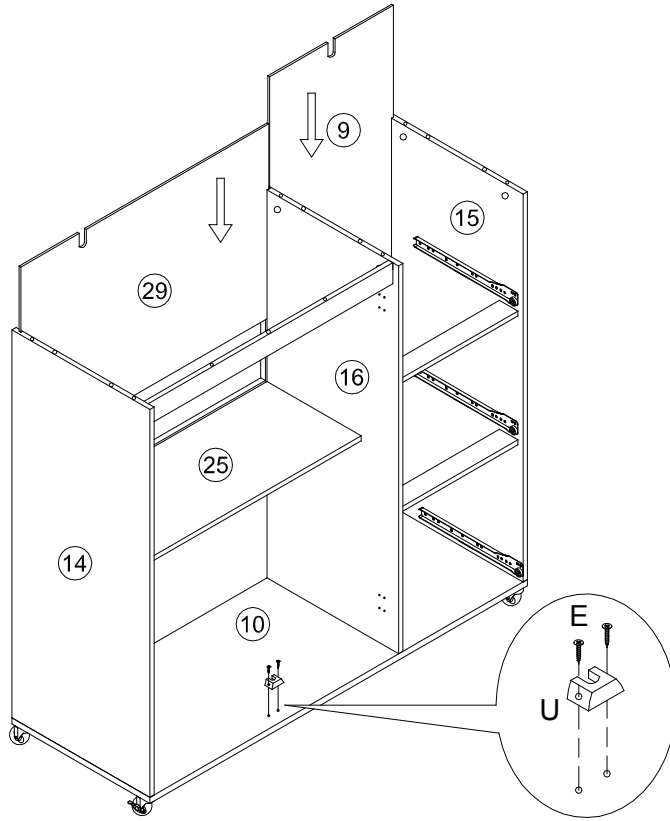

STEP 11/SCHRITT 11/Étapes 11/Passo 11/Paso 11



	
E x 2pcs	U x 1pc

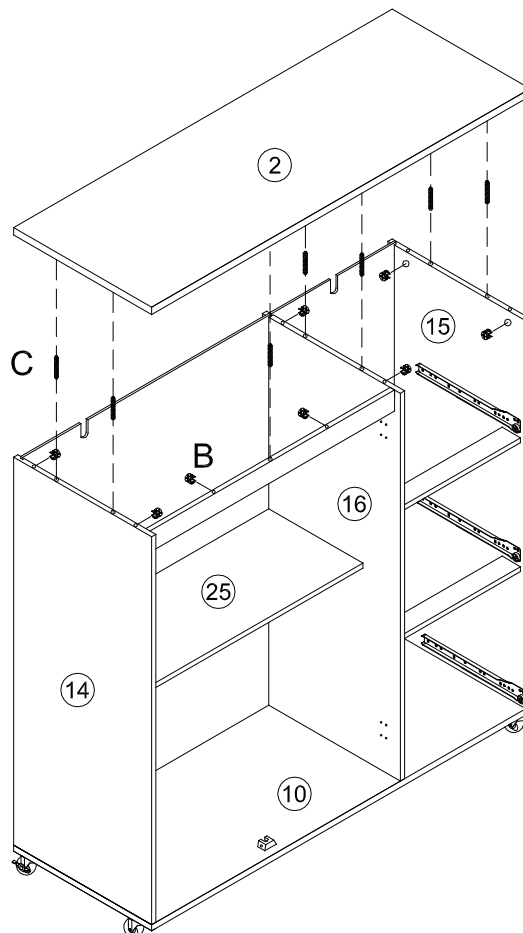

STEP 12/SCHRITT 12/Étapes 12/Passo 12/Paso 12



	
B x 8pcs	C x 7pcs

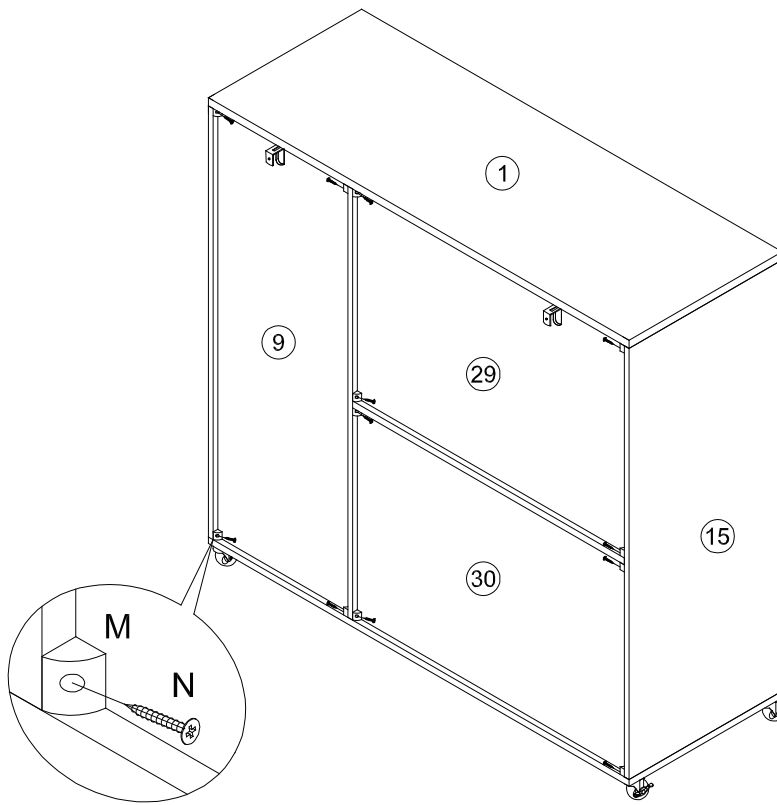

STEP 13/SCHRITT 13/Étapes 13/Passo 13/Paso 13

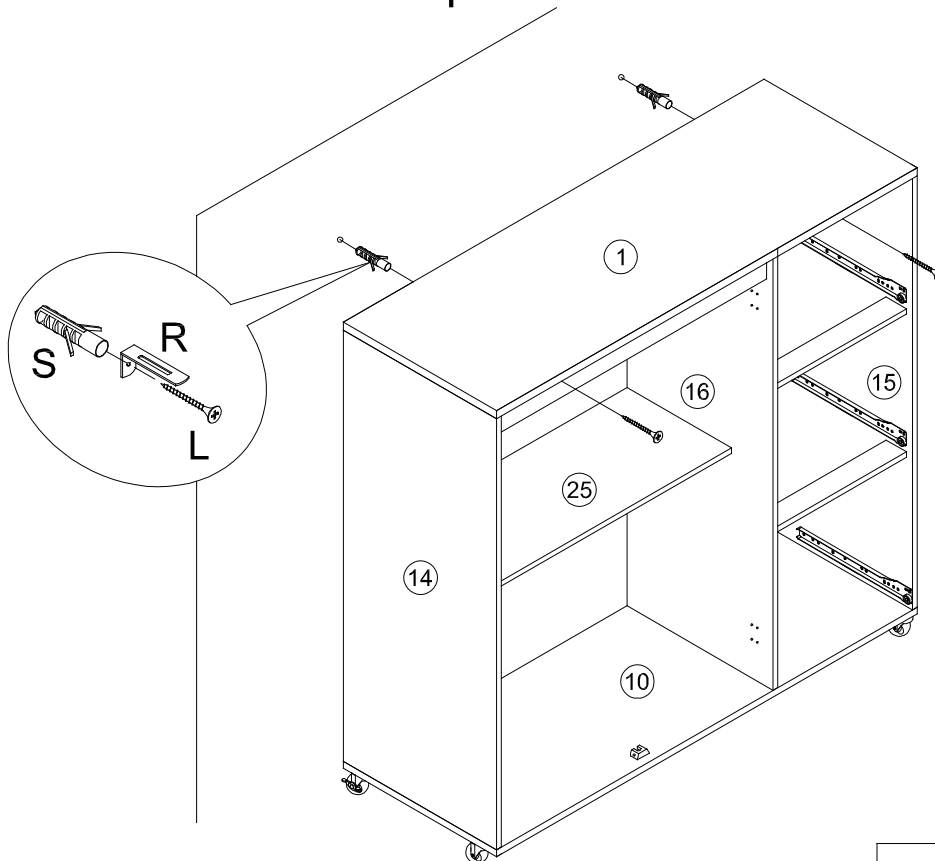

	
M x 12pcs	N x 12pcs

STEP 14/SCHRITT 14/Étapes 14/Passo 14/Paso 14



	
L x 2pcs	S x 2pcs

**STEP 15/SCHRITT 15/
 Étapes 15/Passo 15/Paso 15**

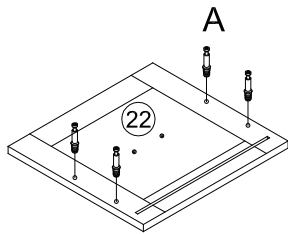

X3

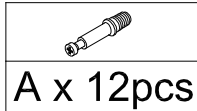

**STEP 16/SCHRITT 16/
 Étapes 16/Passo 16/Paso 16**

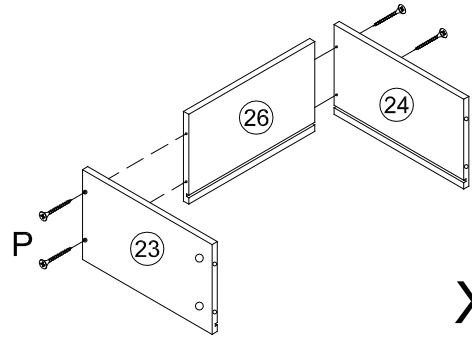

X3

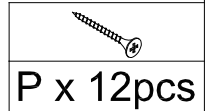

**STEP 17/SCHRITT 17/
 Étapes 17/Passo 17/Paso 17**

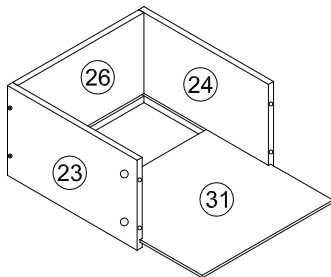

X3

**STEP 18/SCHRITT 18/
 Étapes 18/Passo 18/Paso 18**

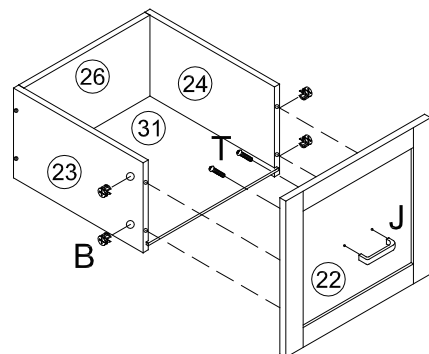

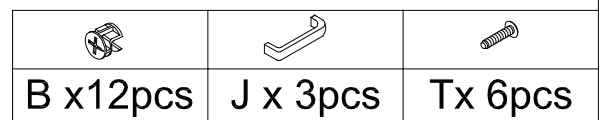

X3

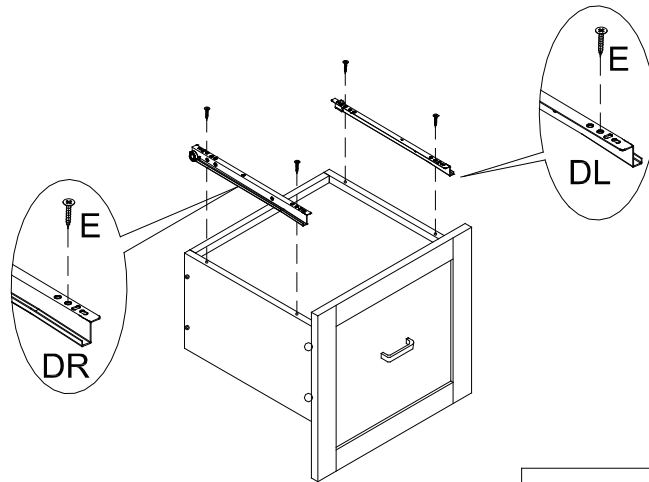
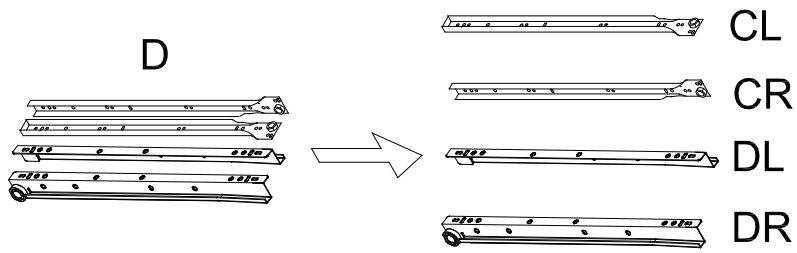

STEP 19/SCHRITT 19/Étapes 19/Passo 19/Paso 19



X3

		
E x 12pcs	DL x 3pcs	DR x 3pcs

STEP 20/SCHRITT 20/Étapes 20/Passo 20/Paso 20

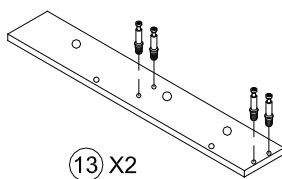
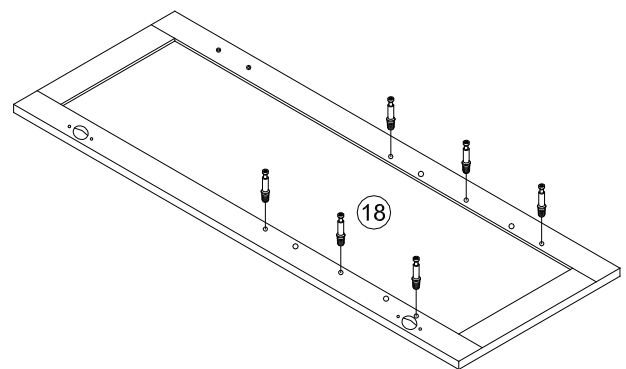
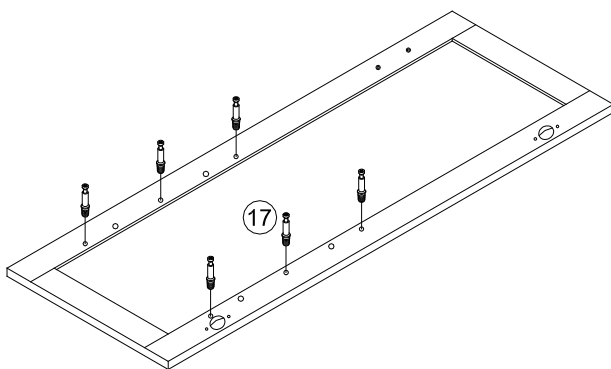

13 X2

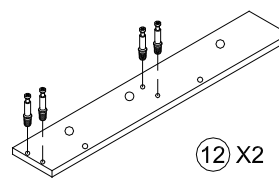

12 X2

A x 28pcs

**STEP 21/SCHRITT 21/
 Étapes 21/Passo 21/Paso 21**

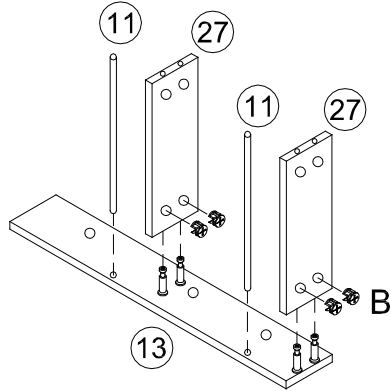

X2

B x 8pcs

**STEP 22/SCHRITT 22/
 Étapes 22/Passo 22/Paso 22**

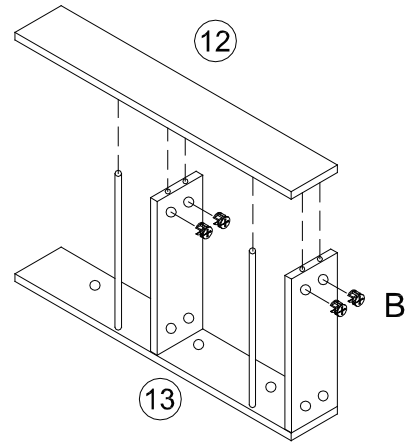



X2

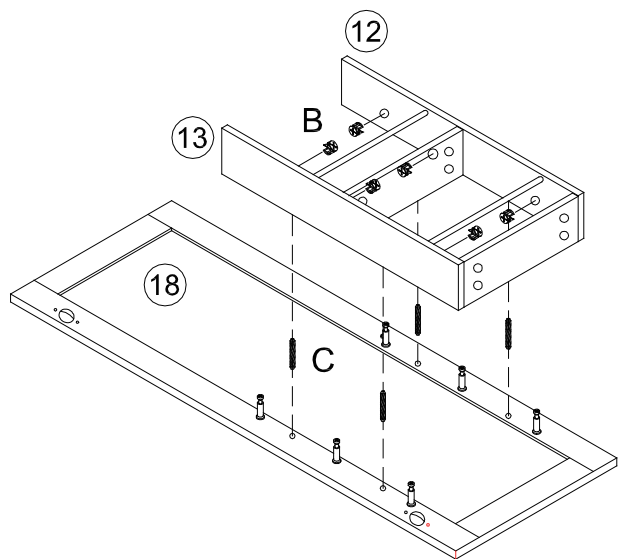
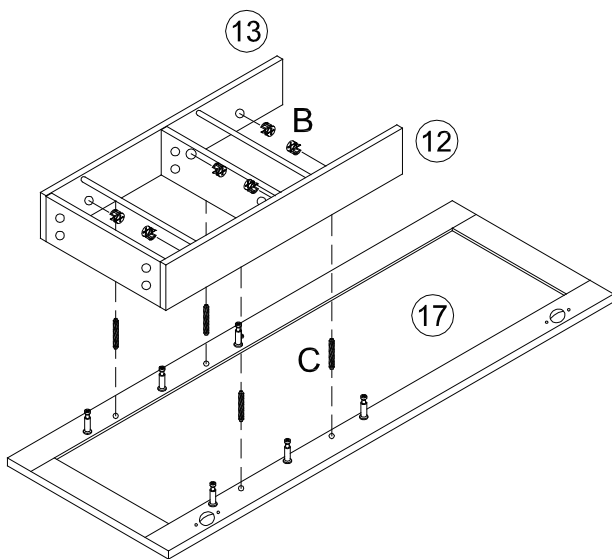

B x 8pcs



STEP 23/SCHRITT 23/Étapes 23/Passo 23/Paso 23

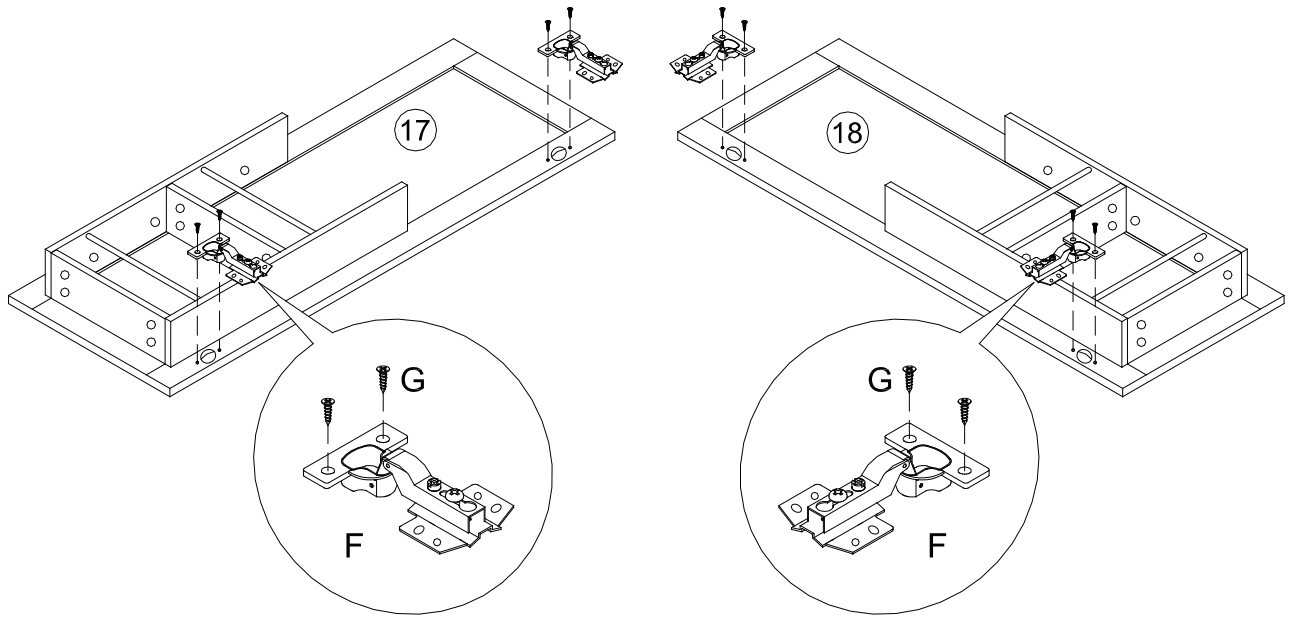

	
B x 12pcs	C x 8pcs

STEP 24/SCHRITT 24/Étapes 24/Passo 24/Paso 24



	
G x 8pcs	F x 4pcs

STEP 25/SCHRITT 25/Étapes 25/Passo 25/Paso 25

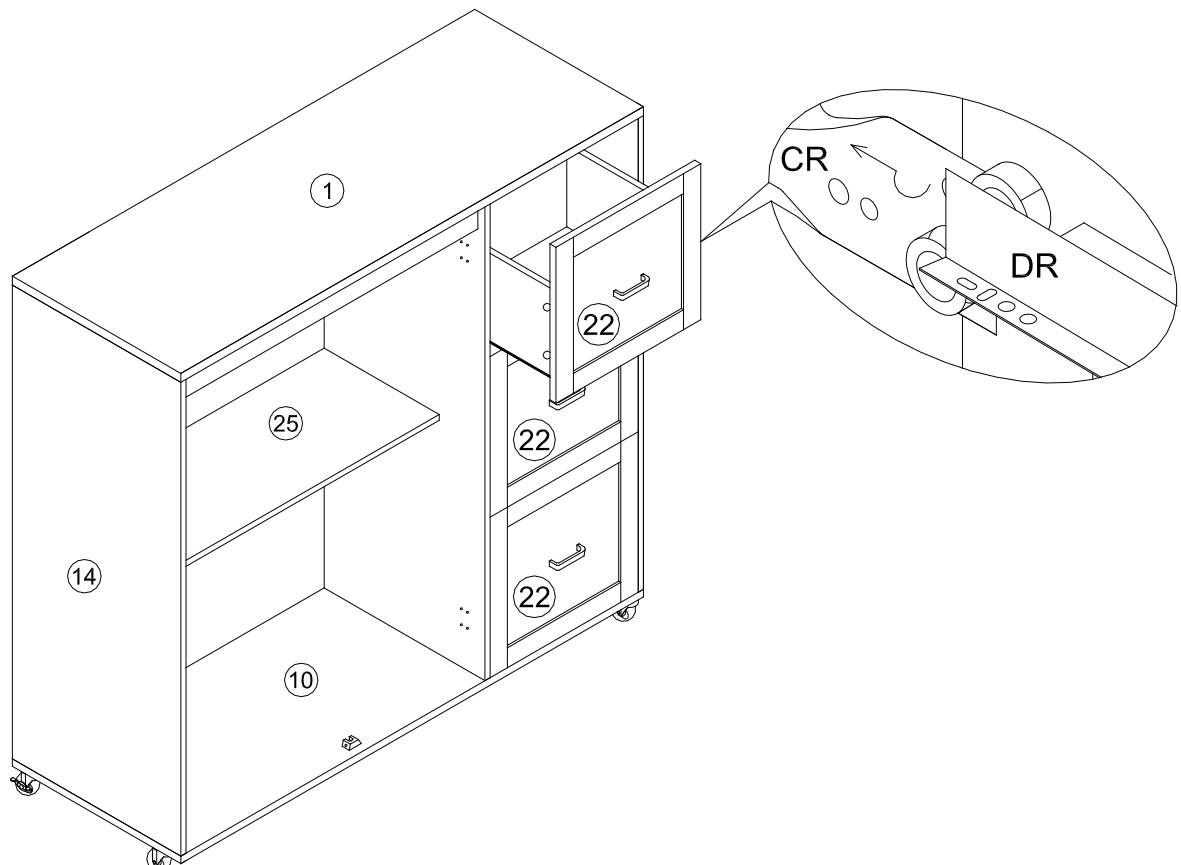

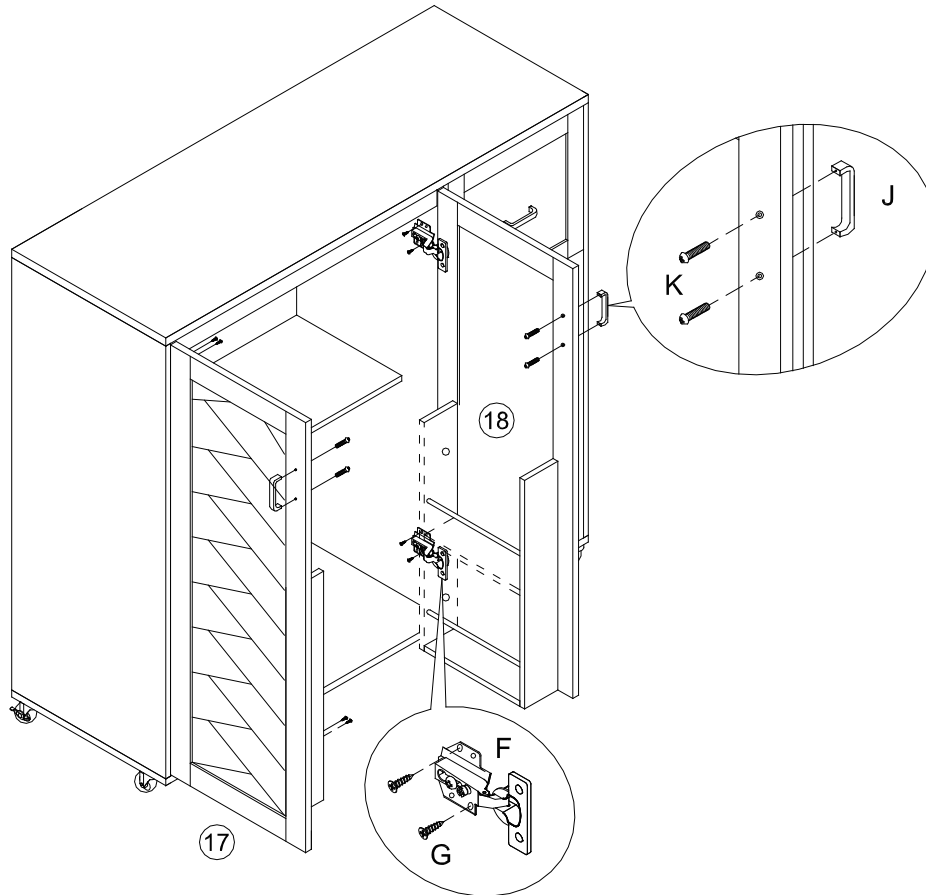

STEP 26/SCHRITT 26/Étapes 26/Passo 26/Paso 26

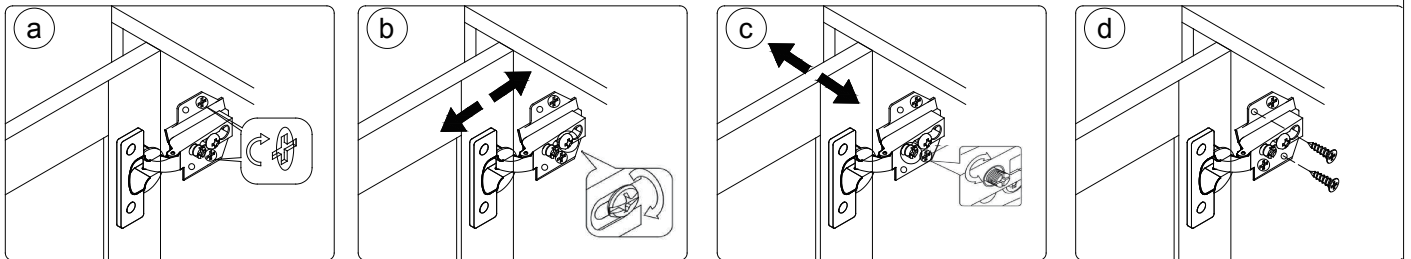

- When the hinges are installed, you can refer to the pictures to adjust crevice of the doors till it's perfect:
- Wenn die Scharniere installiert sind, können Sie sich die Bilder ansehen, um den Spalt der Türen anzupassen, bis es perfekt ist:
- Lorsque la charnière est installée, vous pouvez vous référer à l'image pour ajuster la fente de la porte jusqu'à ce qu'elle soit parfaite:



1. To adjust the doors up and down, please refer to step (a)
 2. To adjust the distance between the doors and side panels, please refer to step (b)
 3. To adjust the gap between two doors, please refer to step (c)
 4. After the adjustment finished, please tight the screws, refer to step (d)
1. Um die Türen nach oben und unten einzustellen, siehe Schritt (a)
 2. Um den Abstand zwischen den Türen und den Seitenwänden einzustellen, lesen Sie bitte Schritt (b)
 3. Um den Abstand zwischen zwei Türen einzustellen, siehe Schritt (c)
 4. Nachdem die Einstellung beendet ist, ziehen Sie bitte die Schrauben fest, siehe Schritt (d)
1. Pour régler les portes de haut en bas, reportez - vous à l'étape (A)
 2. Pour régler la distance entre la porte et le panneau latéral, reportez - vous à l'étape (b)
 3. Pour régler l'écart entre les deux portes, reportez - vous à l'étape (c)
 4. Une fois le réglage terminé, serrez les vis, voir étape (d)

		
G x 16pcs	J x 2pcs	K x 4pcs

STEP 27/SCHRITT 27/Étapes 27/Passo 27/Paso 27

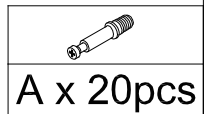
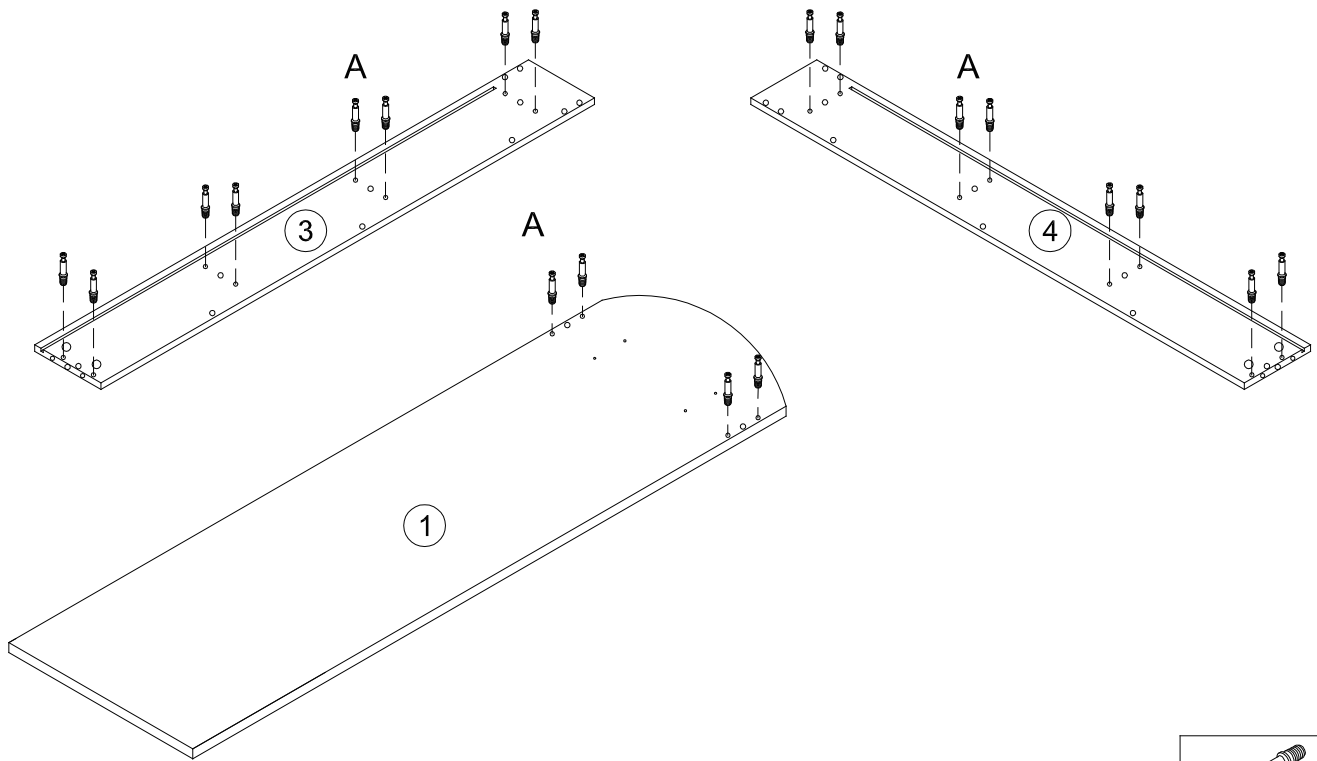

**STEP 28/SCHRITT 28/
 Étapes 28/Passo 28/Paso 28**

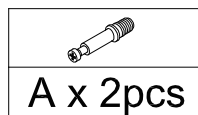
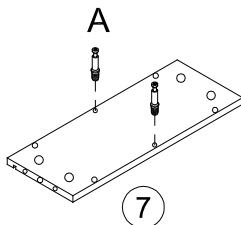

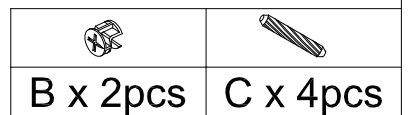
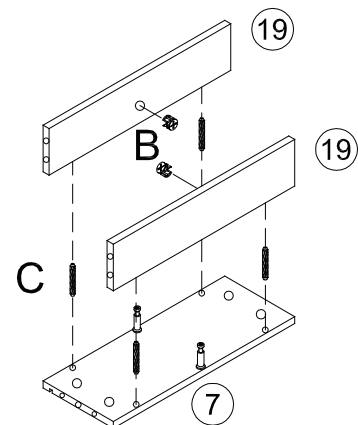

**STEP 29/SCHRITT 29/
 Étapes 29/Passo 29/Paso 29**

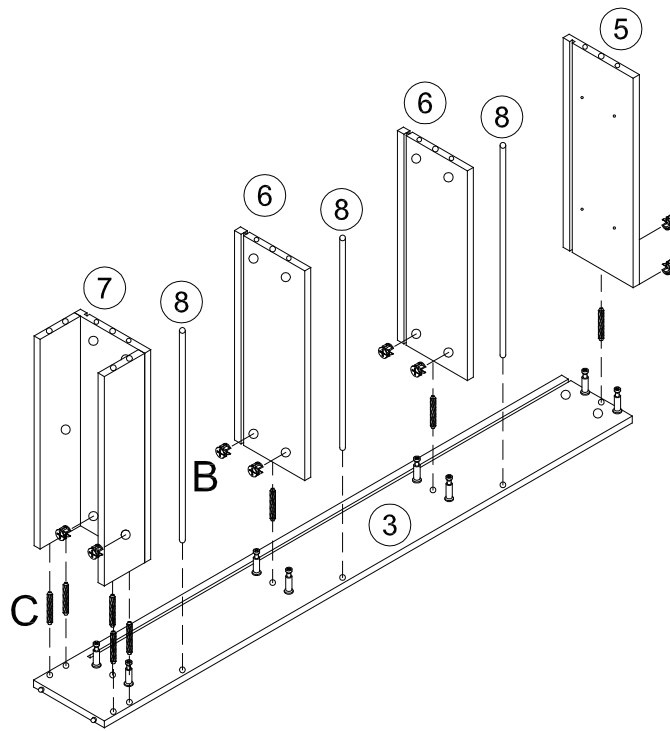

STEP 30/SCHRITT 30/Étapes 30/Passo 30/Paso 30



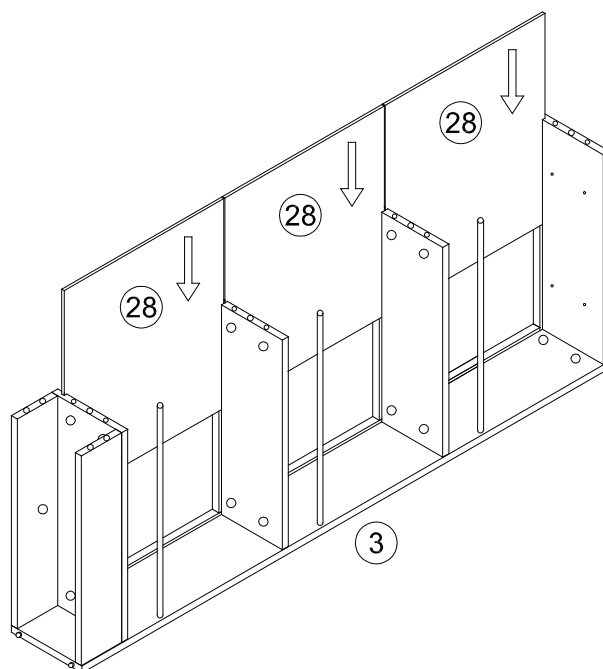

	
B x 8pcs	C x 8pcs

STEP 31/SCHRITT 31/Étapes 31/Passo 31/Paso 31



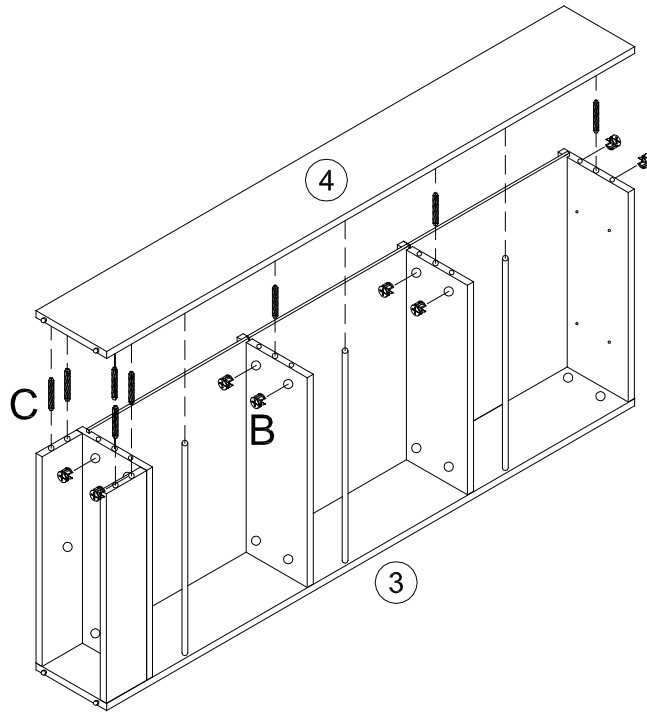

STEP 32/SCHRITT 32/Étapes 32/Passo 32/Paso 32



	
B x 8pcs	C x 8pcs

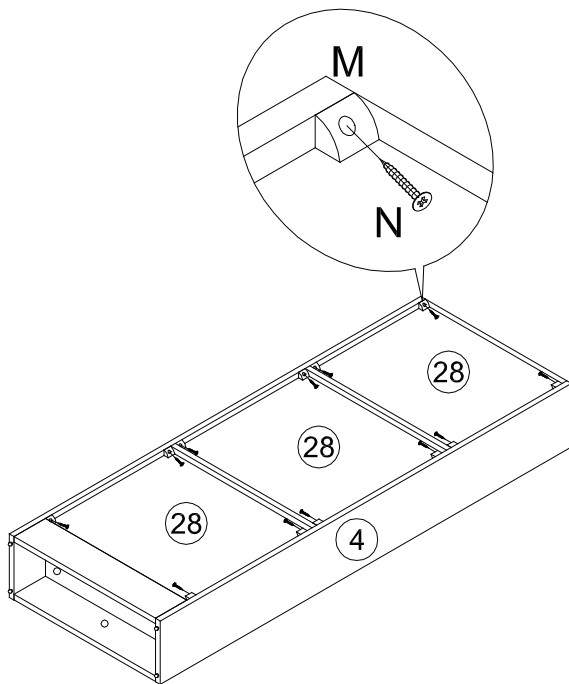

**STEP 33/SCHRITT 33/
Étapes 33/Passo 33/Paso 33**

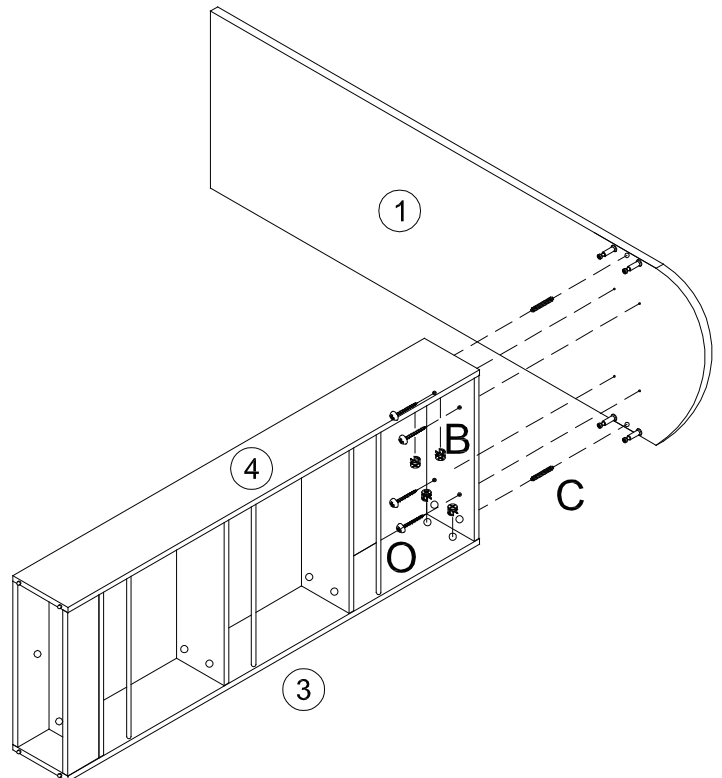

	
M x 12pcs	N x 12pcs

**STEP 34/SCHRITT 34/
Étapes 34/Passo 34/Paso 34**



		
B x 4pcs	C x 2pcs	O x 4pcs

STEP 35/SCHRITT 35/Étapes 35/Passo 35/Paso 35

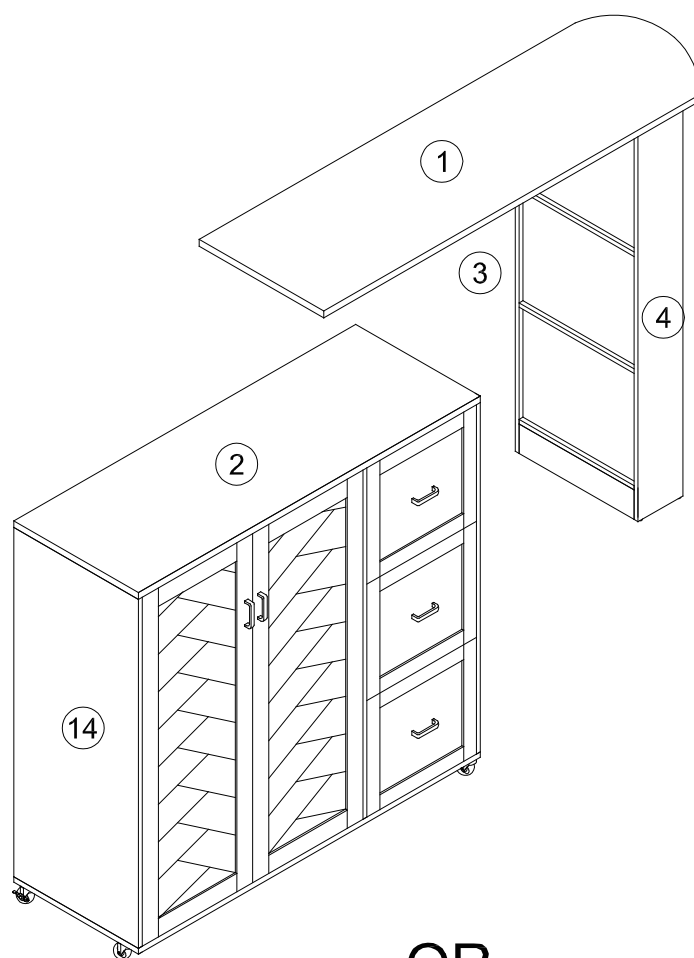

OR

