

Assembly Instructions

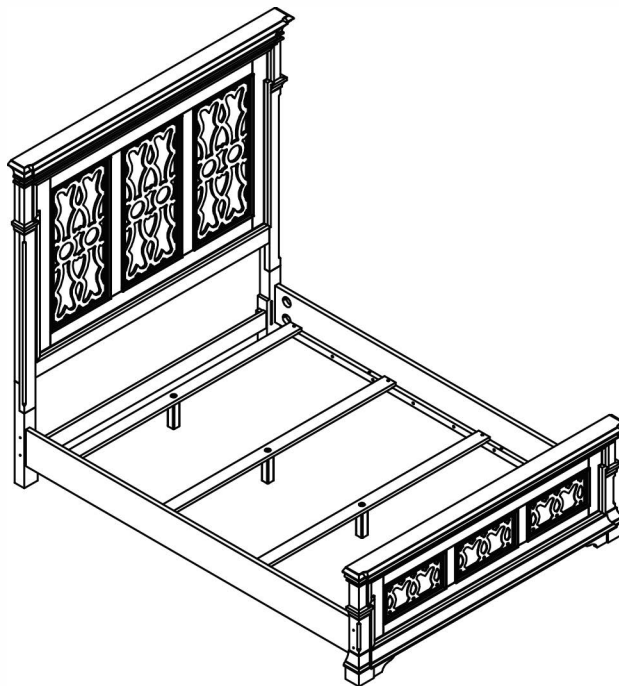

ASSEMBLY RATING

The Assembly Rating is a 5-point system that shows the degree of effort needed in assembling a specific product (with 1 being easy and 5 being difficult). For some products, two persons are recommended.

EASY



DIFFICULT

Tools Required For Assembly:

Allen Wrench



(Included)

Wrench



(Included)

Phillips Screwdriver



(Not Included)



2 PERSONS RECOMMENDED

ASSEMBLY & CARE ADVICE

FOR YOUR FURNITURE TO LAST, CORRECT ASSEMBLY AND PROPER MAINTENANCE ARE NECESSARY. PLEASE FOLLOW THE INFORMATION PROVIDED BELOW TO FULLY ENJOY YOUR FURNITURE.

BASIC ASSEMBLY TECHNIQUES

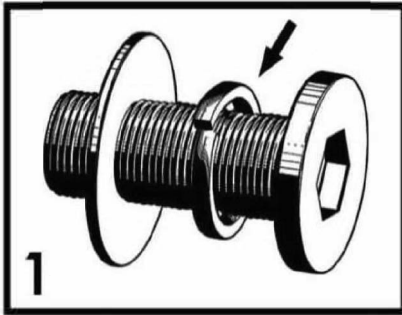

1
When lock or spring washer is used in an assembly, please make sure the lock or spring washer is placed between the larger flat washer and the head of the screw or bolt.

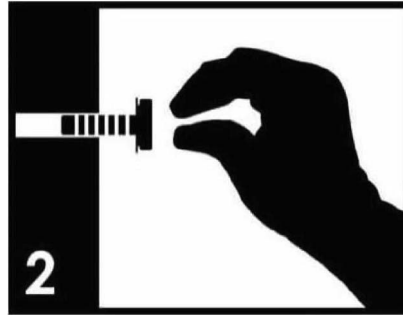

2
Position each part correctly and insert screws or bolts into their respective holes by hand tighten or using the proper hand tool. Only tighten when step is completed or when instructed to do so.

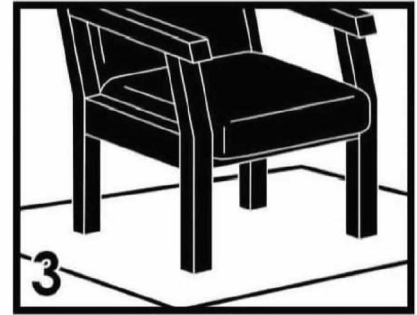

3
Use cardboard or carpet area when assembling furniture to prevent scratches. Make sure the furniture rests on a flat and level surface with each leg evenly touching the floor.

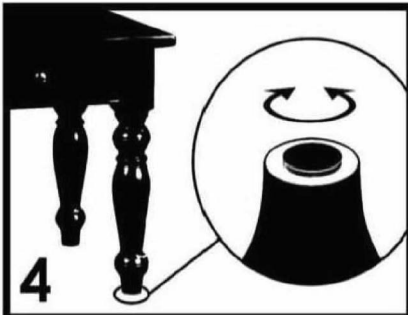

4
Some furniture comes with height adjustment knobs underneath each leg. To lower or to raise each leg, you need to turn clockwise or counterclockwise, respectively.

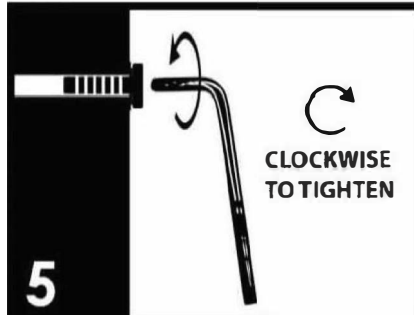

5
Make sure all parts are properly aligned, then use the appropriate hand tool to completely tighten the bolts or screws. Do not use power tools and do not over-tighten.

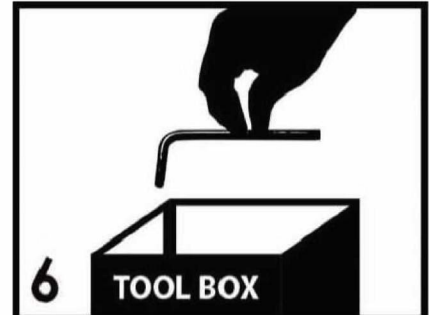

6
Save the instructions and store the Allen wrench or any supplied tool for later maintenance. After two weeks, check and tighten any loose hardware and repeat again every six months thereafter.

IT IS THE USER'S RESPONSIBILITY TO MAINTAIN THE FURNITURE. THE HARDWARE MAY LOOSEN OVER TIME AND MAY CAUSE THE FURNITURE TO BE WOBBLY AND UNABLE TO SUPPORT ITS INTENDED WEIGHT CAPACITY. THIS MAY LEAD TO COLLAPSE AND MAY CAUSE SERIOUS INJURY.

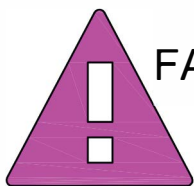



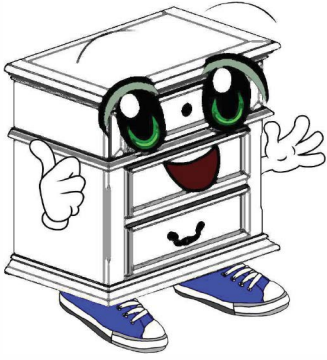

FAILURE TO FOLLOW THE GUIDELINES ABOVE MAY RESULT IN INJURY AND/OR PROPERTY DAMAGE.







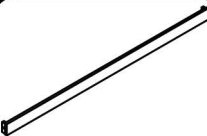
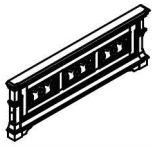
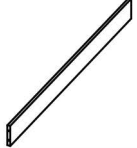
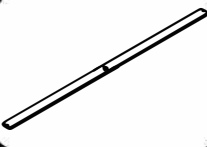





Before you begin, please read Page 2 of "Assembly and Care Advice".

And remember, do not tighten until each step is completed or instructed.

Parts List

	#1 x 1 pc Headboard
	#2R x 1 pc Right H/Board Leg
	#2L x 1 pc Left H/Board Leg
	#3 x 1 pc Leg Support
	#4 x 1 pc Footboard
	#6 x 2 pcs Side Rail
	#7 x 4 pcs Slat
	#8 x 4 pcs Slat Support Leg 40x40x147mm
	#K x 4 pcs Wood Dowel

Hardware List

	#A x 2 pcs Bolt 1/4" x 1-4/8"
	#B x 6 pcs Bolt 1/4" x 1-6/8"
	#C x 8 pcs Lock Washer
	#D x 8 pcs Flat Washer
	#E x 1 pc Allen Wrench
	#F x 8 pcs Threaded Stud
	#G x 8 pcs Hex Nut
	#H x 8 pcs Beveled Washer
	#I x 1 pc Wrench
	#J x 4 pcs Screw 1-1/4"



Note : Left and rights is determined bu facing the front of the headboard in its upright position.

- #A x 2 pcs
- #C x 2 pcs
- #D x 2 pcs
- #K x 4 pcs

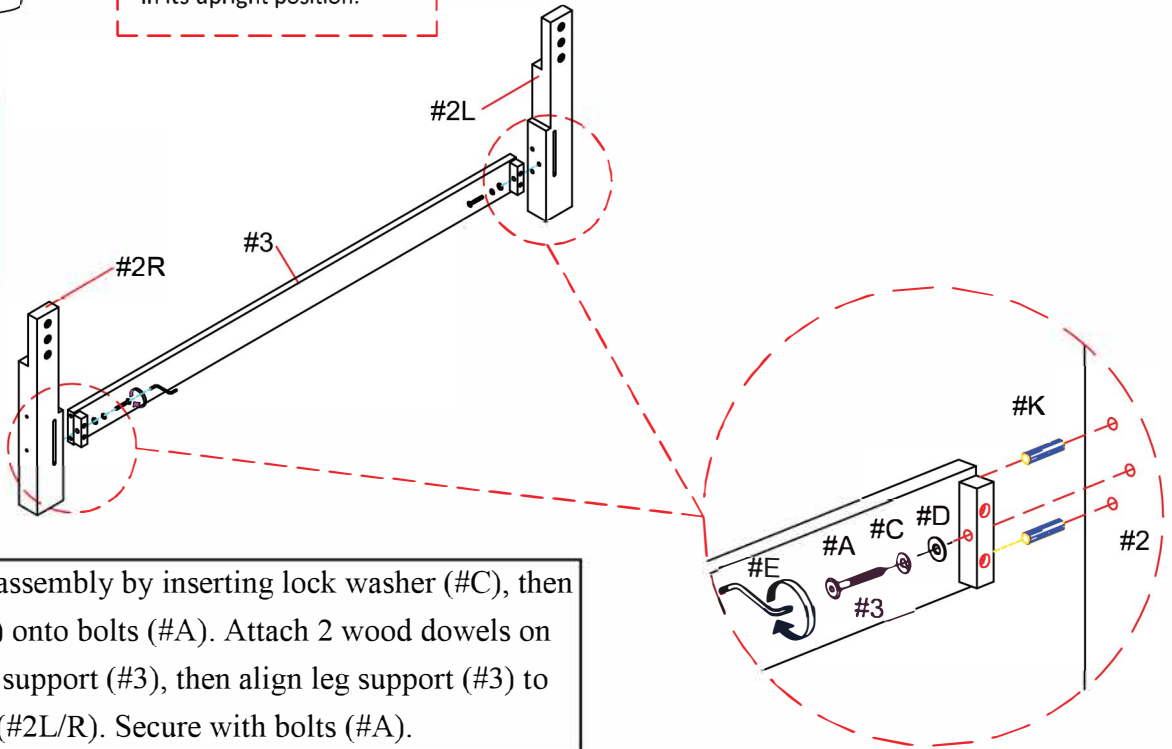

Prepare 2 bolts assembly by inserting lock washer (#C), then flat washer (#D) onto bolts (#A). Attach 2 wood dowels on each side of leg support (#3), then align leg support (#3) to headboard legs (#2L/R). Secure with bolts (#A).



- #B x 6 pcs
- #C x 6 pcs
- #D x 6 pcs

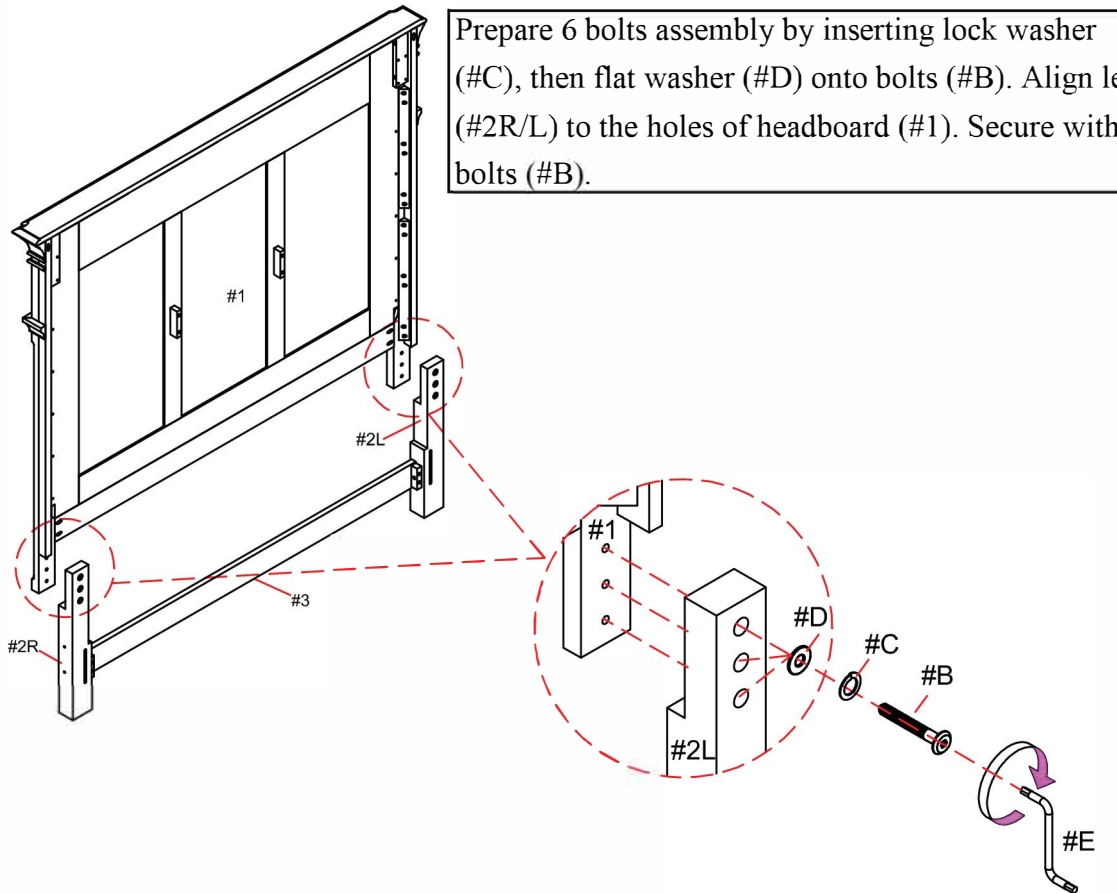

Prepare 6 bolts assembly by inserting lock washer (#C), then flat washer (#D) onto bolts (#B). Align legs (#2R/L) to the holes of headboard (#1). Secure with bolts (#B).



Attach the threaded studs (#F) to the legs (#2R/L) and footboard (#4). Insert beveled washer (#H) and hex nut (#G) into side rails (#6). Align the studs (#F) to the hex nut (#G) inside of the side rails (#6). Secure using a wrench (#I).

- #F x 8 pcs
- #G x 8 pcs
- #H x 8 pcs

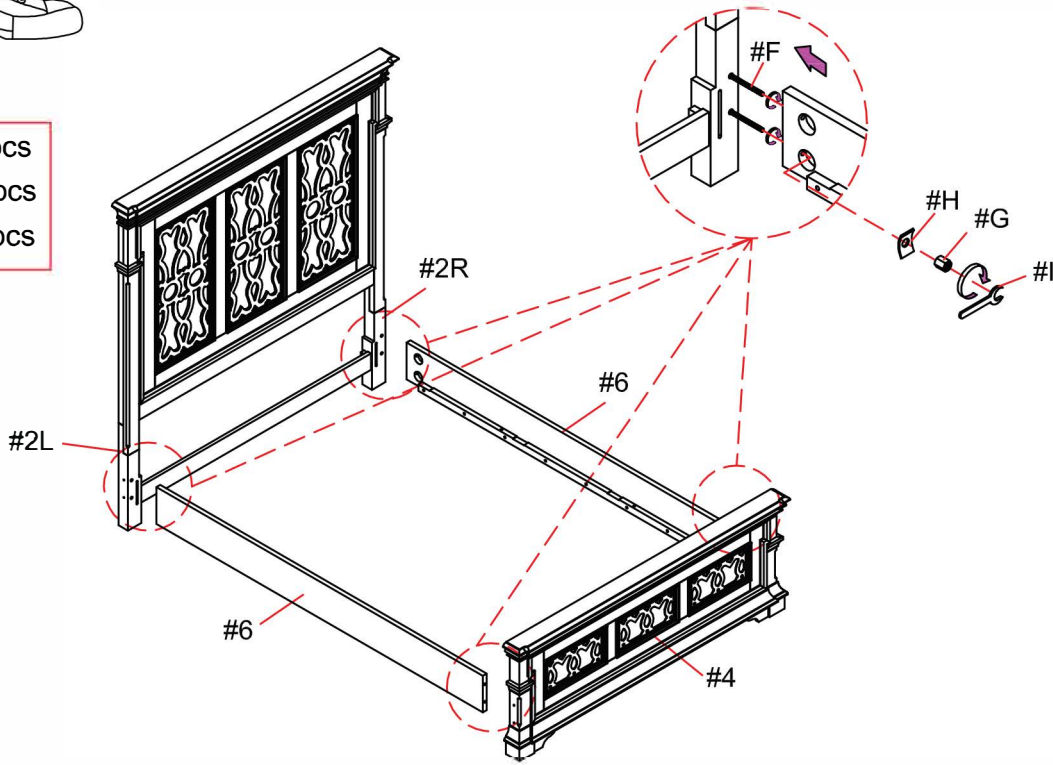

Attach slat support legs (#8) to the slats (#7).

X4

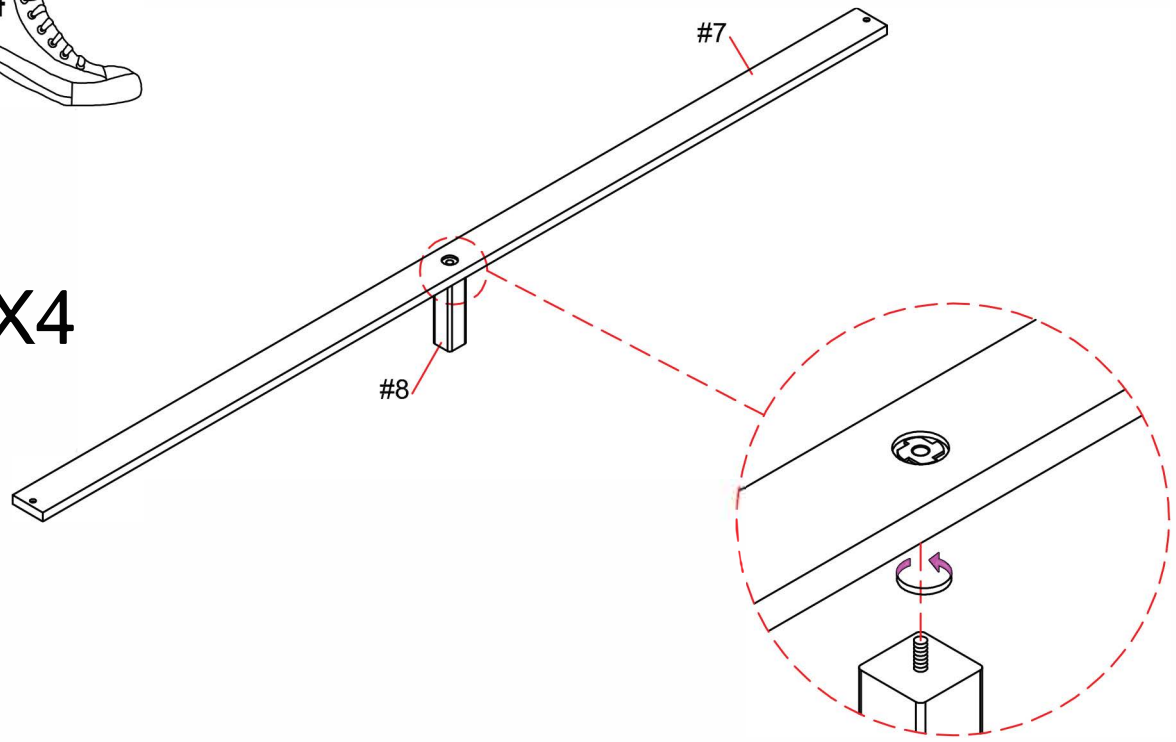



Align slats (#7) to the holes of the side rails. Secure with screws (#J).

#J x 4 pcs

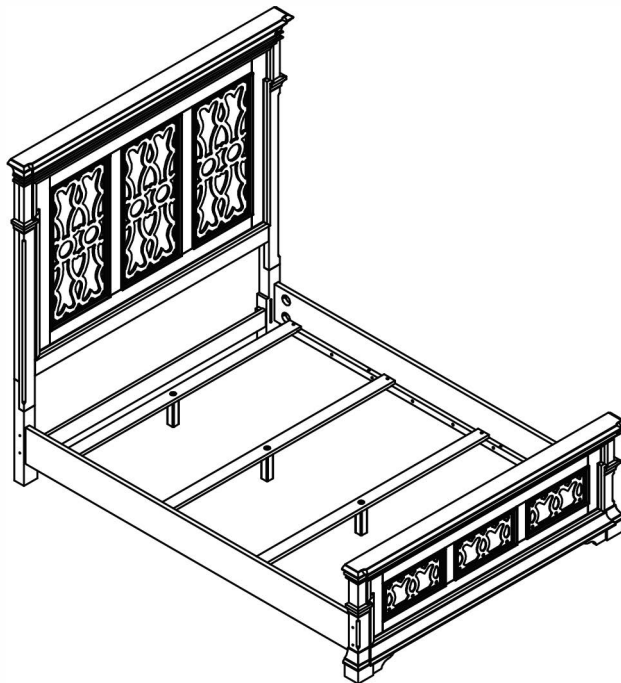
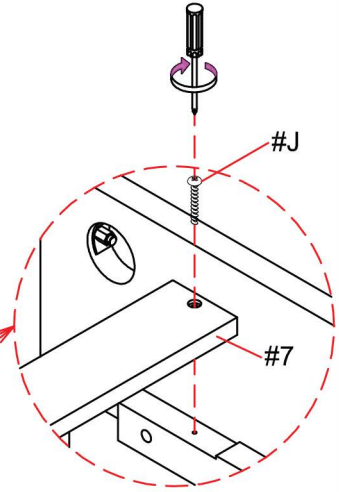
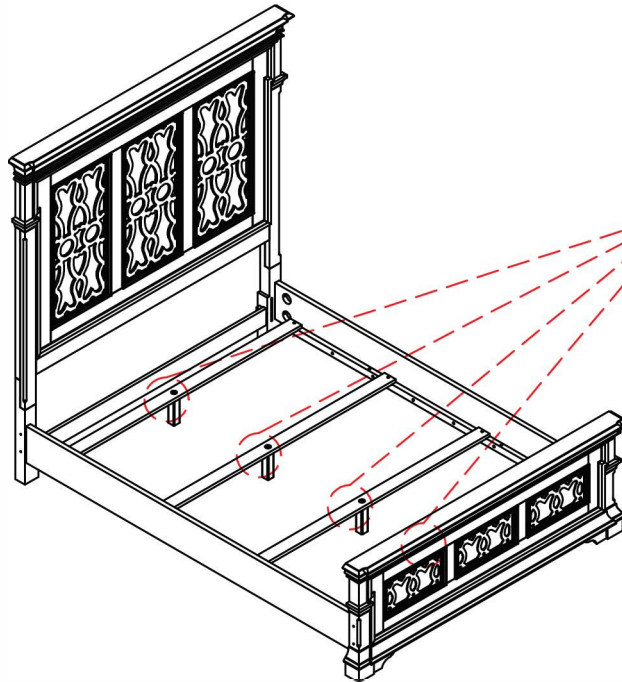

ASSEMBLY IS COMPLETED