

# ASSEMBLY INSTRUCTIONS

## DINING CHAIR

ASSEMBLY  
REQUIREMENTS

2-Person  
Assembly

30 MINUTES  
Assembly Time  
Approximate

Tools Required  
(Not Provided)



Mallet

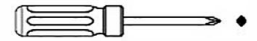

Phillips Screwdriver

### Thank you for purchasing our product!

Please refer and use this assembly instruction to assemble the product.

We appreciate your business!

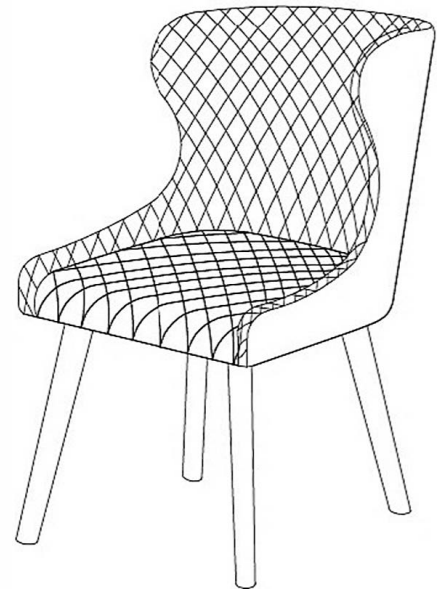

### ASSEMBLY PREPARATION

1. Remove all packaging materials, staples and packing straps from the carton.
2. Refer to Parts List and Hardware List. Ensure parts and hardware are complete before assembling the product.
3. Contact customer service for missing parts.
4. Place all wooden parts on a clean, flat and soft surface (e.g. carpet or rug) to prevent parts from getting scratched.

### SAFETY PRECAUTION

1. KEEP ALL HARDWARE PARTS OUT OF REACH OF CHILDREN.
2. DISPOSE PLASTIC PACKAGING MATERIAL IMMEDIATELY TO AVOID ANY RISK OF SUFFOCATION TO CHILDREN AND ANIMALS.

### TIPS FOR ASSEMBLY

1. Allow ample room for assembly and in close proximity to where product will be placed.
2. Assemble the product on a surface that does not scratch or damage the exterior gloss and finish of the furniture.
3. Check all of the parts and quantities are included before assembly.
4. Identify all of the parts, hardware and quantities required for each step.
5. During assembly, do not over-tighten any fittings as this may cause damage.
6. DO NOT USE POWER TOOLS TO ASSEMBLE THIS PRODUCT.
7. Always place the product on a flat, level surface.
8. Do not sit or stand on the partially assembled product; only use the product for which it is intended.

### CARE AND MAINTENANCE





- Use a slightly damp cloth to clean the product. Do not use bleach or abrasive cleaning material.
- Check all the fittings periodically and re-tighten as necessary. Do not use the product if any of the parts is damaged or broken.
- Never allow any kind of liquid to remain on your furniture. Absorption can cause wood to warp or delaminate.
- Do not place hot items (e.g. hot drinks) directly onto the wood surface.
- Do not drag and/or pull the furniture.

This product is for indoor and household use only - not for commercial use.





# ASSEMBLY INSTRUCTIONS

## DINING CHAIR

### PART LIST

Item	Description	Part	Qty
1	Chair Body		1
2	Leg Left		1
3	Leg Right		1
4	Corner Block -Short		1
5	Corner Block -Long		1

### HARDWARE LIST

Item	Description	Part	Qty
A	JCBC M6 X 60mm		4
B	Spring Washer M6 X 13mm		4
C	CSK Screw M4 X 28mm		8
D	Allen Key		1
E	Leg Stud		4

### STEP 1

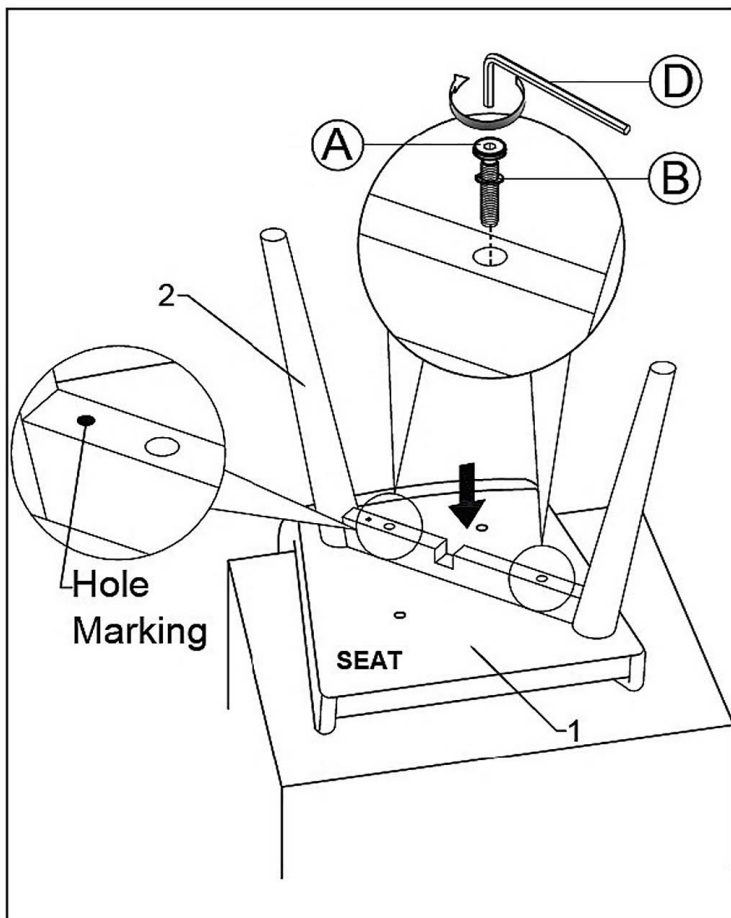

- Place Chair Body (1) bottom-side up on an elevated surface (e.g. table top) as shown.
- Position Left Leg (2) diagonally and align the screw holes on (2) to the diagonal screw holes on the bottom-side of the seat. (Note: the Hole Marking is towards the rear edge of the seat.)
- Insert Screw (A) fitted with Spring Washer (B) into screw hole on (2).
- Use Allen Key (D) to drive (A) to fasten (2) to bottom-side of seat. Do not tighten (A) completely until both screws are in place on each leg. Do not over-tighten the screws.

### STEP 2

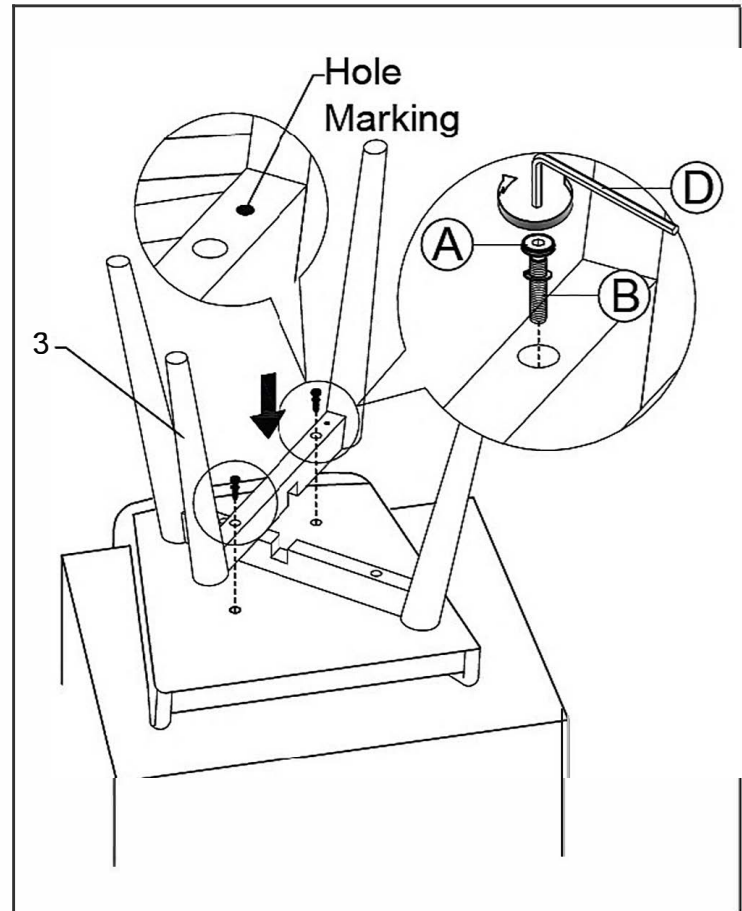

- Position Right Leg (3) diagonally to mate its half lap joint to the half lap joint on (2) to form a crossed half lap joint as shown. (Note: the Hole Marking is towards the rear edge of the seat.)
- Insert Screw (A) fitted with Spring Washer (B) into screw hole on (3).
- Use Allen Key (D) to drive (A) to fasten (3) to bottom-side of seat. Do not tighten (A) completely until both screws are in place on each leg. Do not over-tighten the screws.

# ASSEMBLY INSTRUCTIONS

## DINING CHAIR

### STEP 3

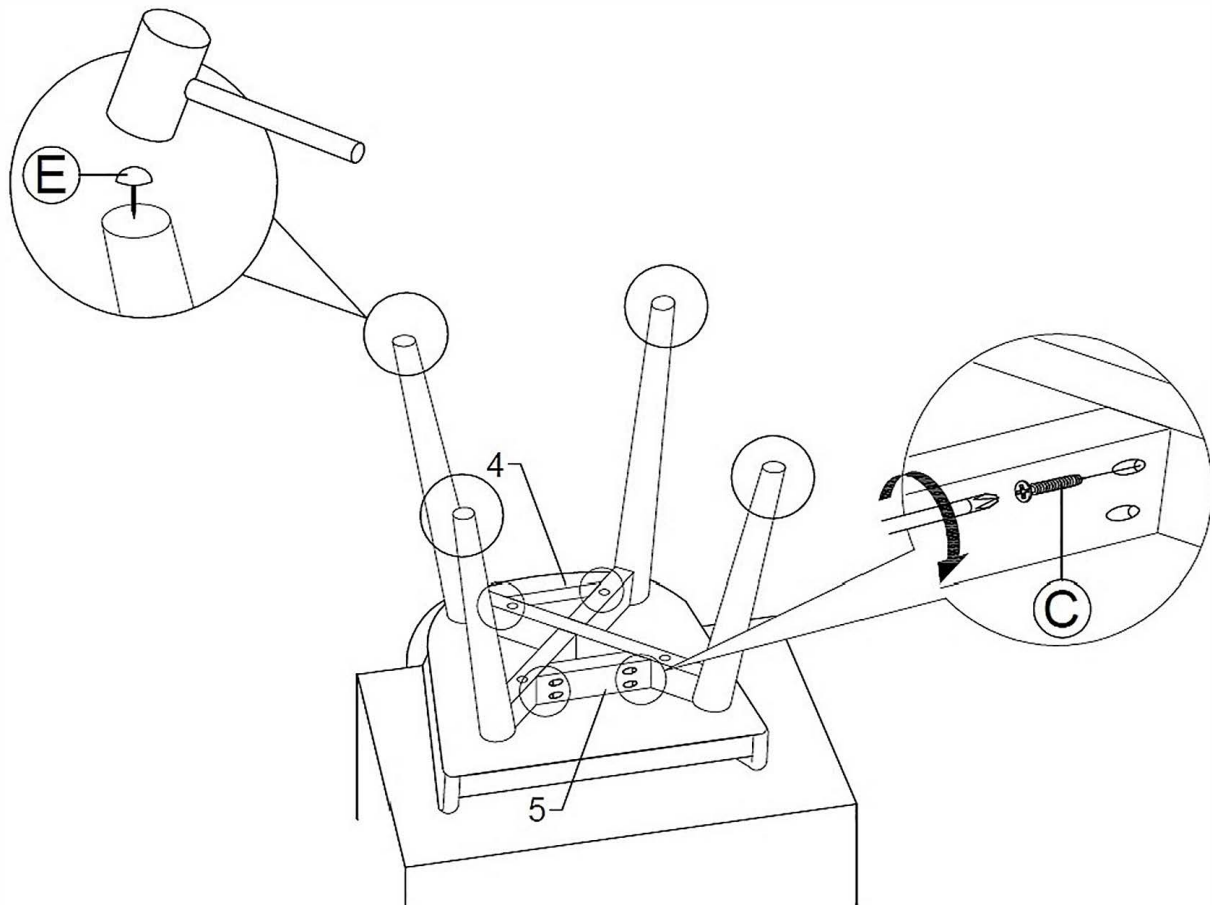

- Fit Corner Block (4 & 5) between and against the Leg Rails of (2 & 3).
- Use a Phillips Screwdriver to drive Screw (C) to fasten (4 & 5) to the Leg Rails of (2 & 3).  
Do not tighten the screws completely until both screws are in place on corner block.  
Do not over-tighten the screws.
- Use a mallet or hammer to gently nail Leg Stud (E) into each end of the leg.

Position the chair right-side up. The assembly of the Chair is complete.