

**DGRT-V1**

**FTLFKT-2036**

**FTLFKT-2037**

**FTLFKT-2038**

**FTLFKT-2039**

# "IMPORTANT, RETAIN FOR FUTURE REFERENCE: READ CAREFULLY"

**Notice:**

1. Follow the installation instructions. Please confirm all accessories are preset before installation.
2. Do not fully tighten the screws during initial assembly. Fully tighten screws only once all pieces which are correctly assembled.
3. If you encounter any problems during installation, please contact our customer service.
4. Please unbox the item from the side with an open-label and put carpet on the floor to avoid scratching it.





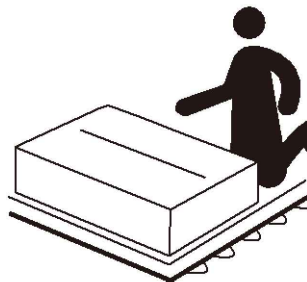

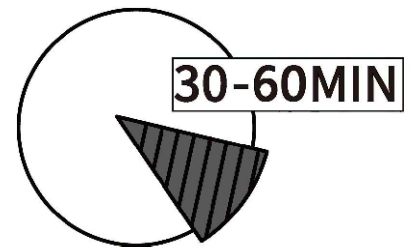

Recommended installers: 2





Put a carpet on the floor before unpcking

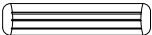



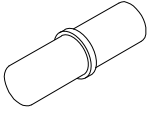
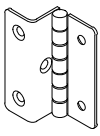
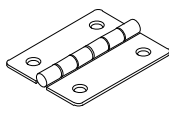
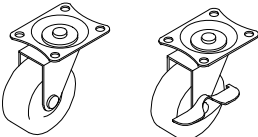
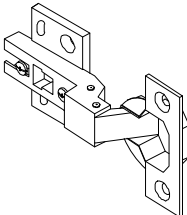
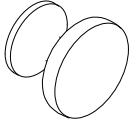
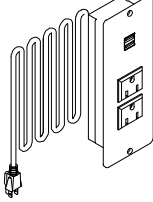
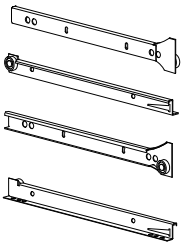
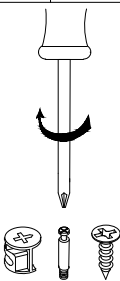

Estimate installation time:  
30-60 minutes

Item no.	Reference Image	Qty.	Item no.	Reference Image	Qty.
<b>A</b>	 ø15*10mm	× 50	<b>B</b>	 M6*34mm	× 50
<b>C</b>	 M5*38mm	× 48	<b>D</b>	 3.5*14mm	× 114
<b>E</b>	 6*30mm	× 50	<b>F</b>	 ø1/4"*25mm	× 14

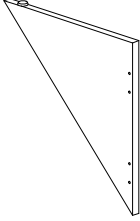
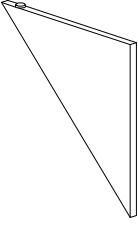
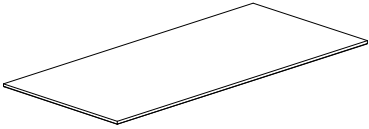
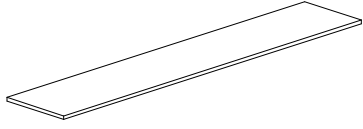
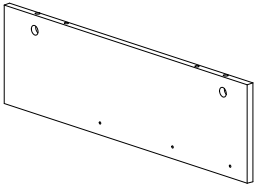
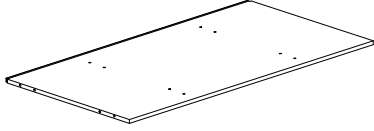
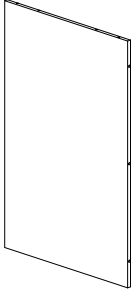

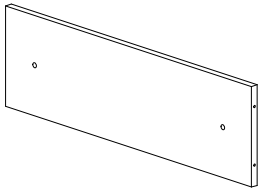
Item no.	Reference Image	Qty.	Item no.	Reference Image	Qty.
<b>G</b>	 ø1/4"*10mm	× 20	<b>H</b>	 M4*14mm	× 7
<b>I</b>	 M4	× 1	<b>J</b>		× 12
<b>K</b>		× 4	<b>L</b>		× 3
<b>M</b>	 × 3    × 2	× 5	<b>N</b>		× 8
<b>O</b>		× 7	<b>P</b>		× 1
<b>Q</b>	 CL DL CR DR	× 3	 <b>Screw driver needed But not included</b>		

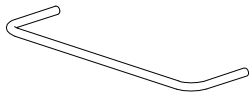
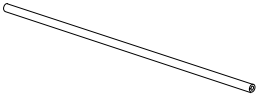
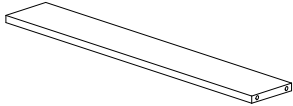
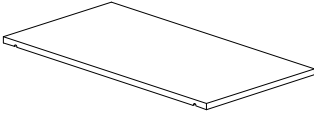
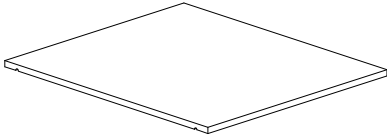
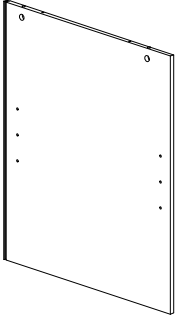
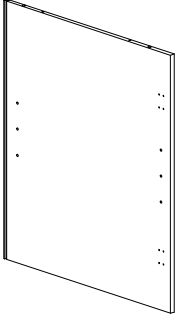
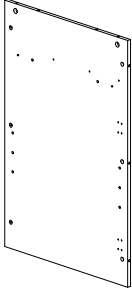
The hardware quantities listed above are required for proper assembly.  
Some extra hardware may also have been included in the actual hardware bag.

Item no.	Reference Image	Qty.	Item no.	Reference Image	Qty.
①		×1	②		×1
③		×1	④		×1
⑤		×2	⑥		×1
⑦		×1	⑧		×1
⑨		×1	⑩		×1

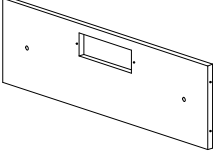
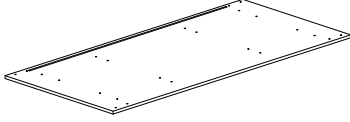
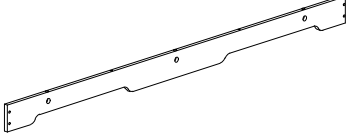
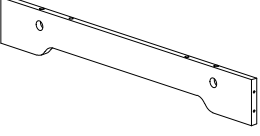
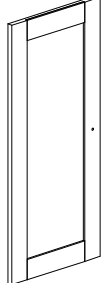
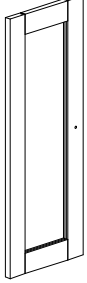
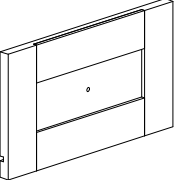
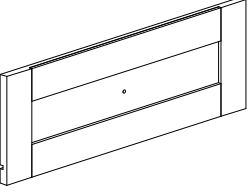
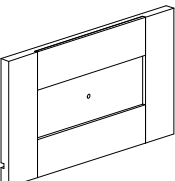
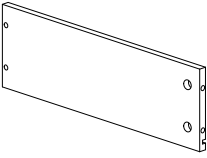
Item no.	Reference Image	Qty.	Item no.	Reference Image	Qty.
11		×2	12		×5
13		×3	14		×2
15		×1	16		×1
17		×1	18		×1
19		×1	20		×1

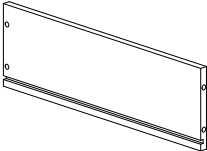
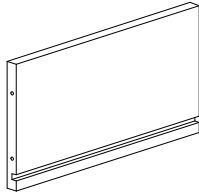
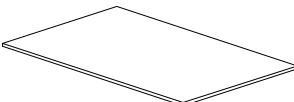
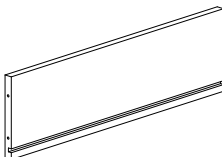
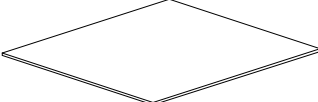
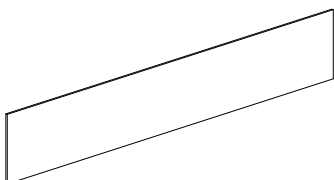

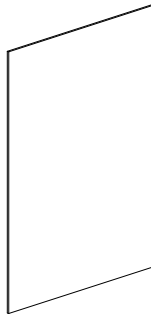
Item no.	Reference Image	Qty.	Item no.	Reference Image	Qty.
21		×1	22		×1
23		×2	24		×2
25		×2	26		×2
27		×1	28		×1
29		×1	30		×3

Item no.	Reference Image	Qty.	Item no.	Reference Image	Qty.
31		× 3	32		× 2
33		× 2	34		× 1
35		× 1	36		× 1
37		× 2	38		× 1

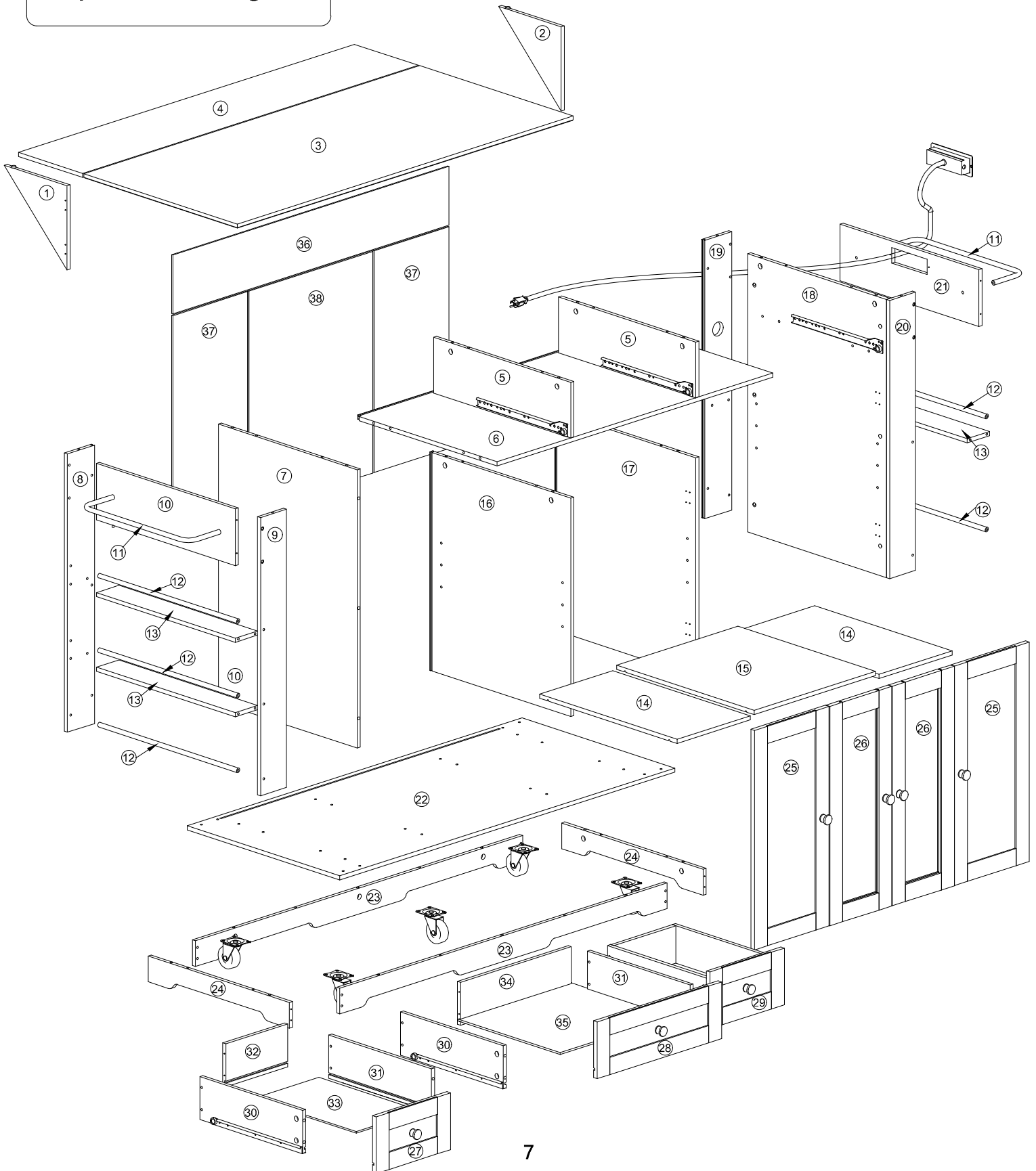
# Explosion Diagram

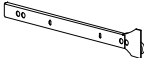
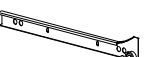
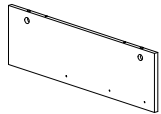

# 1

- D** 18 pcs 
- Q**  CL\*3  CR\*3
- 5** 2 pcs 
- 7** 1 pc 
- 18** 1 pc 

SCREW DRIVER NOT INCLUDED

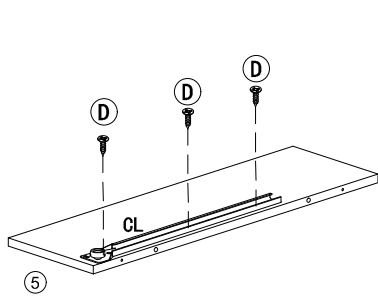
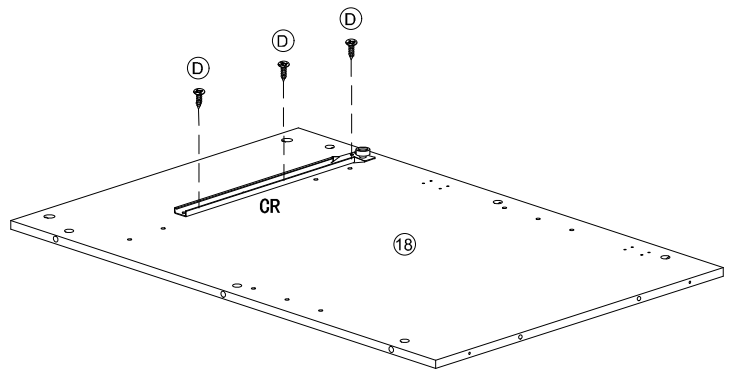
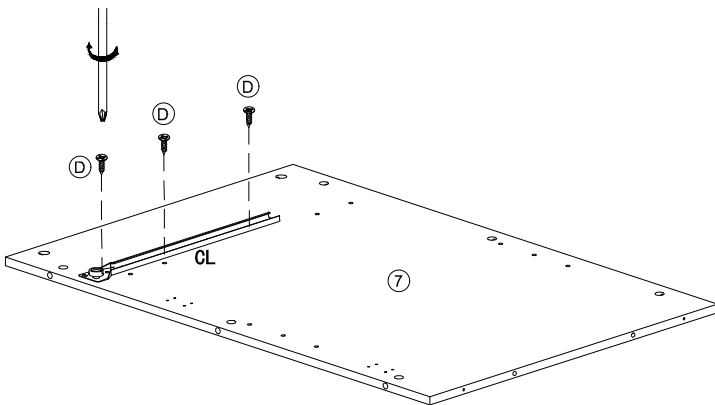
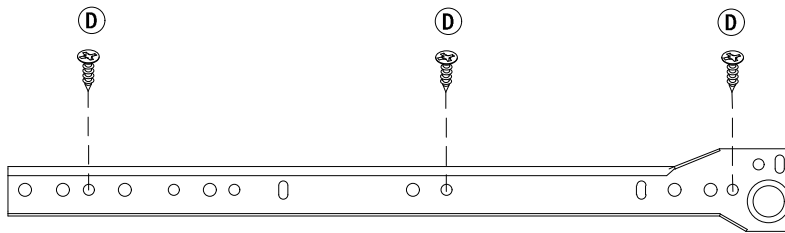

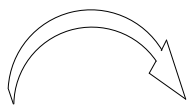
  
Turn Over

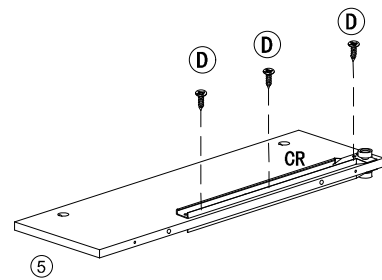

**X 2PCS**

# 2

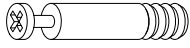

(B) 16 pcs

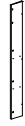

(8) 1 pc



(9) 1 pc

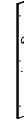

(19) 1 pc



(20) 1 pc

## Cam Lock Placement Supplement

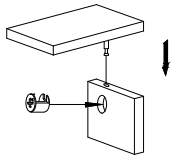

1

When inserting the Cam lock, make sure that the open End of the cam Lock faces the Cam Screw Entry.

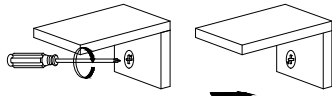



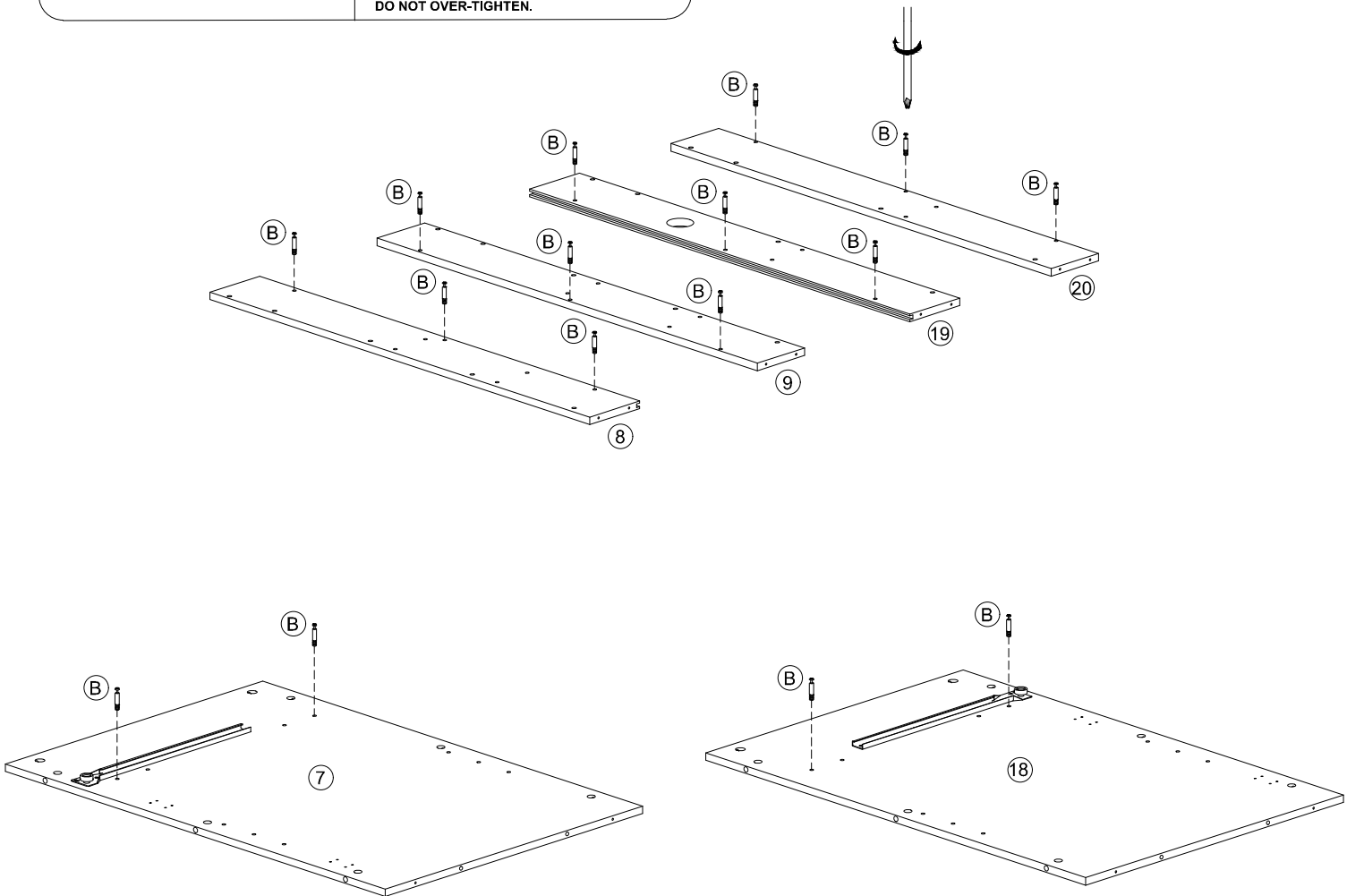

2  
To tighten, turn the Cam Lock CLOCKWISE until the arrow or "△" signs point AWAY from the connected Panel.

\*NOTE: DO NOT USE AN AUTOMATIC SCREWDRIVER TO TIGHTEN CAM LOCKS, DO NOT OVER-TIGHTEN.

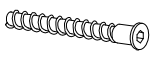

# 3

- A** 6 pcs 
- C** 4 pcs 
- E** 8 pcs 
- F** 8 pcs 
- I** 

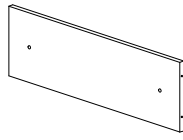
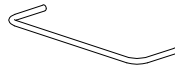
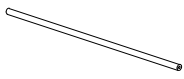
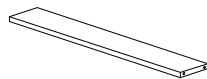
- 10** 1 pc 
- 11** 1 pc 
- 12** 3 pcs 
- 13** 2 pcs 

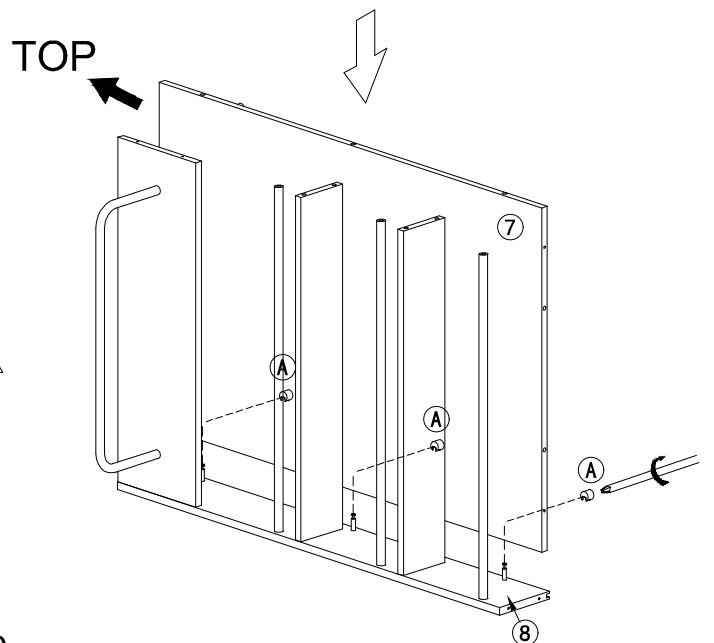
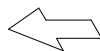
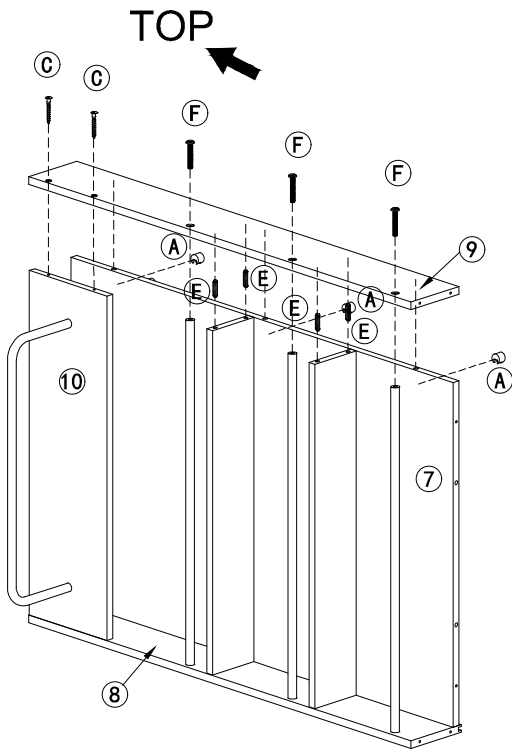
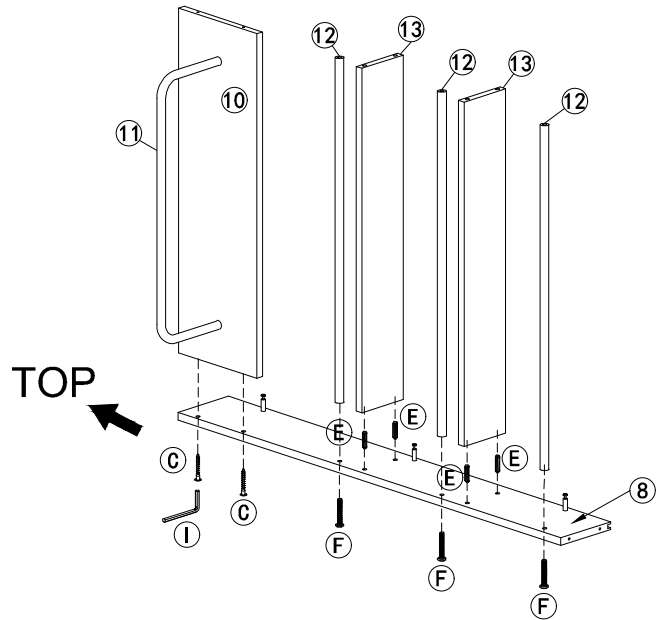
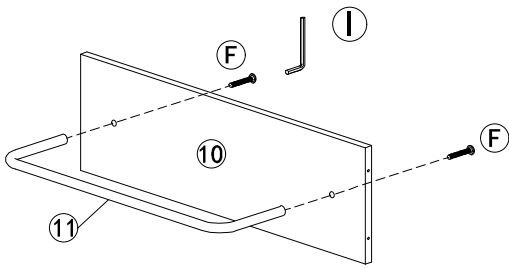

# 4

- A** 6 pcs
- C** 4 pcs
- E** 4 pcs
- F** 6 pcs
- I**

- 11** 1 pc
- 12** 2 pcs
- 13** 1 pc
- 21** 1 pc

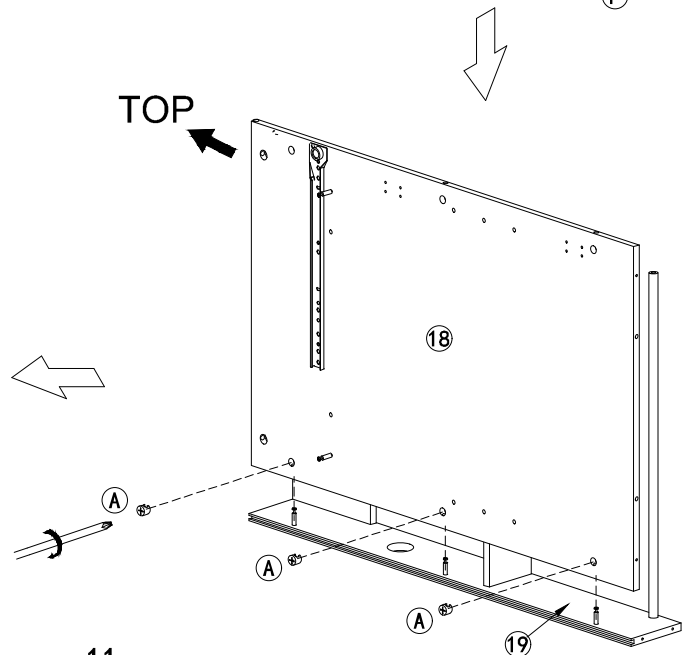
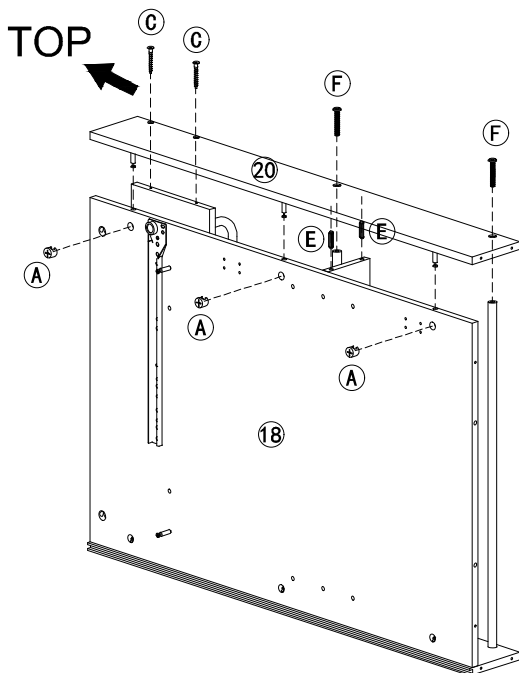
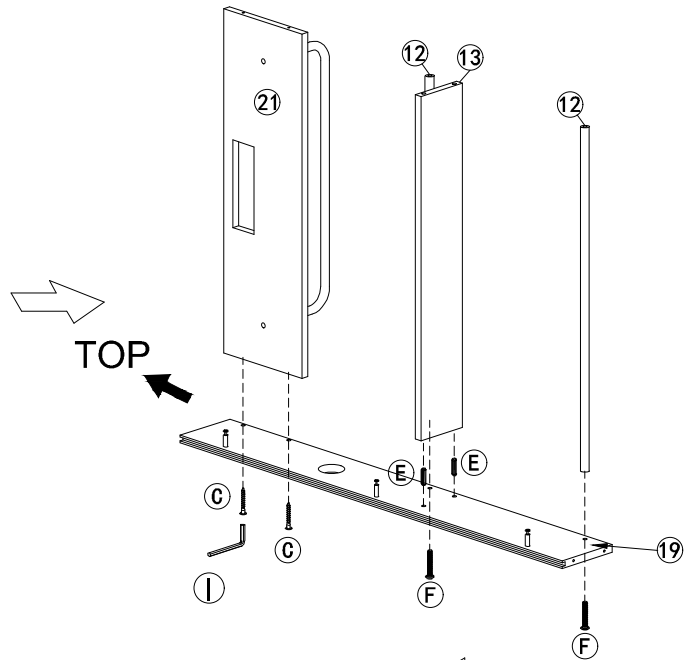
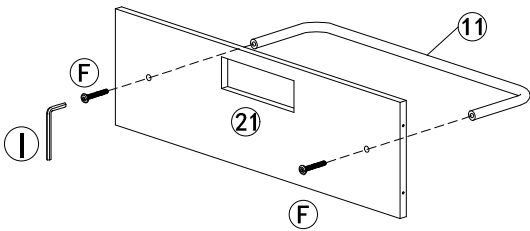

# 5

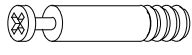

**B** 4 pcs



**C** 4 pcs



**E** 4 pcs



**I**

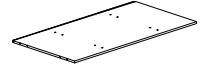

**6** 1 pc

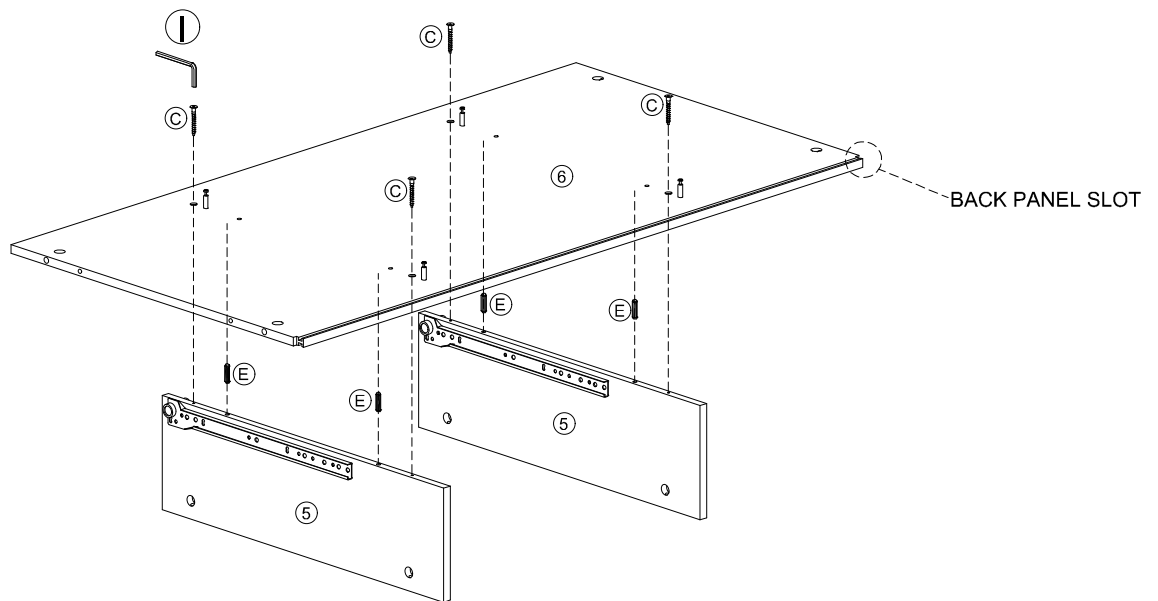
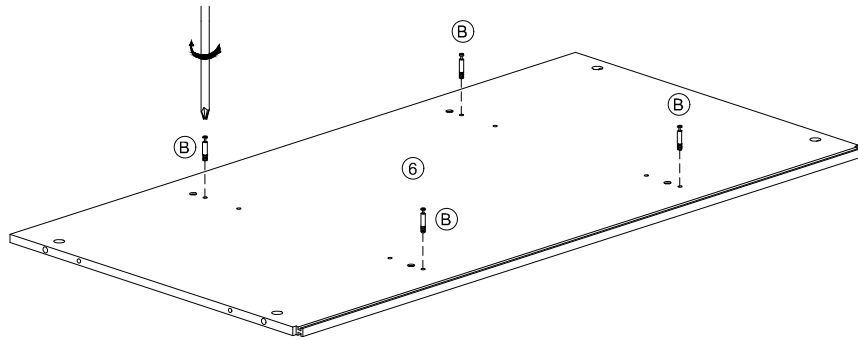

# 6

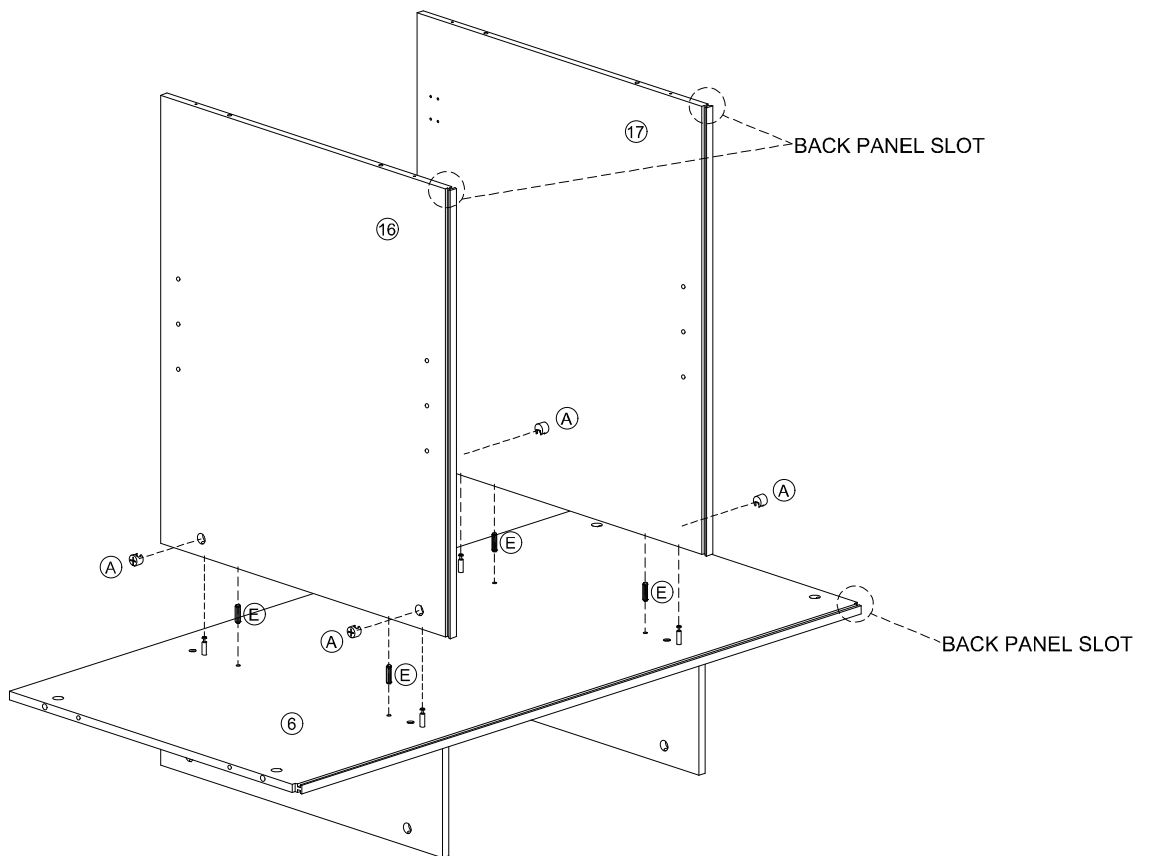
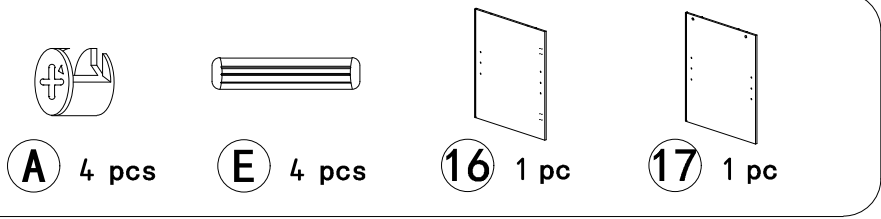

# 7



**A** 4 pcs



**E** 12 pcs

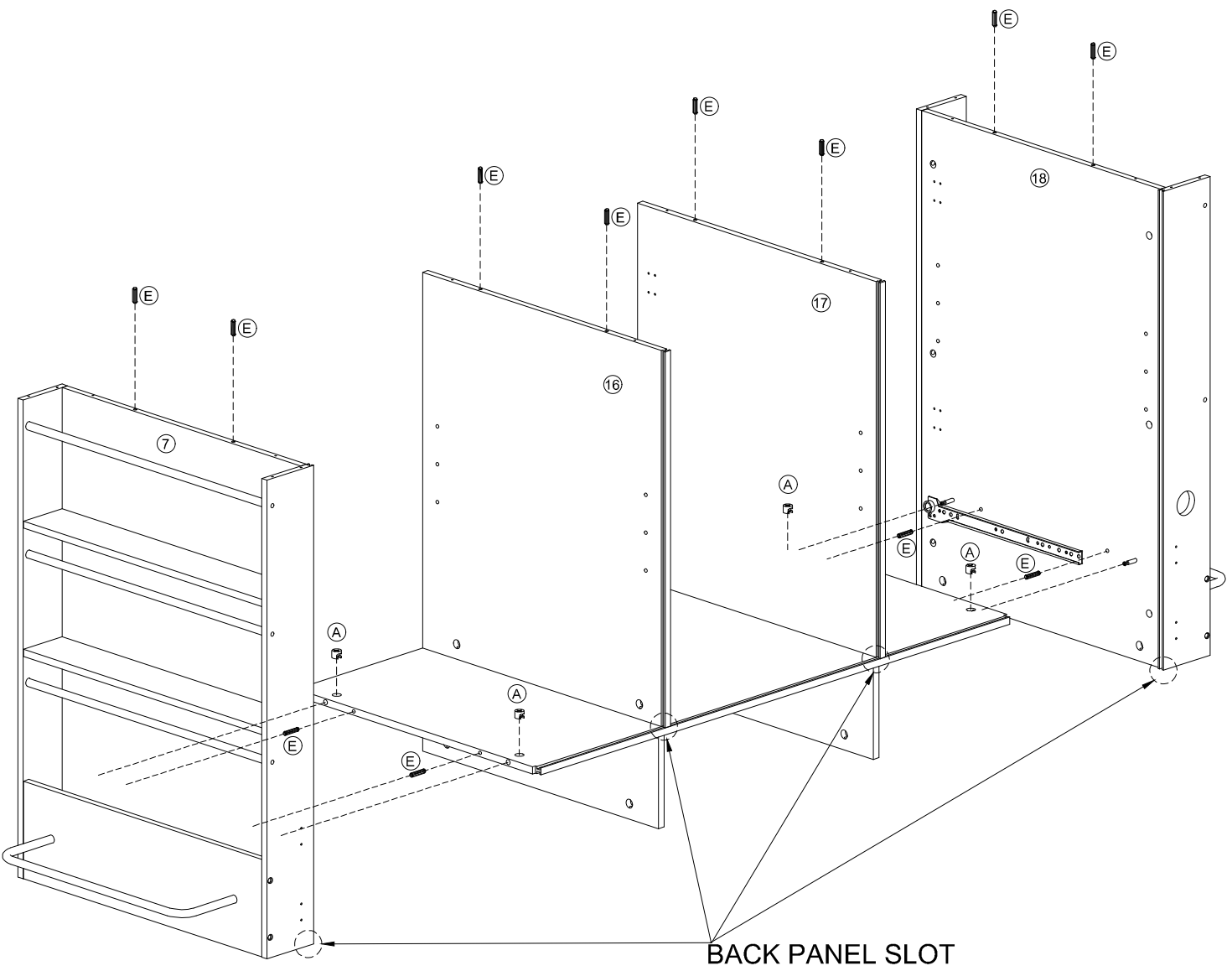

8

37 2 pcs

38 1 pc

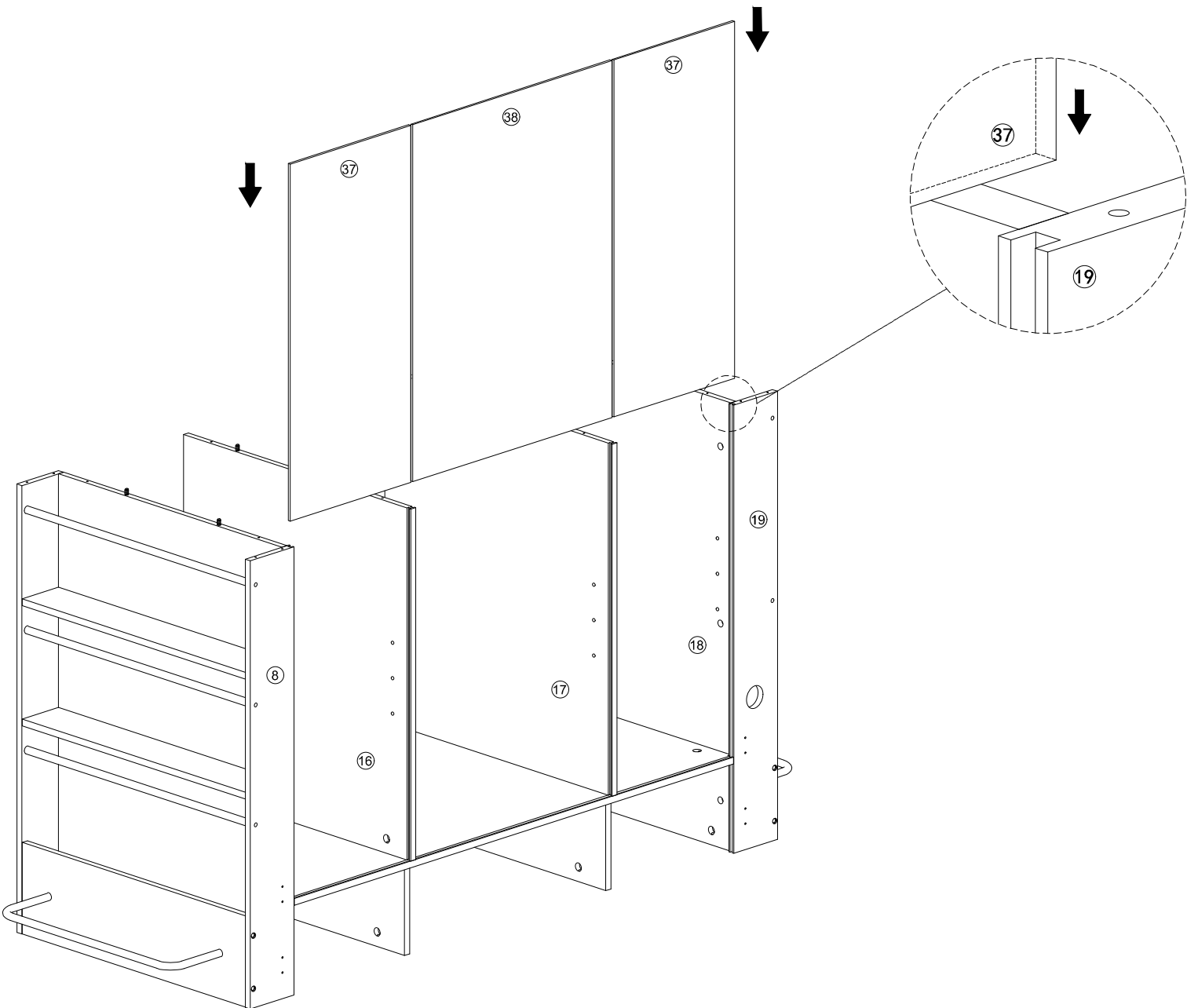

# ASSEMBLY INSTRUCTIONS

# 9

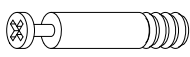

**B** 10 pcs



**C** 16 pcs



**I**



**22** 1 pc

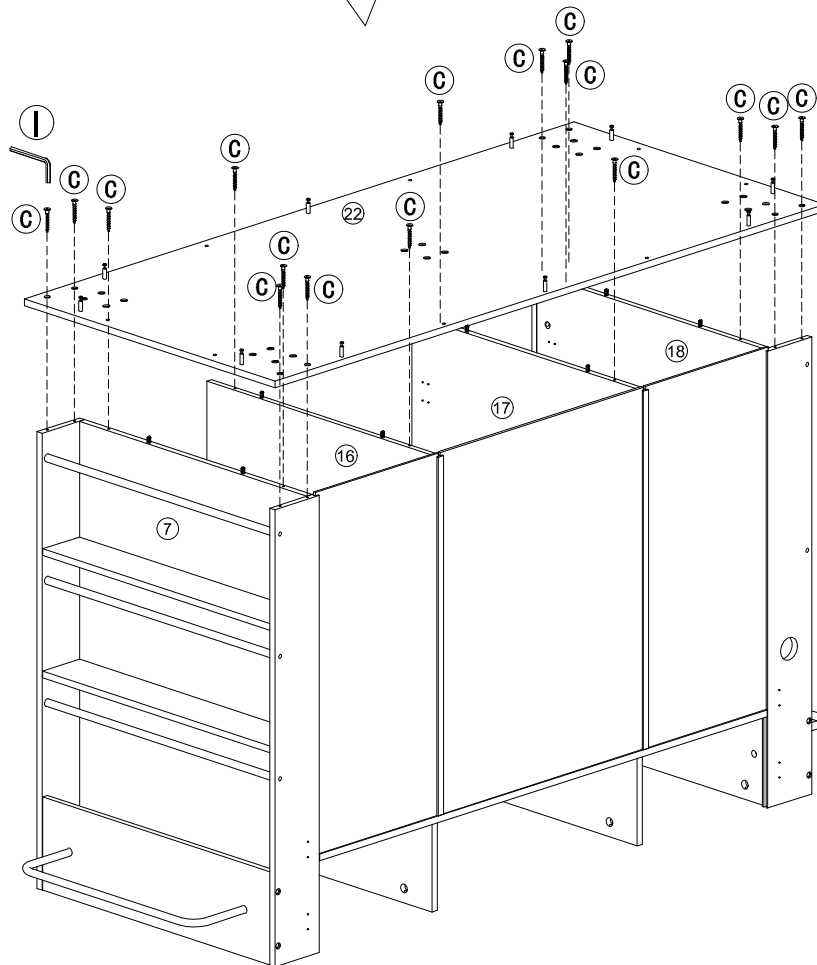
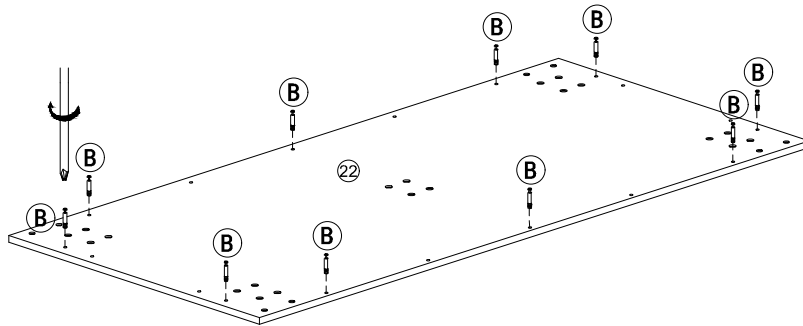

# 10

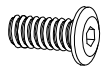

**G** 20 pcs



**I**

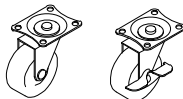

**M** 5 pcs

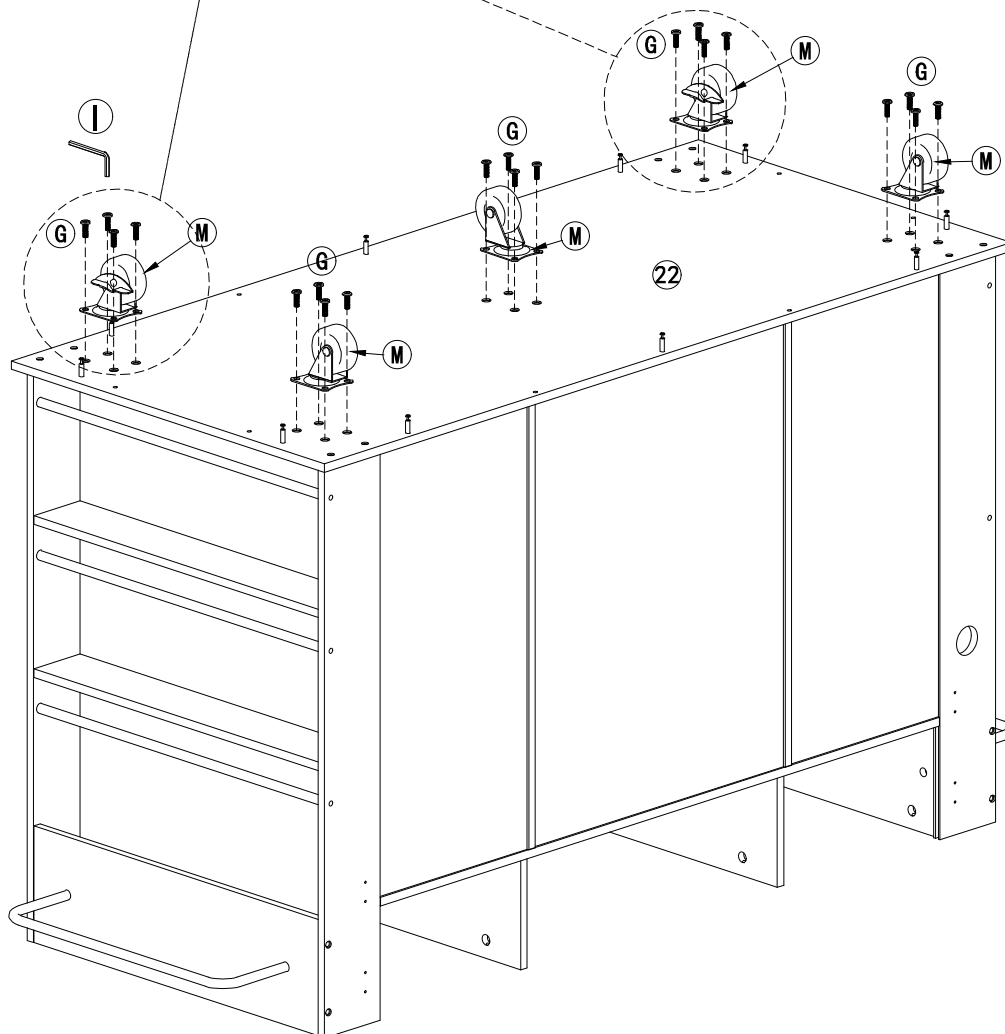
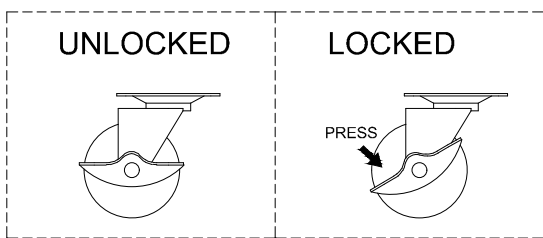

# 11



A 10 pcs



E 8 pcs

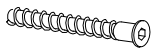

C 8 pcs



I



23 2 pcs



24 2 pcs

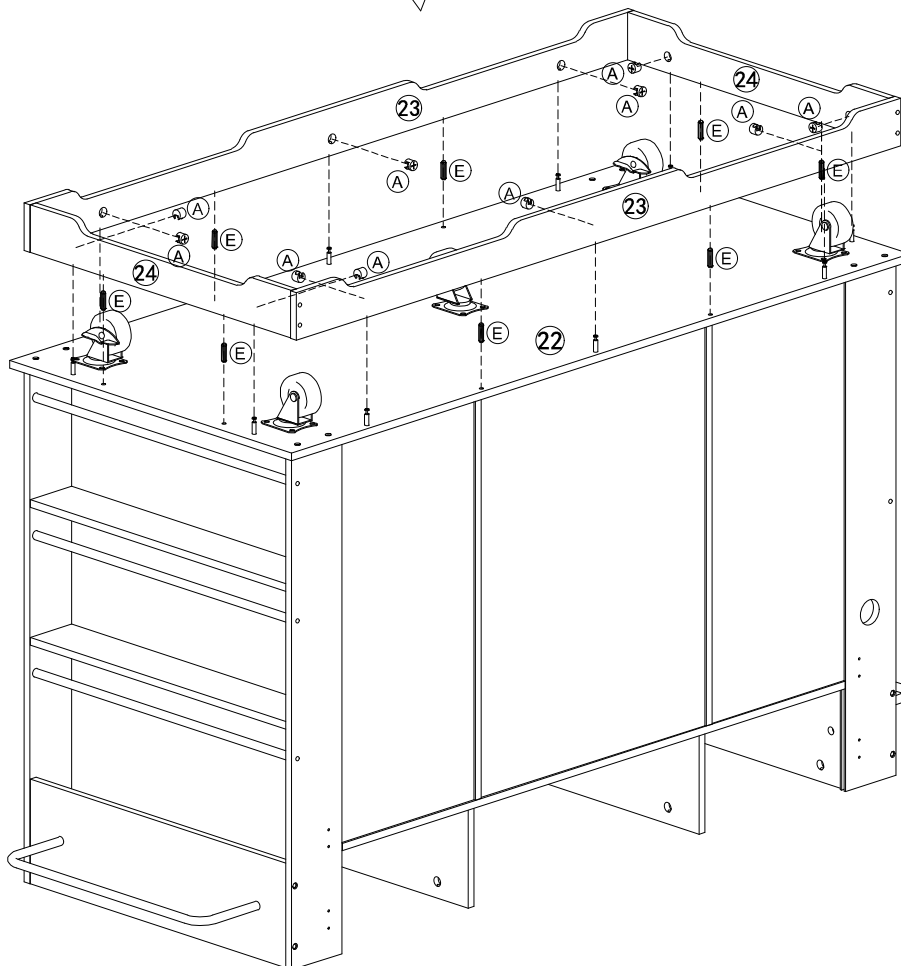
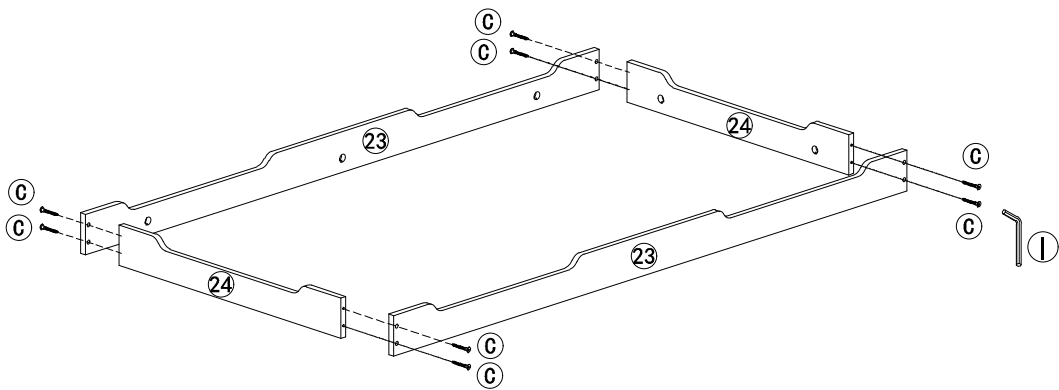

# 12

 **D** 2 pcs

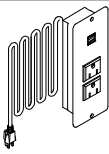
 **P** 1 pc

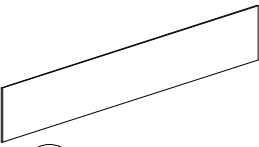
 **36** 1 pc

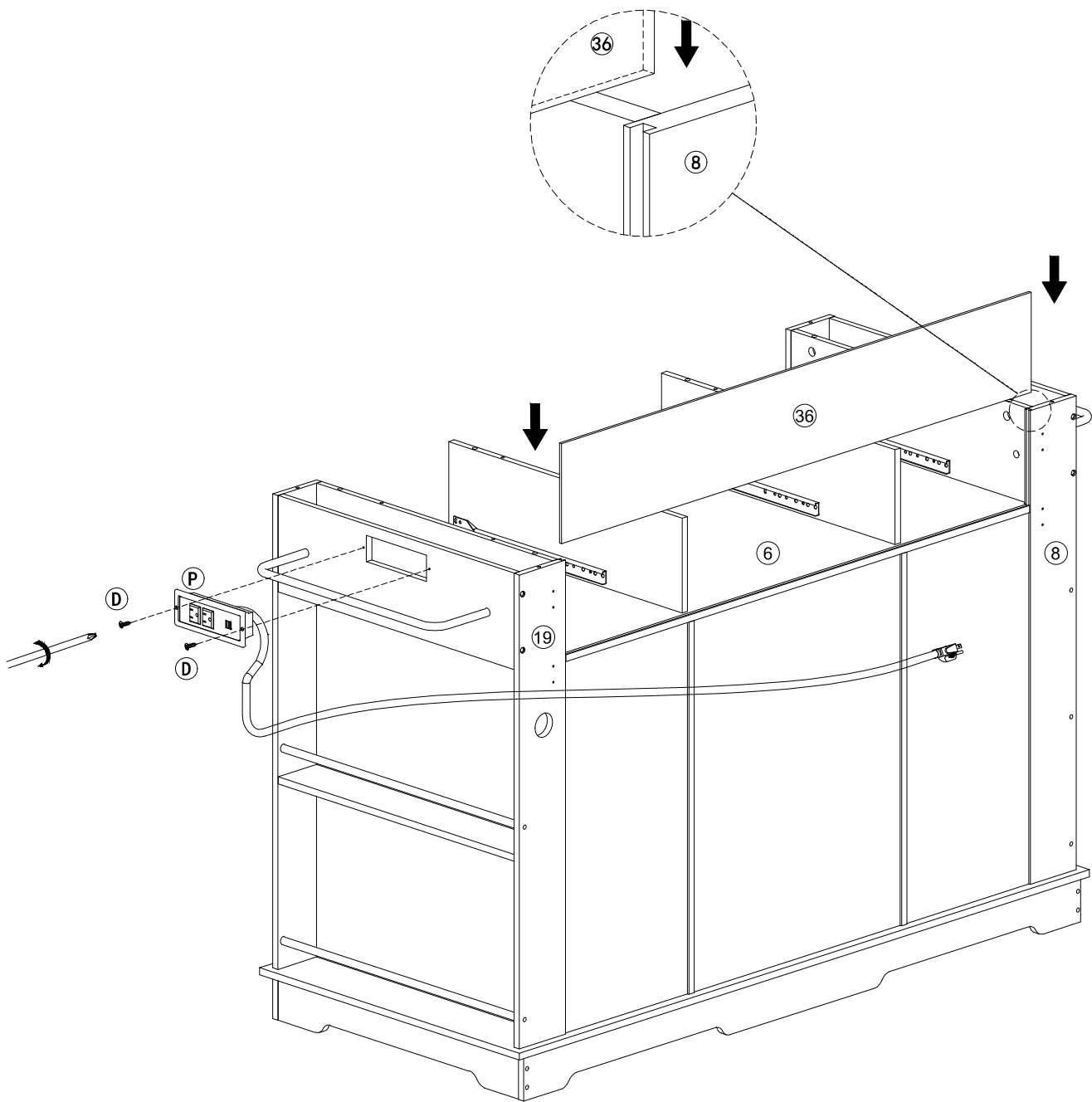

# 13

**D** 16 pcs

**K** 4 pcs

**1** 1 pc

**2** 1 pc

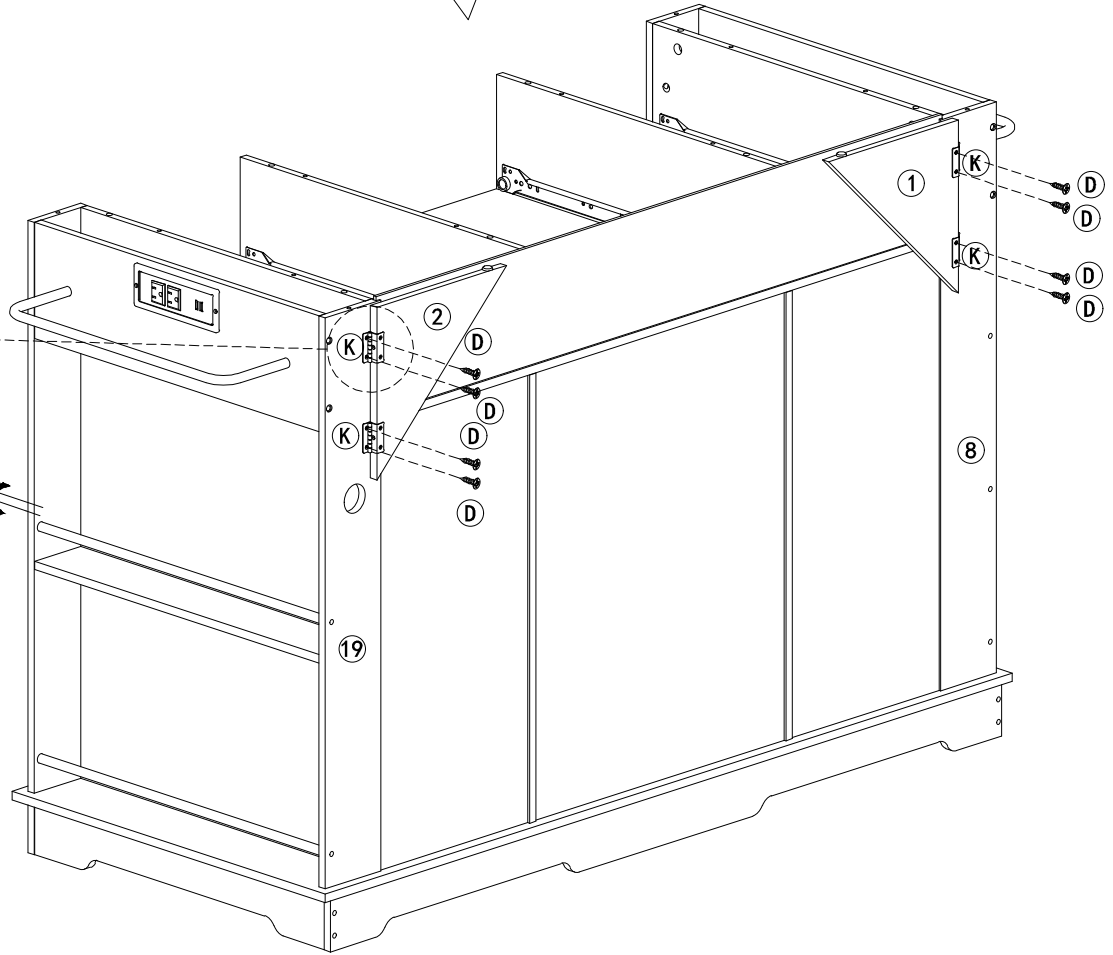
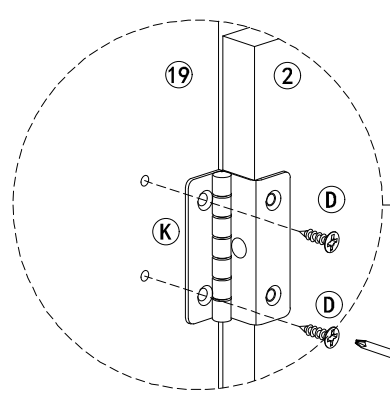
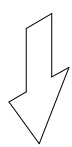
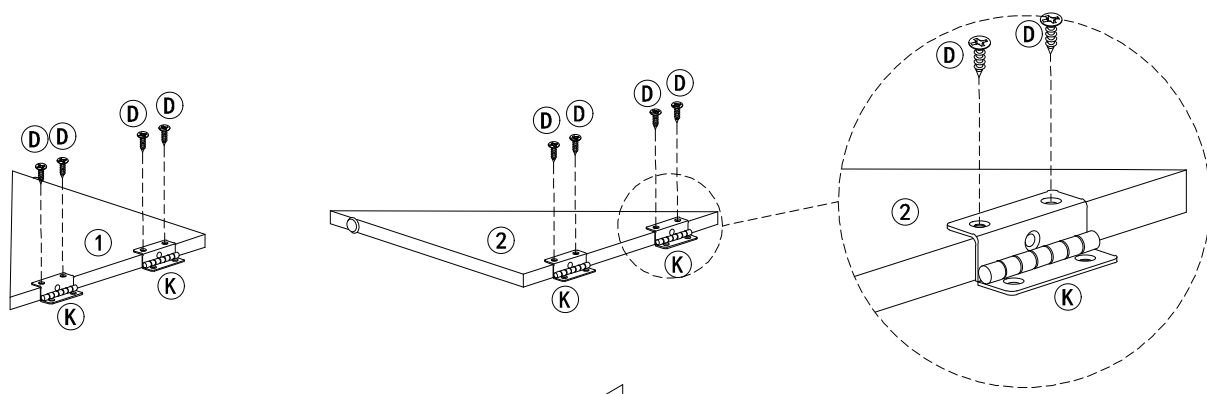

# 14

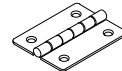

**A** 8 pcs

**B** 8 pcs

**D** 12 pcs

**E** 10 pcs

**L** 3 pcs

**3** 1 pc

**4** 1 pc

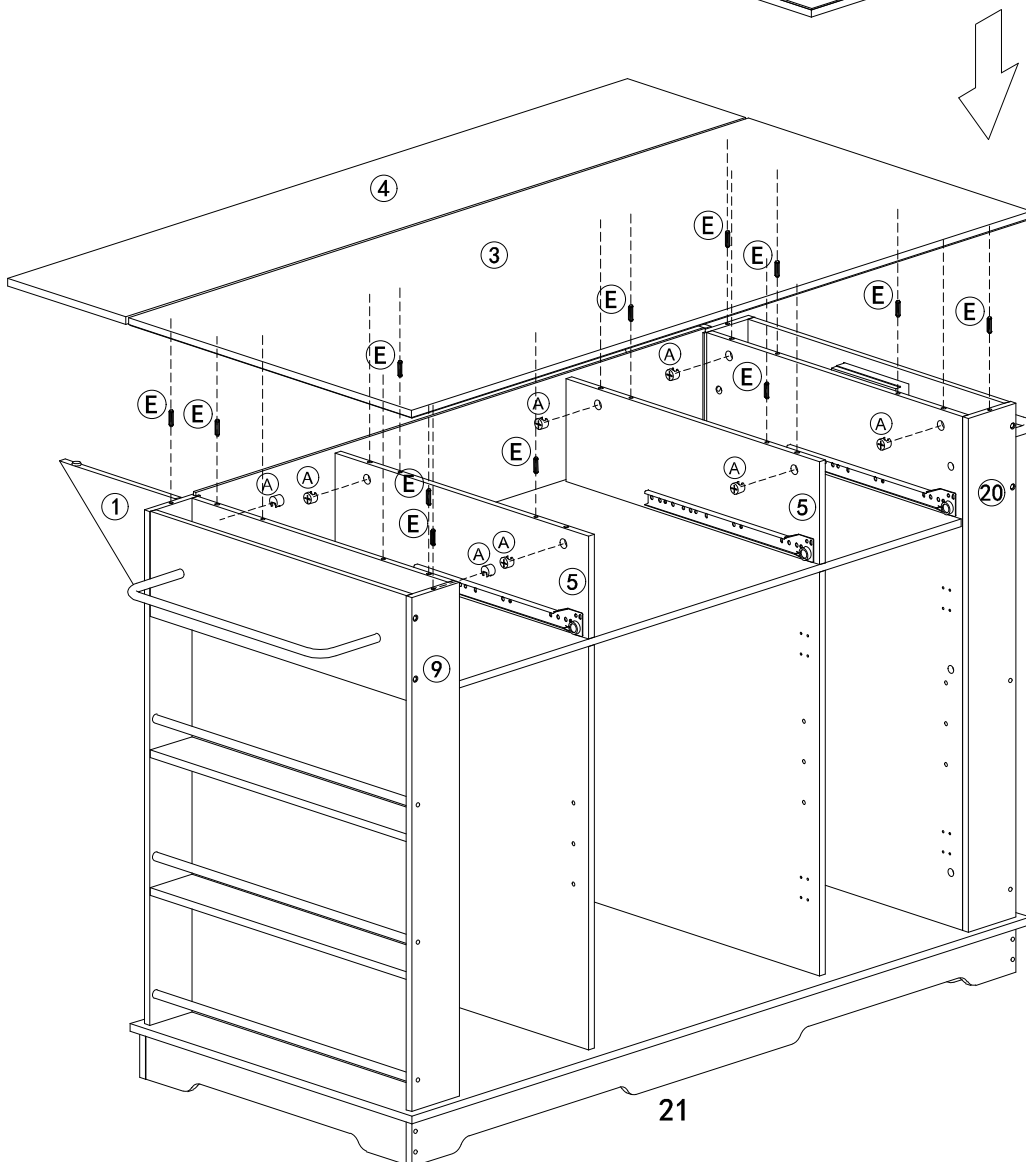
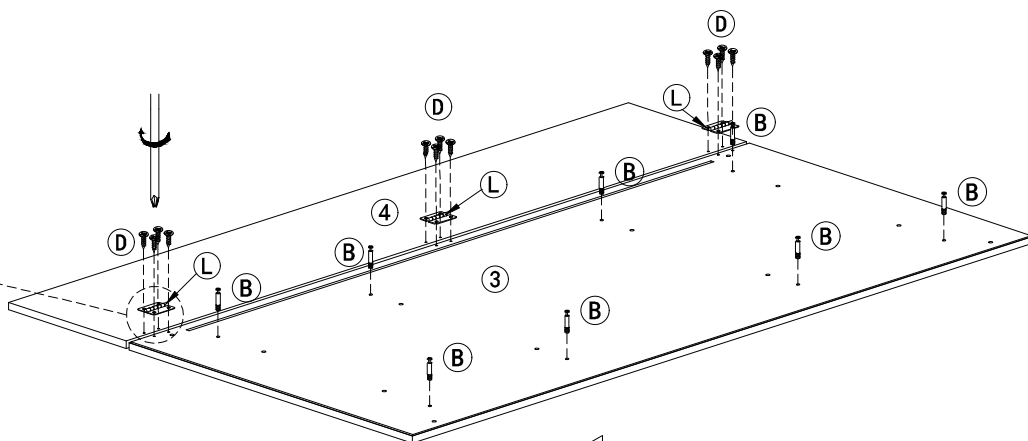
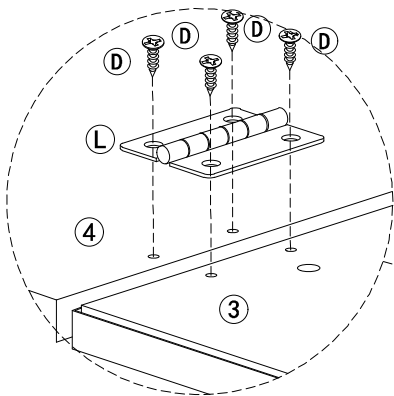

# 15

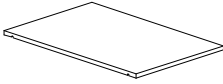
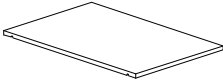
-  **J** 12 pcs
-  **14** 2 pcs
-  **15** 1 pc

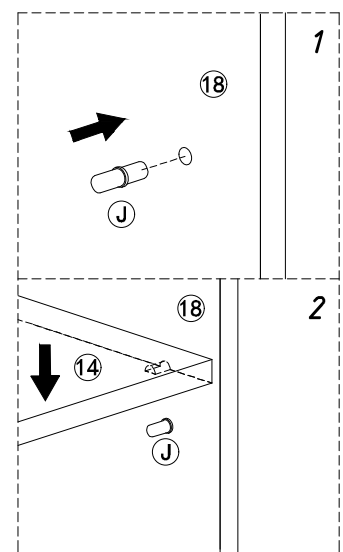
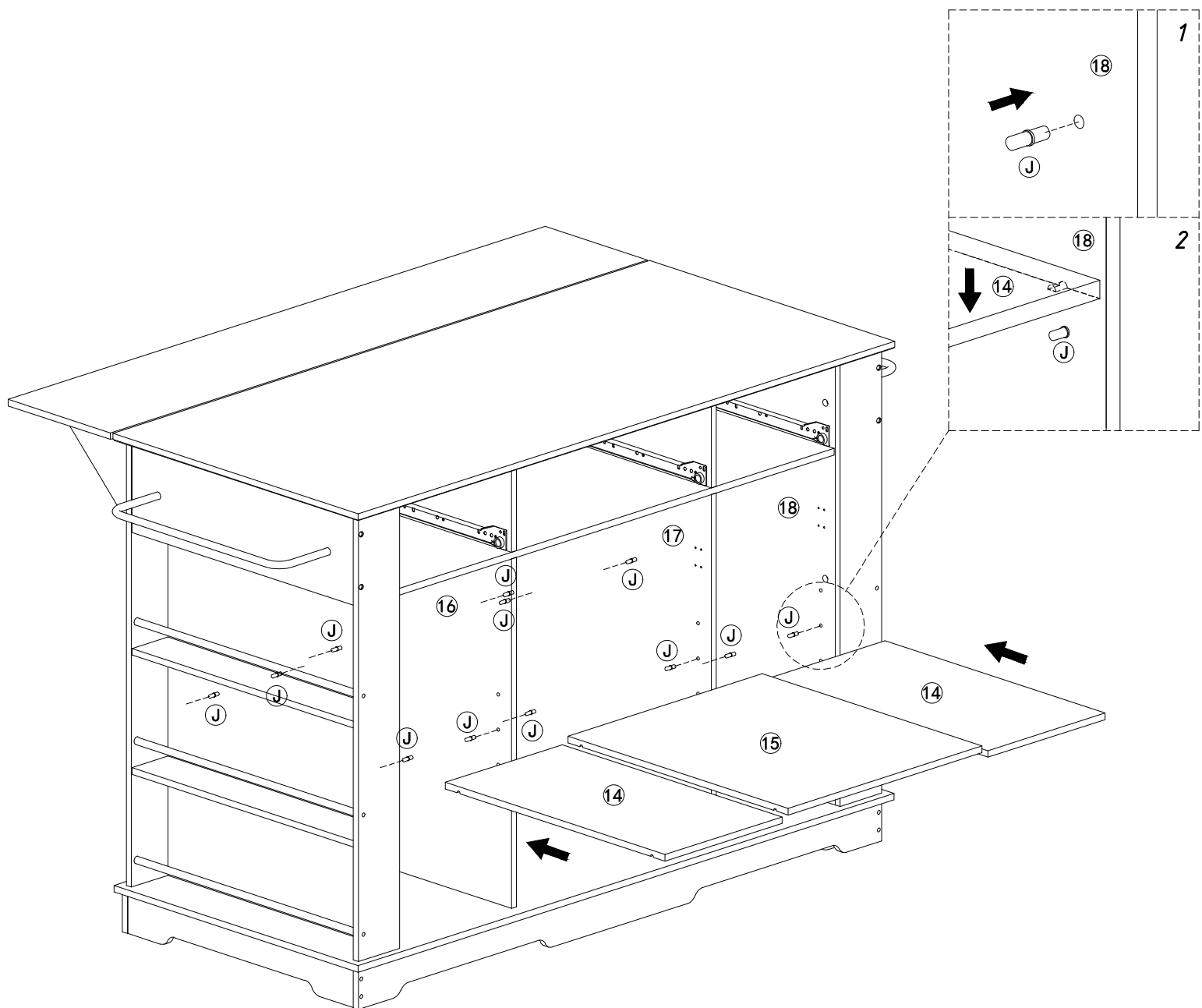

# 16

- D** 48 pcs
- H** 4 pcs
- N** 8 pcs
- O** 4 pcs
- 25** 2 pcs
- 26** 2 pcs

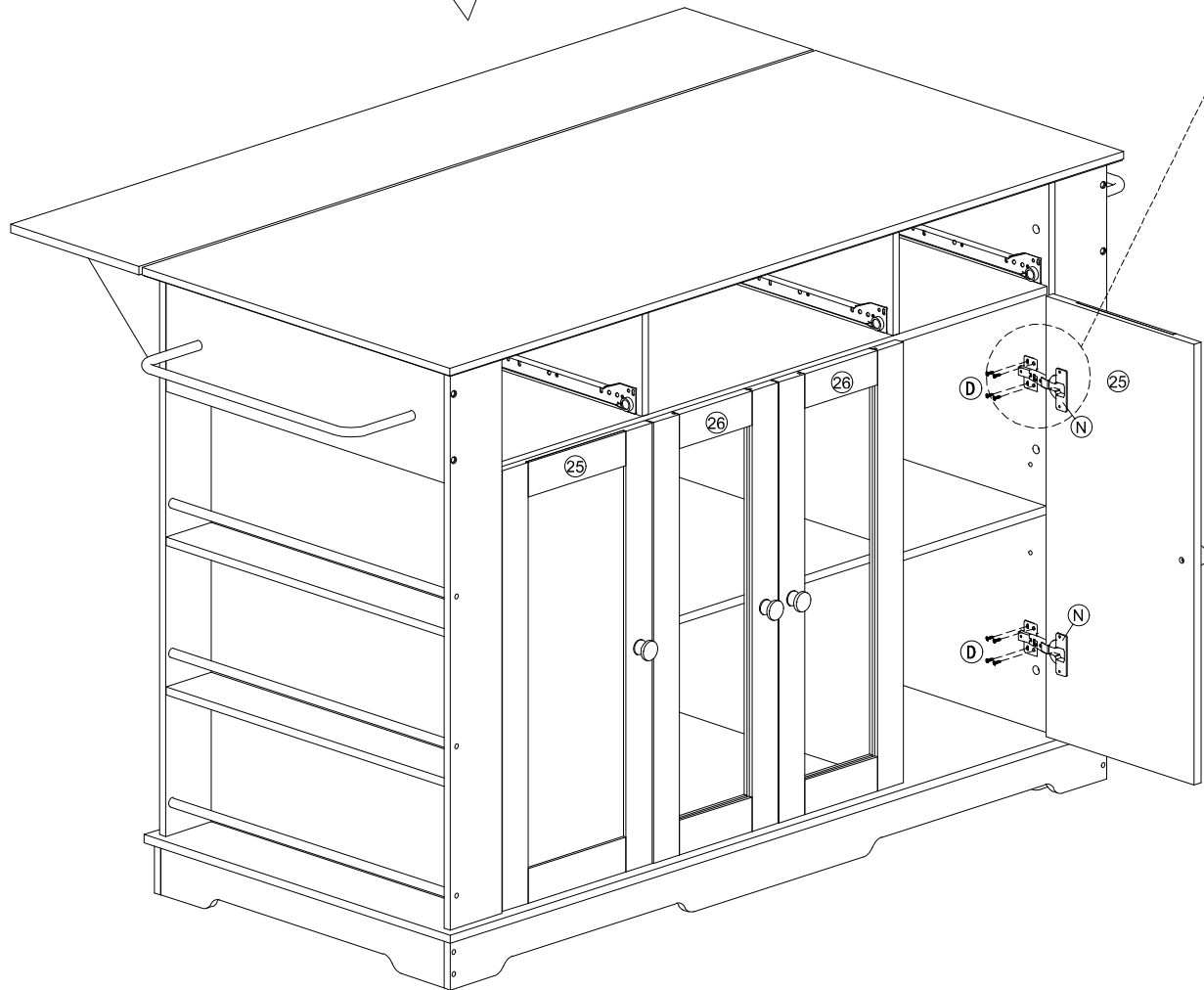
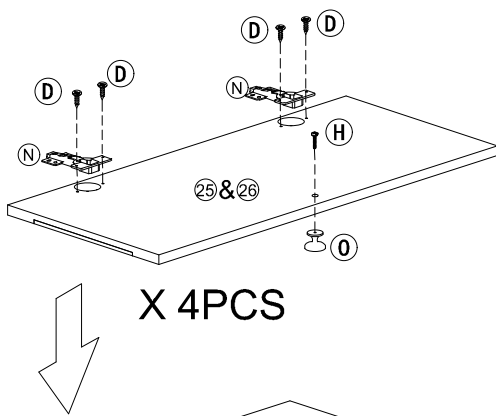

Please refer to hinge adjustment supplement next page

# ASSEMBLY INSTRUCTIONS

## HINGE ADJUSTMENT SUPPLEMENT

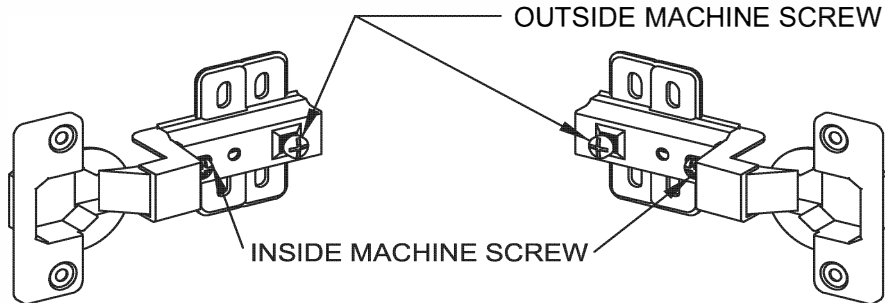

In the event that the door does not align properly, the INSIDE Machine Screws located on the Hinges are for adjusting slightly to the Left or Right. **DO NOT LOOSEN THE OUTSIDE MACHINE SCREW FOR ADJUSTMENT.**

A. To adjust the door toward the OUTSIDE of the unit, turn the Inside Machine Screws to the LEFT, or COUNTERCLOCKWISE. (See Figure A)

B. To adjust the door toward the INSIDE of the unit, turn the Inside Machine Screws to the RIGHT, or CLOCKWISE. (See Figure B)

**\*Note: Please be patient, it may take several minutes to adjust properly.**

Only once the door is in the desired position, fully tighten the OUTSIDE Machine Screws. This will ensure that the door is secure.

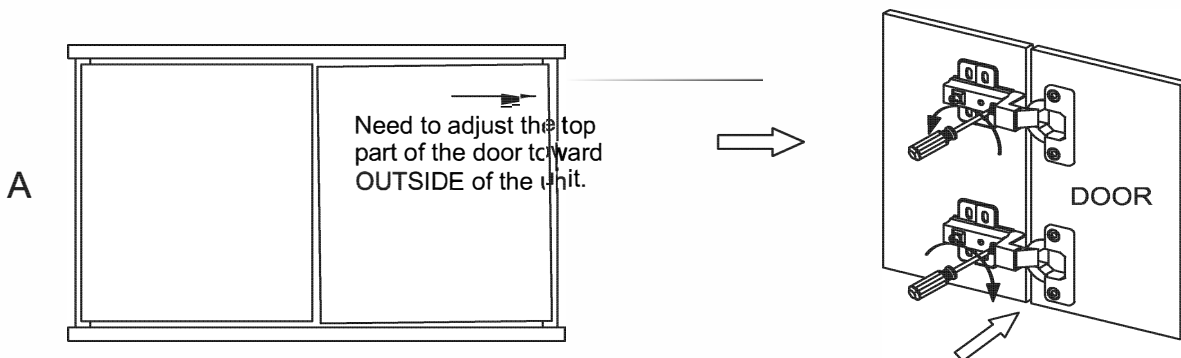

You may also need to adjust slightly the lower part of the door toward INSIDE of the unit at the same time.

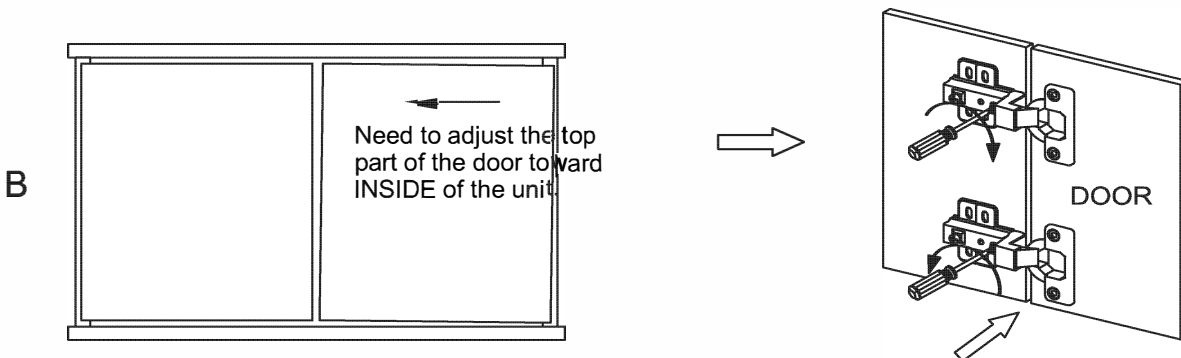

You may also need to adjust slightly the lower part of the door toward OUTSIDE of the unit at the same time.

# 17

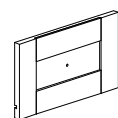
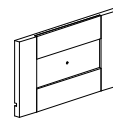
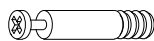

**A** 8 pcs

**B** 8 pcs

**C** 8 pcs

**H** 2 pcs

**I**

**O** 2 pcs

**27** 1 pc

**29** 1 pc

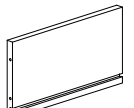
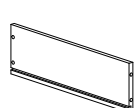
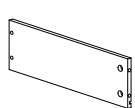

**30** 2 pcs

**31** 2 pcs

**32** 2 pcs

**33** 2 pcs

## X 2PCS

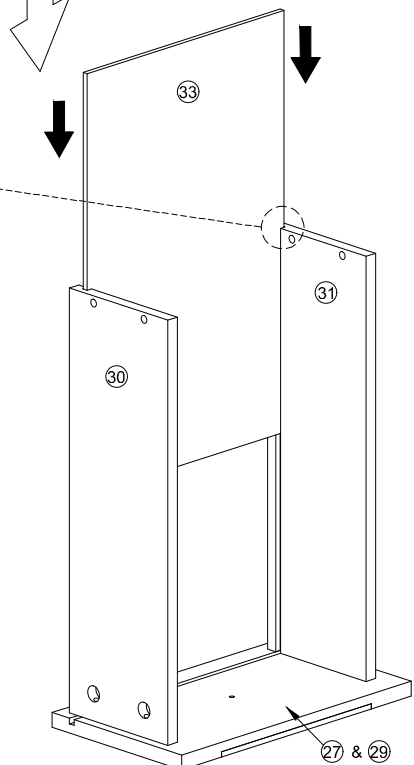
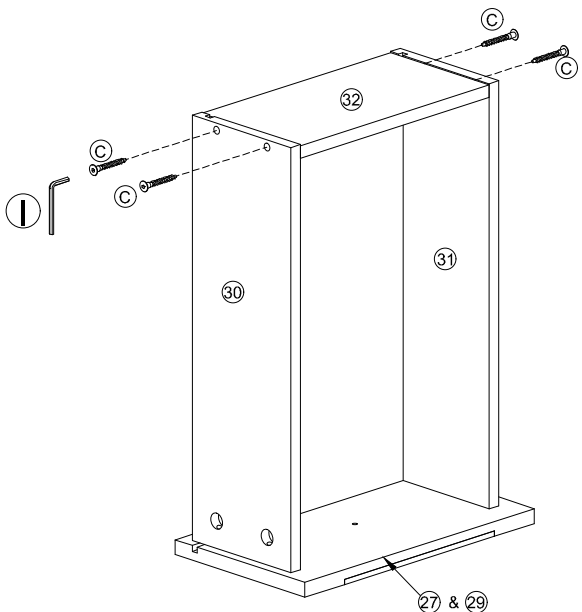
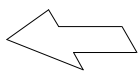
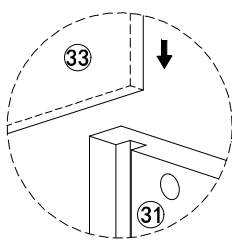
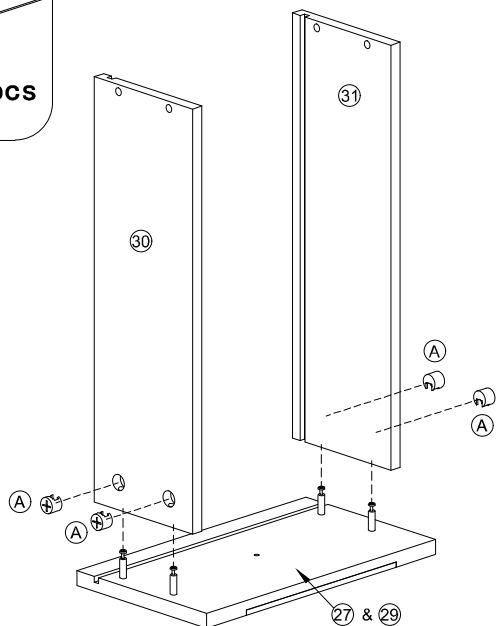
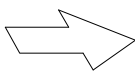
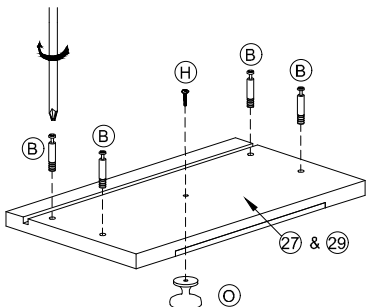

# 18



**A** 4 pcs

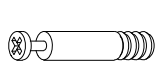

**B** 4 pcs



**C** 4 pcs



**H** 1 pc



**I**



**O** 1 pc

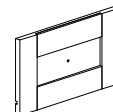

**28** 1 pc

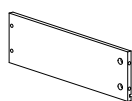

**30** 1 pc



**31** 1 pc

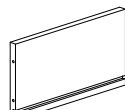

**34** 1 pc



**35** 1 pc

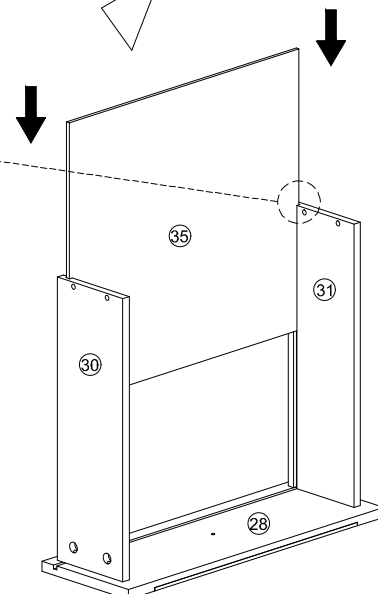
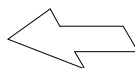
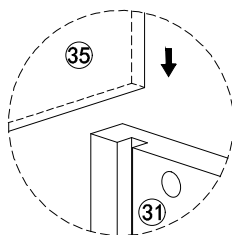
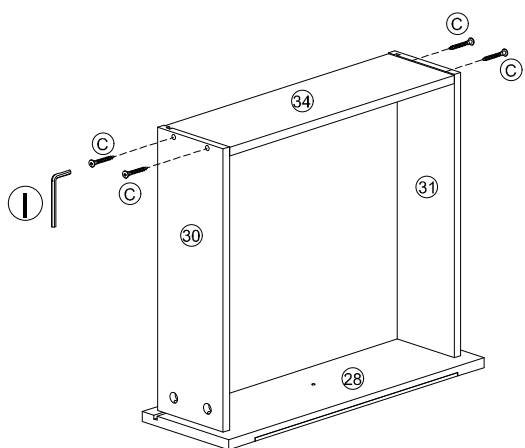
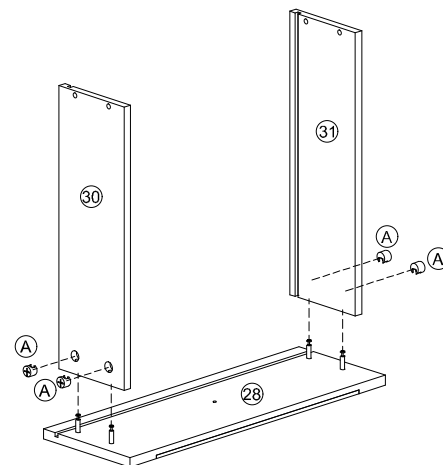
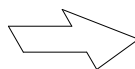
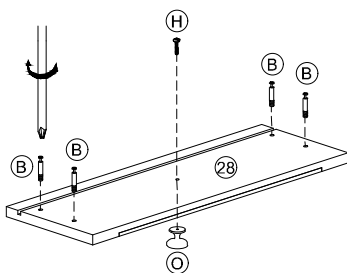

# 19

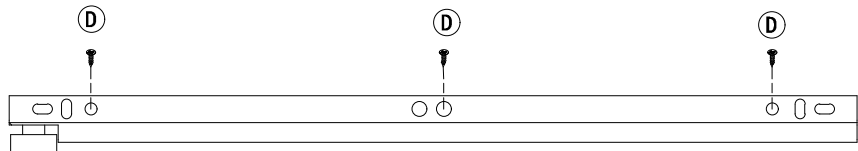
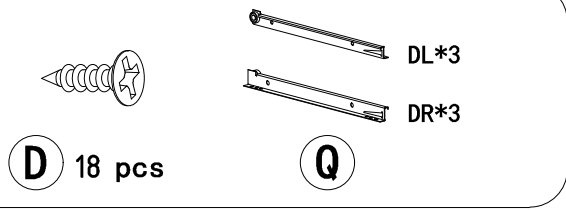

**X 3PCS**

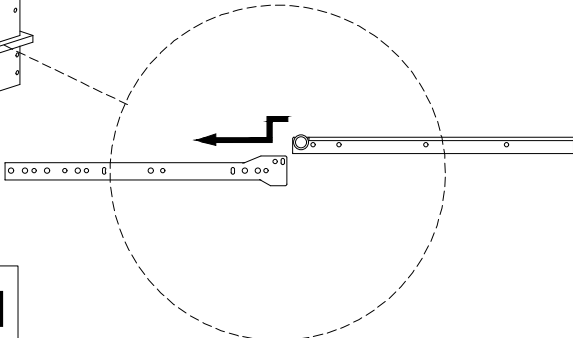
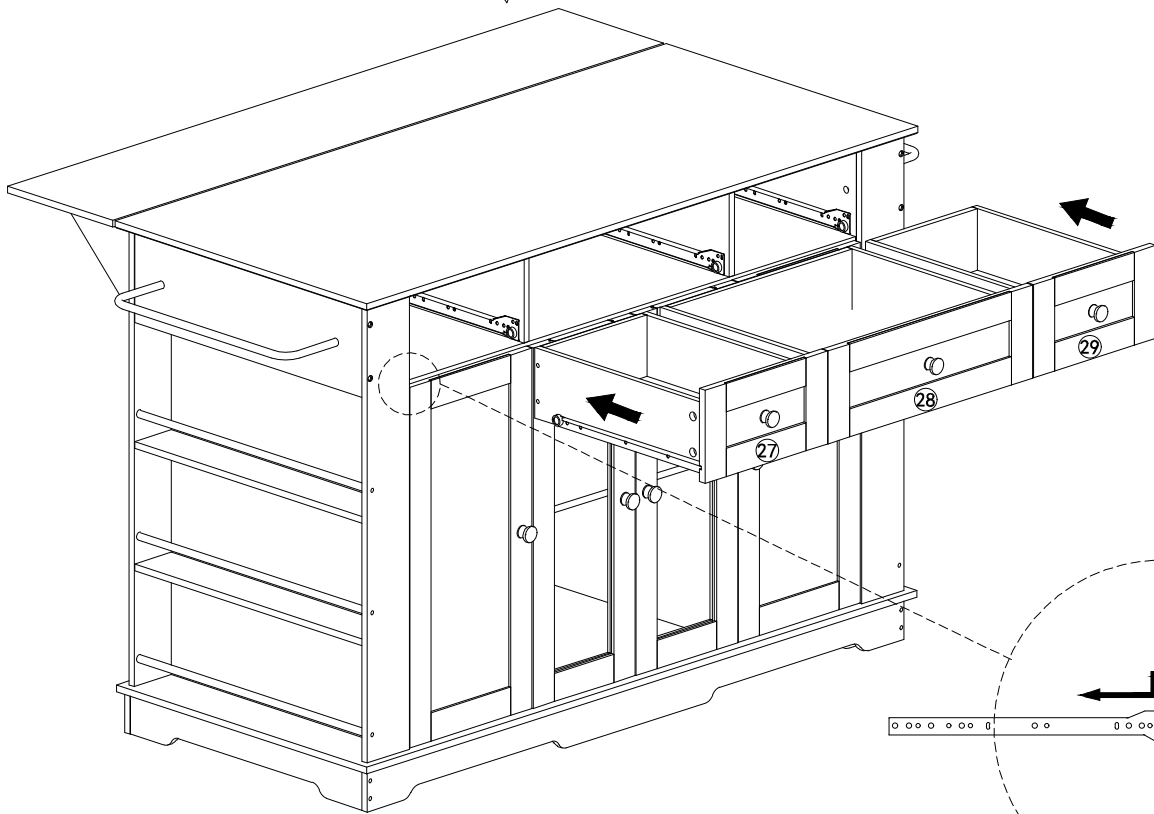
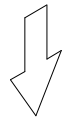
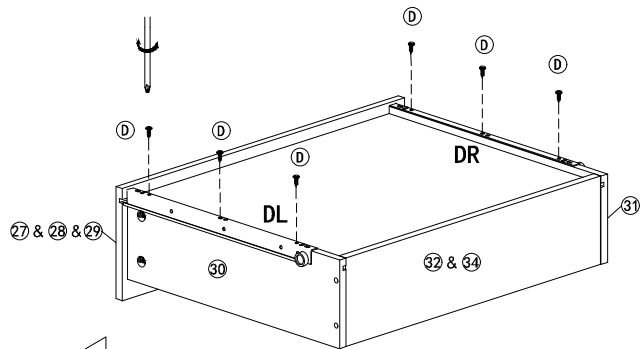

**Installation Completed**