

9 GRID BOOKSHELF

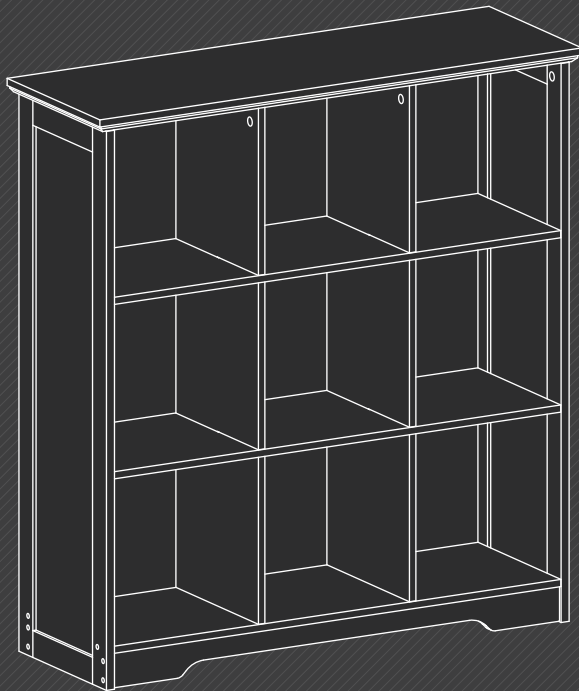

USER MANUAL



Contents

TOPIC

PAGE

01	SAFETY INSTRUCTIONS	01-01
	1-1 Thank You For Choosing Our Product	01
	1-2 Precautions	01

02	INSTALLING MODULES	02-16
	2-1 Disassembly Diagram	02
	2-2 Parts List	03
	2-3 Assembly Instructions	04-16

03	CUSTOMER SERVICE	17
	3-1 30-Day Return Policy	17
	3-2 1-Year Warranty	17
	3-3 Quick Response Within 24 Hours	17

04	PROBLEMS YOU MAY ENCOUNTER	18
	4-1 Problems You May Encounter	18

Safety Instructions

Thank You For Choosing Our Product

Before assembly, please read this USER MANUAL first, and check according to Parts List to make sure all parts are included. Feel free to contact us if you have any concerns or questions about your product, we are always ready to help. Your satisfaction is our first priority!

Precautions

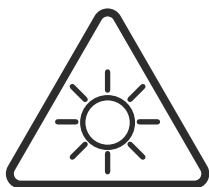

- Avoid long-term direct sunlight exposure.



- Keep away from sharp objects.

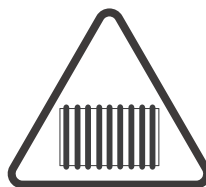

- Keep away from heat.



- Keep infants/children away from assembly parts to avoid choking and suffocation.



- Keep away from corrosive substances.



- Pay attention to avoid over-tightening fasteners, or they may induce cracking within the board.

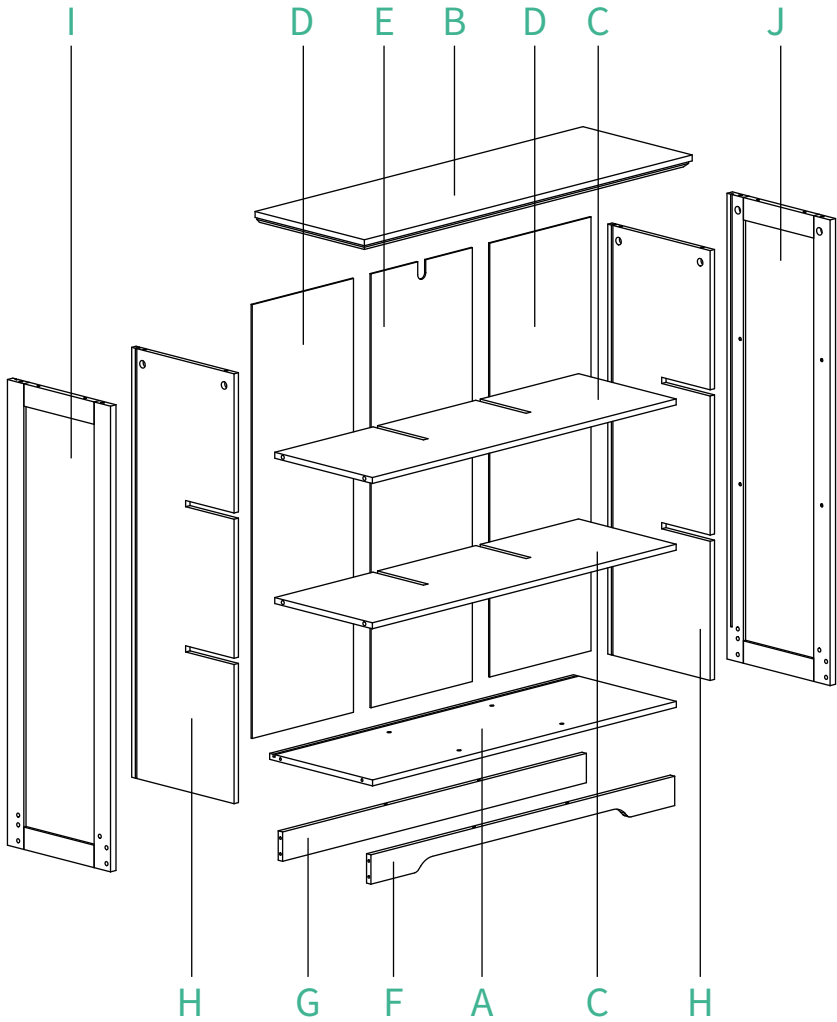

Disassembly Diagram

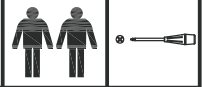

Parts List

For ease and safety, we recommend two people for assembly.

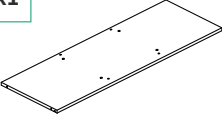
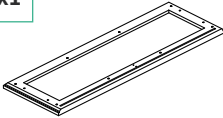
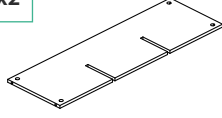
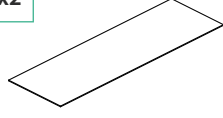
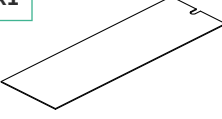
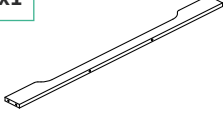
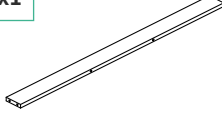
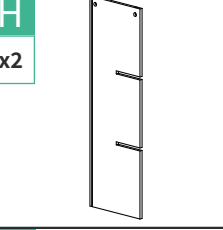
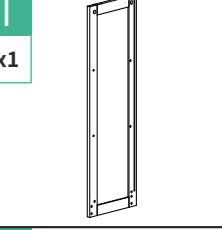
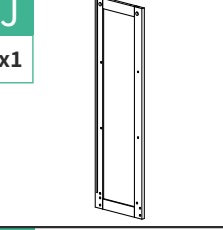
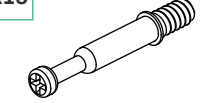
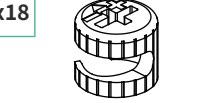

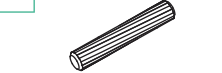
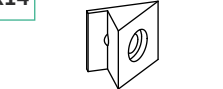
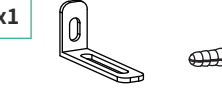
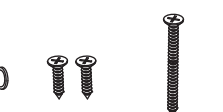
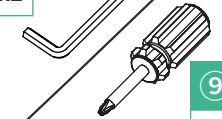
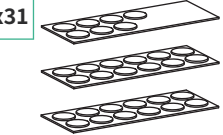
A x1 	B x1 	C x2 	D x2 
E x1 	F x1 	G x1 	H x2 
I x1 	J x1 	1 x18 	2 x18 
3 x18 	4 x14 	5 x9 	6 x14 
7 x1 	8 x2 	9 x1 	10 x31 

ST6x50

2 Spares

ST4x14

2 Spares

φ6x25

1 Spare

2 Spares

Assembly Instructions

N-1

Make sure the grooves indicated by the arrows are all on the same side.

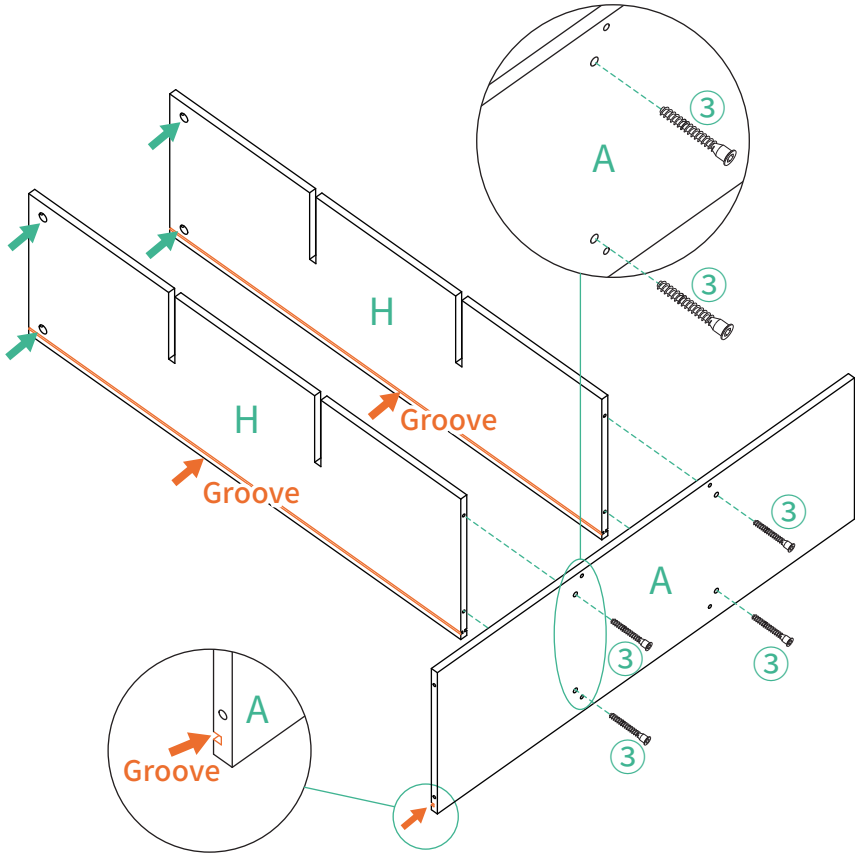

A x1		H x2		3 x4		8 x1	
----------------	--	----------------	--	----------------	--	----------------	--

Assembly Instructions

N-2

Make sure the holes indicated by the arrows on panel C are facing the correct direction during installation.

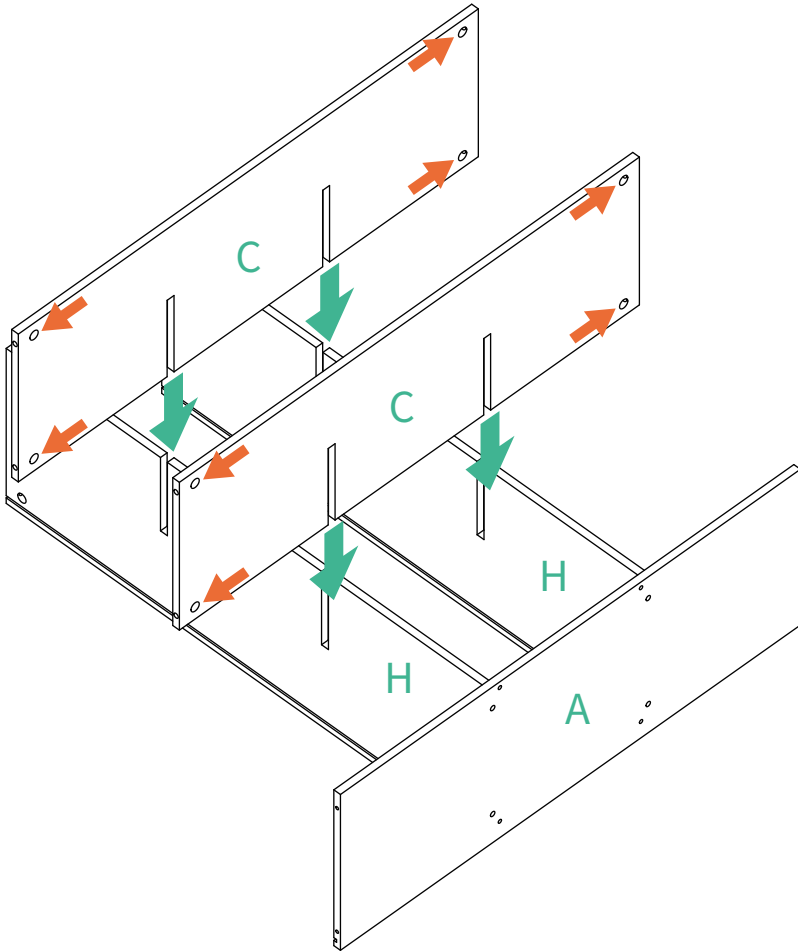
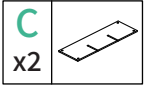

Assembly Instructions

N-3

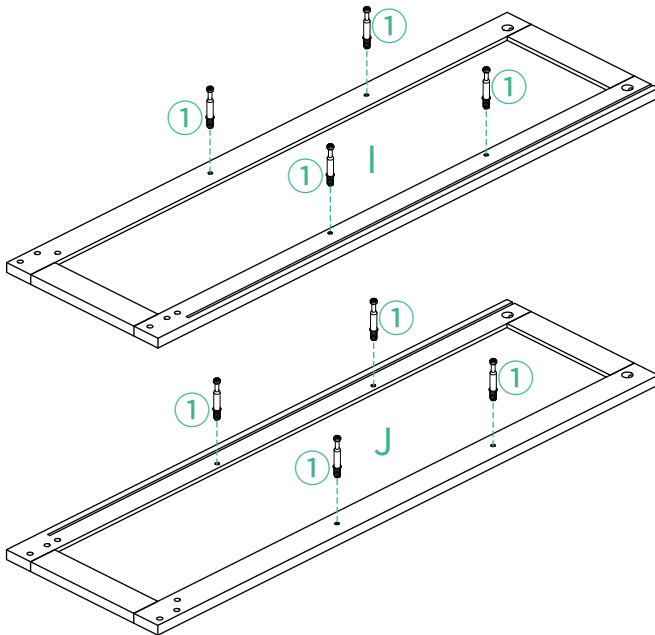
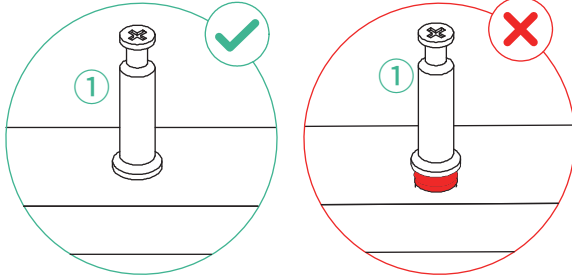

Assembly Instructions

N-4

Make sure the groove of the center Panel H is on the same side as Panel G, and that Panel F is installed on the opposite side of that grooved side.

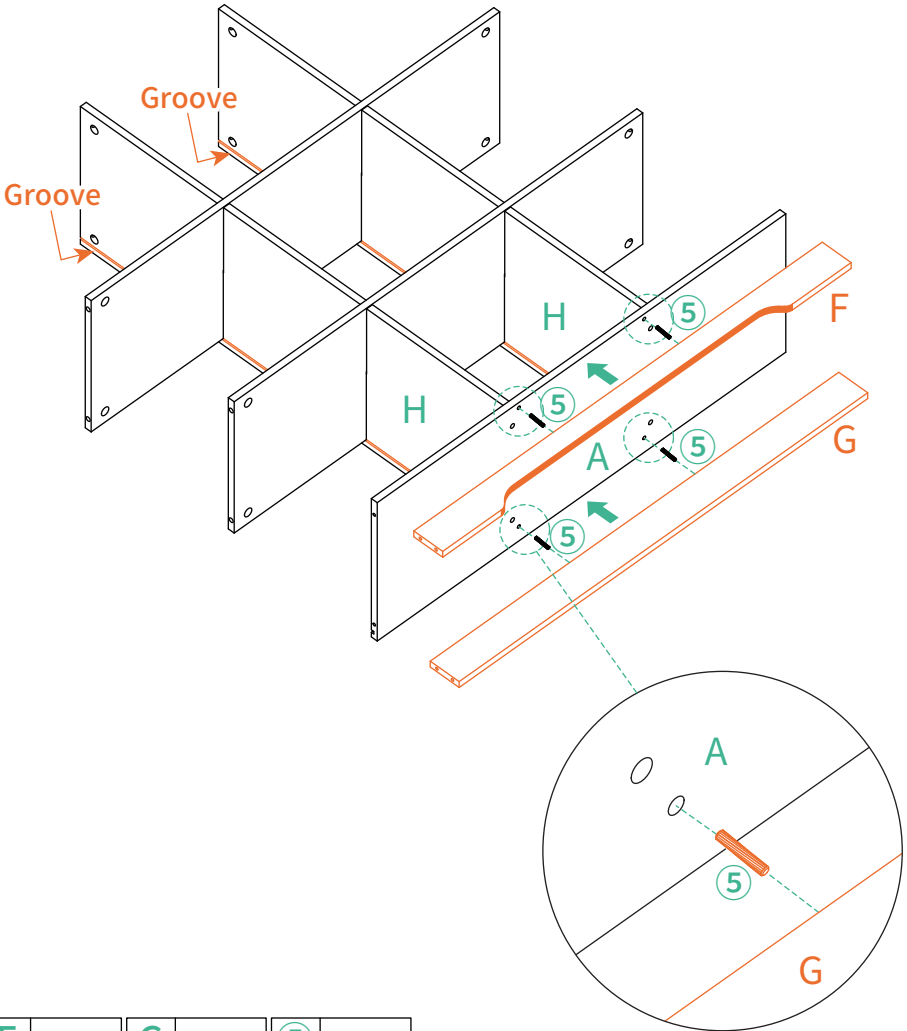

F x1		G x1		(5) x4	
----------------	---	----------------	---	------------------	---

Assembly Instructions

N-5

Make sure the hole indicated by the arrow on panel J is facing inward during installation.

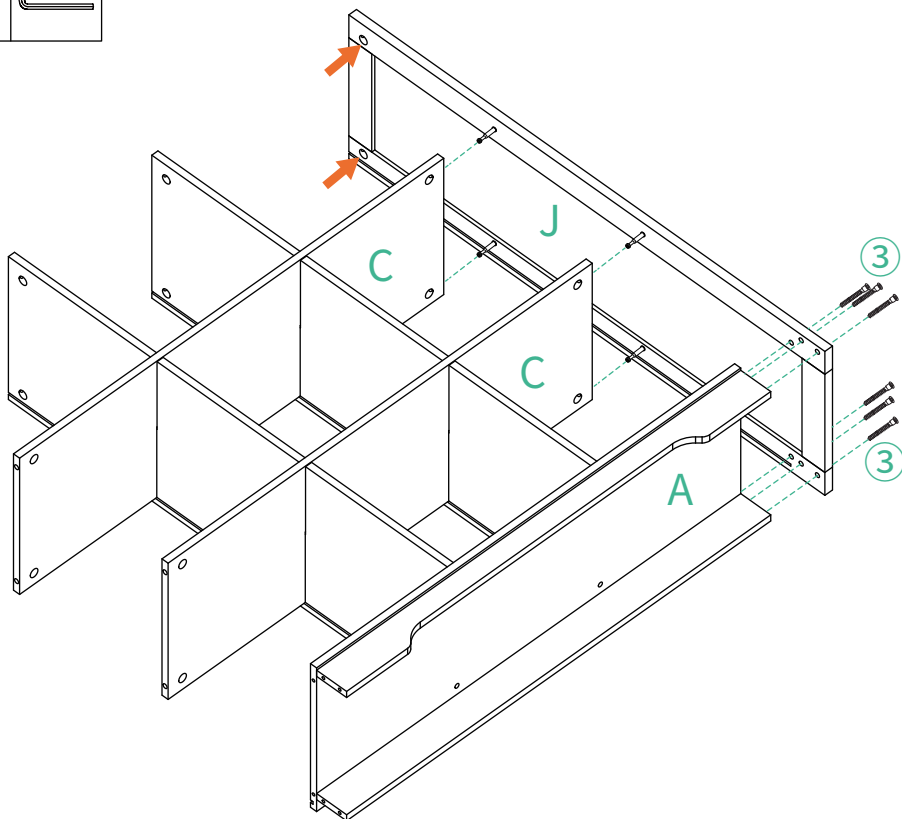
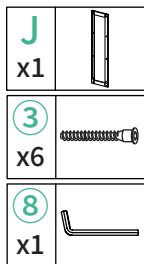

Assembly Instructions

N-6

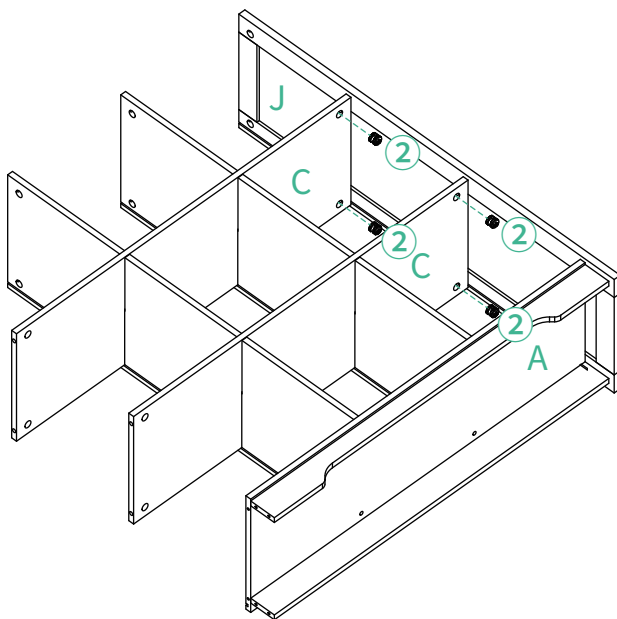
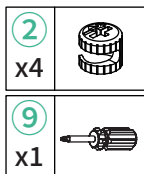

Installation
instructions
for eccentric
rod

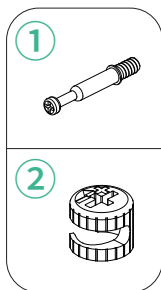

01

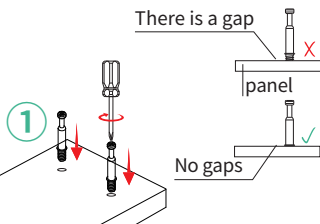

02

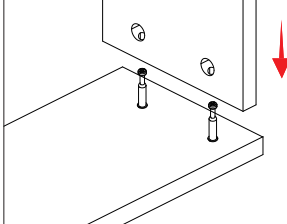

03

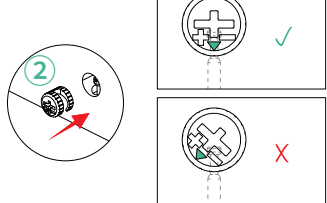

04

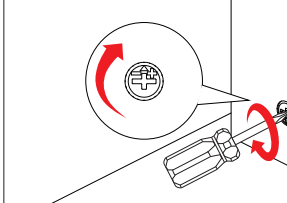

Assembly Instructions

N-7

Make sure the hole indicated by the arrow on panel I is facing inward during installation.

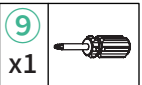
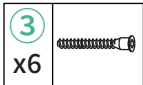
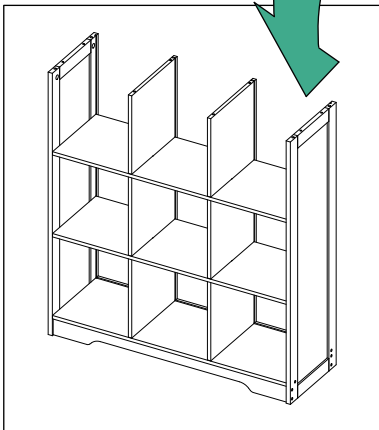
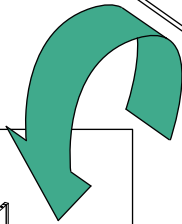
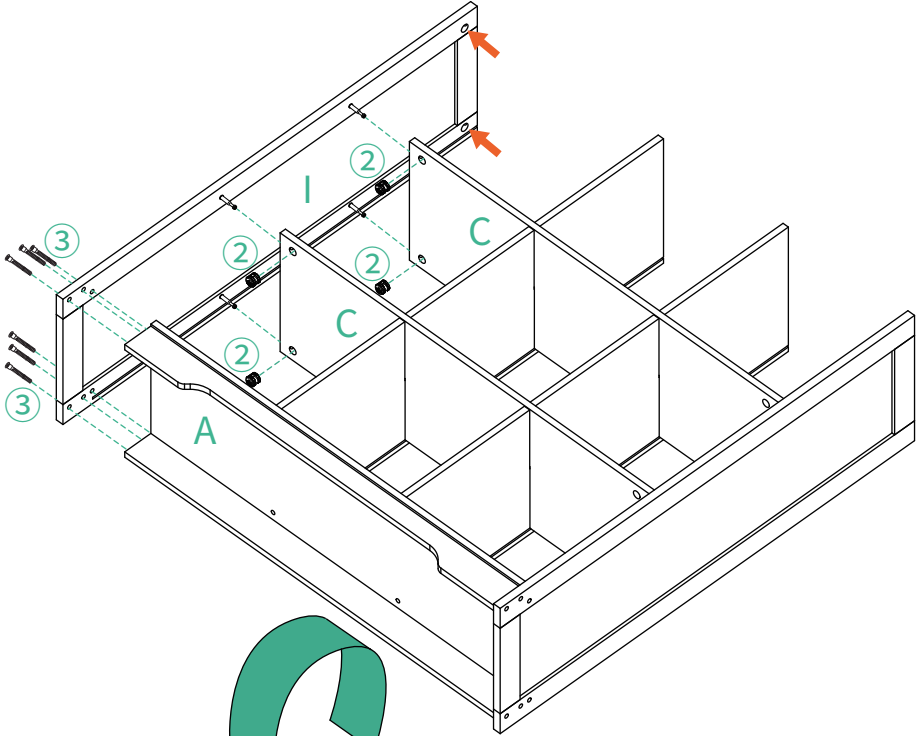

Assembly Instructions

N-8

Make sure the notch indicated by the arrow on panel E are facing the correct direction during installation.

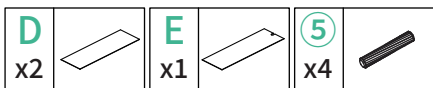
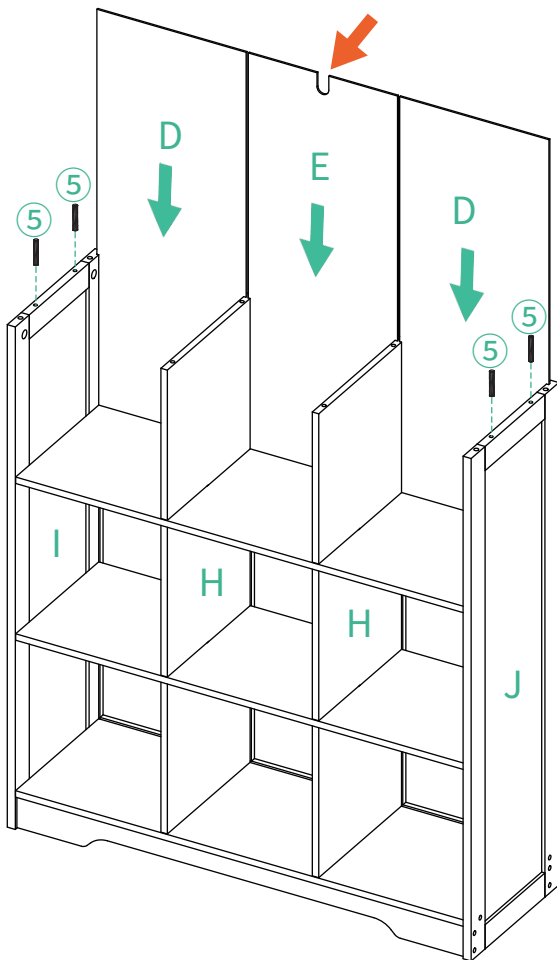

Assembly Instructions

N-9

Make sure the anti-tip bracket is installed in the correct direction, flush with the panel edge, and tighten screw ⑦-c about 50%.

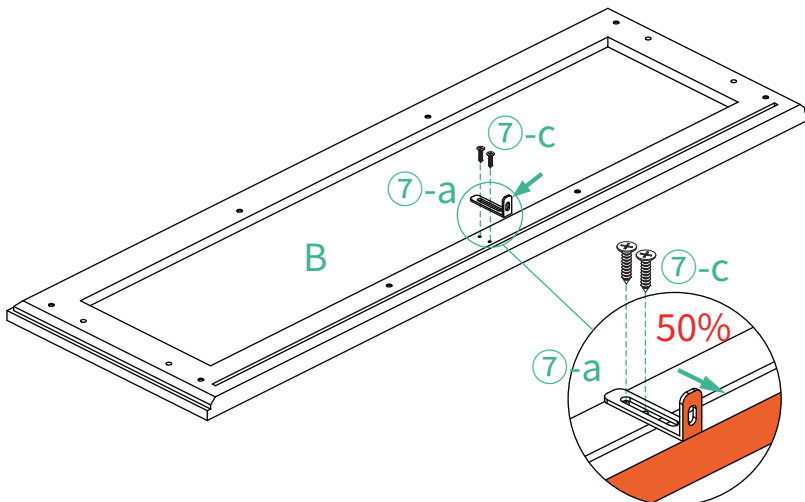
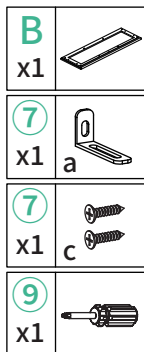

N-10

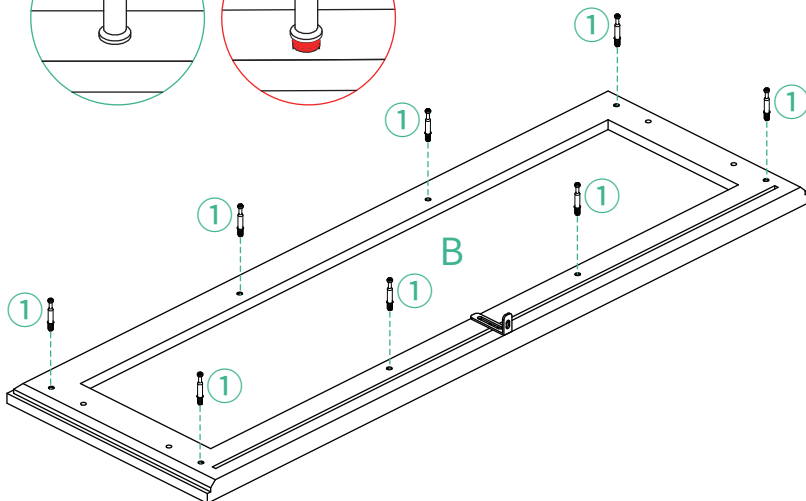
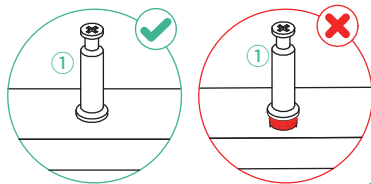
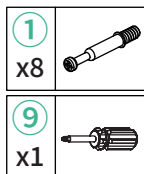

Assembly Instructions

N-11

Make sure the metal plate indicated by the arrow is facing backward when installing the top panel.

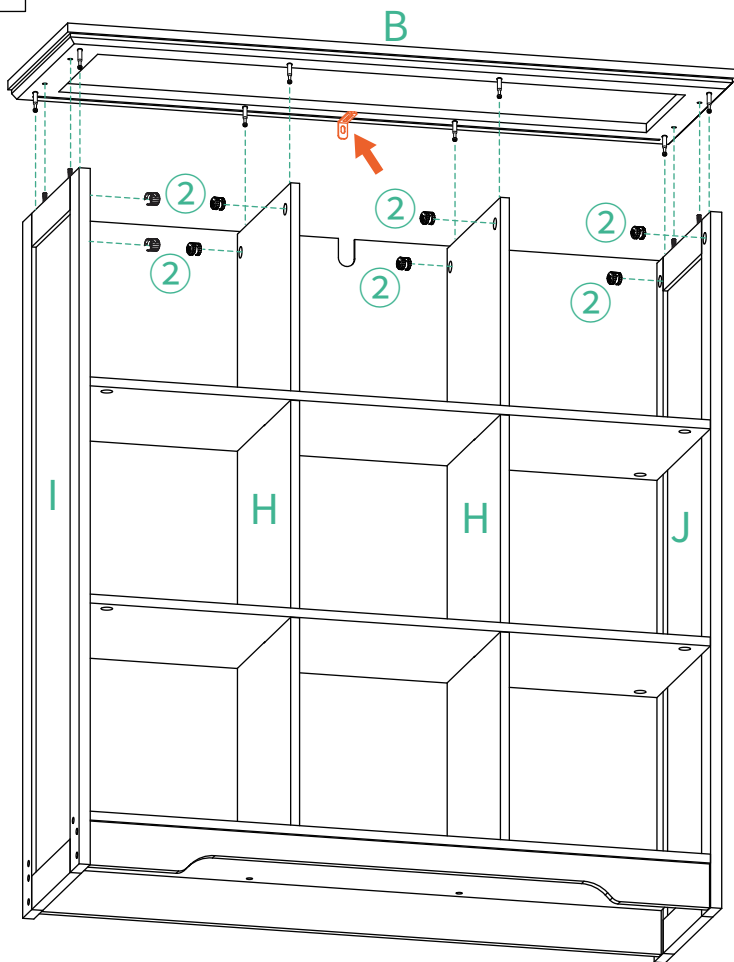
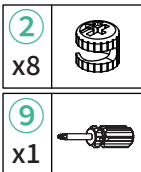

Assembly Instructions

N-12

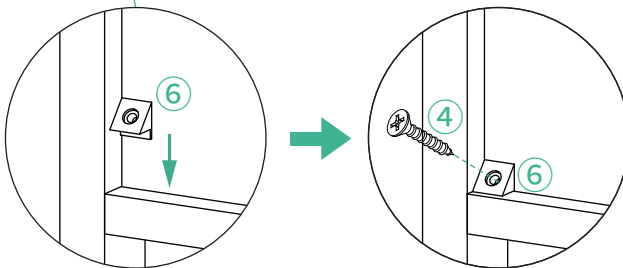
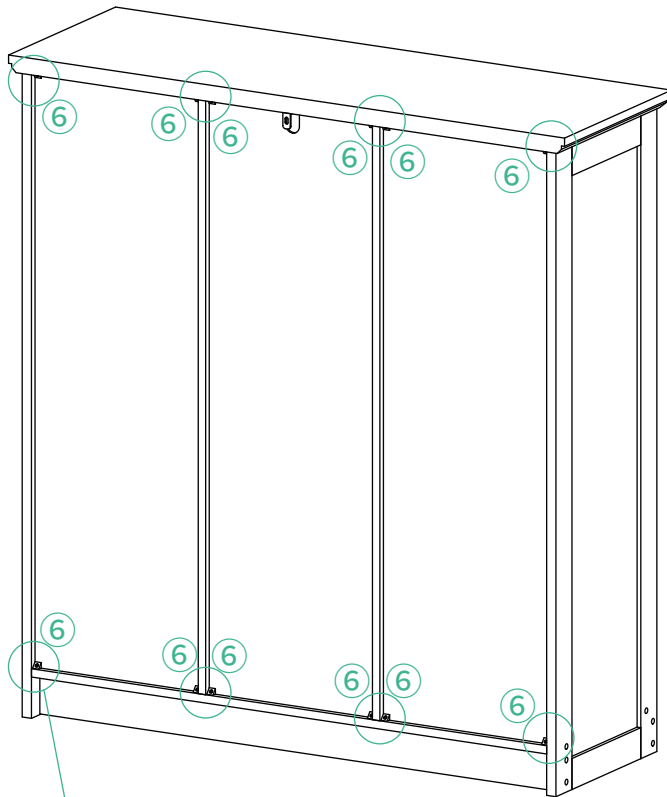

Assembly Instructions

N-13

Align Part ⑦-a on the wall and mark the hole location with a pen. Drill a 0.2-0.24 in diameter, 1.2-1.6 in depth hole at the marked spot, then use a hammer to fully insert Part ⑦-b. Finally, fasten ⑦-a to ⑦-b with Screw ⑦-d using a screwdriver.

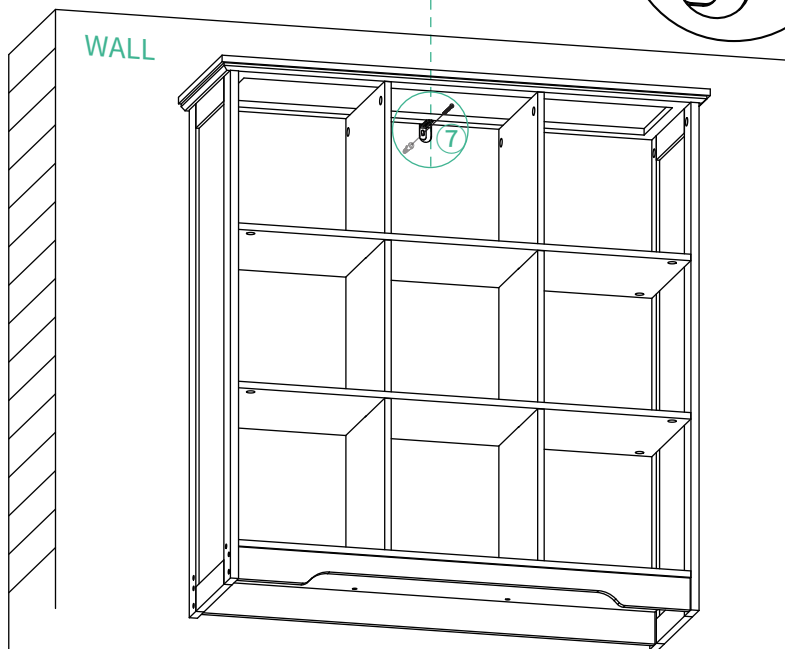
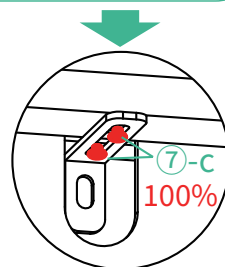
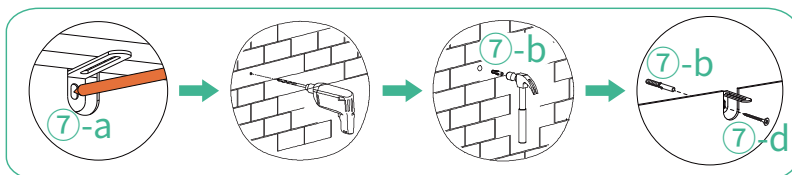
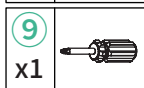
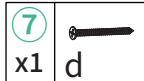
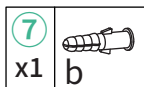

N-14

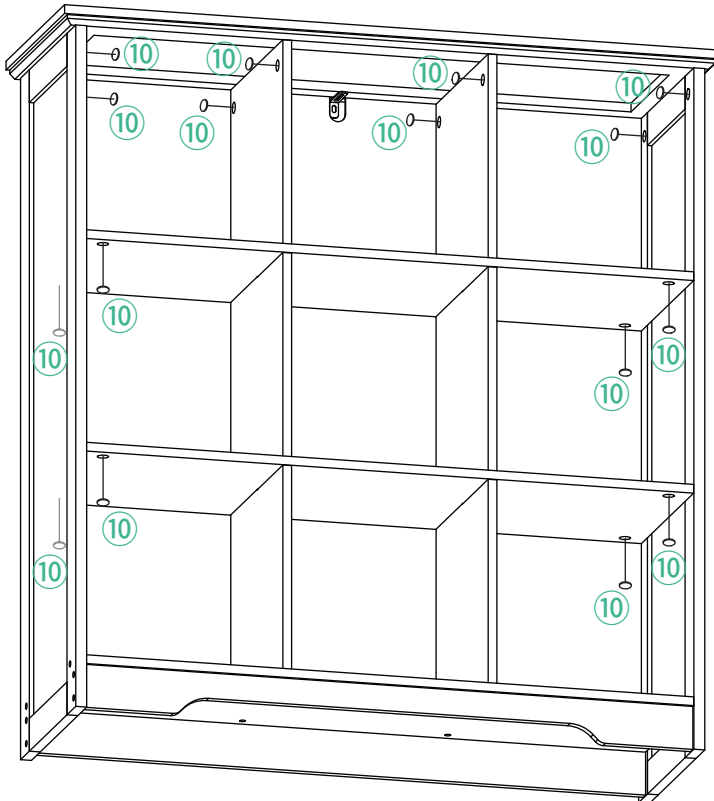
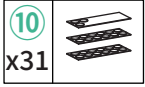



30 DAY Return Policy

If you're not completely satisfied with your purchase, please return the merchandise via our Official Customer Support. Unused merchandise can be refunded or exchanged within 30 days of purchase.



1-Year Warranty

We guarantee your product is free from defects in product material and workmanship for one (1) year starting from the date of purchase during normal use of household conditions. If your appliance fails to operate properly within our warranty period, we will arrange a new one. Replacement is free and all shipping costs are covered.



Quick Response within 24 Hours

If you are still unable to resolve the issue you are experiencing, please contact us immediately via our support email. It doesn't matter if the product has been installed or not, our customer support team will respond within 24 hours and assist you quickly and efficiently. The most efficient way to confirm your problem to us is to attach a video, which illustrates your product issues.

Problems You May Encounter

PART	PROBLEM	SOLUTION
Whole Product	Parts are missing, defective or having wrong parts in package.	Contact us via our after-sales phone or email. We will respond within 24 hours.
	Having issue(s) while reading the instruction or completing the assembly.	Contact us via our after-sales phone or email. We will respond within 24 hours.
	Encountering non - human caused damage during use.	If the product is damaged due to non - human causes, please keep the product and send us photos of it. We will ascertain the cause of the product damage within 48 hours and provide you with a satisfactory solution.
Furniture Surface	Surface is broken, scratched or lack of some screw holes.	Contact us via our after-sales phone or email. We will respond within 24 hours.
	The screw holes that on the board and the frame don't line up.	<ol style="list-style-type: none"> 1. Tighten the screws only 70% of the way. Do not fully tighten the screws until all parts are aligned. 2. Adjust the board and frame until the holes align, then fully tighten all screws.
	Surface is uneven or not tight that has gaps after being assembled.	<ol style="list-style-type: none"> 1. Loosen the screws in the uneven or gap positions; adjust until the surface is flat and tight, and then tighten the screws. 2. If your problem still can't be solved, please feel free to contact us.
Structure Frame	Components are bent, broken, chipped, rusted, or damaged.	Contact us via our after-sales phone or email. We will respond within 24 hours.
	The furniture is unstable after being assembled.	<ol style="list-style-type: none"> 1. Check if all screws are fully tightened. 2. Read through the manual and check if any parts are installed incorrectly or missing. 3. If the problem persists, please contact us.
	Encountering non - human caused damage during use.	If the product is damaged due to non - human causes, please keep the product and send us photos of it. We will ascertain the cause of the product damage within 48 hours and provide you with a satisfactory solution.

We are committed to providing our customers with premium quality products and convenient customer service.

MADE IN CHINA