

ROUND WOOD ACCENT TABLE

Assembly Instructions

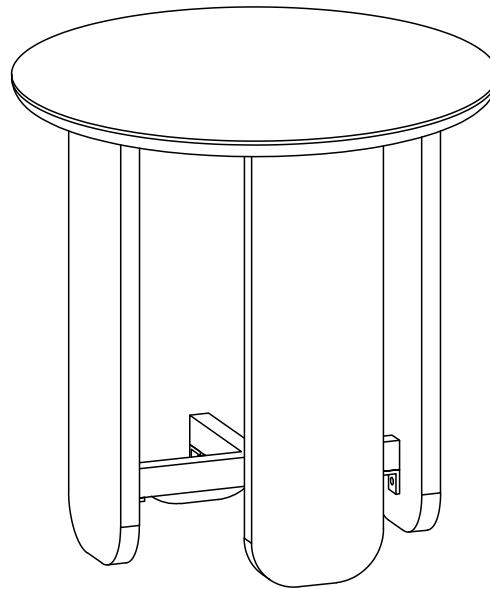

**Thanks for bringing
our Couture into
your home**

Everything we make is incredibly simple to set up, including your new Accent table. You won't need any additional tools.

Parts List

- A X 1
Wooden Top
- B X 4
Wooden Legs
- C X 1
Leg Support
- D X 4
Assembly Plates

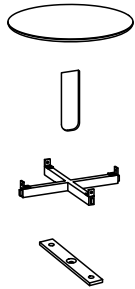

Hardware List

- HW1 X 1
ALLEN KEY 5mm
- HW2 X 12
JCB BOLT 20X8mm
- HW3 X 12
FLAT WASHER 25X8mm
- HW4 X 4
CSK BOLT 25X8mm



1

Attach the Assembly Plate (D) to the legs (B) by using the Allen Key (HW1) to screw in the CSK Bolts (HW4) into the middle holes of the Assembly Plate as shown. Repeat for all the legs.

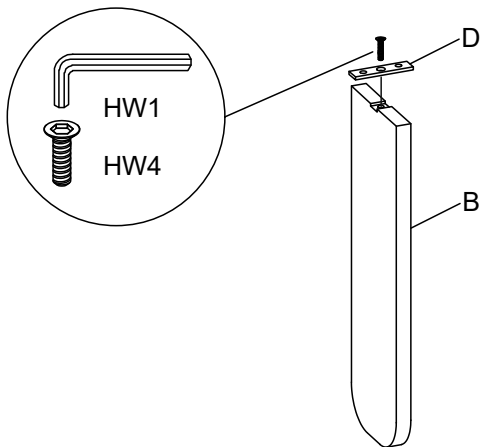

2

Attach the Leg Support (C) to the legs (B) by using the Allen Key (HW1) to screw in the JCB bolts (HW2) with the Flat Washers (HW3) as shown. Firmly tighten the bolts.

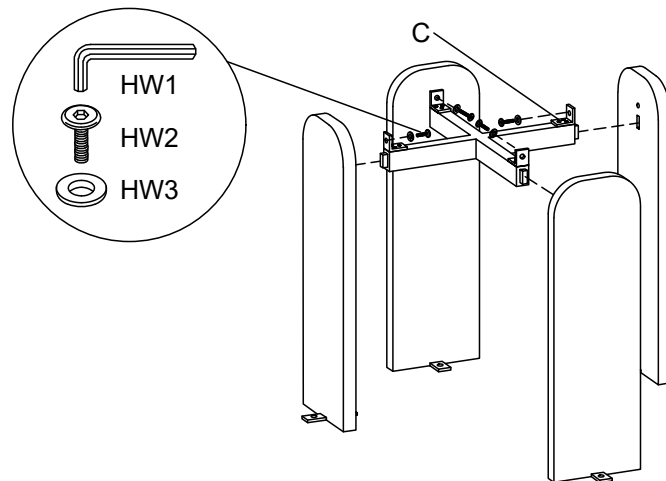

3

Place the Wooden Top (A) upside down on a flat, soft surface. Align the screw holes on the Top to the screw holes on the assemble base. Place the Flat Washer (HW3) on the JCB Bolts (HW2) and use the Allen Key (HW1) to screw in the bolts to attach the legs to the Top. Firmly tighten the bolts.

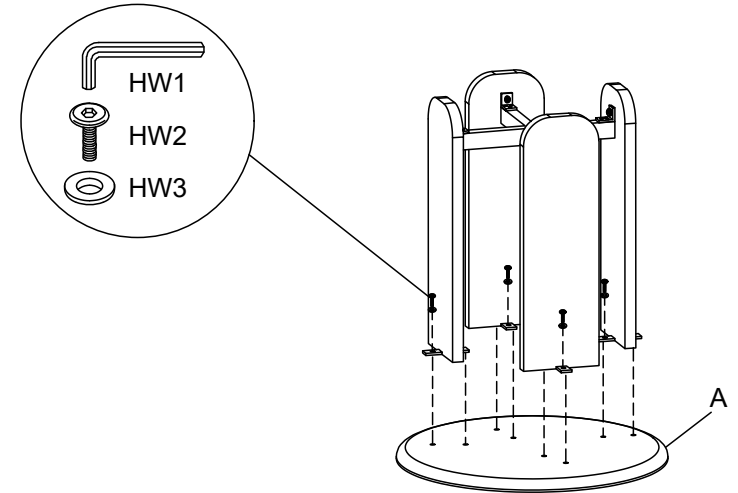

4

Carefully turn the accent table upright. Place the accent table in the place where you will use it. We'd love to see it - just tag us (We're @safavieh) and use the hashtag #safavieh on Instagram.

