

## LOVE SEAT

**IMPORTANT: PLEASE READ COMPLETE INSTRUCTION SHEET PRIOR TO ASSEMBLY!** Identify all parts packed in carton against the parts list. Remove all protective materials, place parts on a nonabrasive surface to avoid scratching. If any parts are missing or damaged, DO NOT attempt to assemble. Please contact our customer service center

### Step 1

Attach the left and right arms (A&B) to the back frame (D) using four bolts (E) and metal washers (G). **Do not tighten the bolts completely!**

### Step 2











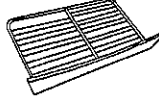

Attach the seat frame (C) to the left and right arms (A&B) using four bolts (F) and metal washers (G). **Do not tighten the bolts completely!**

### Step 3

Connect the back frame (D) and the seat frame (C) using three bolts (F) and metal washers (G). Tighten the bolts completely by using the Allen wrench (I). Cover all the bolts with the plastic bolt caps (H).

### Step 4

Turn the assembled love seat into the upright position. Place the seat cushion (J), back cushion (K), and toss pillows (L) on the loveseat. Your love seat is now ready for use.

PARTS LIST							
A	LEFT ARM (when sitting)		1	G	METAL WASHER		11
B	RIGHT ARM (when sitting)		1	H	PLASTIC BOLT CAP		11
C	SEAT FRAME		1	I	ALLEN WRENCH		1
D	BACK FRAME		1	J	SEAT CUSHION		2
E	ALLEN BOLT M6x25mm		4	K	BACK CUSHION		2
F	ALLEN BOLT M6x35mm		7	L	TOSS PILLOW		2

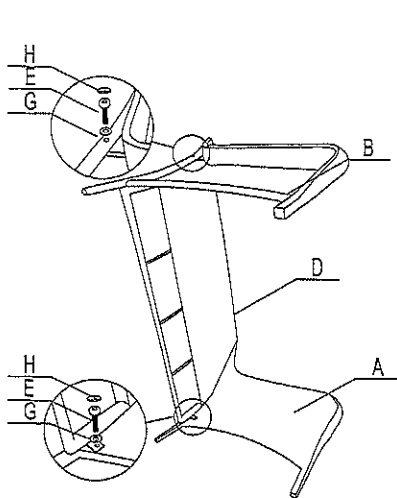

Step 1

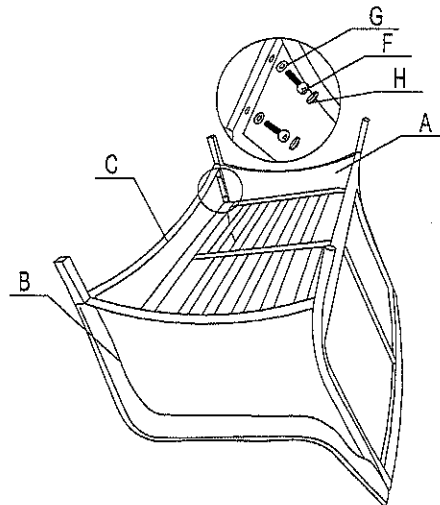

Step 2

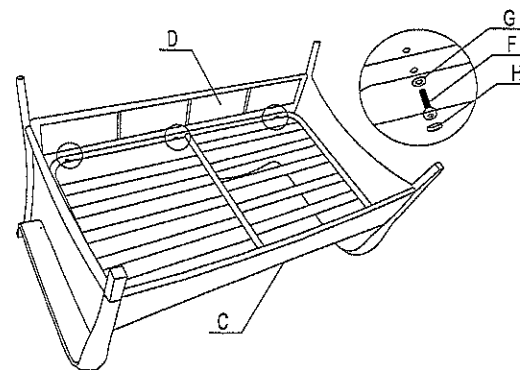

Step 3

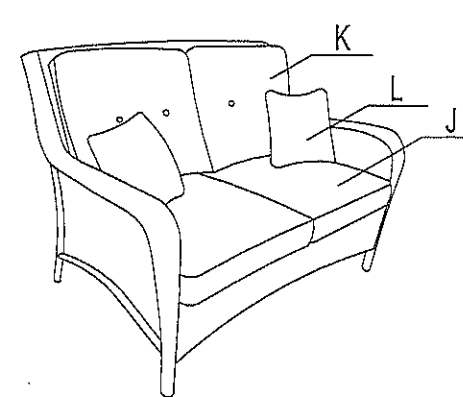

Step 4

## CHAT CHAIR

**IMPORTANT: PLEASE READ COMPLETE INSTRUCTION SHEET PRIOR TO ASSEMBLY!** Identify all parts packed in carton against the parts list. Remove all protective materials, place parts on a nonabrasive surface to avoid scratching. If any parts are missing or damaged, **DO NOT** attempt to assemble. Please contact our customer service center

### Step 1

Attach the left and right arms (A&B) to the back frame (D) using four bolts (E) and metal washers (G). **Do not tighten the bolts completely!**

### Step 2











Attach the seat frame (C) to the left and right arms (A&B) using four bolts (F) and metal washers (G). **Do not tighten the bolts completely!**

### Step 3

Connect the back frame (D) and the seat frame (C) using two Allen bolts (I) and metal washers (G). Tighten the bolts completely by using the Allen wrench (I). Cover all the bolts with the plastic bolt caps (H).

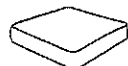
### Step 4

Turn the assembled chair into the upright position. Place the seat cushion (J) and back cushion (K) on the chair. Your chair is now ready for use.

PARTS LIST							
A	LEFT ARM (when sitting)		1	G	METAL WASHER		10
B	RIGHT ARM (when sitting)		1	H	PLASTIC BOLT CAP		10
C	SEAT FRAME		1	I	ALLEN WRENCH		1
D	BACK FRAME		1	J	SEAT CUSHION		1
E	ALLEN BOLT M6x25mm		4	K	BACK CUSHION		1
F	ALLEN BOLT M6x35mm		6				

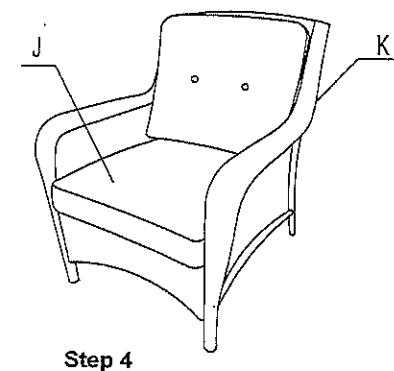
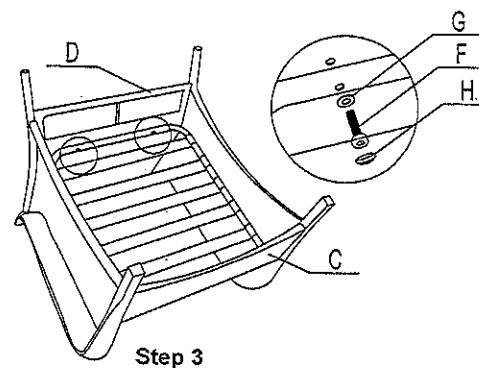
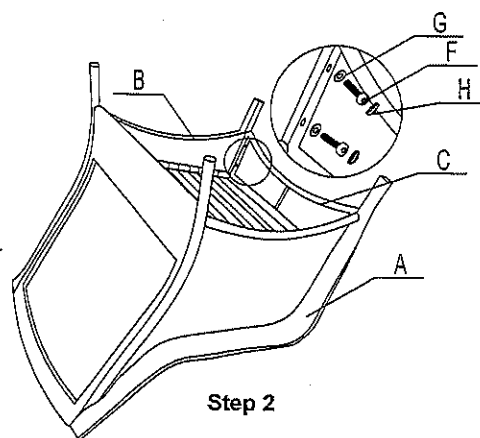
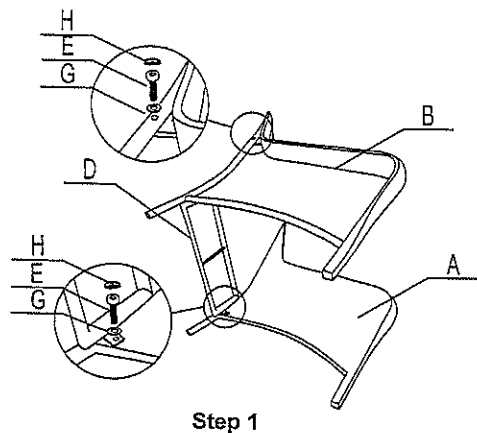

## COFFEE TABLE

**IMPORTANT: PLEASE READ COMPLETE INSTRUCTION SHEET PRIOR TO ASSEMBLY!** Identify all parts packed in carton against the parts list. Remove all protective materials, place parts on a nonabrasive surface to avoid scratching. If any parts are missing or damaged, DO NOT attempt to assemble. Please contact our customer service center

### Step 1







Attach the four table legs (A) to the table top (C) using four bolts (D) and metal washers (E). **Do not tighten the bolts completely!**

### Step 2

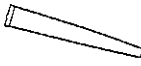
Attach the leg connector bracket (B) to the four table legs (A) using four bolts (D) and metal washers (E). Tighten all the bolts completely by using the hex wrench (G). Cover all the bolts with the plastic bolt caps (F). **IMPORTANT NOTE:** Each bolt should be tightened a few revolutions at a time, alternating between bolts in a cross corner (X) pattern to ensure your table is level.

### Step 3

Turn the assembled table into the upright position. Your table is now ready for use.

PARTS LIST							
A	TABLE LEG		4	E	METAL WASHER		8
B	LEG CONNECTOR BRACKET		1	F	PLASTIC BOLT CAP		8
C	TABLE TOP		1	G	HEX WRENCH		1
D	HEX BOLT M6x15mm		8				

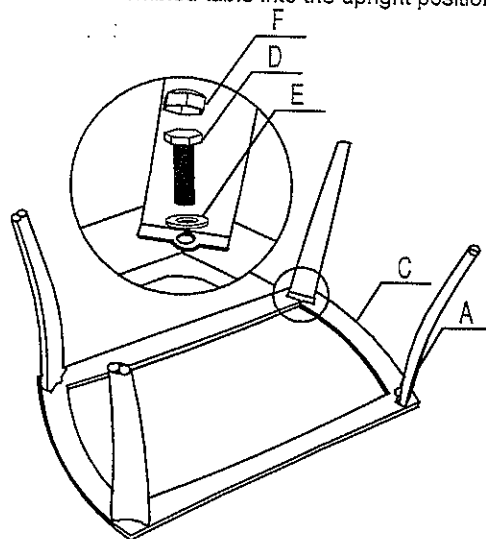

Step 1

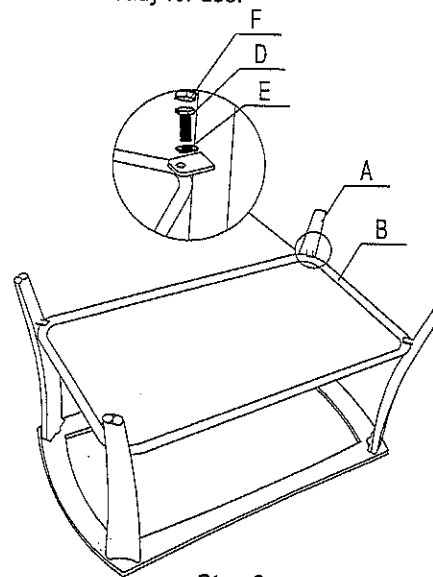

Step 2

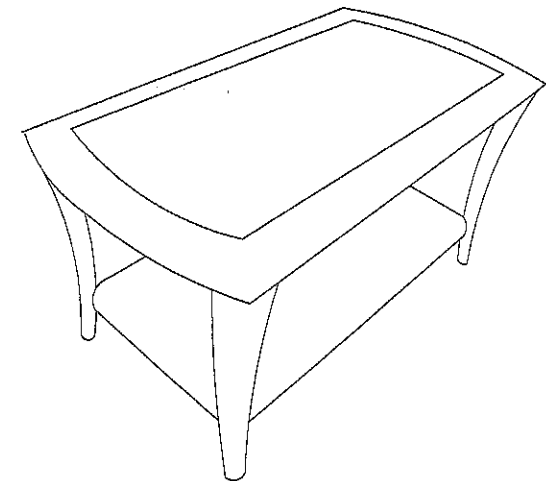

Step 3