

OWER MANUAL

Paddy Office Chair

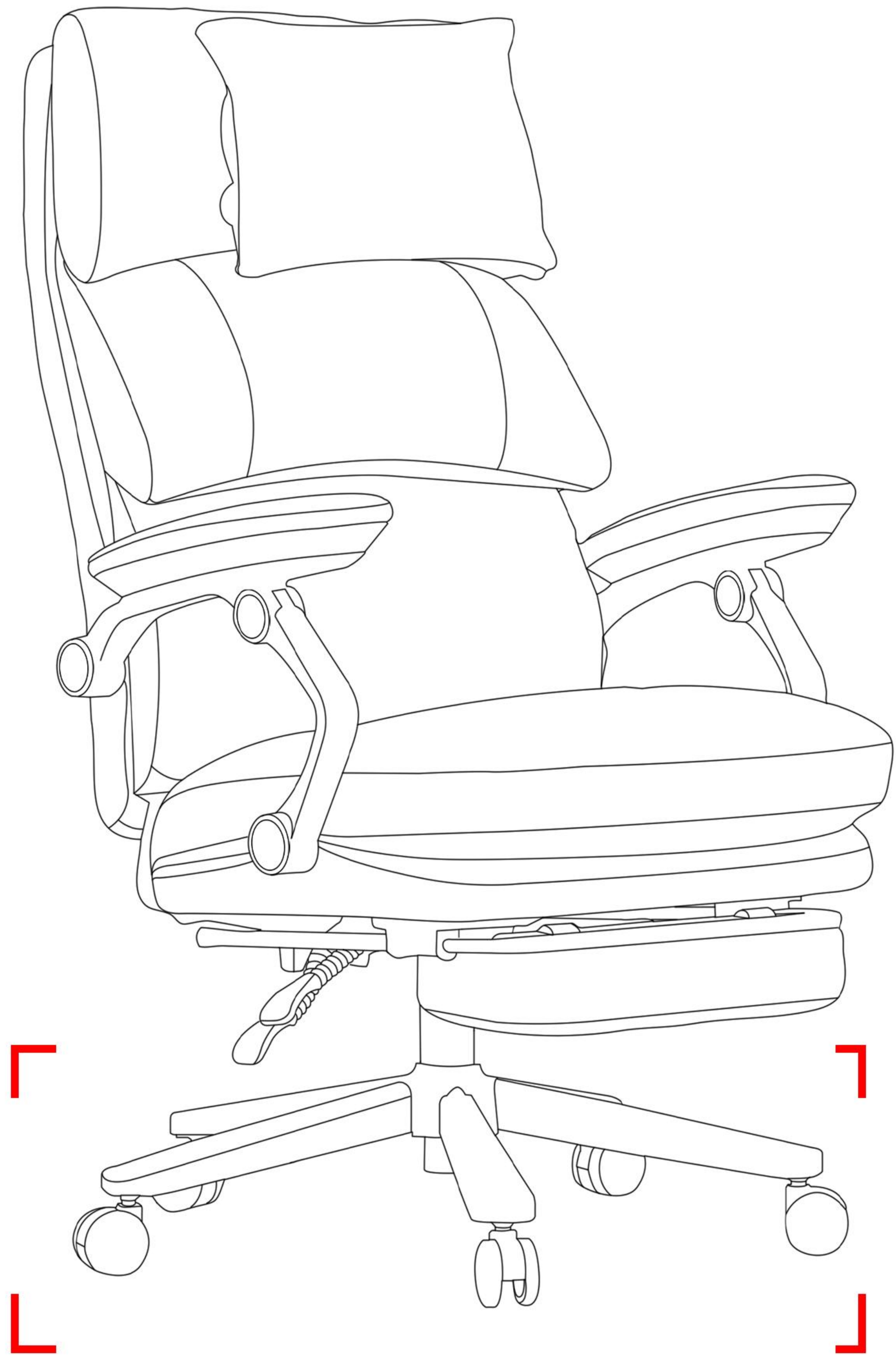

Before starting assembly, carefully open the packaging and identify each component. Before starting, please refer to the parts list to ensure that you have all the parts. Please be careful when assembling the equipment and always place the parts on a clean and soft surface.



1. Load the wheel into the bipod

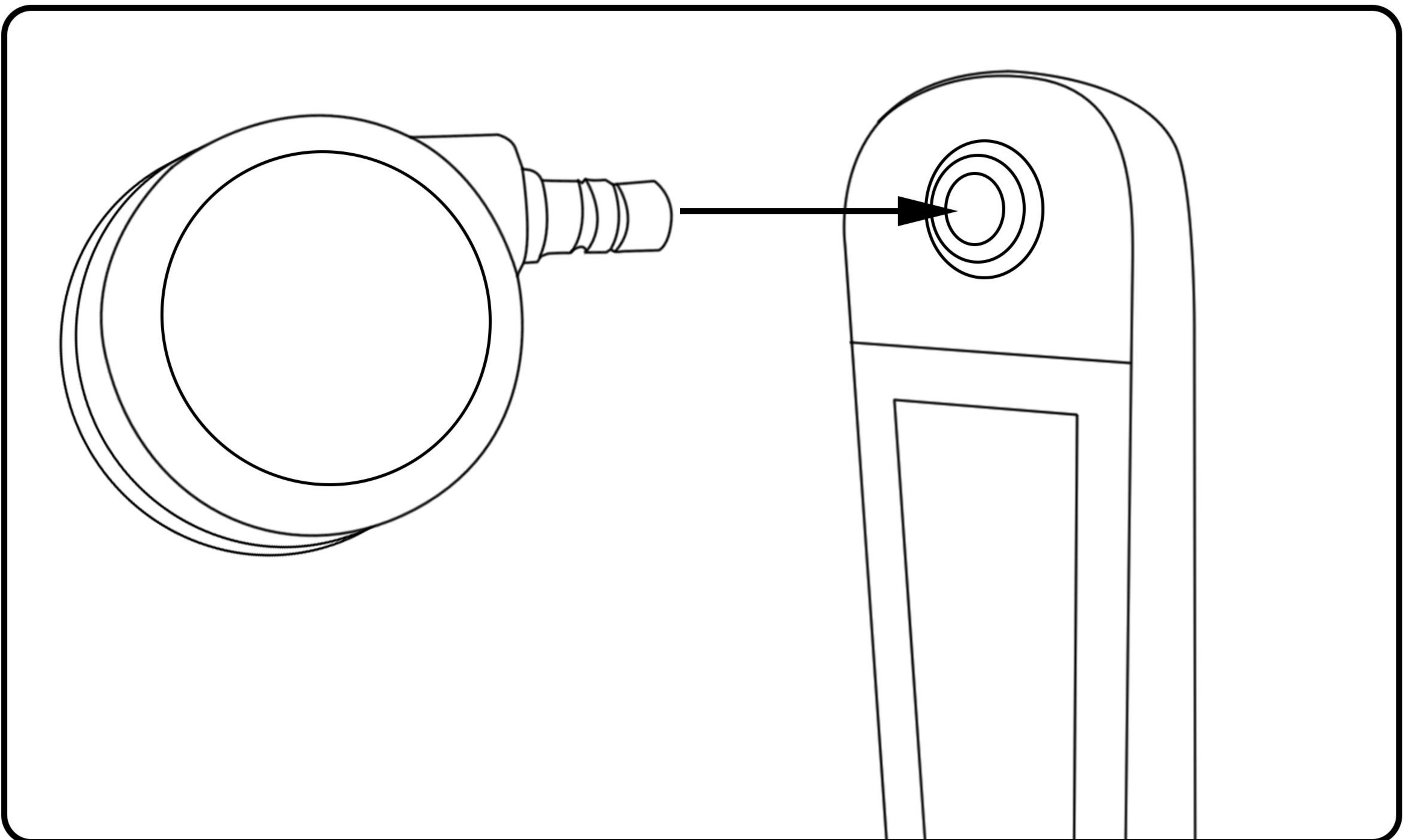

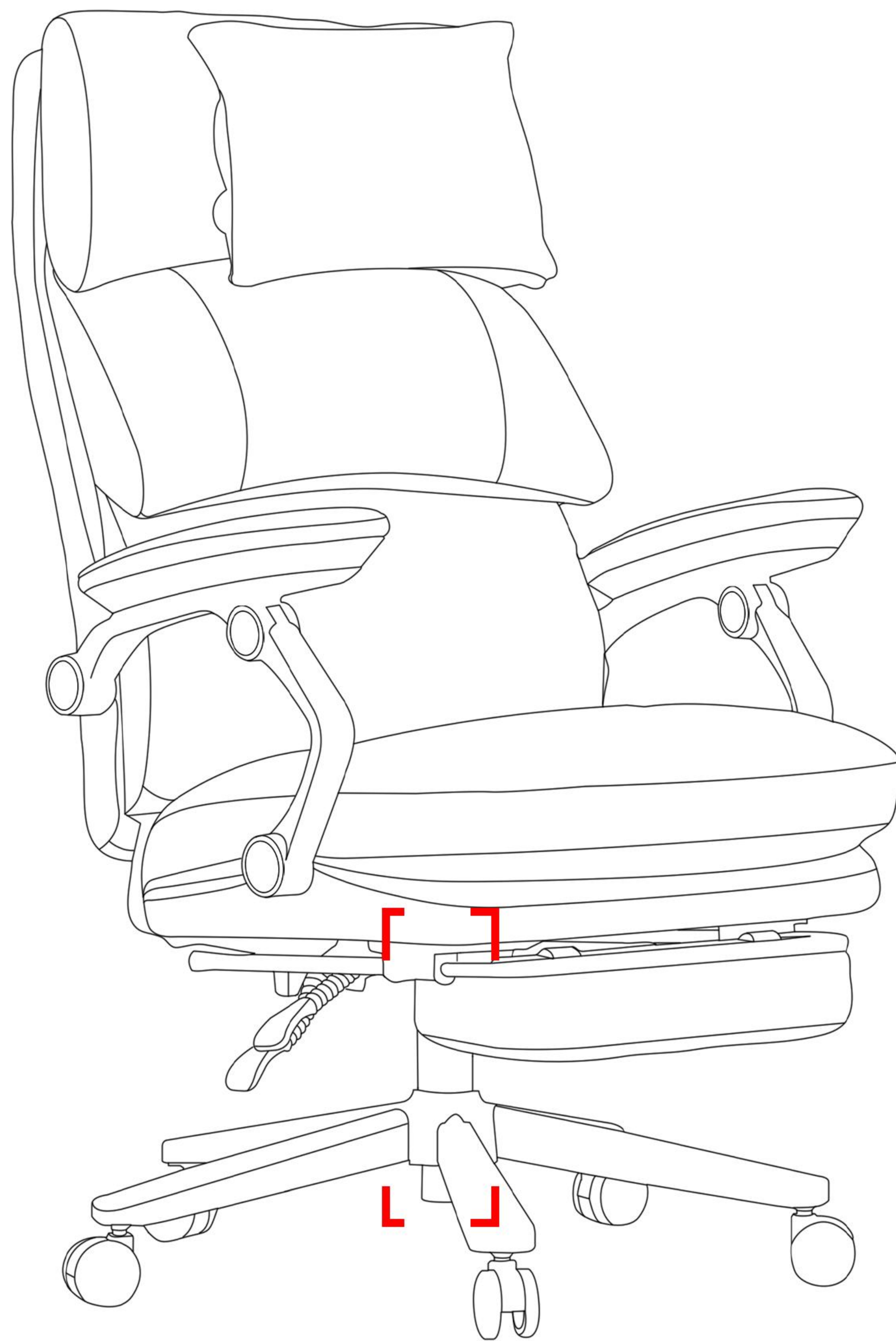

2. Insert the gas stick into the hole in the middle of the bipod

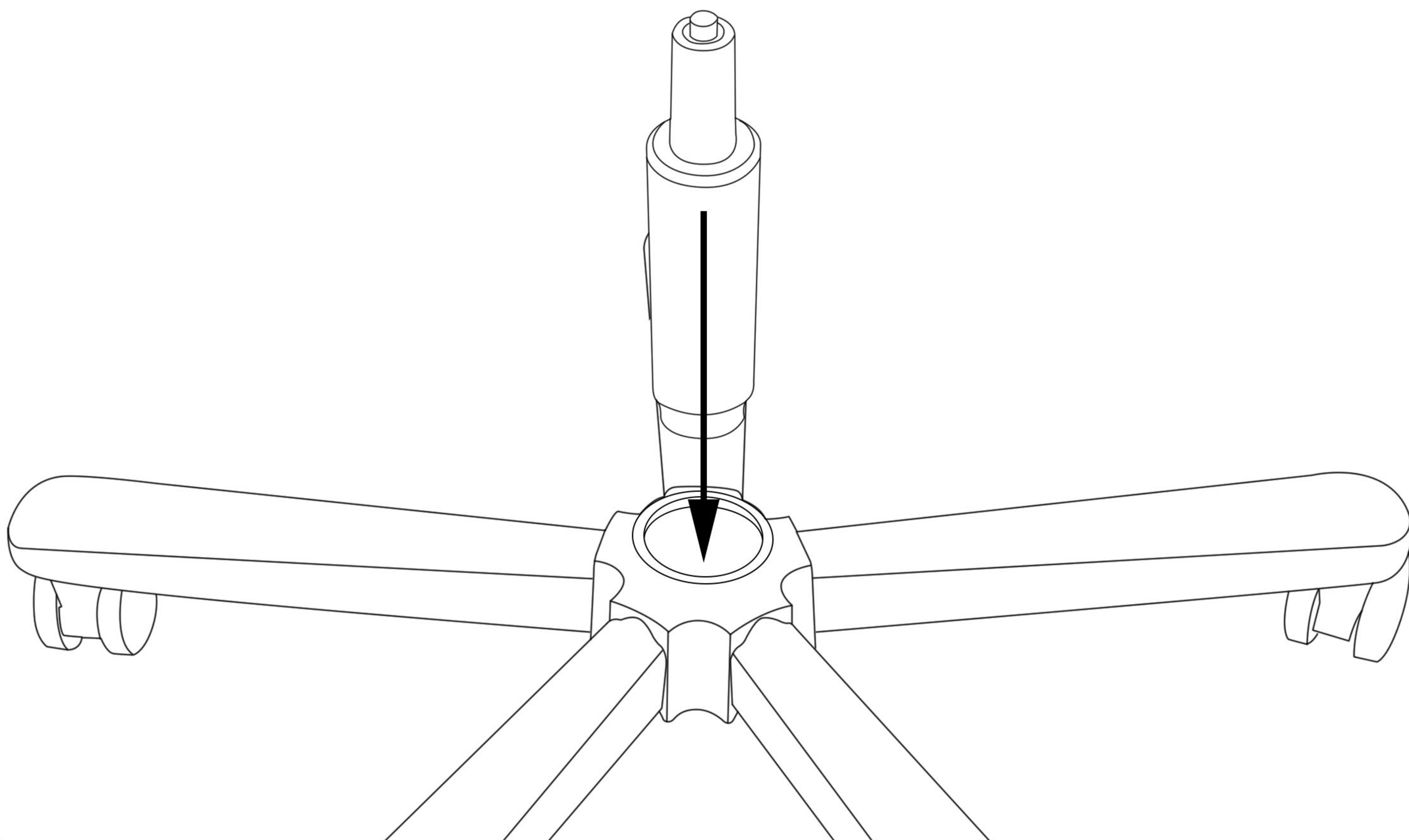

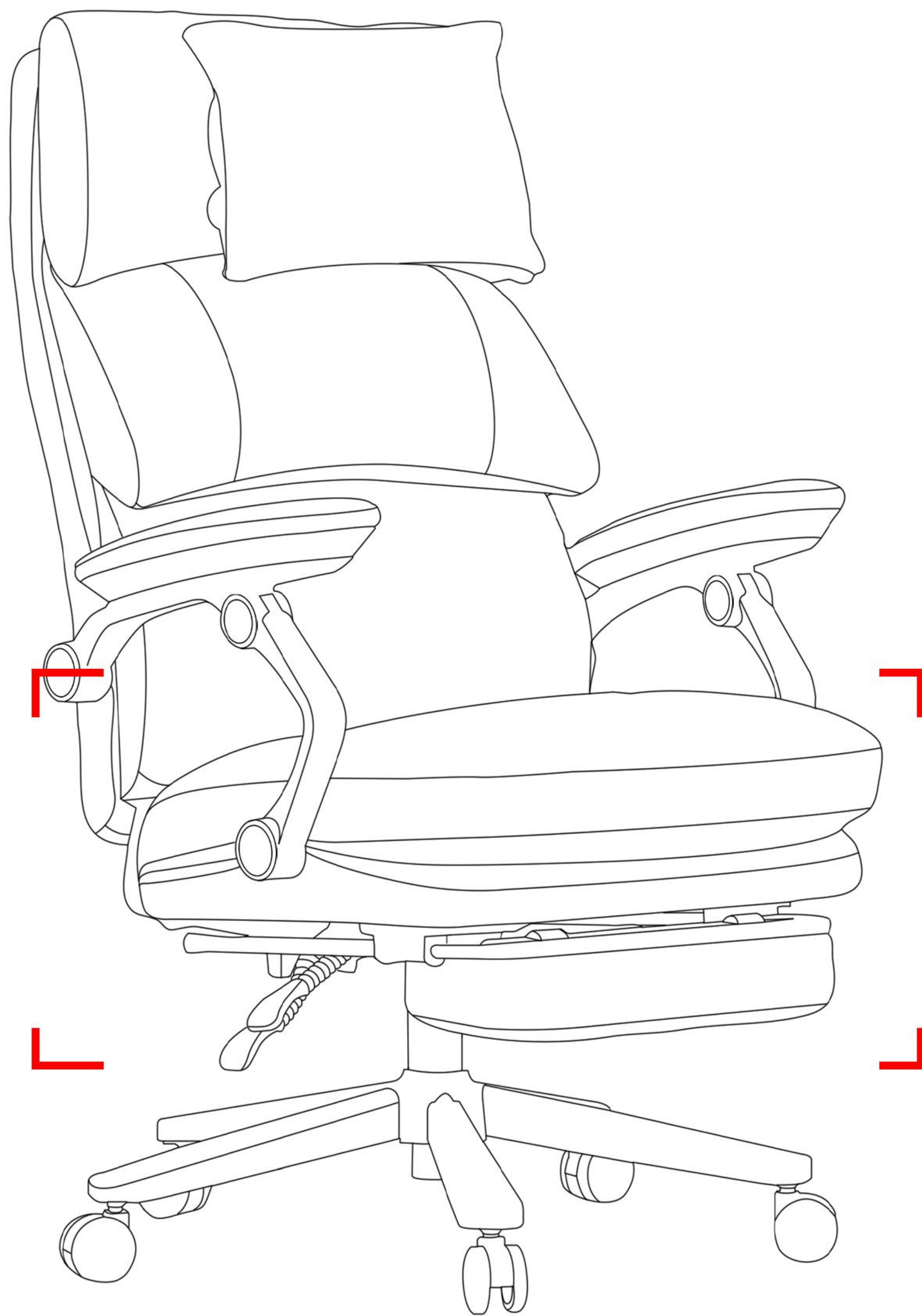

3. Connect cushion to gas stick

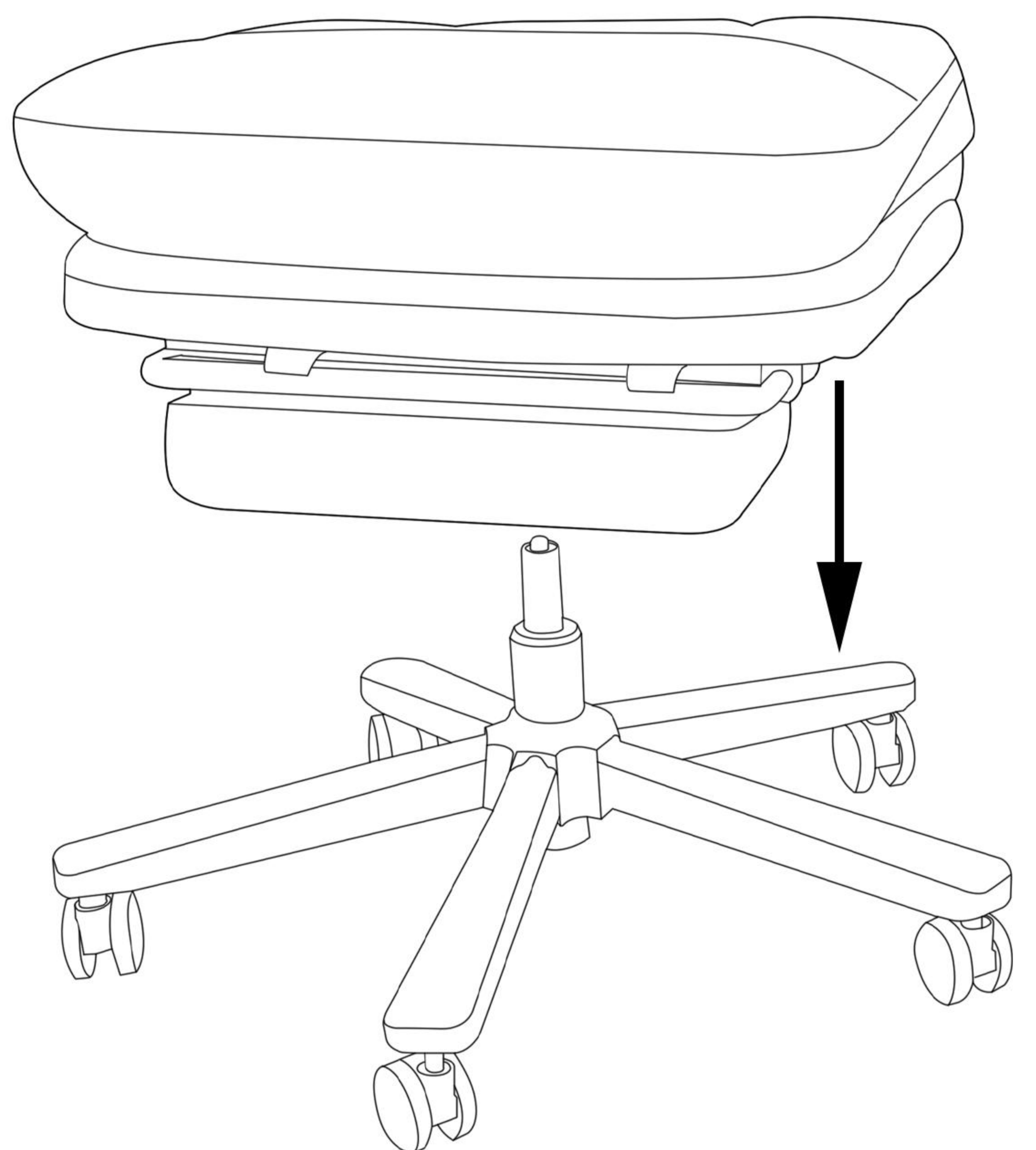
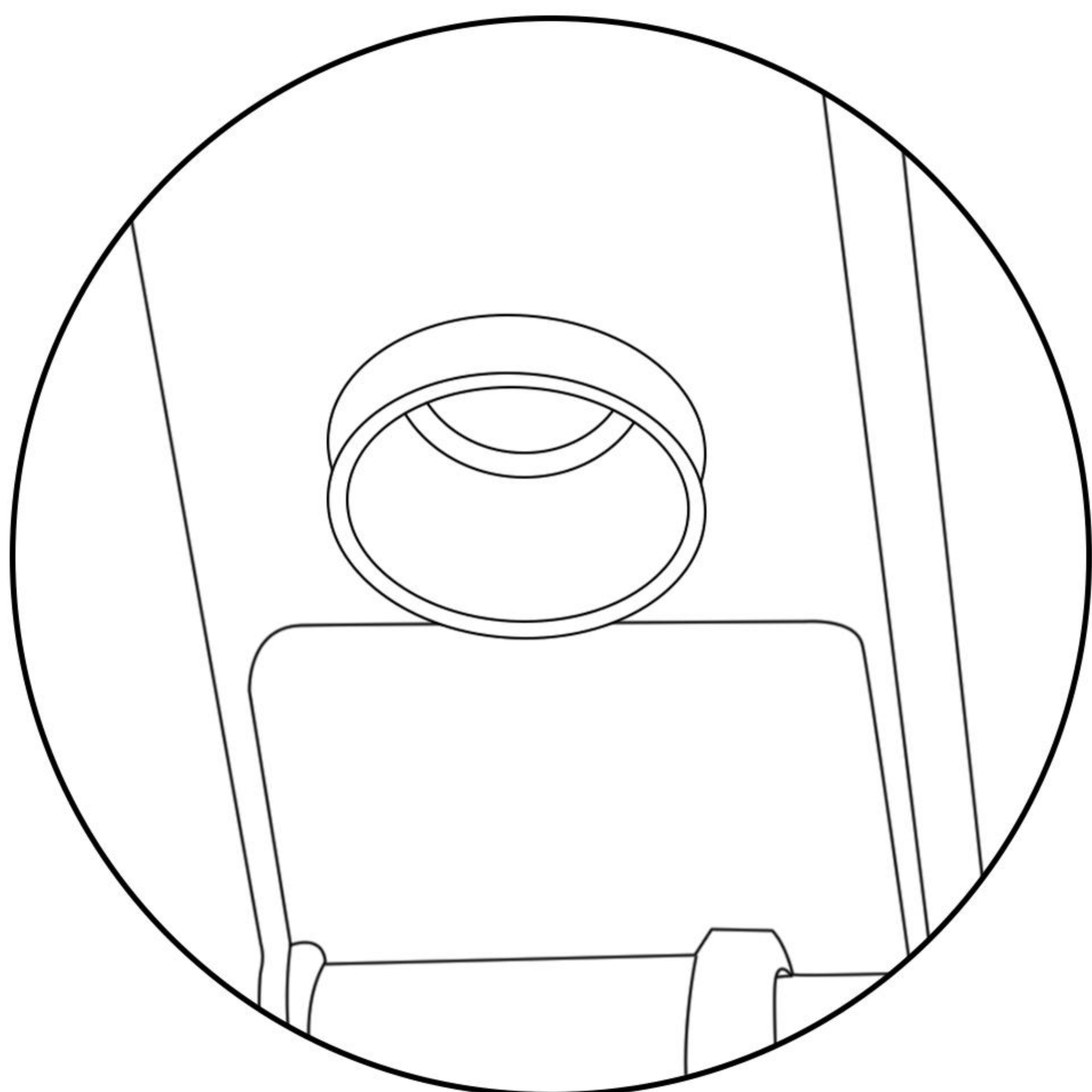

4. Install the bolt behind the cushion and secure it with a screw

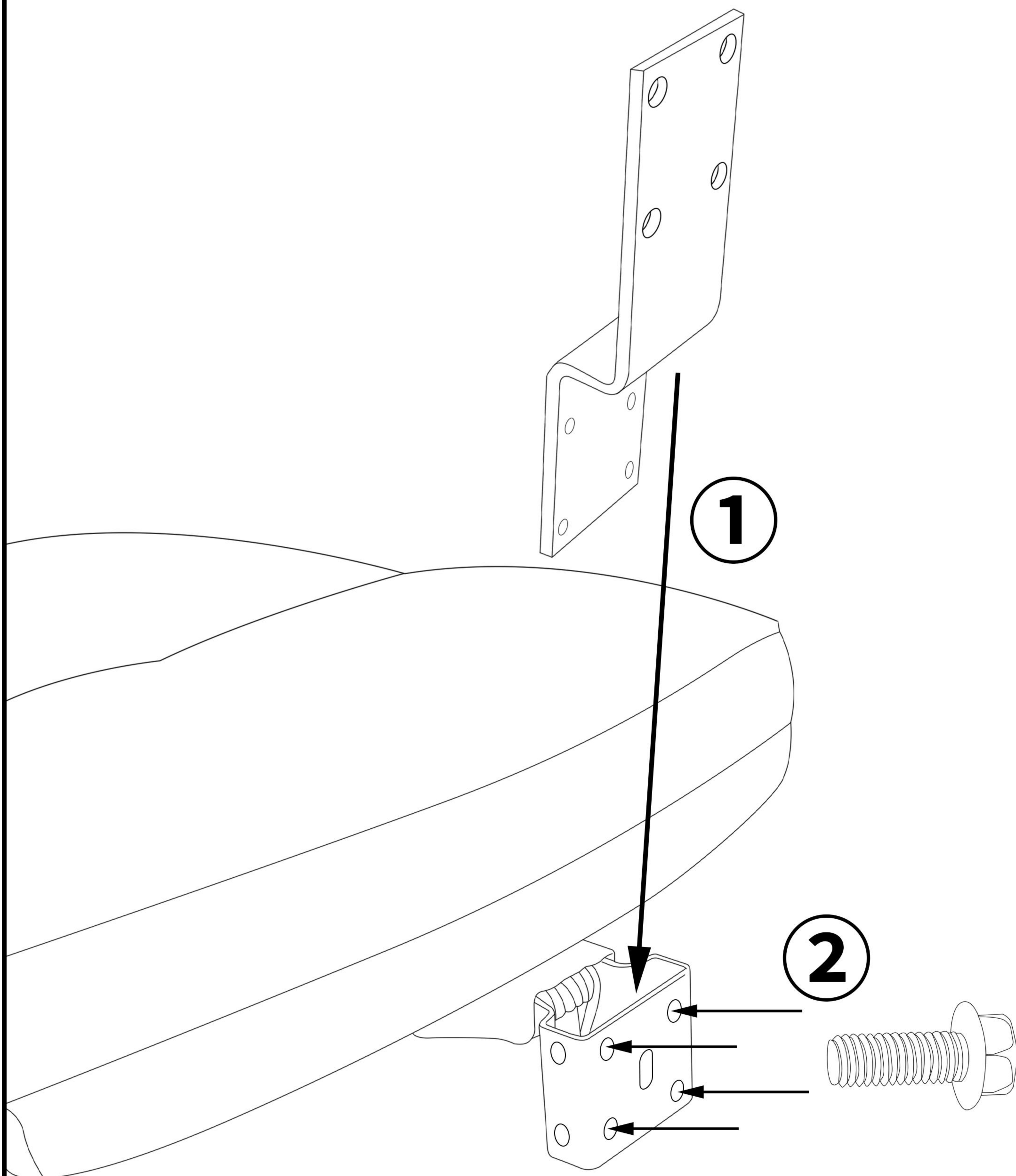

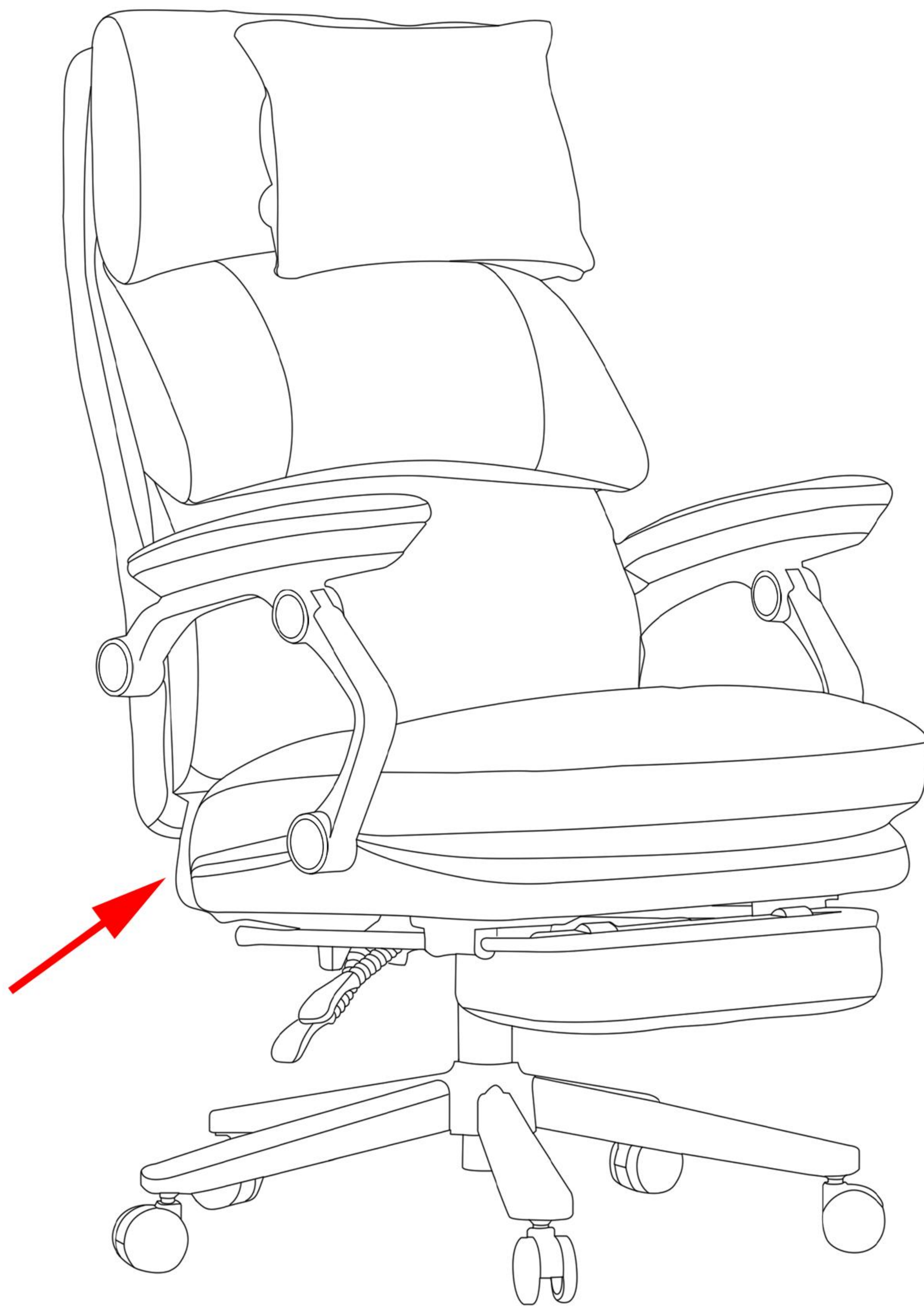

5. Connect the backbest to the bolt and fix it with a screw

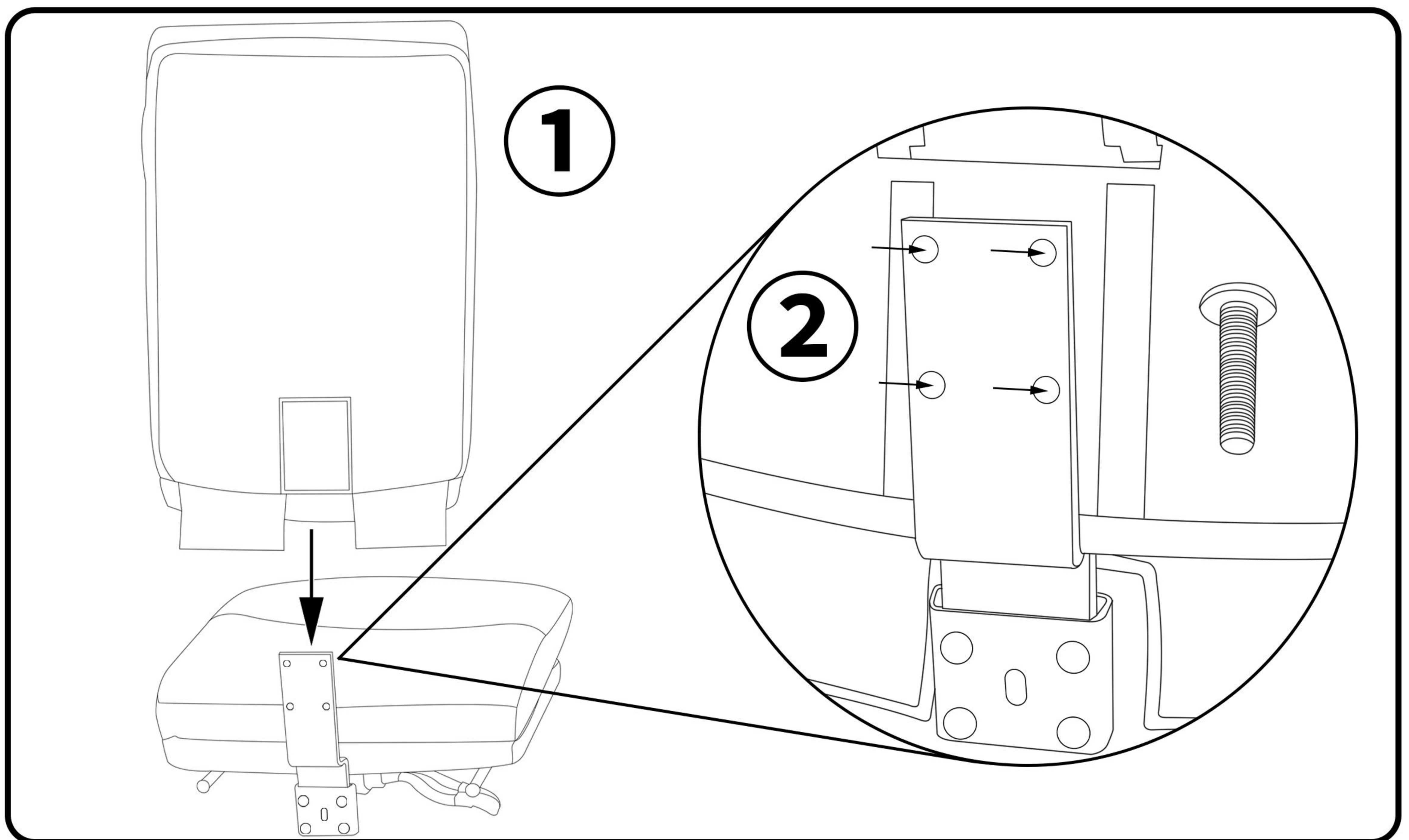

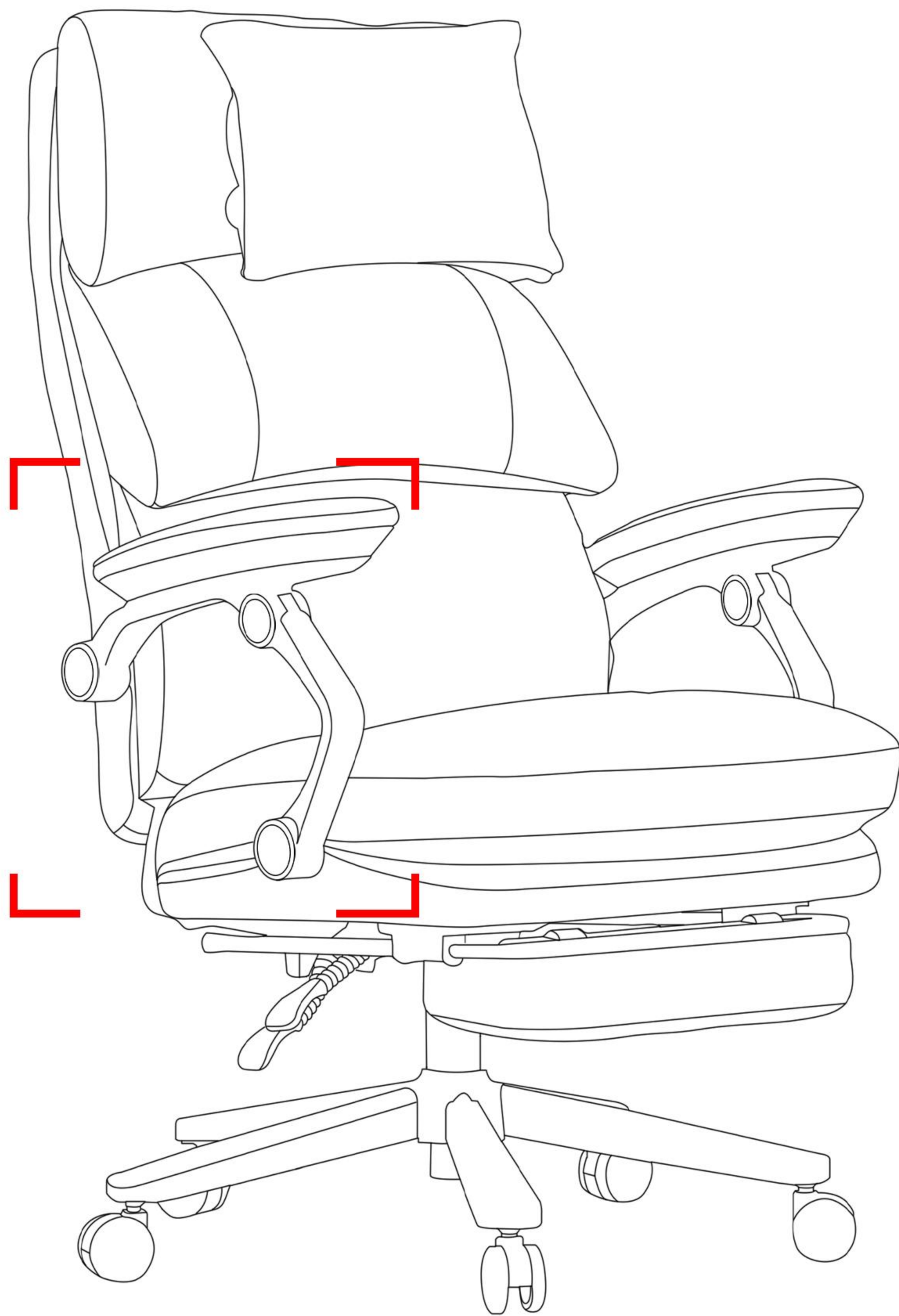

6. Connect the handrail to the seat and secure it with a screw

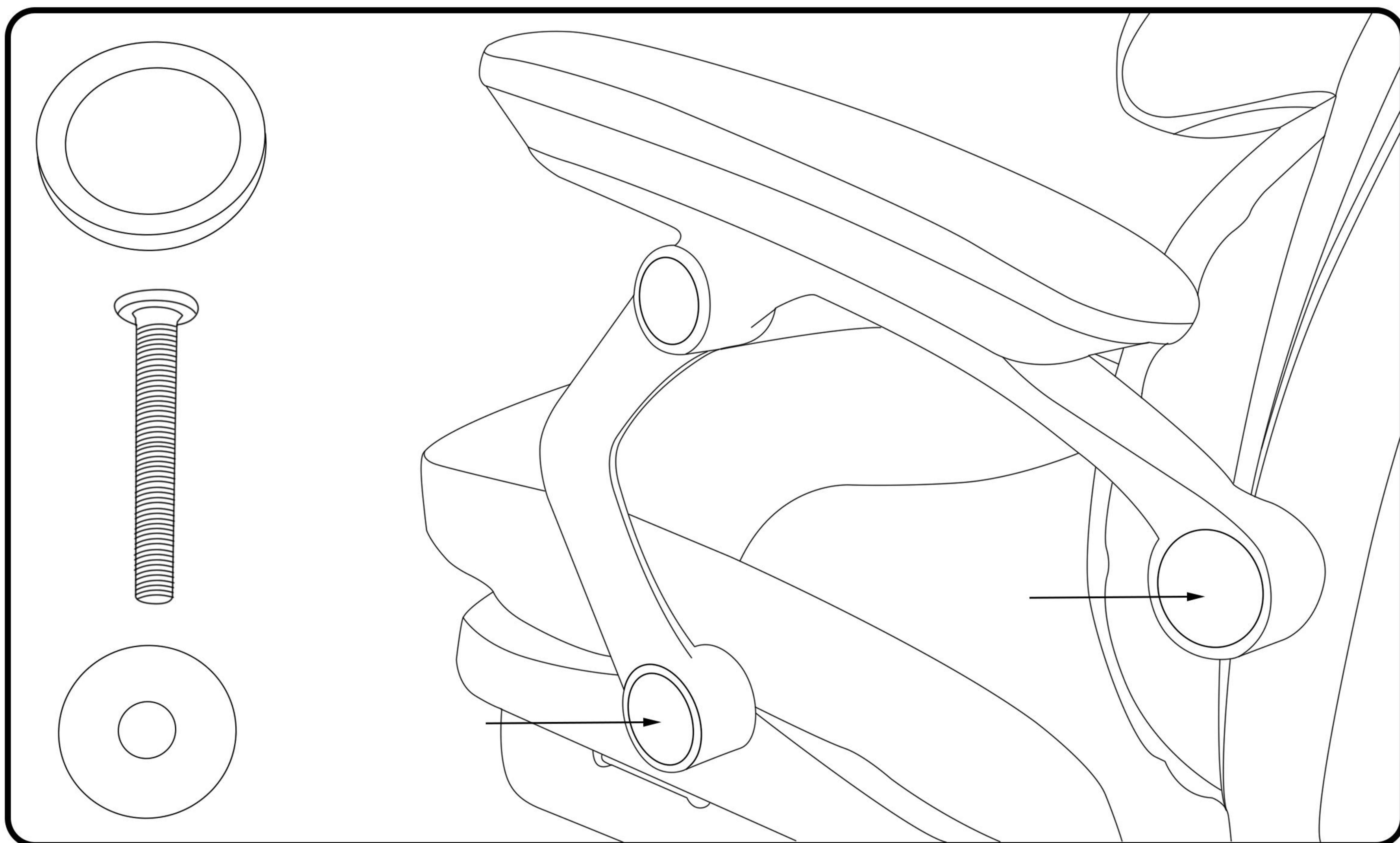

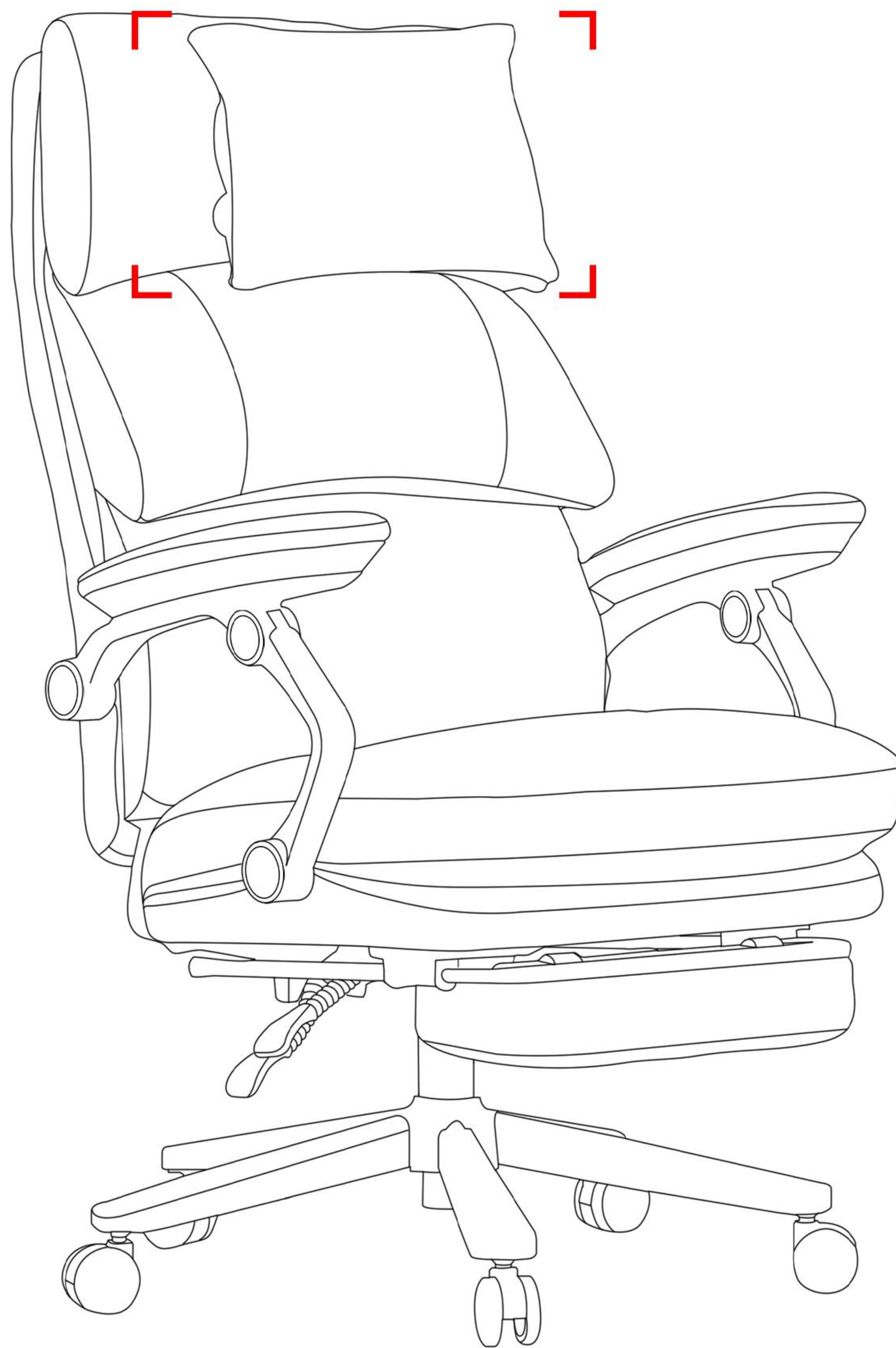

7. Place the headrest rope behind the top cushion cloth block of the backrest and lock it in place

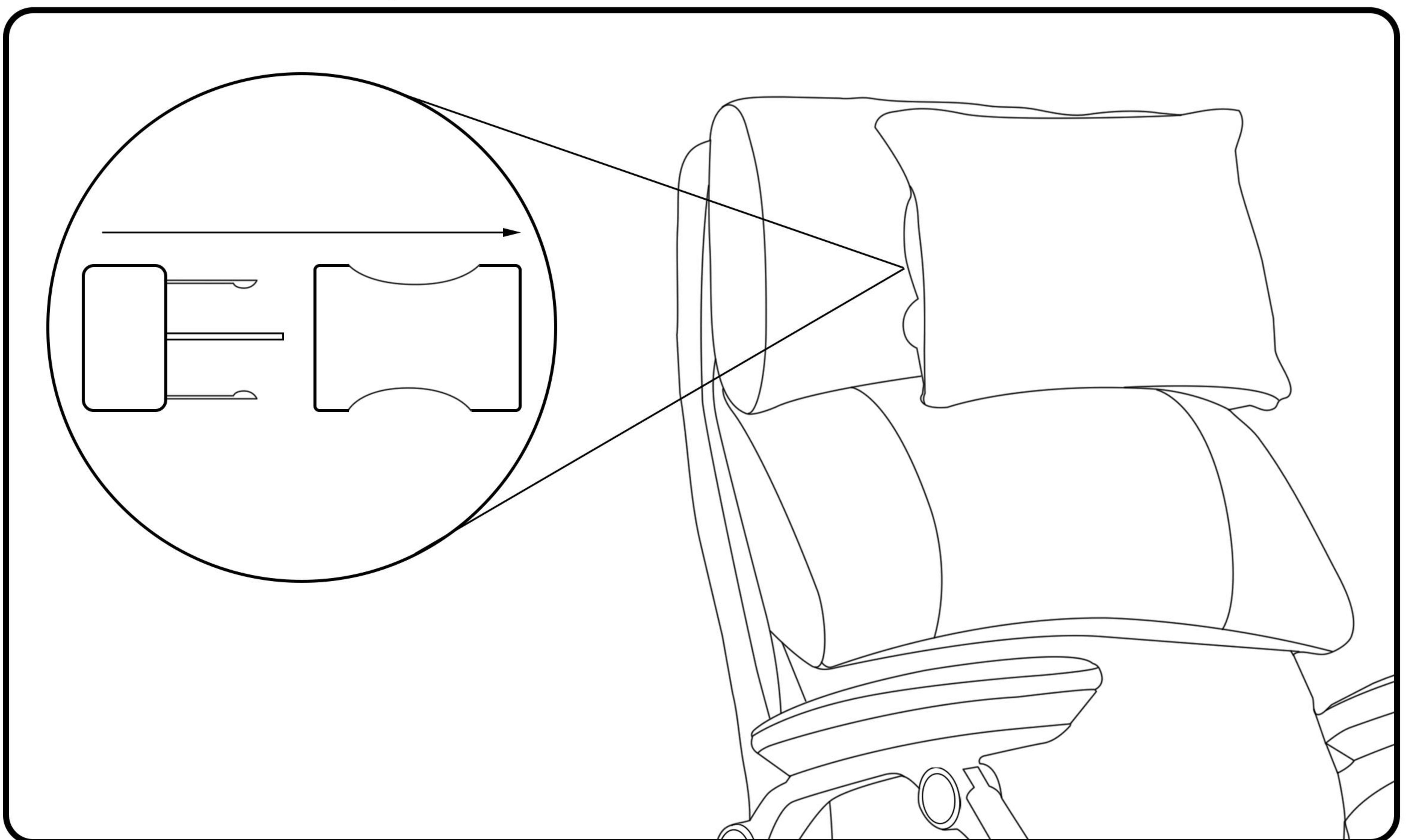

PRE-ASSEMBLY PREPARATION



-Note : Assembly is recommended for two adults. Do not use power tools. Please inspect all items BEFORE assembly. If for any reason you need to return this item, please kindly return it in it's original packaging.

-WARNING!

1. DO NOT let any sharp objects touch or rub the surface of the product.
2. When assembling, do not let children play around the working area.
3. DO NOT USE if this product become damaged, and/or components are broken or missing.

-CARE AND CLEANING: DO NOT scratch or chip the finish. DO NOT use abrasive chemicals for cleaning. Clean with mild soap on a soft rag. Rinse and dry thoroughly.

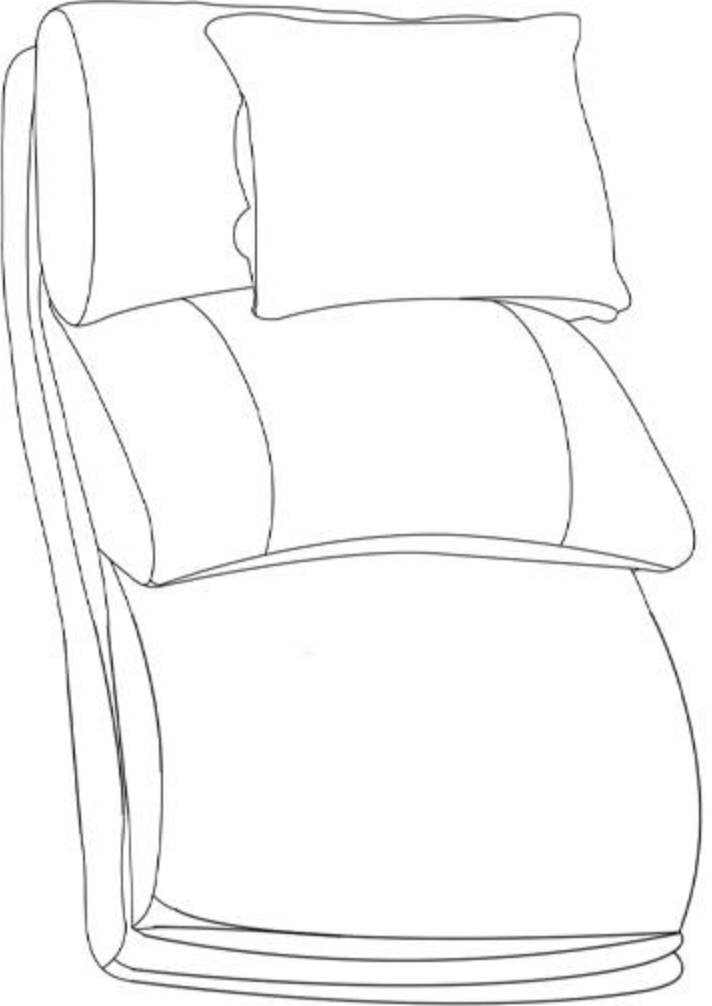
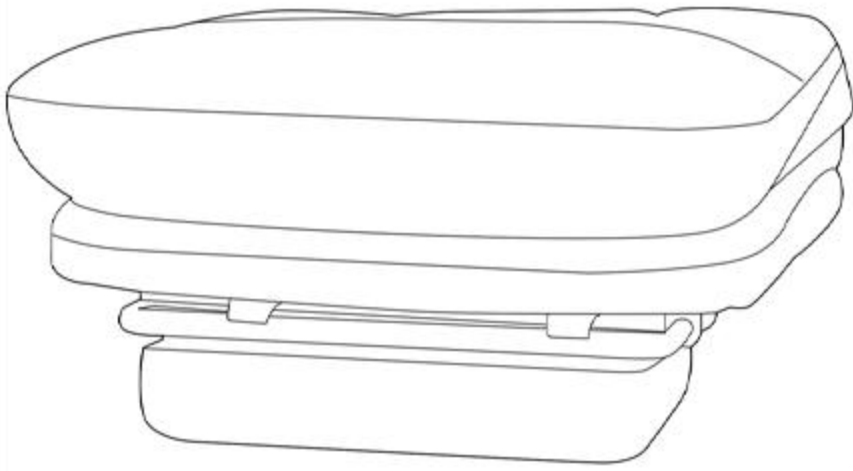
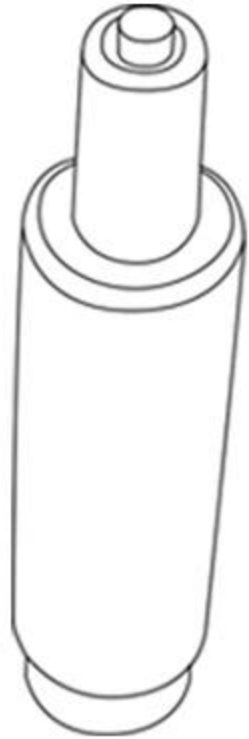
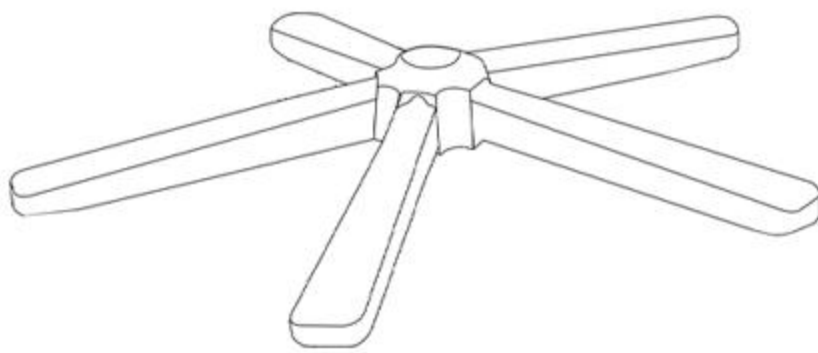
-MAINTENANCE: Please periodically check all fittings and re-tighten as necessary.

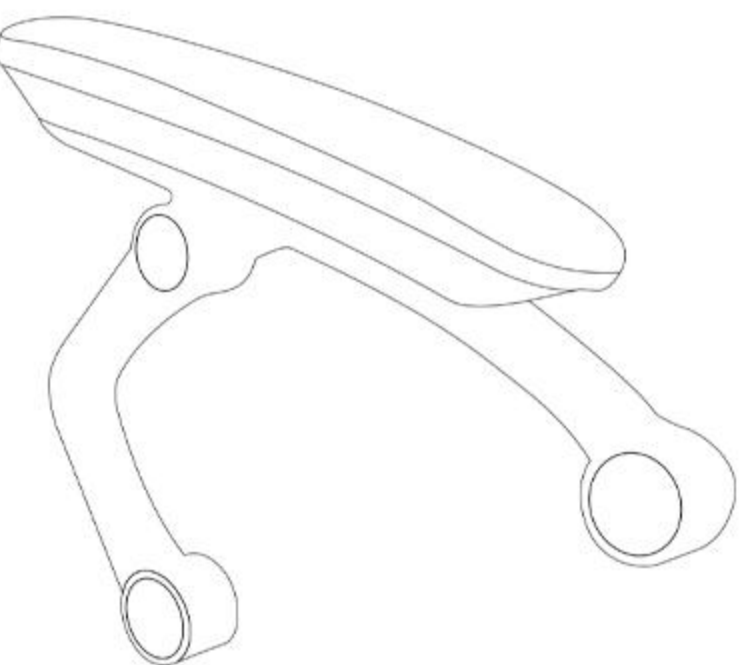
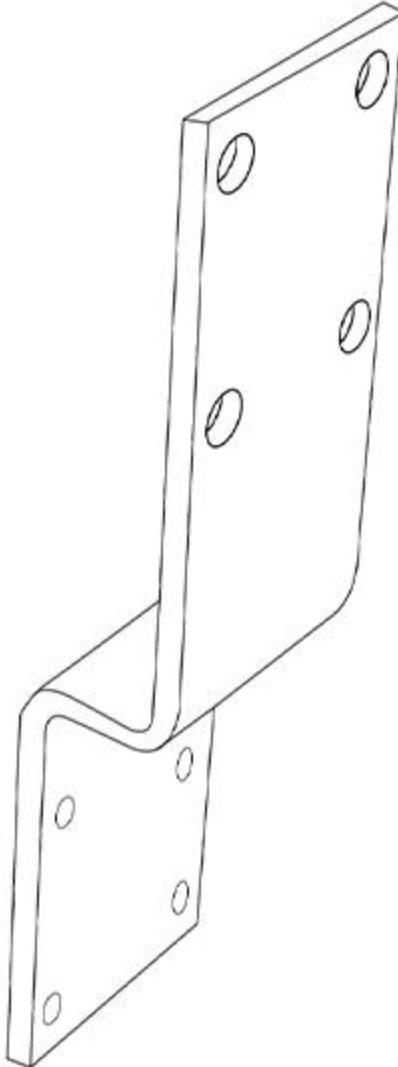
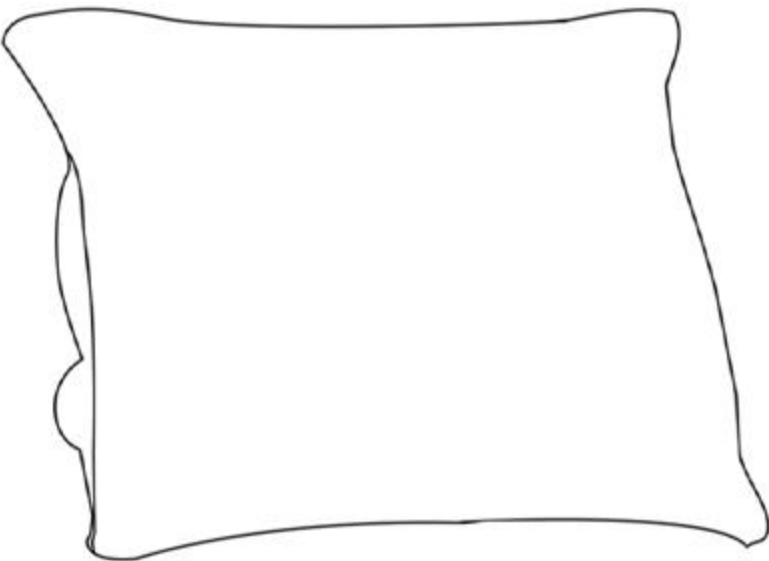
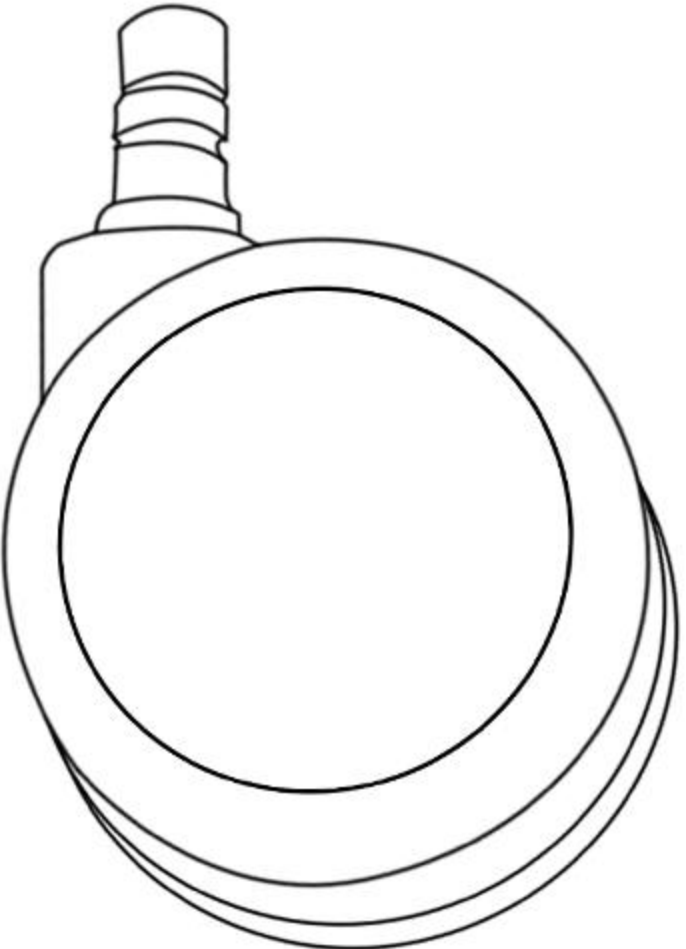
PARTS LIST				
BACKREST 	CUSHION 	GAS STICK 	BIPBD 	WRENCH 
HANDRAIL 	BOLT 	HEADREST 	WHEEL 	SCREW 