

STARY

Assembly Manual 3-person seat CS005

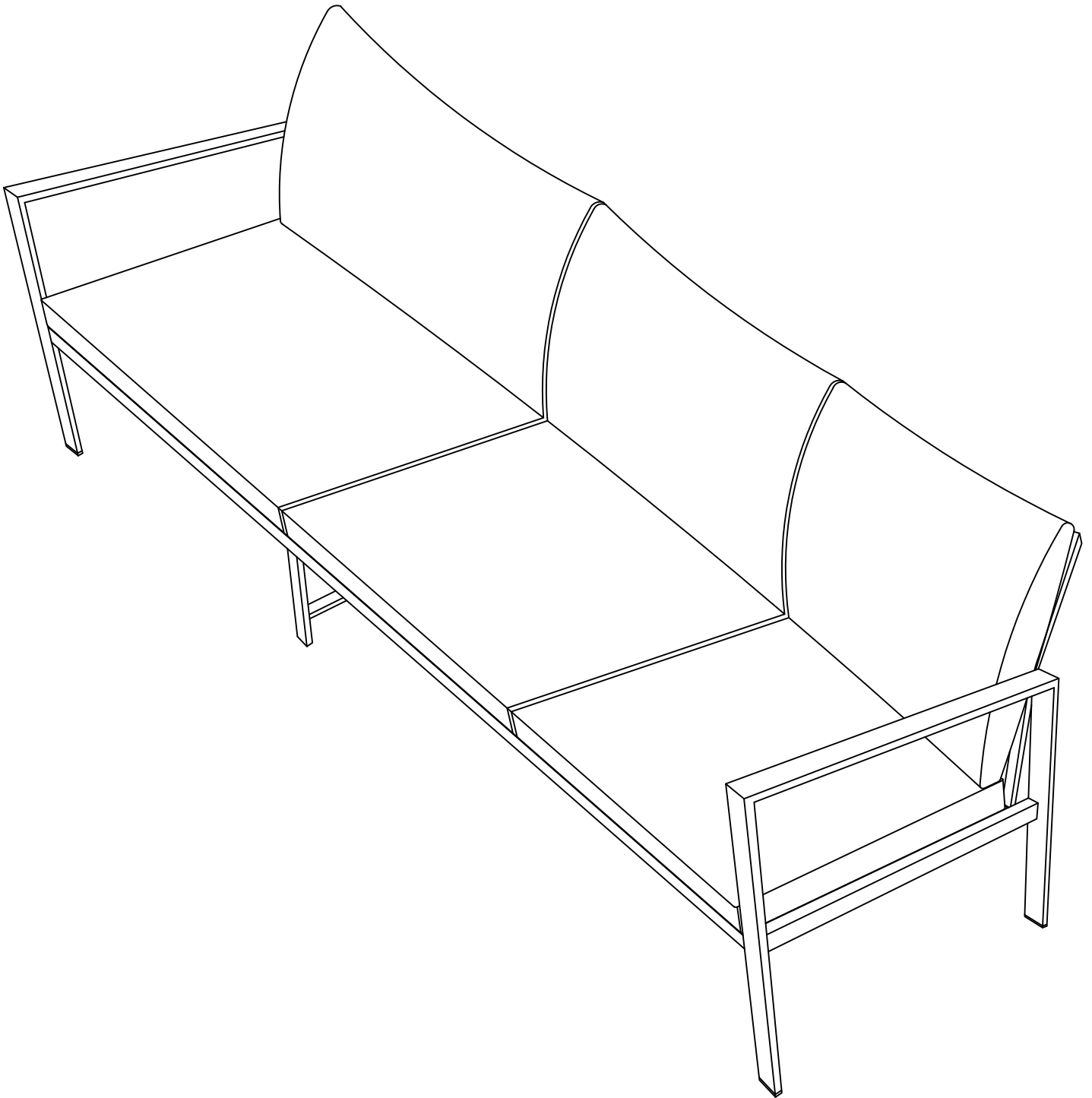

Please read this manual carefully before any operation and keep it properly for future use. If any problems on our product, please feel free to contact us at ecservice@isunon.com.

Exploded View

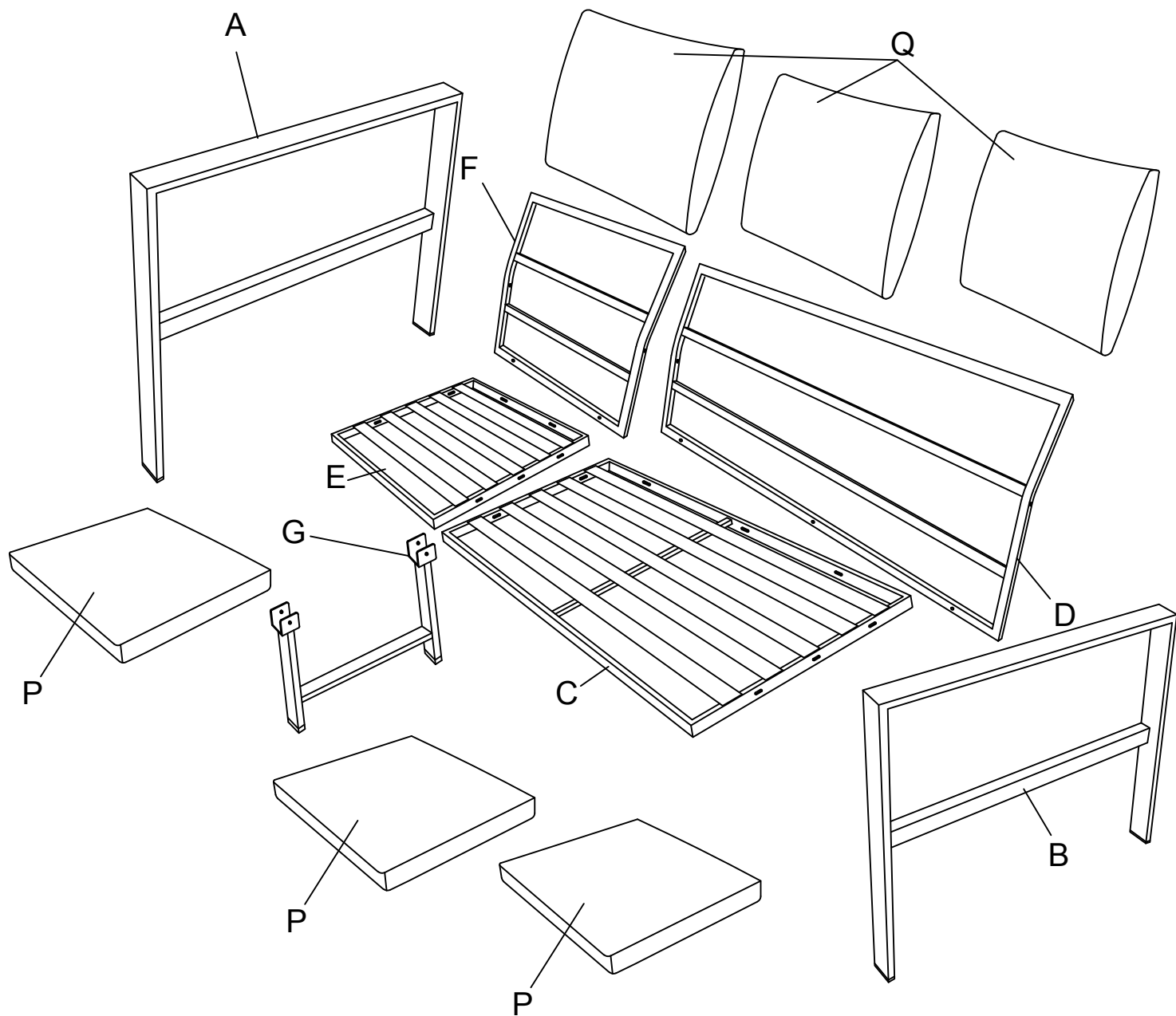

Components List

A

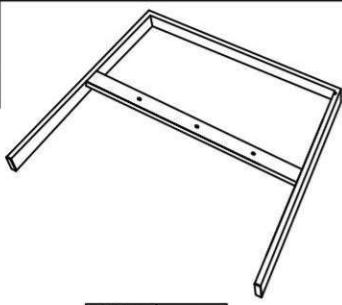

Right Armrest 1PC

B

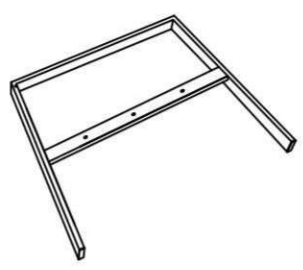

Left Armrest 1PC

C

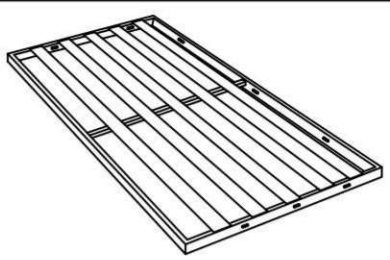

Double Seat 1PC

D

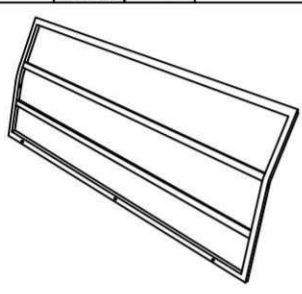

Double Back 1PC

E

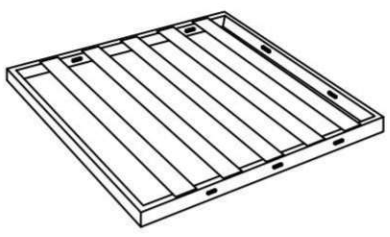

Seat 1PC

F

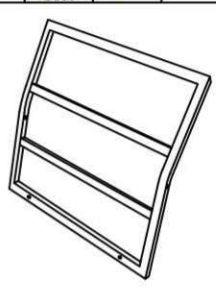

Back 1PC

G

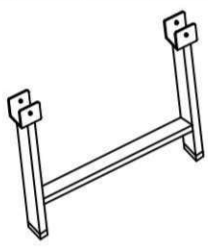

Leg 1PC

H

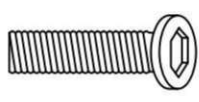

Bolt M6X25 11+2 PCS

I

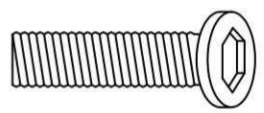

Bolt M6X40 2+1 PCS

J

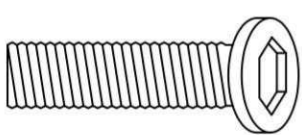

Bolt M6X50 2+1 PCS

K

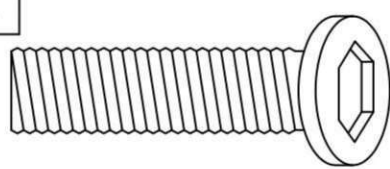

Bolt M6X65 2+1 PCS

L

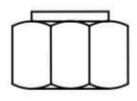

Nut M6 4+1 PCS

M



Washer M6 21+6 PCS

N



Allen wrench M6 1PC

O

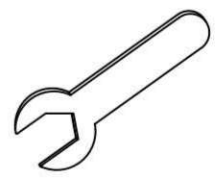

wrench M6 1PC

P

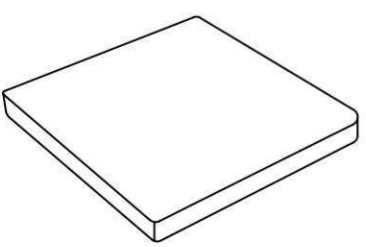

Seat Cushion 3PCS

Q

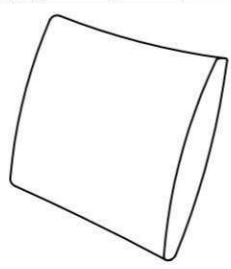



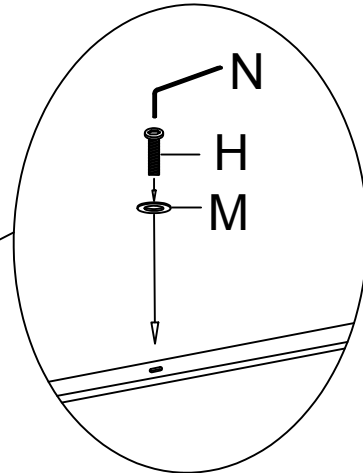
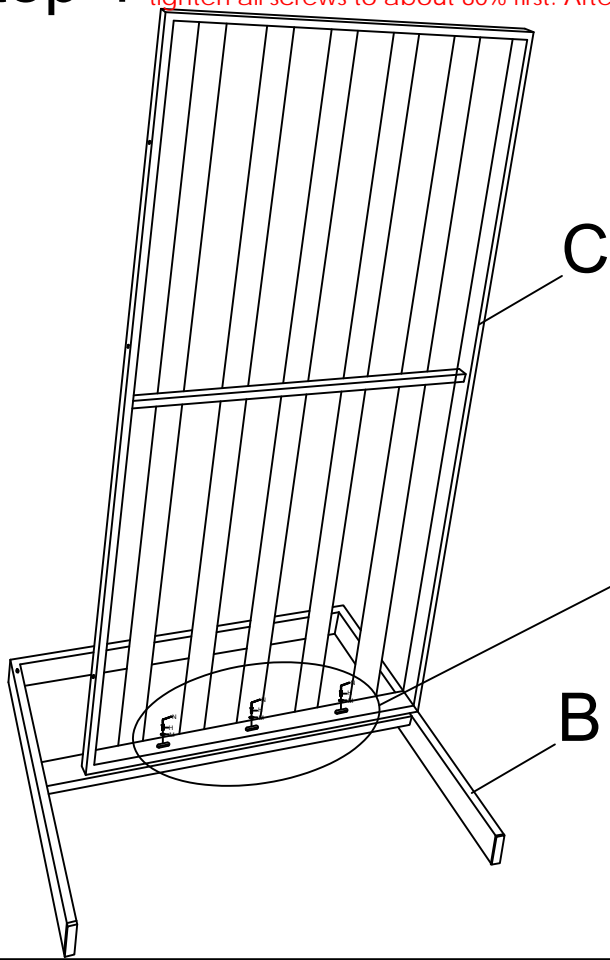

Back Cushion 3PCS

ASSEMBLY INSTRUCTION





Step 1 Attach left armrest(B) to the seat board(C) using washers(M), bolts(H) and Allen wrench(N). **Hand-tighten all screws to about 80% first. After all screws are in place, tighten them fully in sequence**

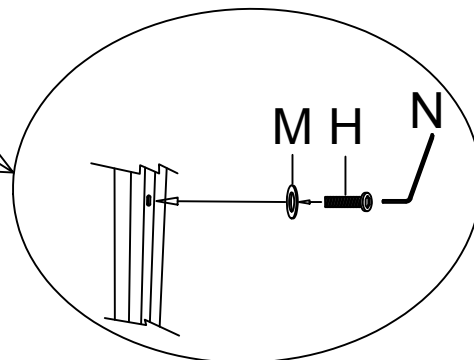
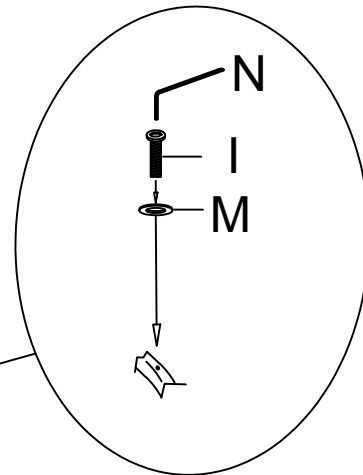
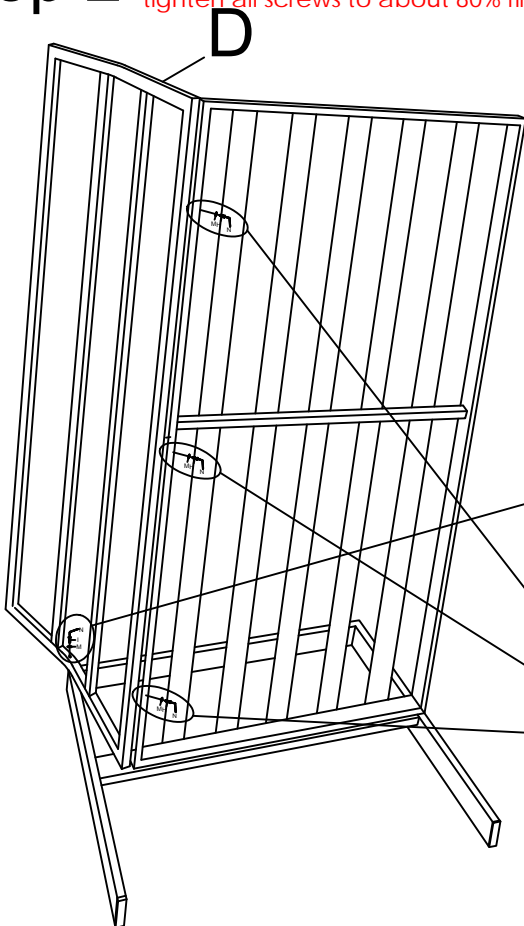

	BX1
	CX1
	HX3
	MX3
	NX1

Step 2 Attach back frame(D) to the seat frame using washers(M), bolts(H&I), and Allen wrench(N). **Hand-tighten all screws to about 80% first. After all screws are in place, tighten them fully in sequence**



	DX1
	HX3
	IX1
	MX4
	NX1

ASSEMBLY INSTRUCTION

Step 3

Attach back frame(F) to the seat frame(E) using washers(M), bolts(H), and Allen wrench(N). Attach single seat to the love seat frame using nuts(L), washers(M), bolts(K), and Allen wrench(N&O). Attach middle leg(G) to the seat frame using nuts(L), washers(M), bolts(J), and Allen wrench(N&O). **Hand-tighten all screws to about 80% first. After all screws are in place, tighten them fully in sequence**

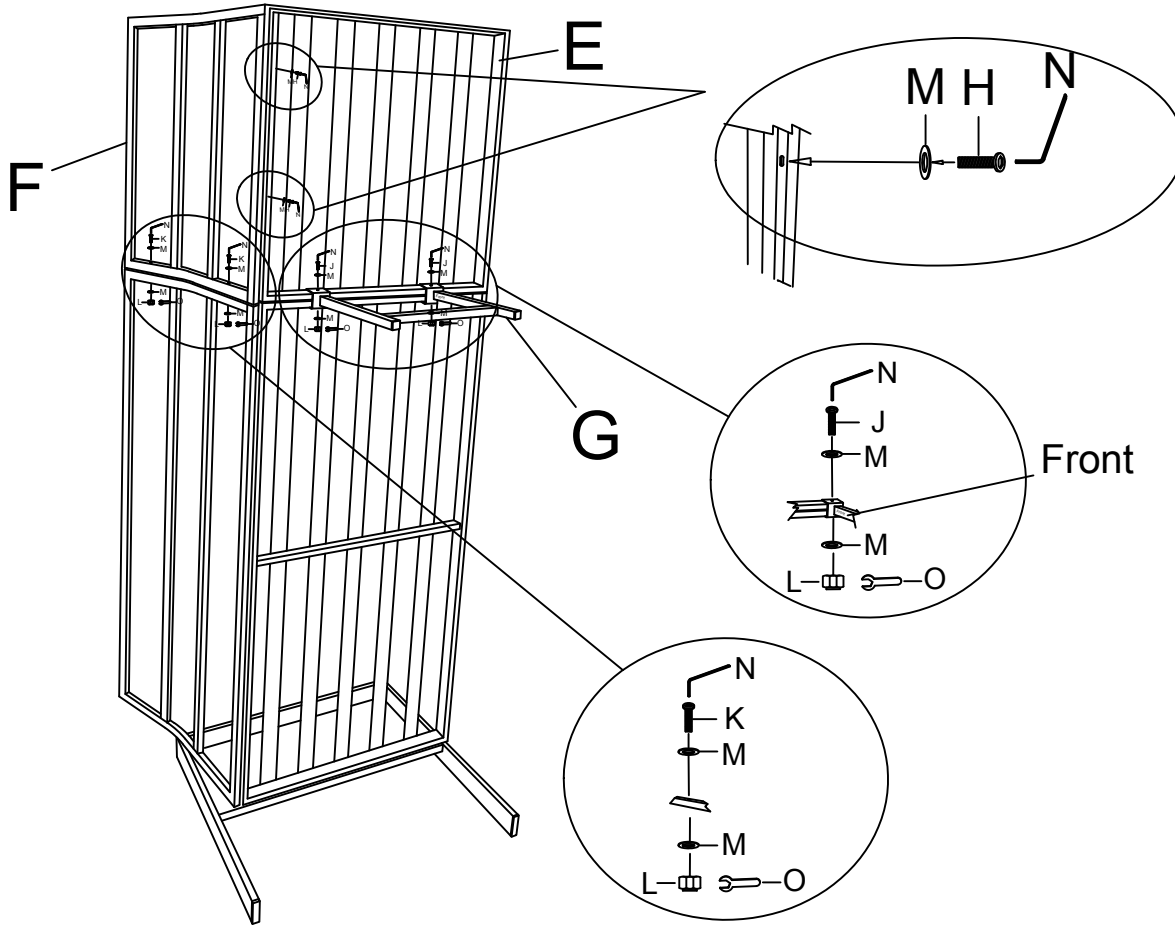

	EX1
	FX1
	GX1
	HX2
	JX2
	KX2
	MX10
	LX4
	NX1
	OX1

Step 4

Attach right armrest(A) to the seat board(C) using washers(M), bolts(H&I) and Allen wrench(N). **Hand-tighten all screws to about 80% first. After all screws are in place, tighten them fully in sequence**

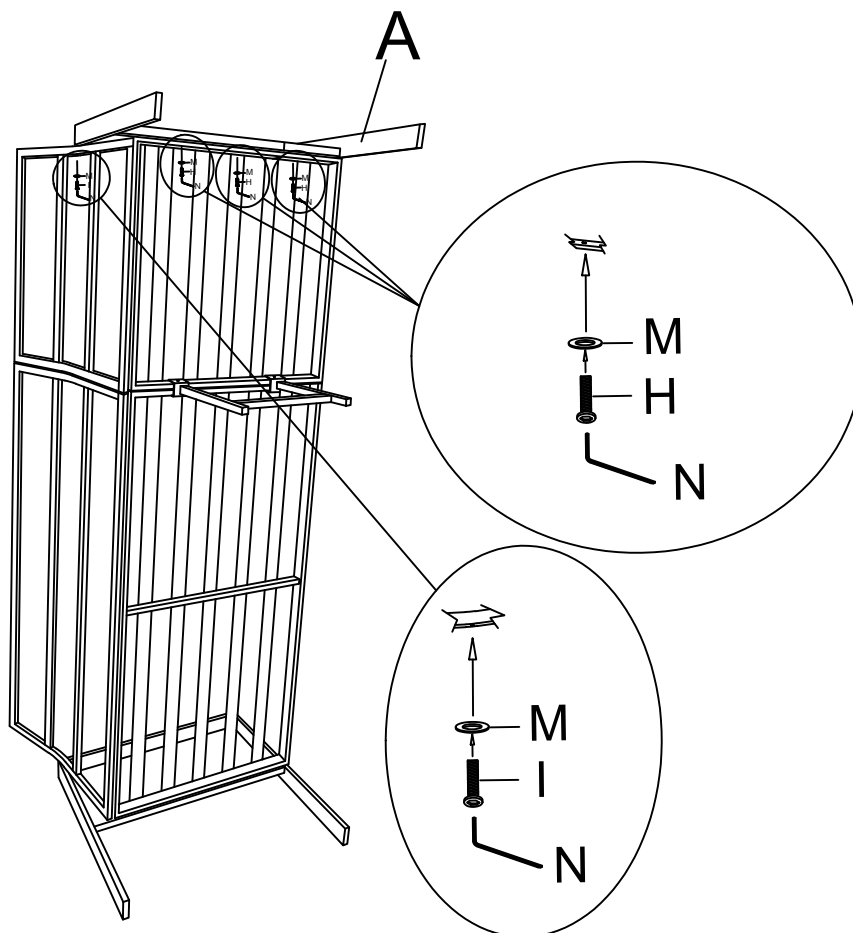

	AX1
	HX3
	IX1
	MX4
	NX1

ASSEMBLY INSTRUCTION

Step 5

Tighten all bolts 100%, and flip the seat over. Put the seat cushion(P) and back cushion(Q) on the seat frame. The assembly is done.

