

NOTICE

* Please make sure that you have all parts indicated and they are in good condition before you begin assembly of this item. Refer to part list and hardware list below for guidance.

* This item should be assembled on a soft surface to prevent scratching the finish during assembly.

* This item may require periodic tightening.

* If you are having difficulty, our friendly Customer Care team is always here to help.

PREPARATION

* Before beginning assembly of product, make sure all parts are present. Compare parts with part contents list and hardware contents list.

* If any part is missing or damaged, do not attempt to assemble the product

* Estimated assembly time : **20 minutes.**

* Tools required for assembly (included) : **Allen key**













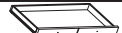



* Tools required for assembly (not included) : **Philip screw driver**

* Tools required for assembly (not included) : **Mallet**

CARE AND MAINTENANCE

Always use felt pads under all articles to prevent discoloration or softening of the lacquer. Plastic and rubber bases on items can discolor wood. Wipe up spill immediately and avoid common hazards such as hot dishes, harsh solvents and abrasives. Cleaning should be done with a soft lint free cotton cloth dampened with water or furniture polish.

Part List and Hardware List

PIECE	DESCRIPTION	PICTURE	QUANTITY
A	Top Panel		1x
B	Leg Frame L		1x
C	Leg Frame R		1x
D	Drawer Unit		1x
E	Handle Bar		1x
F	Shelf Panel		2x
G	Apron		4x
HW 1	Jcbc Bolt M6x0.5x40mm		2x
HW 2	Jcbc Bolt M6x0.5x60mm		12x
HW 3	Barrel Nut		10x
HW 4	Silver Metal Knob		2x
HW 5	Truss Screw 20mm		2x
HW 6	Wood Button		12x
HW 7	Caster Wheel		4x
HW 8	Wood Dowel M8 x 30mm		8x
HW 9	Allen Key M4		1x
HW 10	Spanner 13		1x

Product Dimensions : 38.97" W x 17.71" D x 36.22" H



Weight capacity - 55LBS
Warning : Do not stand on trolley.
Warning : Do not over torque bolts.

PREPARATION

- * Before beginning assembly of product, make sure all parts are present. Compare parts with part contents list and hardware contents list.
- * If any part is missing or damaged, do not attempt to assemble the product.
- * Estimated assembly time : 20 minutes
- * Tools required for assembly (included) : Allen key
- * Tools required for assembly (not included) : Philip screw driver
- * Tools required for assembly (not included) : Mallet
- * If you are having difficulty, our friendly Customer Care team is always here to help.

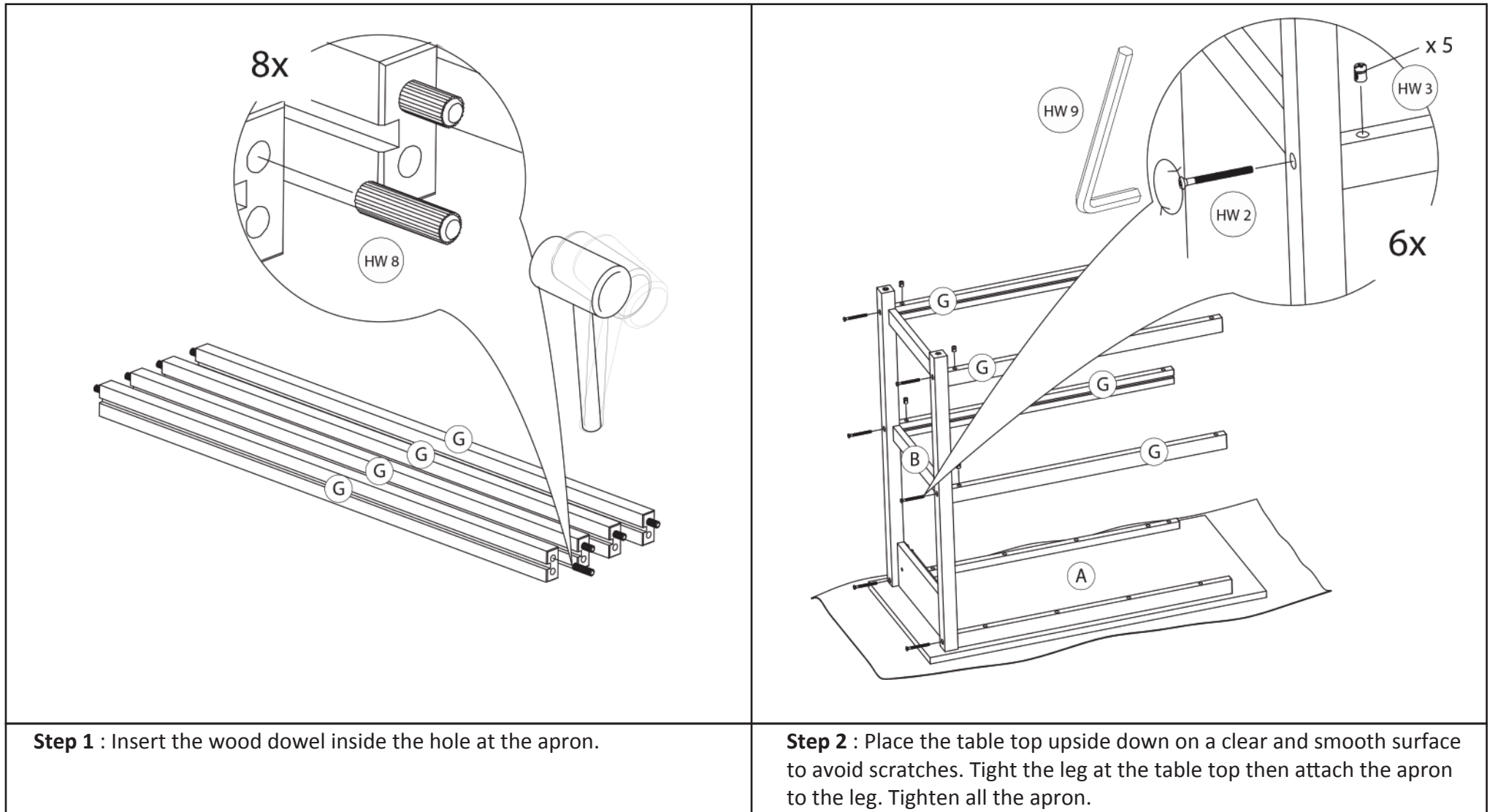

Step 1 : Insert the wood dowel inside the hole at the apron.

Step 2 : Place the table top upside down on a clear and smooth surface to avoid scratches. Tight the leg at the table top then attach the apron to the leg. Tighten all the apron.

PREPARATION

- * Before beginning assembly of product, make sure all parts are present. Compare parts with part contents list and hardware contents list.
- * If any part is missing or damaged, do not attempt to assemble the product.
- * Estimated assembly time : 20 minutes
- * Tools required for assembly (included) : Allen key
- * Tools required for assembly (not included) : Philip screw driver
- * Tools required for assembly (not included) : Mallet
- * If you are having difficulty, our friendly Customer Care team is always here to help.

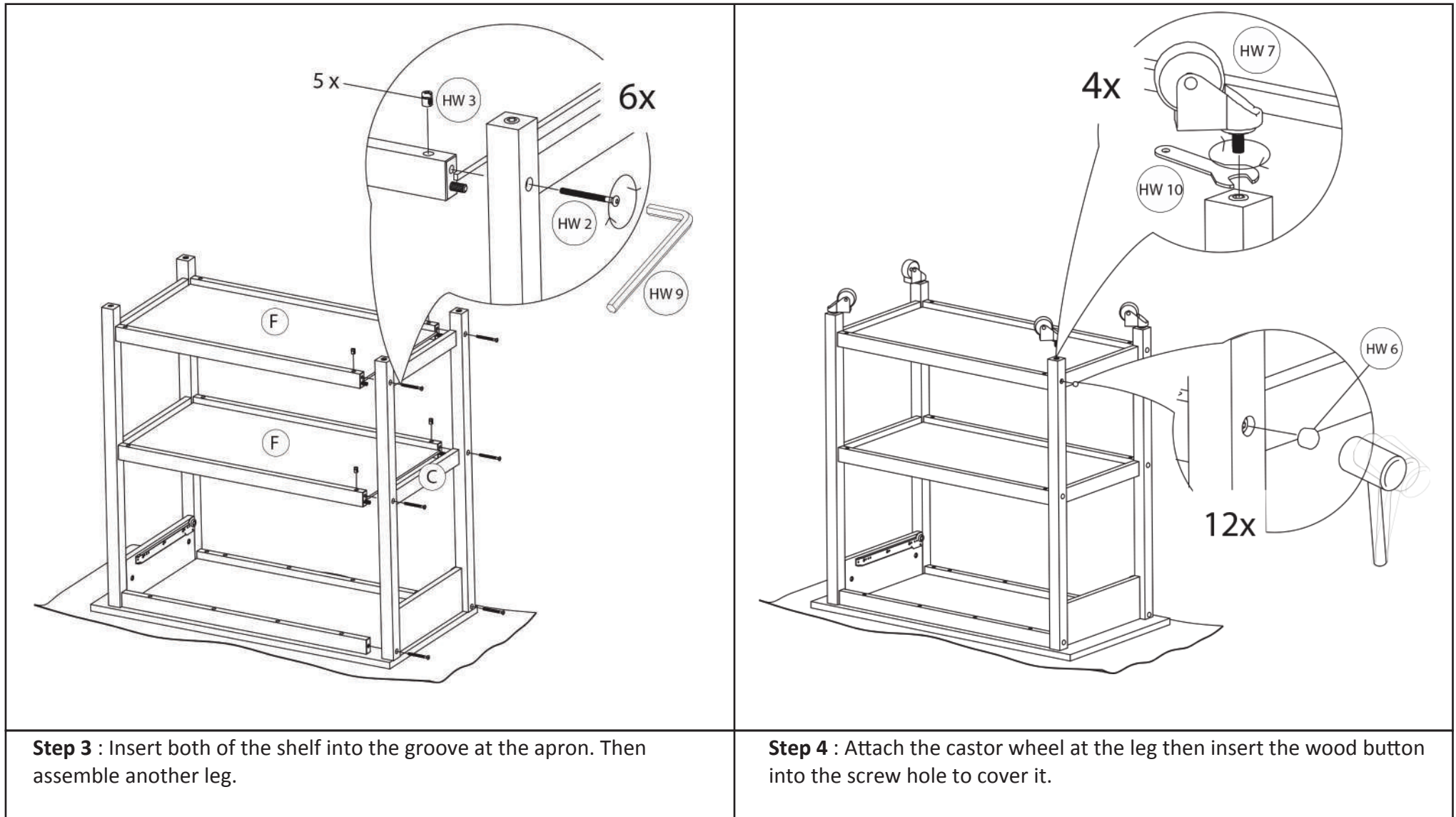

Step 3 : Insert both of the shelf into the groove at the apron. Then assemble another leg.

Step 4 : Attach the castor wheel at the leg then insert the wood button into the screw hole to cover it.

PREPARATION

- * Before beginning assembly of product, make sure all parts are present. Compare parts with part contents list and hardware contents list.
- * If any part is missing or damaged, do not attempt to assemble the product.
- * Estimated assembly time : 20 minutes
- * Tools required for assembly (included) : Allen key
- * Tools required for assembly (not included) : Philip screw driver
- * Tools required for assembly (not included) : Mallet
- * If you are having difficulty, our friendly Customer Care team is always here to help.

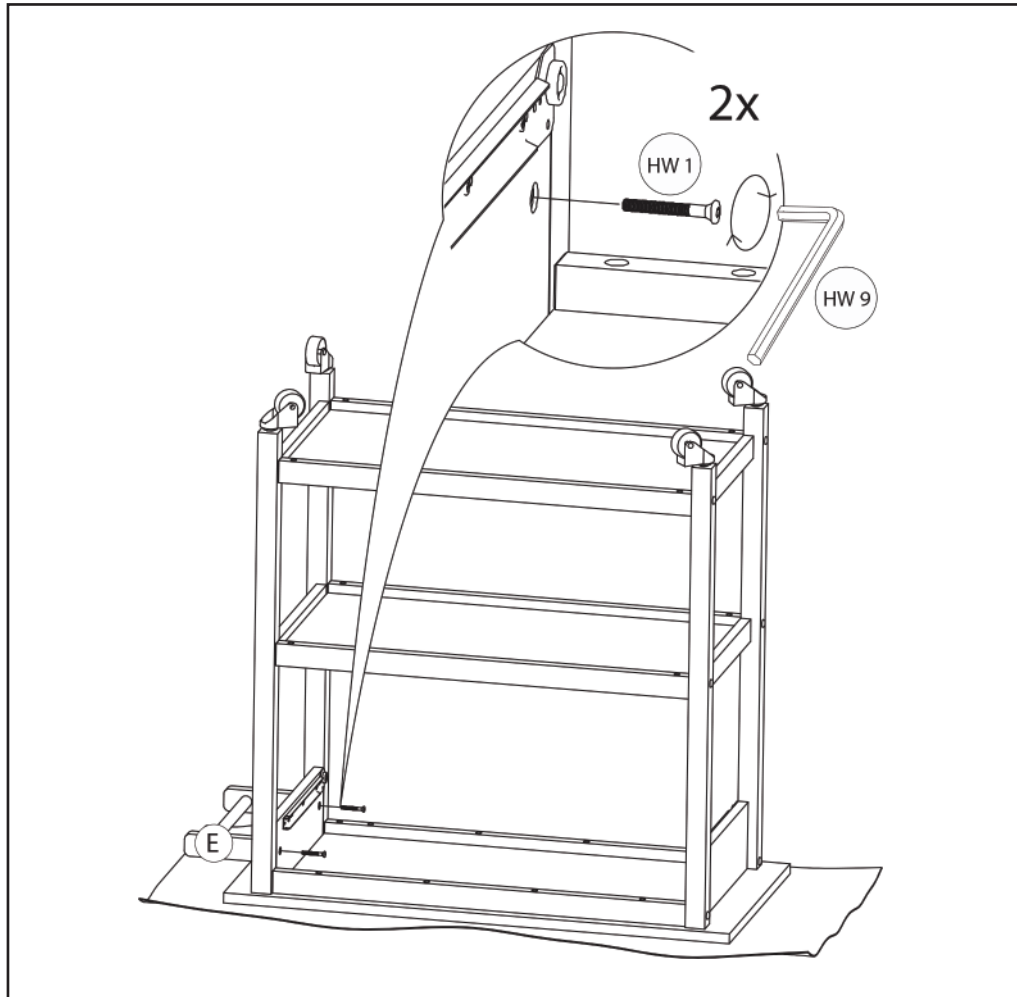

Step 5 : Assemble the handle bar.



Step 6 : Attach the silver metal knob, then insert the drawer unit through the slider rail.