

## Recommended Maximum Weight

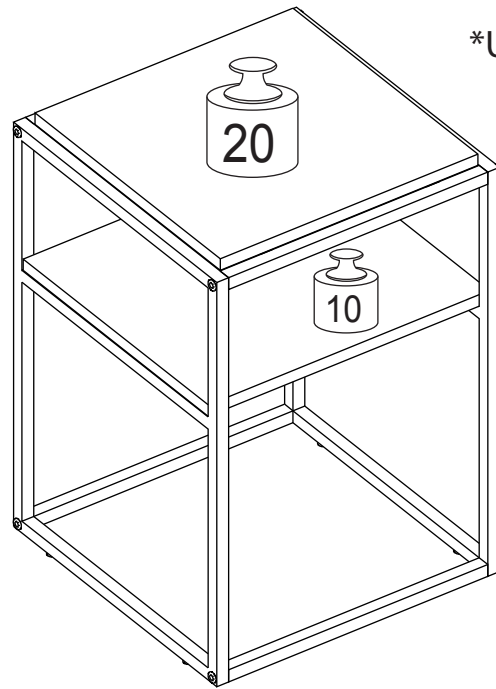

\*Unit in Pound(lbs)



**WARNING:**

>This unit has been designed to support the maximum loads shown. Exceeding these load limits could cause sagging, instability, product collapse, and/or serious injury.

>DO NOT allow children to climb on unit.

## STACK UP FUNCTION

**STEP (a)**  
Slightly loosen the Screw(A)  
using Allen Key(D), as shown.

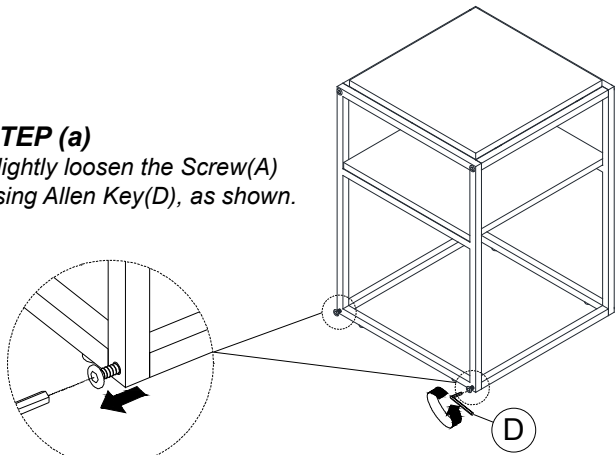

**STEP (b)**  
Combine both assembled  
unit and tighten the Screw(A)  
using Allen Key(D), as shown.

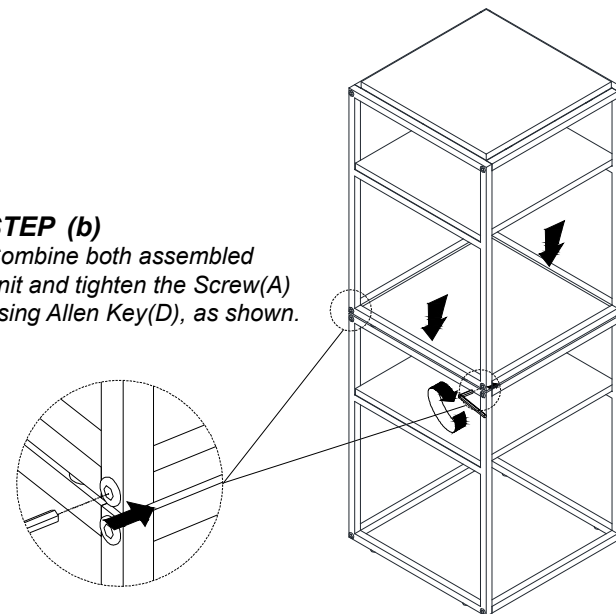

## PLEASE FOLLOW BELOW INSTRUCTION TO PREVENT PRODUCT TIP OVER.

HARDWARE LIST			QTY
WALL PLUG	EYELET SCREW	CABLE TIE	2 Sets
1/4" DRILL BIT	WALL PLUG	EYELET SCREW	

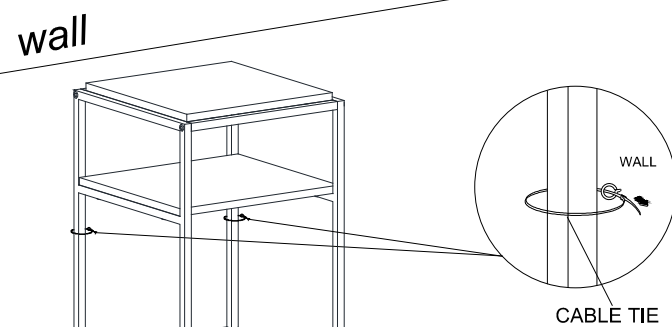

**00:15**

Approx. 15 minutes



Recomm. 1 Person







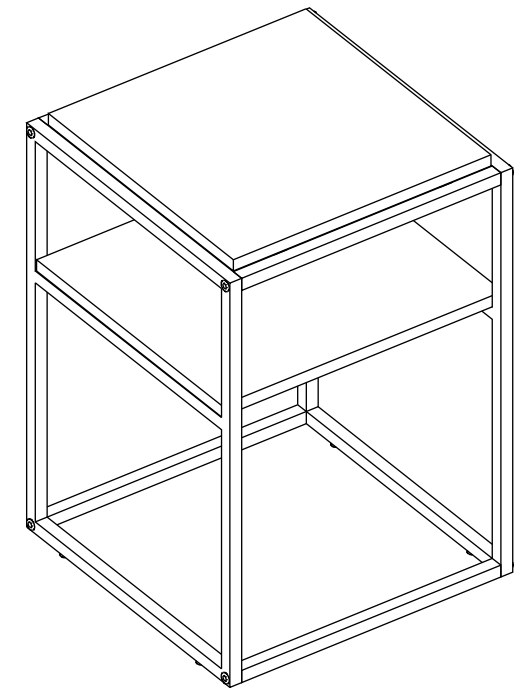

## Assembly Instruction

Stackable Shelf , 2-Tier



# HARDWARE & PARTS LIST

NO	HARDWARE LIST	QTY
A	LONG SCREW 	8pcs
B	SHORT SCREW 	4pcs
C	MIDDLE SCREW 	4pcs
D	ALLEN KEY 	1pc
E	RUBBER STUD 	4pcs

NO	PARTS LIST	QTY
1	METAL FRAME 	2pcs
2	UPPER RAIL 	2pcs
3	BOTTOM RAIL 	2pcs
4	TOP PANEL 	1pc
5	SHELF PANEL 	1pc

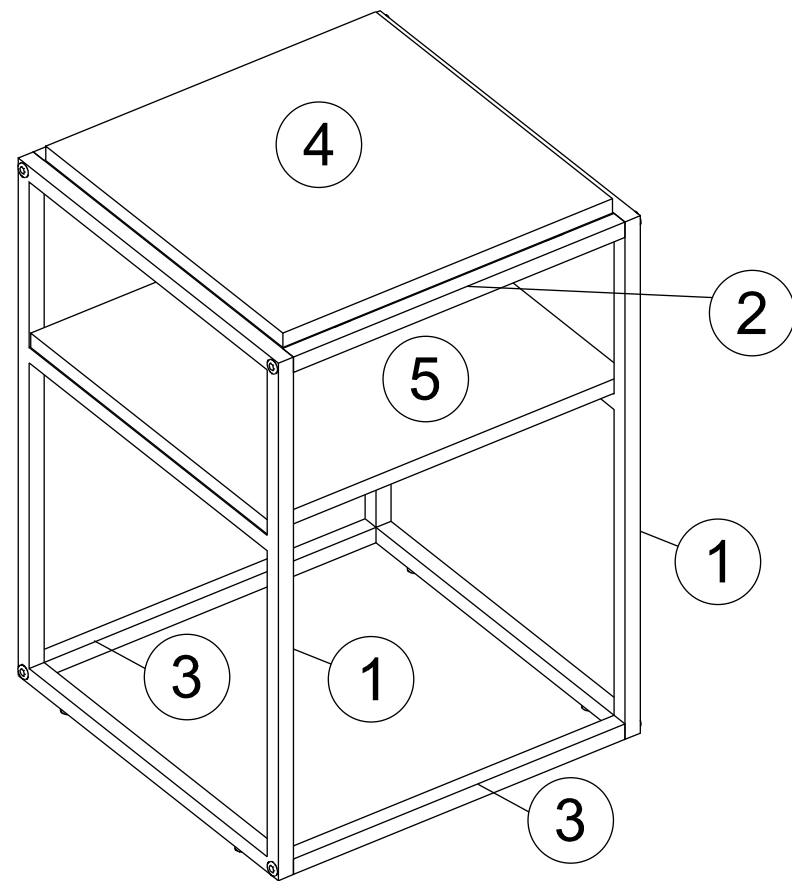

### USEFUL HINTS BEFORE YOU START:

1. Read each step carefully before assembling.
2. It is important that each step is performed in correct order to avoid difficulties.
3. Identify, sort and count the parts before assembly.
4. Assemble your furniture on packaging cardboard to prevent scratch or damage.
5. Clean the product with mild cleanser using soft dampened cloth. Do not use harsh or abrasive cleanser.
6. Using incompatible hardware might cause damage to product.

# ASSEMBLY INSTRUCTIONS

BEFORE YOU BEGIN, PLEASE READ ASSEMBLY INSTRUCTION CAREFULLY, FOLLOW THEM STEP BY STEP.

REMINDER: Please do not fully tighten any screw until all of them are in right positions.

