

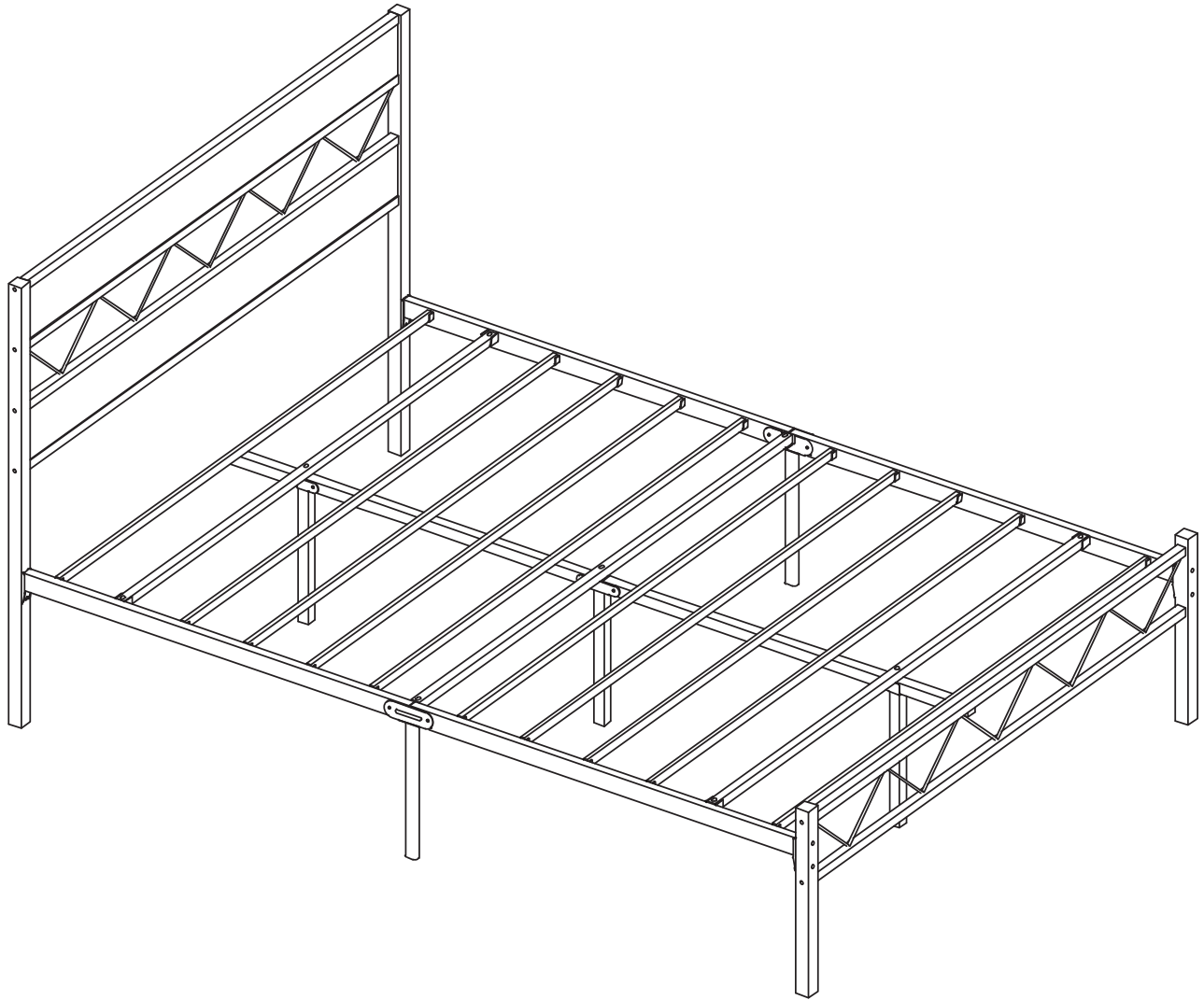

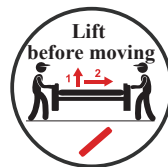

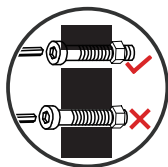

Installation & Assembly



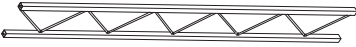
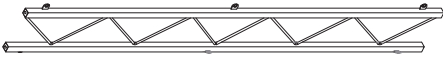

Bed Frame

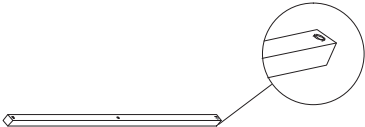
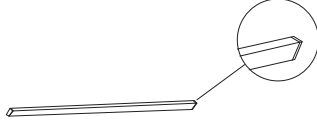

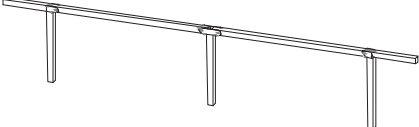
CAUTION!

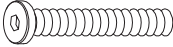
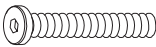

<p>1</p>		<p>2</p>	<p>2</p>		<p>2</p>
<p>3</p>		<p>1</p>	<p>4</p>		<p>1</p>
<p>5</p>		<p>2</p>	<p>6</p>		<p>2</p>
<p>7</p>	 <ul style="list-style-type: none"> ● With Screw Holes ★ Mit Schraubenlöchern ▲ Avec trous de vis 	<p>3</p>	<p>8</p>	 <ul style="list-style-type: none"> ● Without Screw Holes ★ Ohne Schraubenlöcher ▲ Sans trous de vis 	<p>10</p>
<p>9a</p>		<p>2</p>	<p>10</p>		<p>1</p>

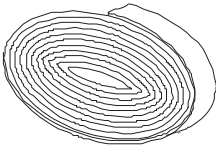
<p>A</p>	 <p>M8×45mm</p>	<p>8</p>	<p>B</p>	 <p>M6×50mm</p>	<p>12</p>
<p>C</p>	 <p>M6×28mm</p>	<p>6</p>	<p>D</p>	 <p>M8</p>	<p>4</p>
<p>E</p>	 <p>φ8.5mm</p>	<p>20</p>	<p>F</p>	 <p>M13/M10</p>	<p>1</p>
<p>G</p>	 <p>5mm</p>	<p>1</p>	<p>H</p>	 <p>M6×12mm</p>	<p>12</p>
<p>N</p>		<p>1</p>	<p>K</p>	 <p>M6×55mm</p>	<p>3</p>

Step 1

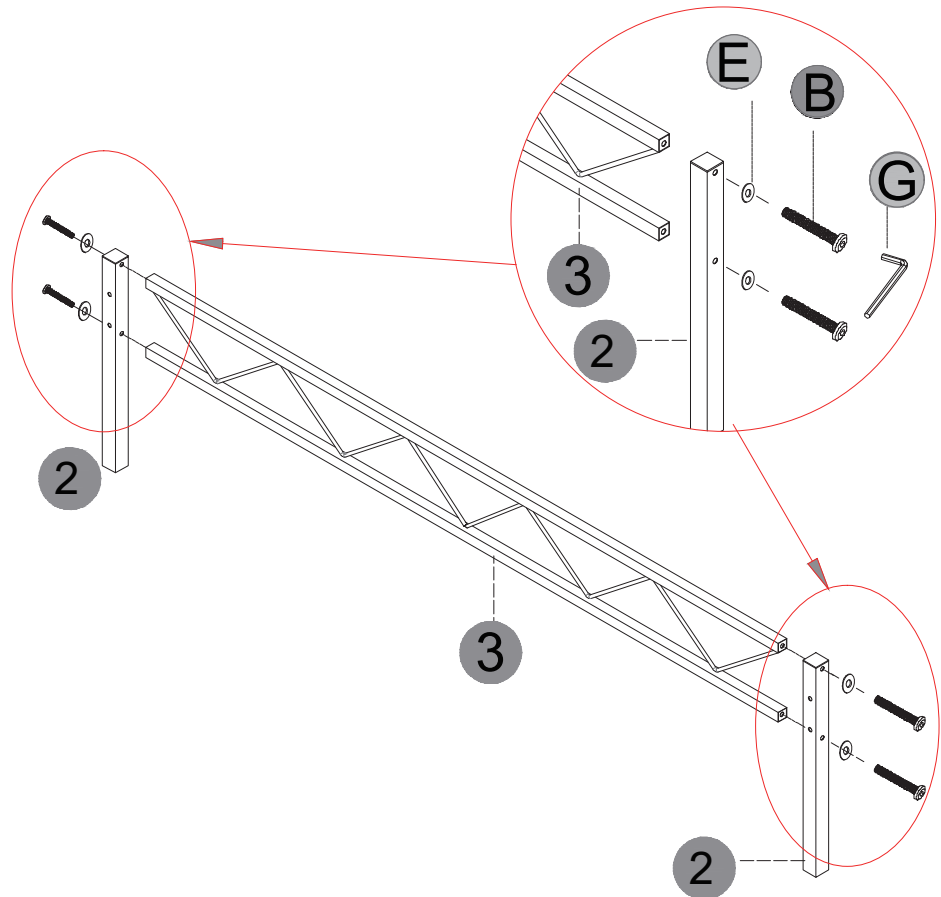

● Note: For easy setup, do not tighten screws during the installation process.

★ Hinweis: Um die Installation zu erleichtern, ziehen Sie die Schrauben während des Installationsprozesses nicht vollständig fest.

▲ Remarque : Pour faciliter le montage, ne serrez pas les vis à fond pendant l'installation.

Step 2

	Bx8		Ex8		Gx1
---	-----	--	-----	--	-----

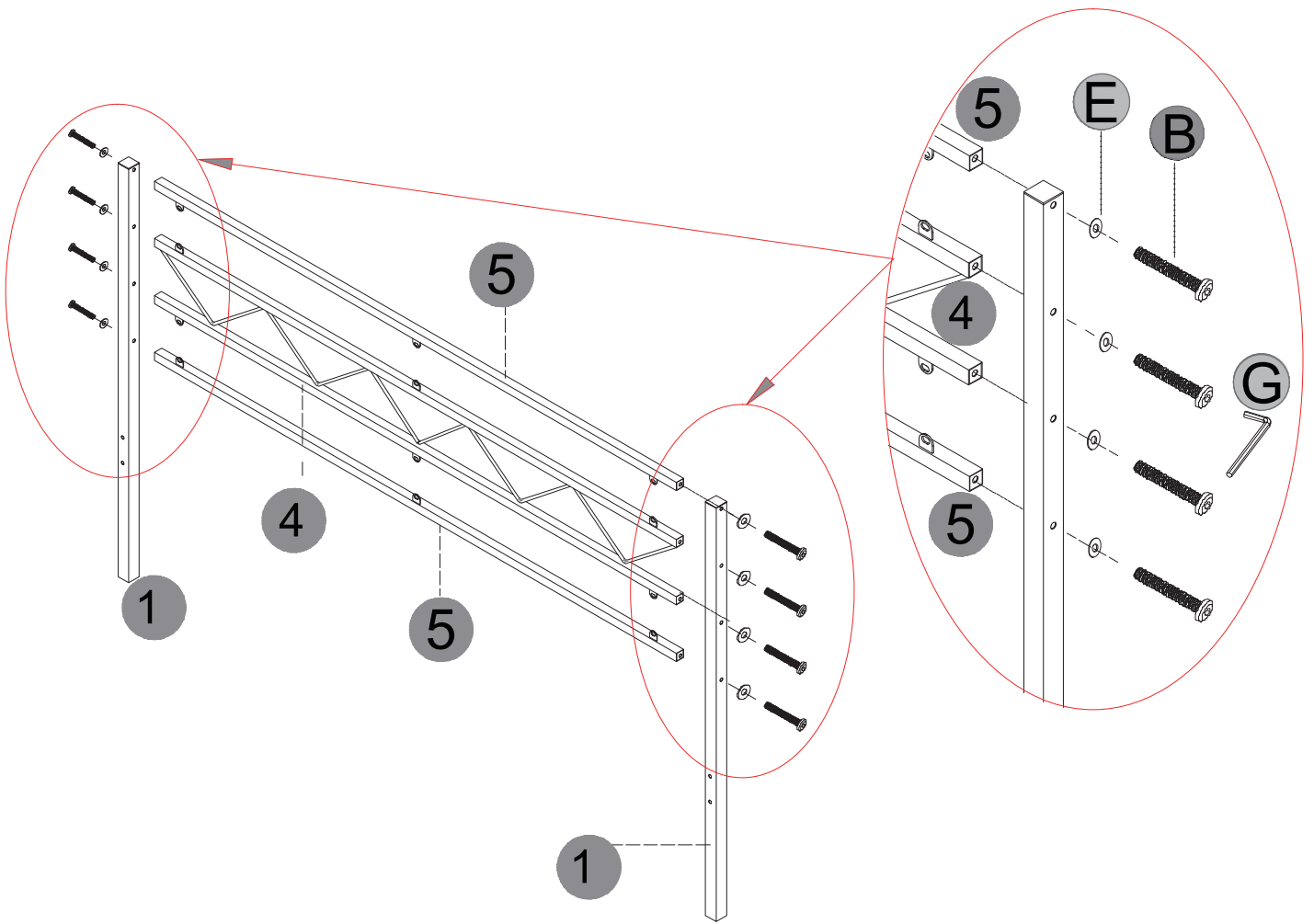

Step 3







Hx12

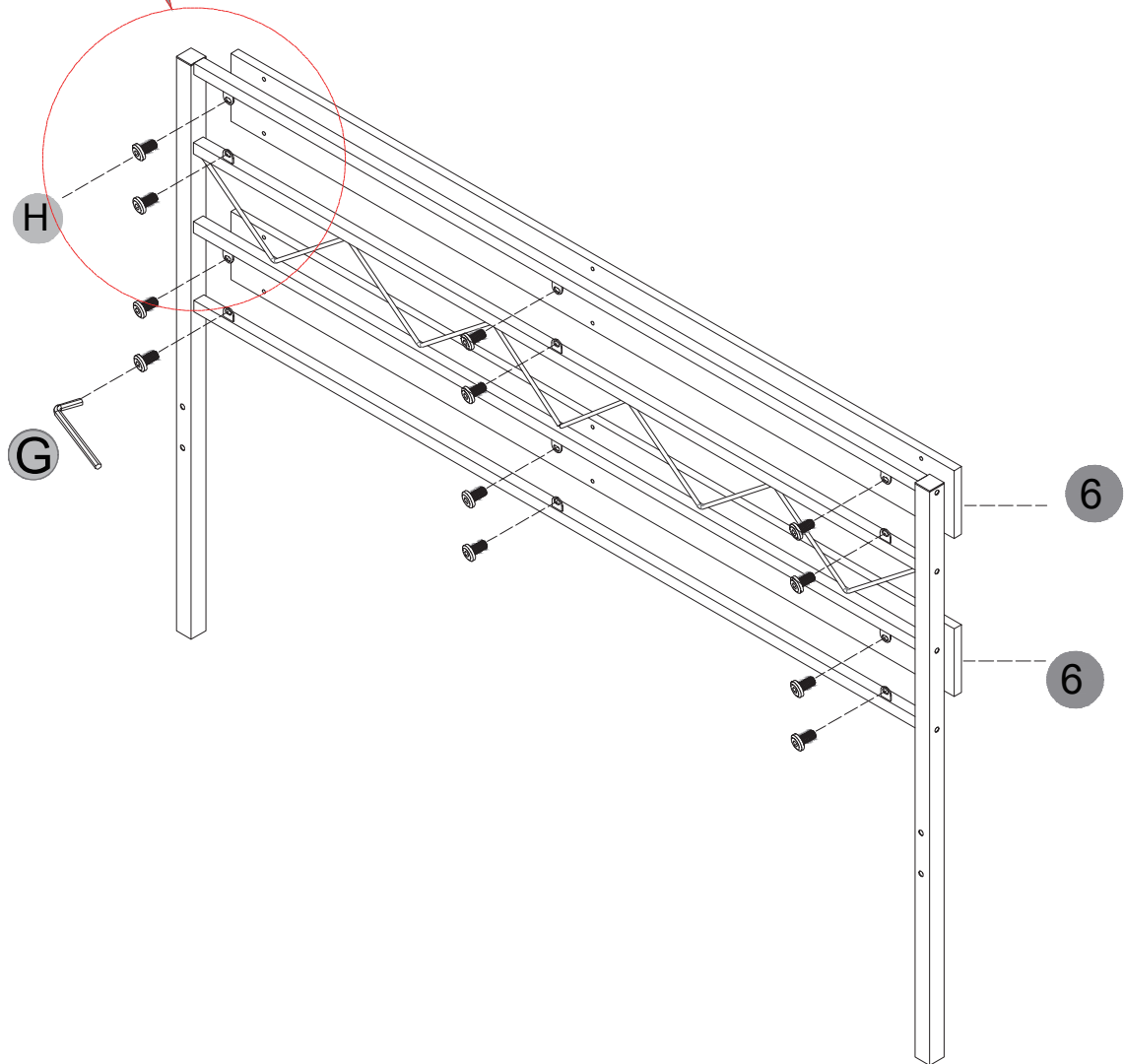
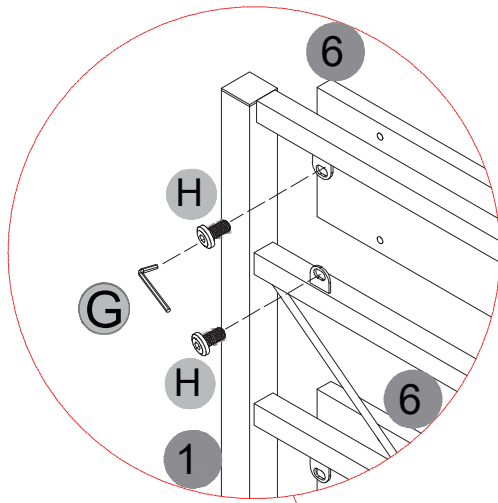

Gx1



Step 4

	Ax8		Dx4		Ex8
	Fx1		Gx1		

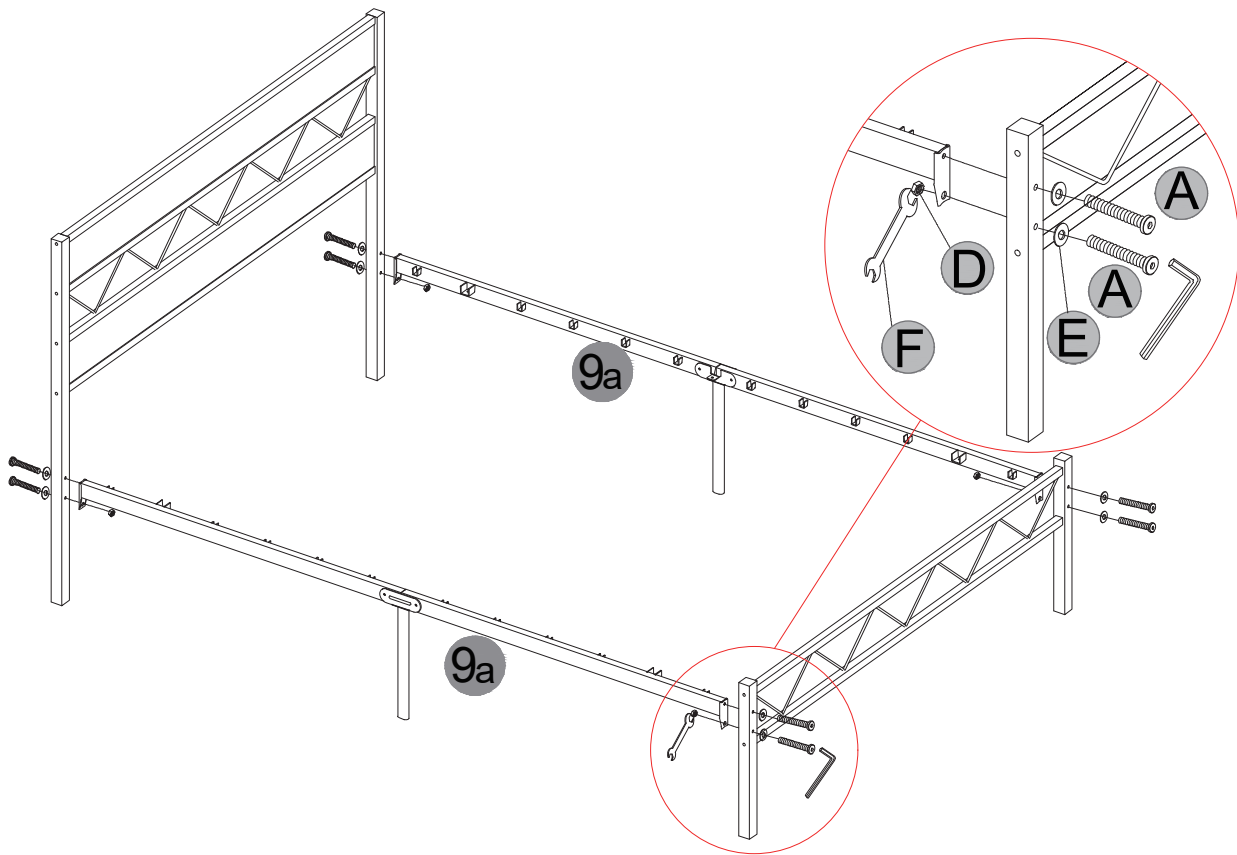
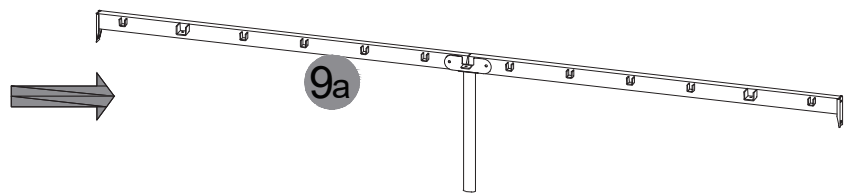
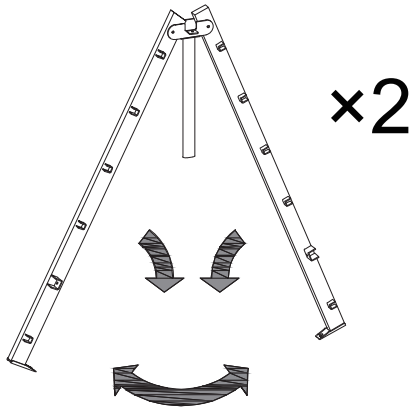

Step 5

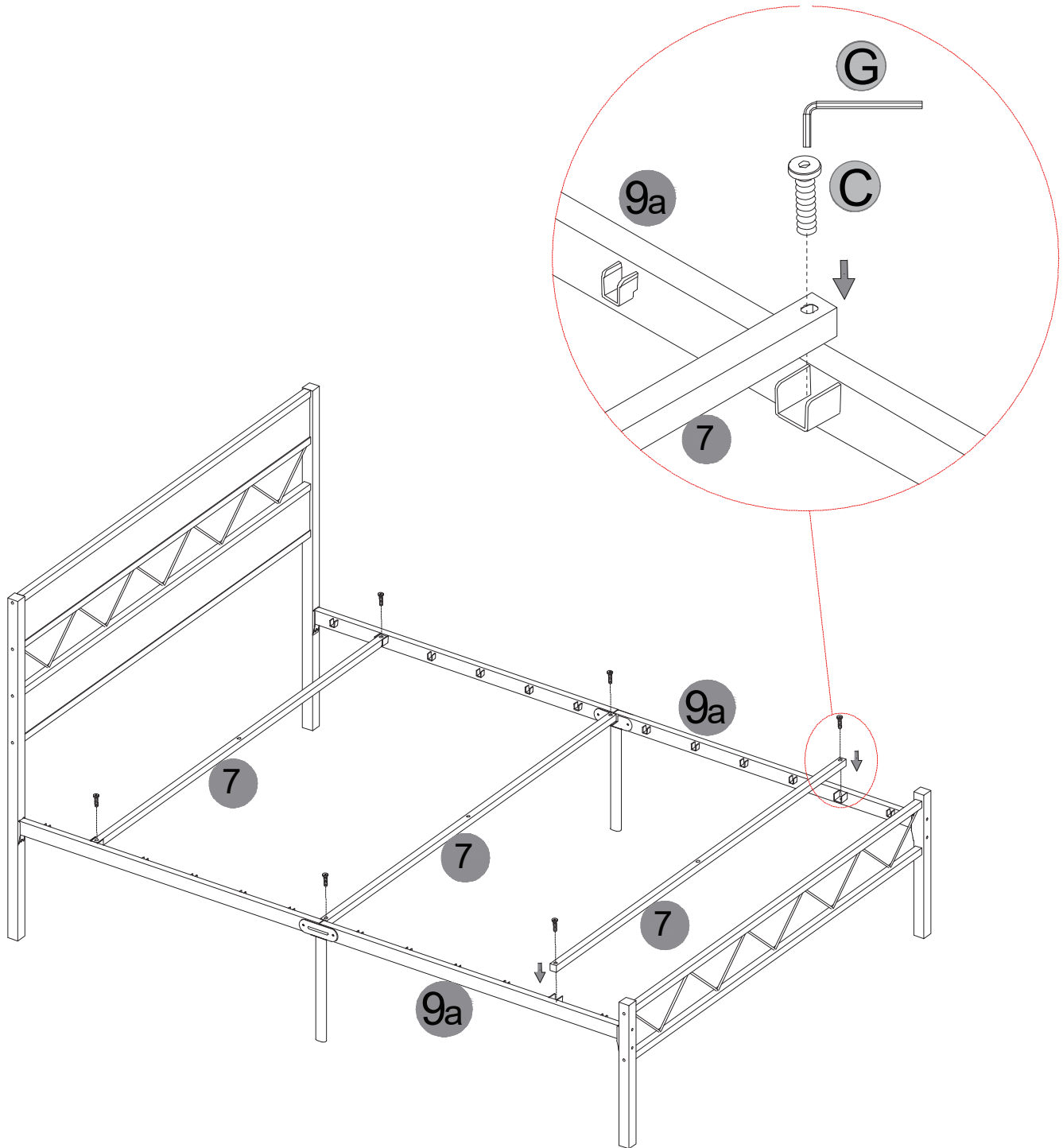

Step 6

	Gx1		Kx3		Nx1
---	-----	--	-----	--	-----

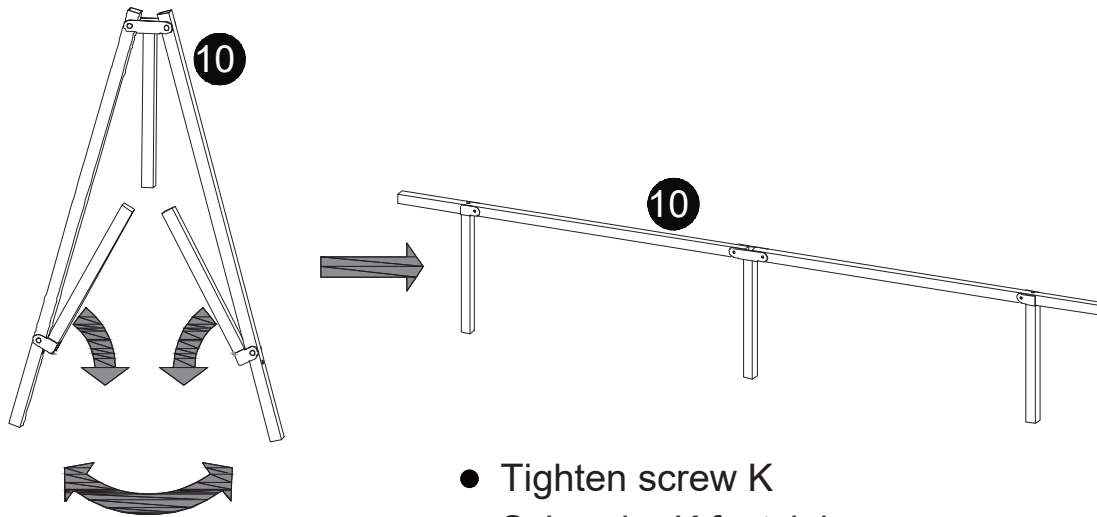

- Tighten screw K
- ★ Schraube K festziehen
- ▲ Serrer la vis K

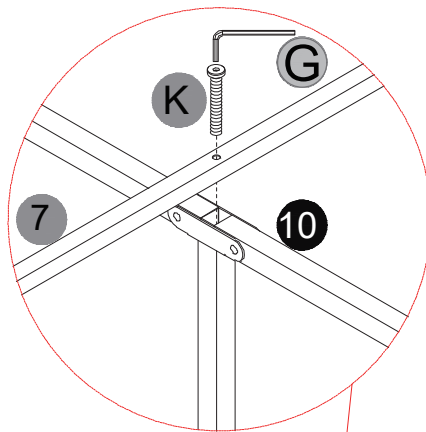

- Unroll part N to pad the entire length of part 10 to eliminate squeaks
- ★ Rollen Sie Bauteil N aus, um die gesamte Länge von Bauteil 10 zu polstern und somit Quietschgeräusche zu beseitigen.
- ▲ Dérouler la pièce N pour rembourrer la pièce 10 sur toute sa longueur afin d'éliminer les grincements.

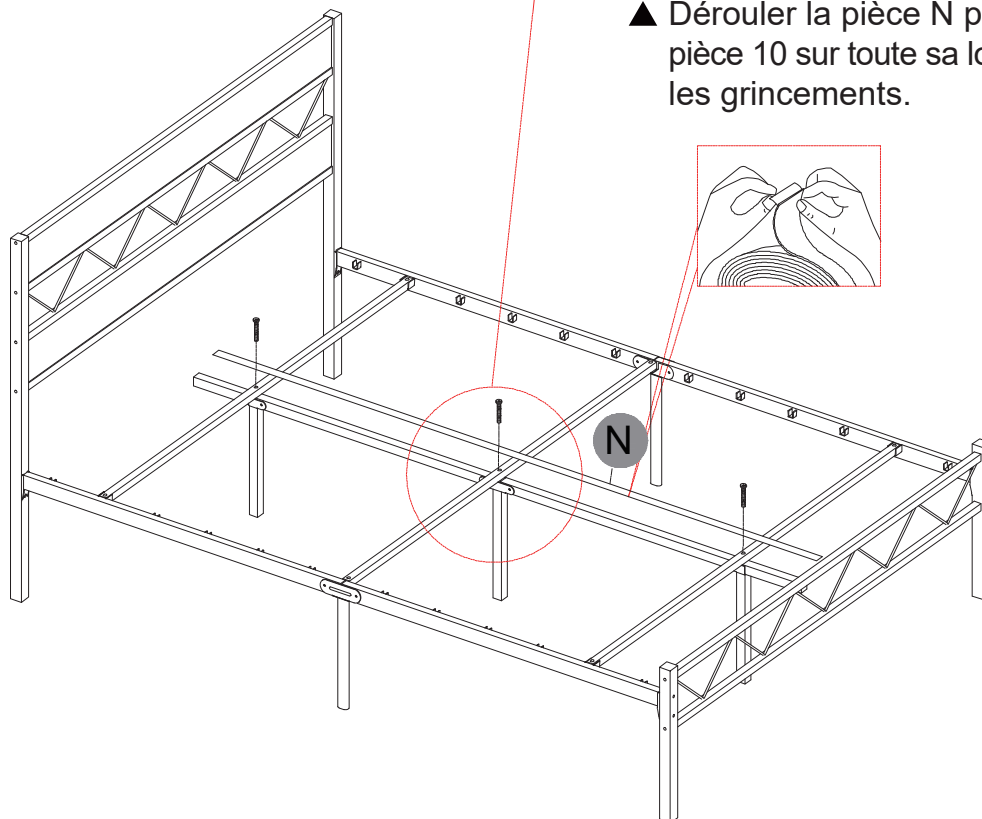
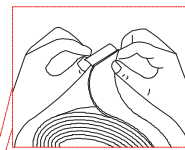

Step 7

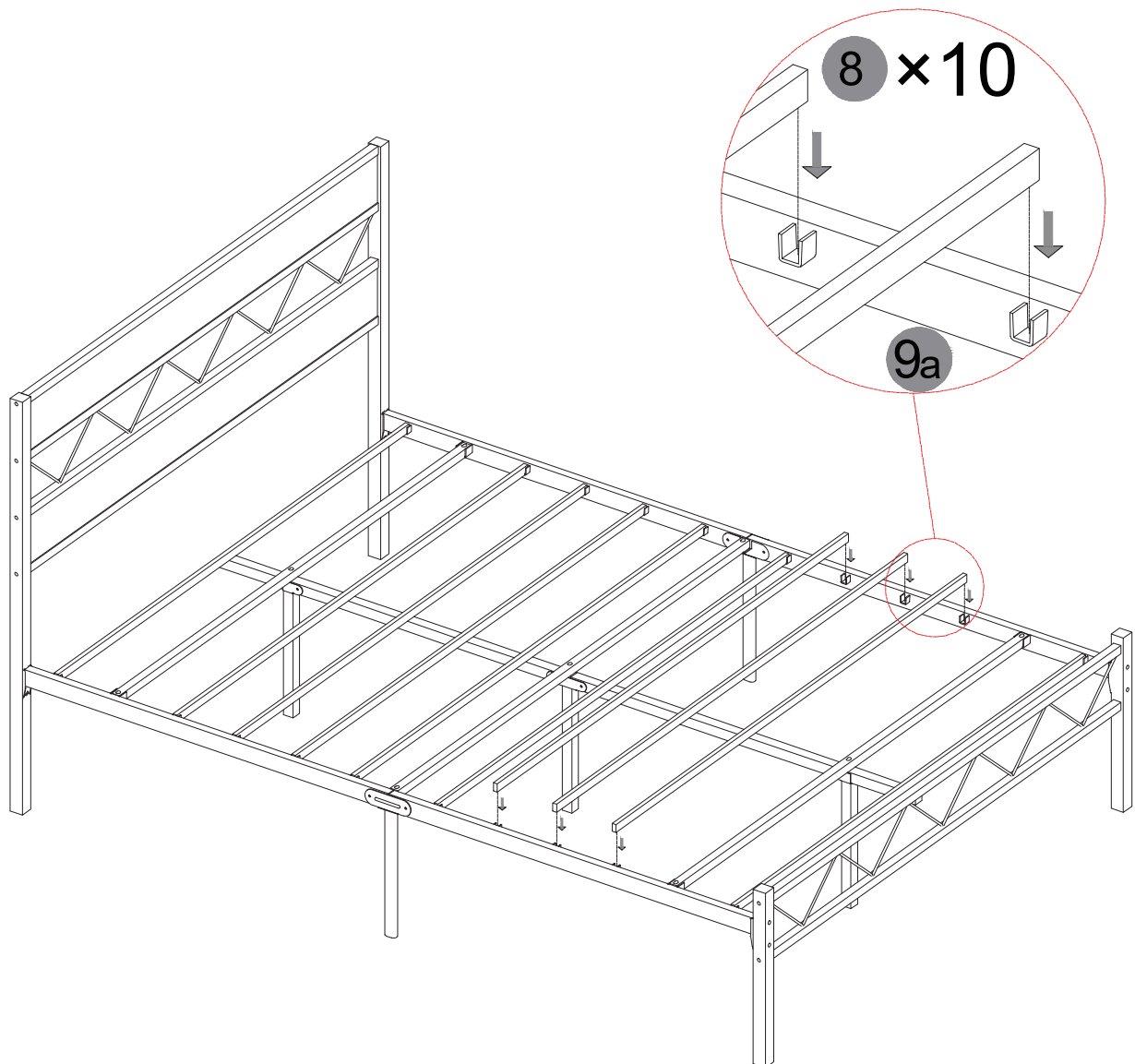

- Note: Now remember to double check all screws are properly fastened
- ★ Hinweis: Vergessen Sie jetzt nicht, zu überprüfen, ob alle Schrauben richtig angezogen sind.
- ▲ Remarque : N'oubliez pas de vérifier que toutes les vis sont bien serrées.