

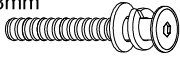







ASSEMBLY INSTRUCTIONS

MODEL : SOFA - 1 SEATER

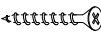
IMPORTANT NOTE :

- * PLACE ALL WOODEN PARTS ON A CLEAN AND SMOOTH SURFACE SUCH AS A RUG OR CARPET TO AVOID THE PARTS FROM BEING SCRATCHED.
- * BEFORE YOU BEGIN, KINDLY FOLLOW THE ASSEMBLY INSTRUCTIONS STEP BY STEP.

HARDWARE LIST		
A	JCBC M6 x 50mm + S/W M6 + F/W M6 x 13mm 	6PCS
B	ALLEN KEY M4 	1PC
C	BARREL NUT M6 x 13mm 	4PCS
D	WOOD BUTTON Ø 14.5 	6PCS
E	FH SCREW #8 X 32mm 	2PCS
F	WOOD DOWEL M10 x 40mm 	4PCS
G	L - BRACKET 	2PCS
H	CSK SCREW M3.5 x 16mm 	4PCS

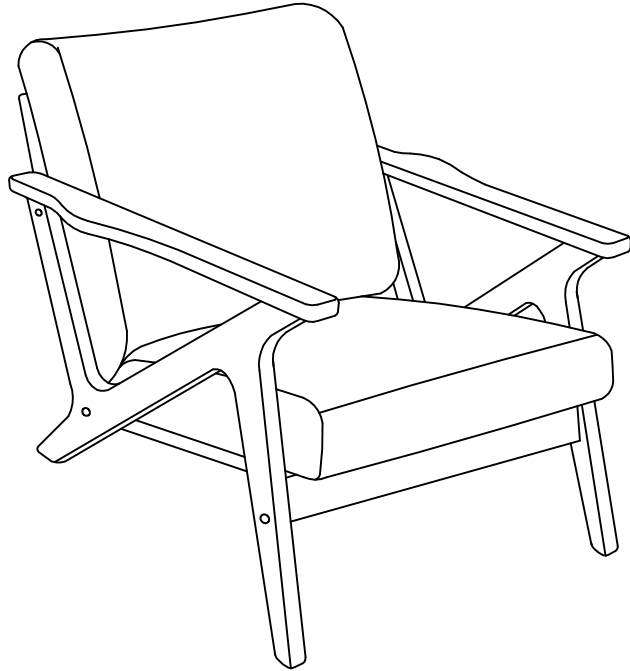

COMPLETED SOFA ASSEMBLY.

PART LIST		
1	SOFA LEG (L/R)	2PCS
2	FRONT RAIL	1PC
3	BACK FRAME	1PC
4	SEAT FRAME	1PC

STEP 1

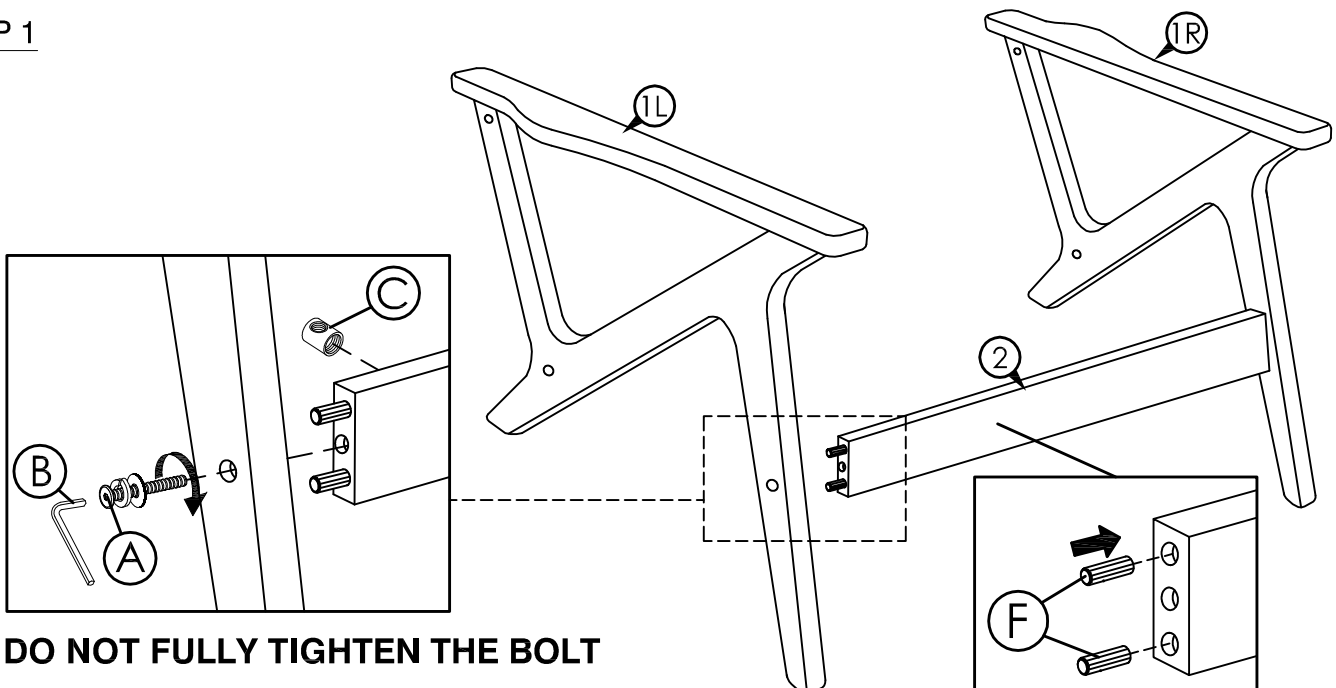

ASSEMBLY INSTRUCTIONS

STEP 2

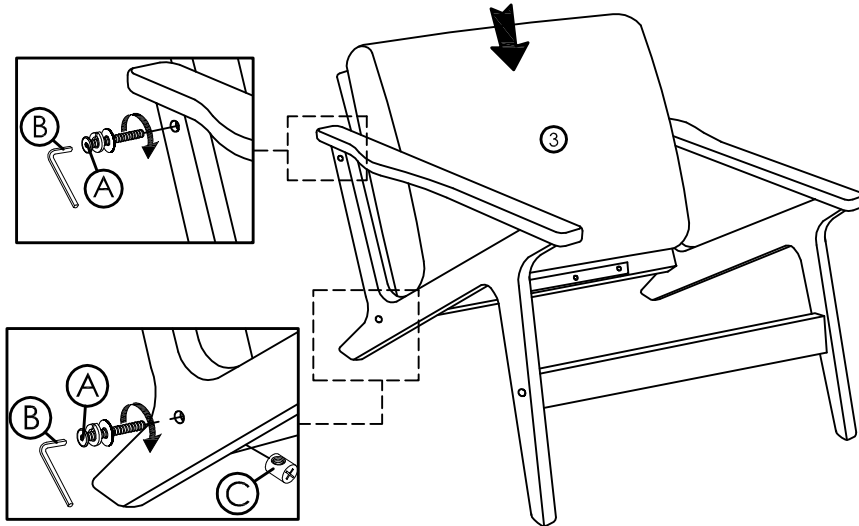

STEP 3 (NEED 2 PERSONS)

Note:

Push the cushion seat harder before fixing the screws (step 3.a).

Step 3.b

Step 3.a

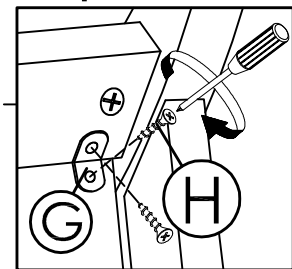
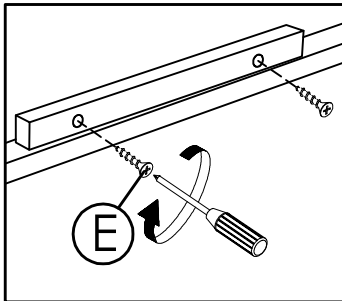

STEP 4

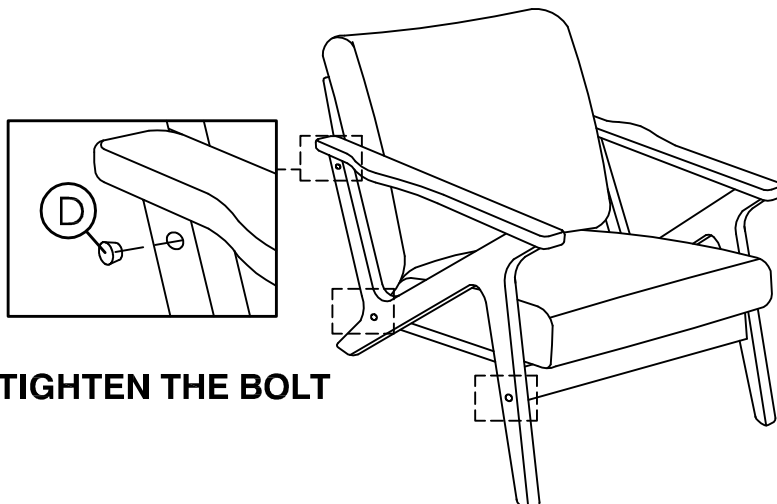

FULLY TIGHTEN THE BOLT