

ASSEMBLY INSTRUCTION

FULL METAL BED

PART LIST:



A: Headboard Leg
2PCS

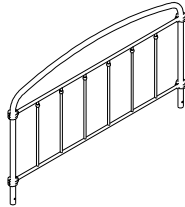

B: Headboard
1PC

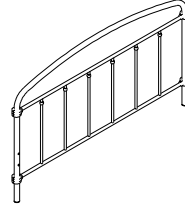

C: Footboard
1PC

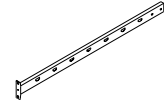

D: Side Rail
2PCS

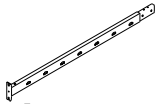

E: Side Rail
2PCS

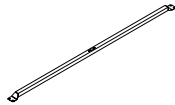

F: Brace
1PC

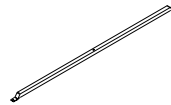

G: Brace
2PCS

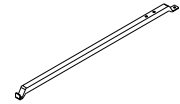

H: Brace
2PCS



I: Leg
3PCS



J: Center Support
Legs
2PCS

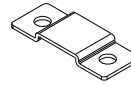

K: Bracket
1PC

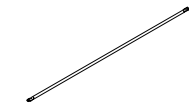

L: Slat
14PCS



M: Slat Connector
28PCS

HARDWARE LIST:



1 : Bolt
1/4"-20*22mm
16PCS



2 : Bolt
5/16"-20*19mm
8PCS



3 : Bolt
1/4"-20*17.5mm
6PCS



4 : Bolt
1/4"-20*40mm
4PCS



5 : 1/4"
4PCS



6 : 4mm
1PC

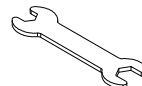

7 : Wrench
1PC

NOTE: PLEASE DO NOT TIGHTEN ALL BOLTS UNTIL THE BED IS ASSEMBLED COMPLETELY.

STEP 1:

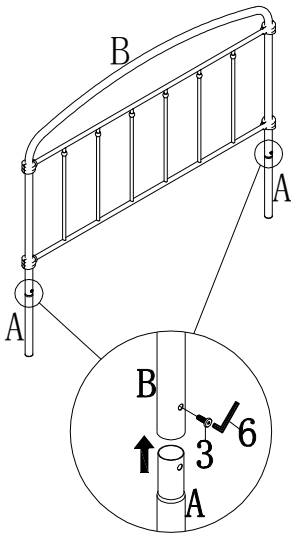

Hardware 3: 2 pcs

STEP 2:

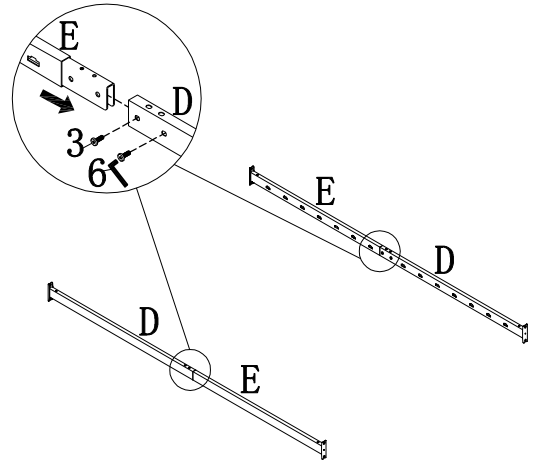

Hardware 3: 4 pcs

STEP 3:

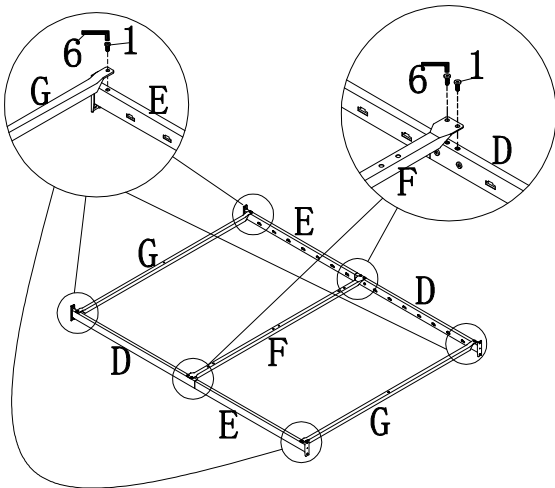

Hardware 1: 8 pcs

STEP 4:

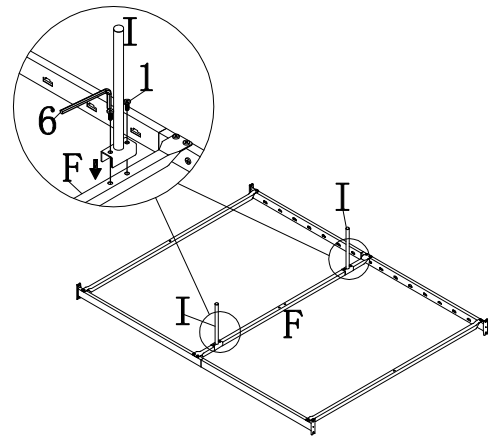

Hardware 1: 4 pcs

STEP 5:

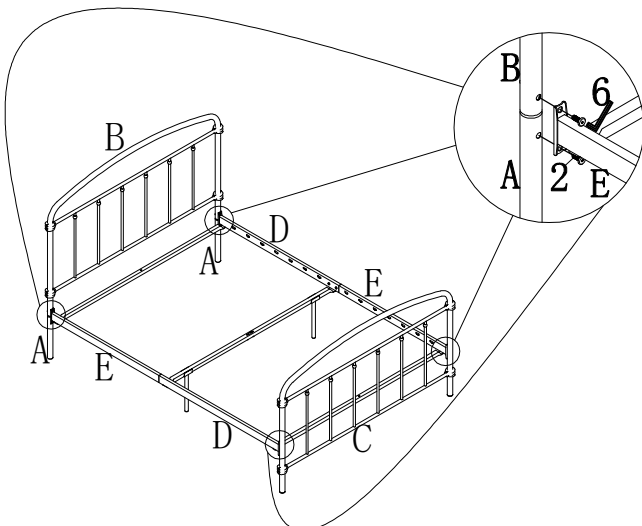

Hardware 2: 8 pcs

STEP 6:

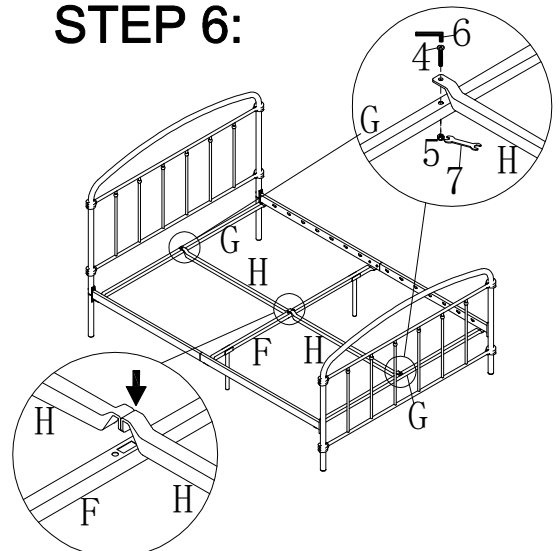

Hardware 4: 2 pcs
Hardware 5: 2 pcs

NOTE: PLEASE DO NOT TIGHTEN ALL BOLTS UNTIL THE BED IS ASSEMBLED COMPLETELY.

STEP 7:

Hardware 1: 4 pcs
Hardware 4: 2 pcs
Hardware 5: 2 pcs

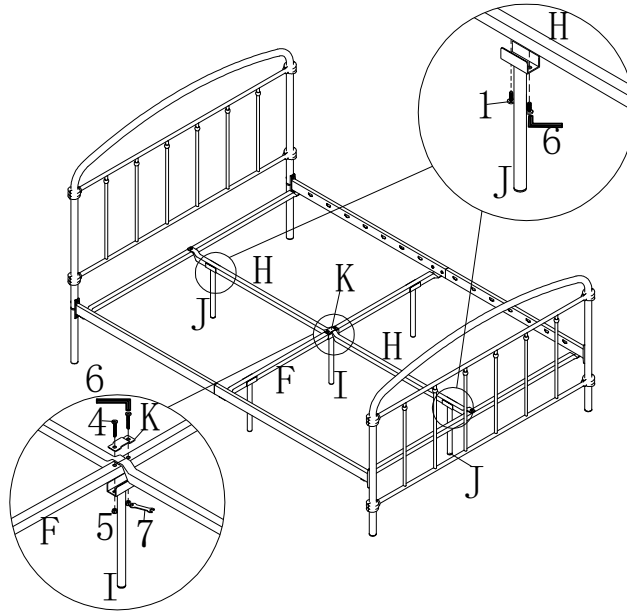

STEP 8:

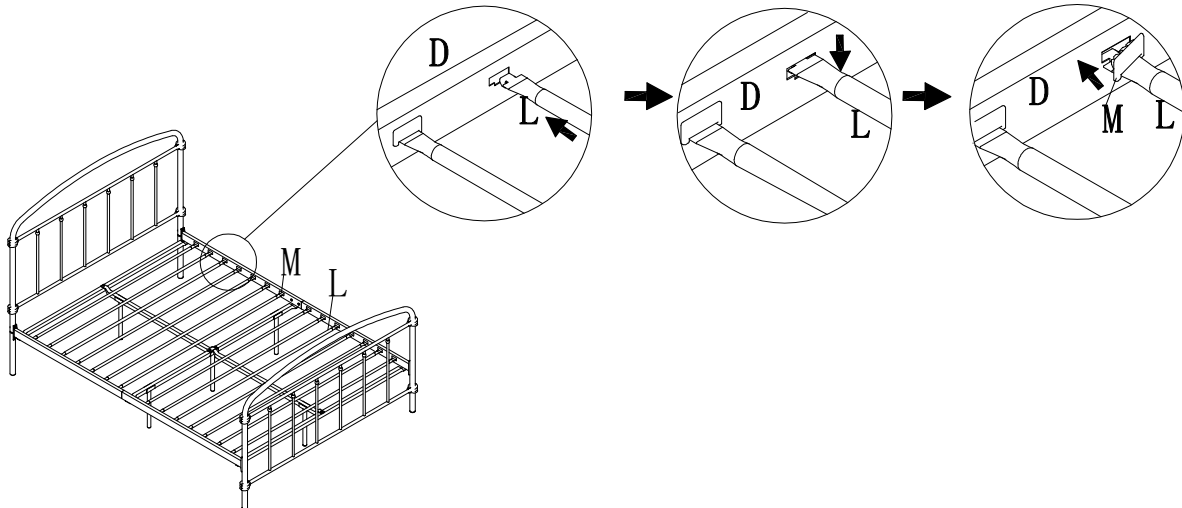

COMPLETED:

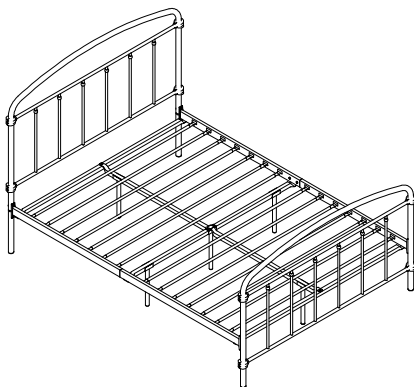

 For items use on wooden floor, hard surfaces or carpets, it is recommended to install protective pads under all legs and supports to avoid/prevent from damages/scratches and discoloration.