

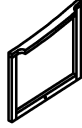

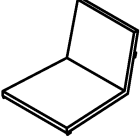



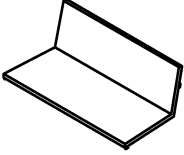

# ASSEMBLY INSTRUCTIONS

## PART LIST

1		x4
2		x1
3		x1
4		x1
5		x1

## HARDWARE LIST

NO.	DESCRIPTION	SKETCH	Q.TY
A	Allen Bolt M6x25		16
B	Allen Bolt M6x40		4
C	Flat Washer M6x16mm		16
D	Allen Wrench M4		1

### STEP 1

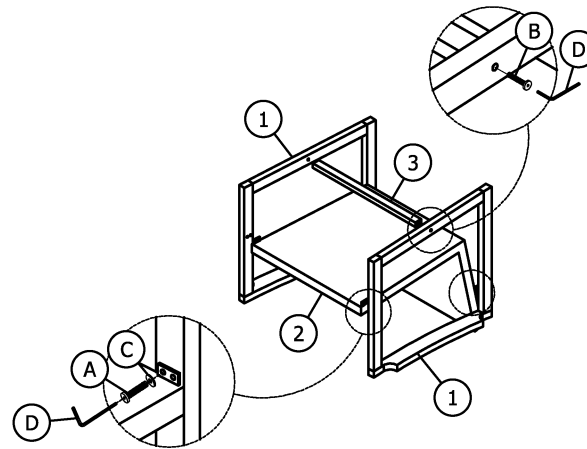

### STEP 2

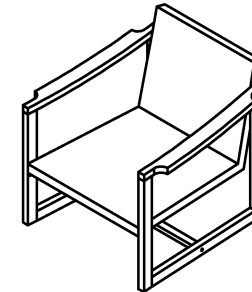

### STEP 3

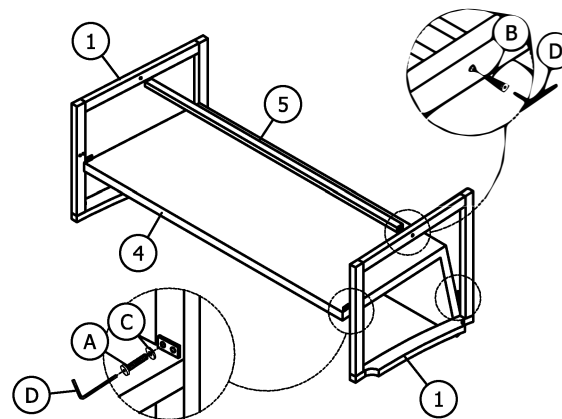

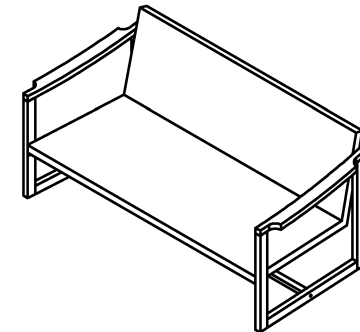

### STEP 4



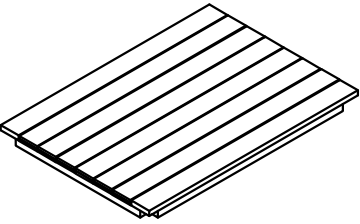

# ASSEMBLY INSTRUCTIONS

## PART LIST

1		x1
2		x4

## HARDWARE LIST

NO.	DESCRIPTION	SKETCH	Q.TY
A	Allen Bolt M6x55mm		8
B	Flat Washer M6x16mm		8
C	Allen Wrench M4		1

### STEP 1

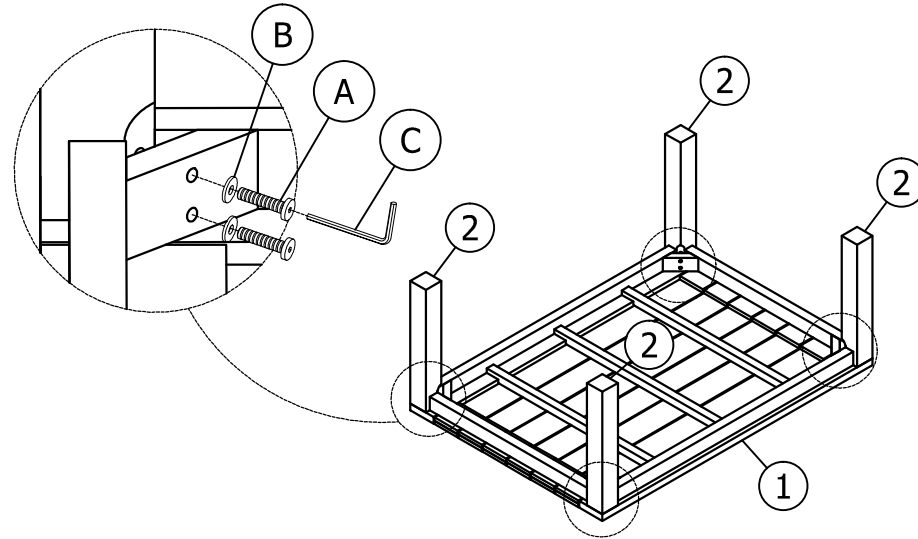

### STEP 2

