

# ASSEMBLY INSTRUCTIONS

## TOOLS REQUIRED:

- Allen wrench (supplied, part # J)
- Spanner Wrench (supplied, part # H)

## BEFORE YOU START:

1. Check the parts against the parts list to make sure all items are present.
2. Assemble your furniture on a soft, flat surface to avoid scratching the finish.
3. **CAUTION:** Do not over tighten screws, nuts or bolts during assembly.
4. Your furniture may require occasional tightening.

## INSTRUCTIONS:

1. Align wooden dowels at the frame "C" with pre-drilled holes in the stretcher. Attach the stretcher to the two frame "C", using the Bolt (A) and Hex Nut + Curved Washer (B). Tighten with Wrench (H). (See Figure 1)  
Important: Do not over-tighten.

2. Attach the leg to the frame seat, using Flat Washer (F), Lock Washer (D), Nuts (C) and tighten all nuts with Wrench (H). (See Figure 2)

3. Attach the brace to the four feet, using Bolt (I), Lock washer (E) and Flat washer (G). Tighten with Wrench (J). (See Figure 3)

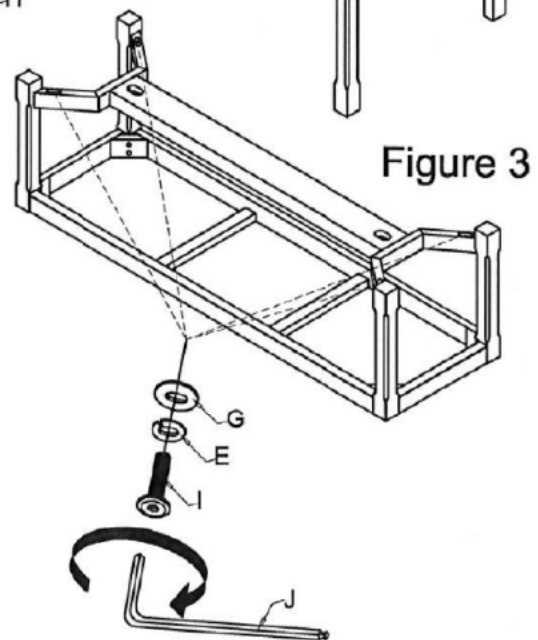
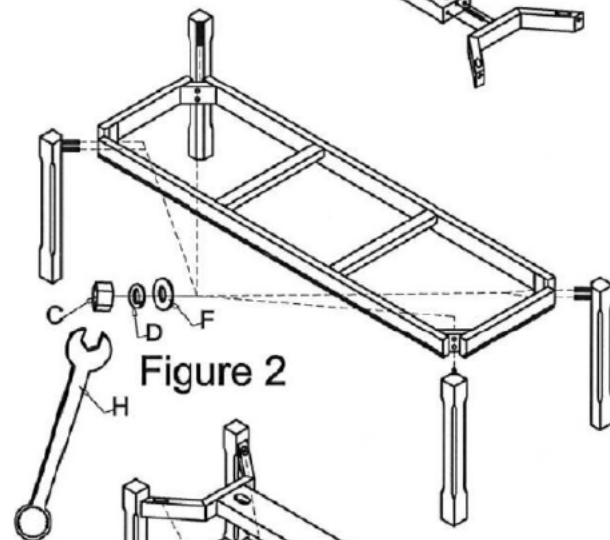
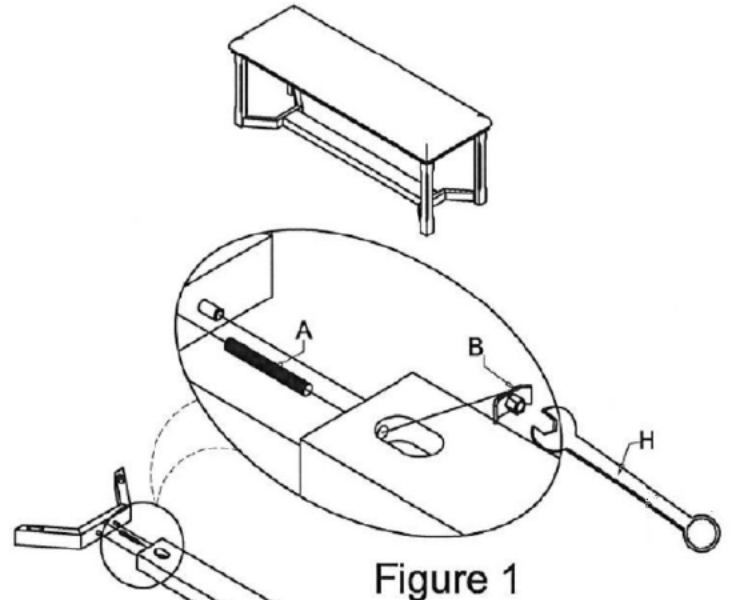

No.	Hardware List	Q'ty
A	 Thread Bolt Ø5/16"x3"	2
B	 Hex Nut Ø5/16" + Curved Washer Ø5/16"	2
C	 Hex Nut Ø5/16"	8
D	 Lock Washer Ø5/16"	8
E	 Lock Washer Ø1/4"	4
F	 Flat Washer Ø5/16"	8
G	 Flat Washer Ø1/4"	4
H	 Spanner Wrench 13mm	1
I	 Bolt Ø1/4"x1-1/2"	4
J	 Allen Wrench 4mm	1