

# User's Manual



**Please Do Not Return the Product to the Store.  
Contact us with any questions.**



# Installation precautions

- a) After opening the product package, please check the completeness of the parts listed in the "Standard Parts List". If there are any defects, please contact your local dealer immediately.
- b) The installation size of the faucet should match the installation size of the embedded water inlet pipe.
- c) The main part of the faucet has been tested and debugged by the factory. Do not disassemble it by yourself to avoid affecting the performance.
- d) The faucet must be connected with the hot and cold water pipes. Pay special attention to the hot water on the left and cold water on the right.
- e) Before installing the faucet, be sure to remove the impurities and sludge in the buried pipeline first, so as not to block and affect the water output function.
- f) After installation, please turn on the water source switch, and then check whether the links are tightly connected to ensure that there is no leakage.
- g) The internal structure of the faucet contains non-high temperature resistant components such as silica gel. Do not use it in high temperature environments. Do not use it for a long time at a water temperature exceeding 90 ° C.
- h) It is recommended to use water pressure: 0.05Mpa-0.75Mpa.
- i) Do not bend the hose excessively. Make sure that the hose is not deformed after installation.

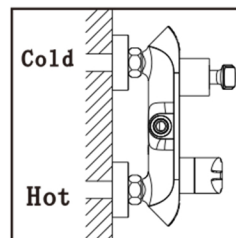
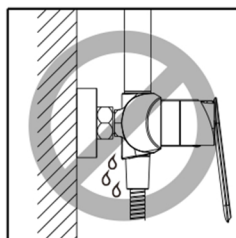
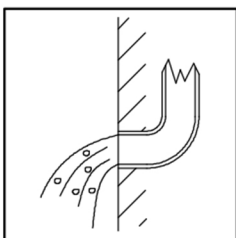
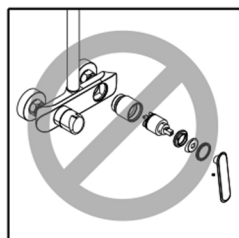

## Recommend Tools And Materials

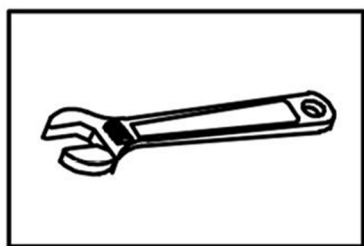

Adjustable Wrench

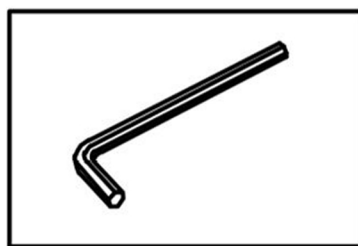

Hexagon wrench

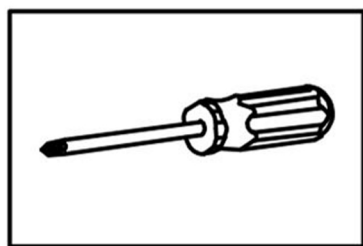

Philips Screwdriver

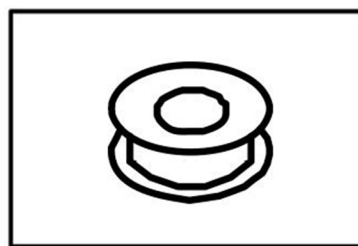

Pipe Tape

# Product size

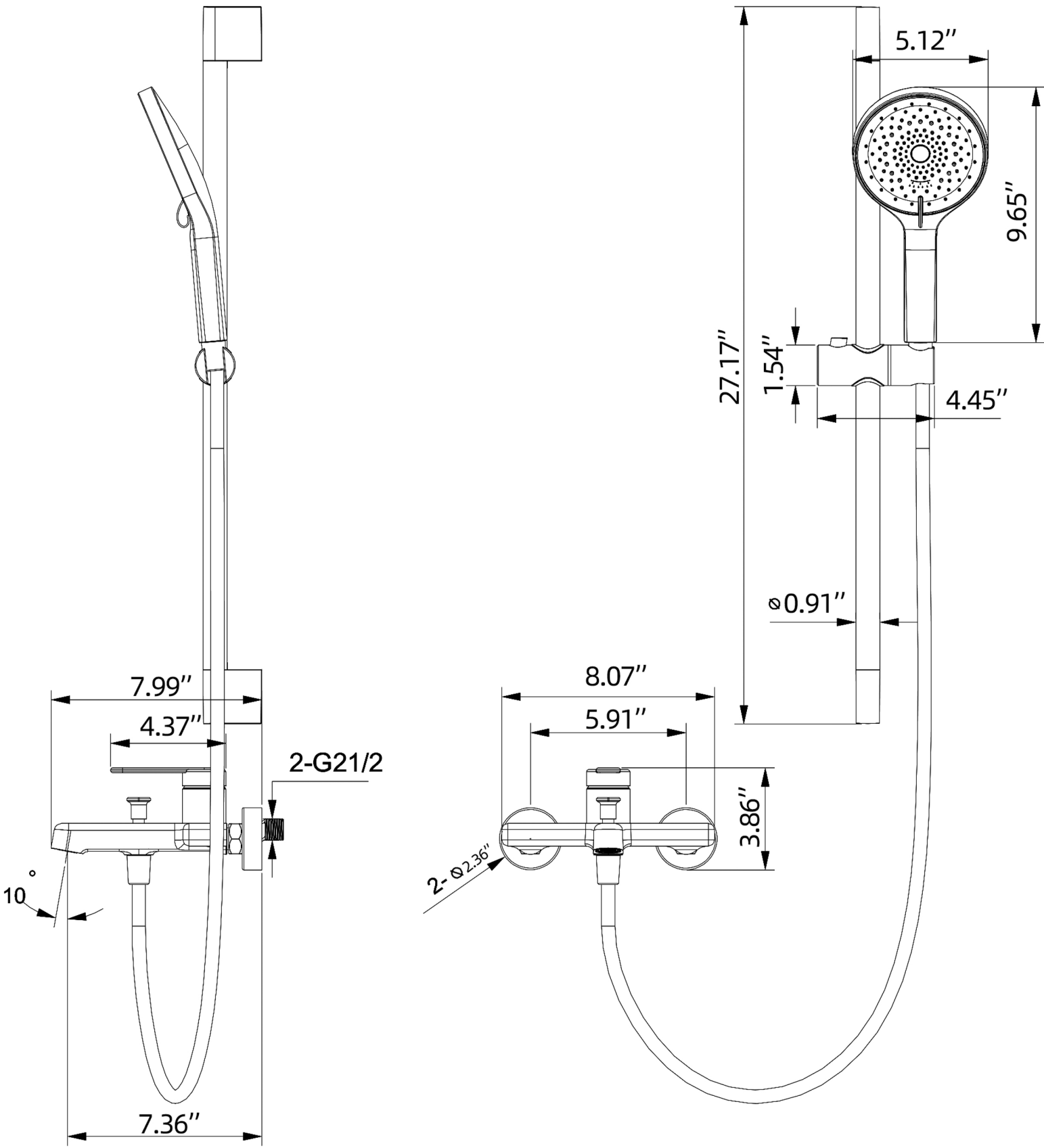

# INSTALLATION STEPS

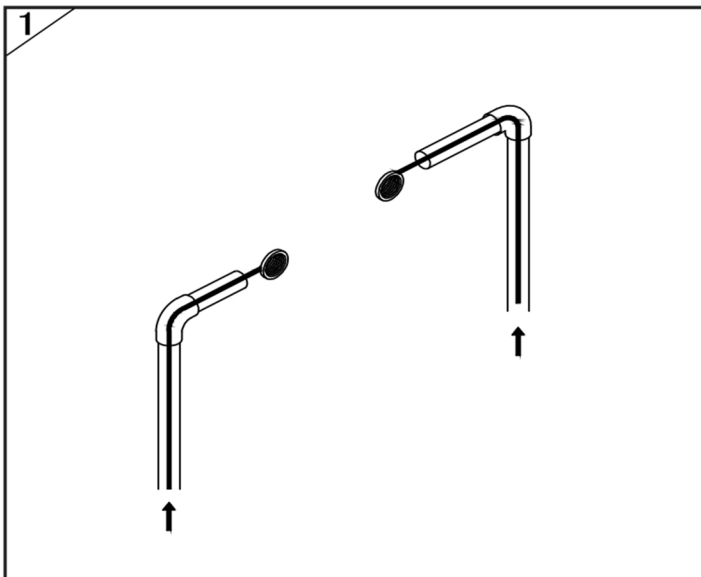

a) The embedded pipeline must be flushed before installing the faucet.

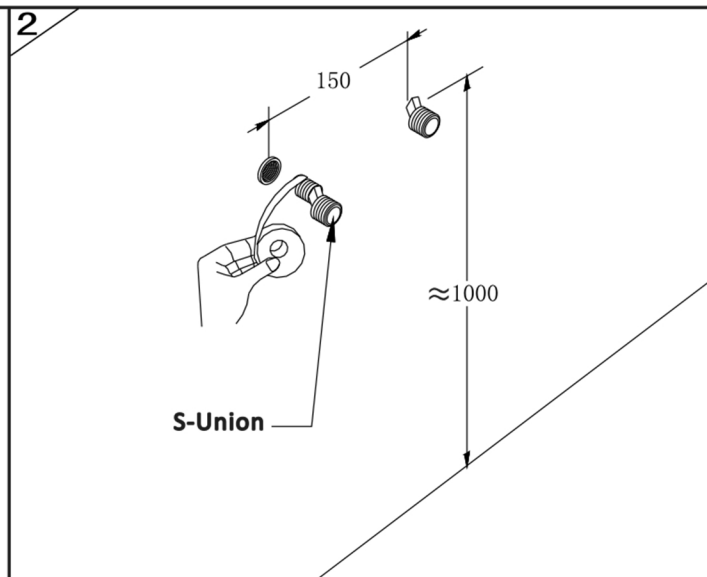

b) The S-Union is wrapped with raw material tape and connected with the buried outlet pipe joint.

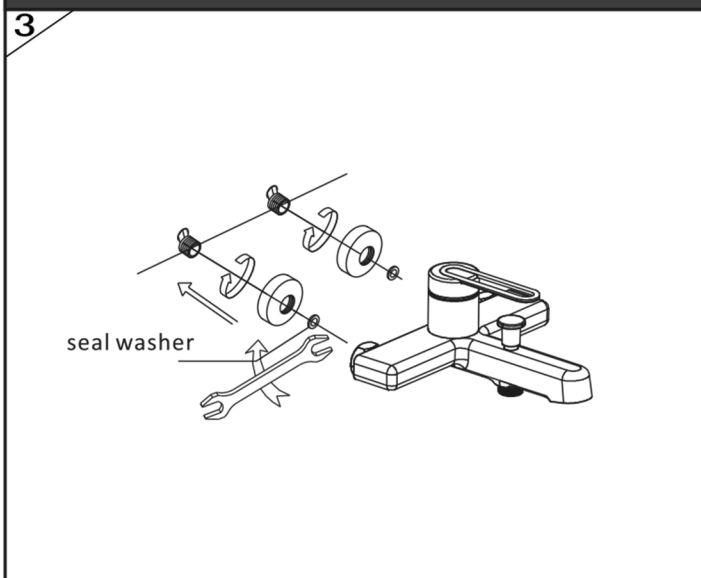

c) Tighten the main body and the S-Union,

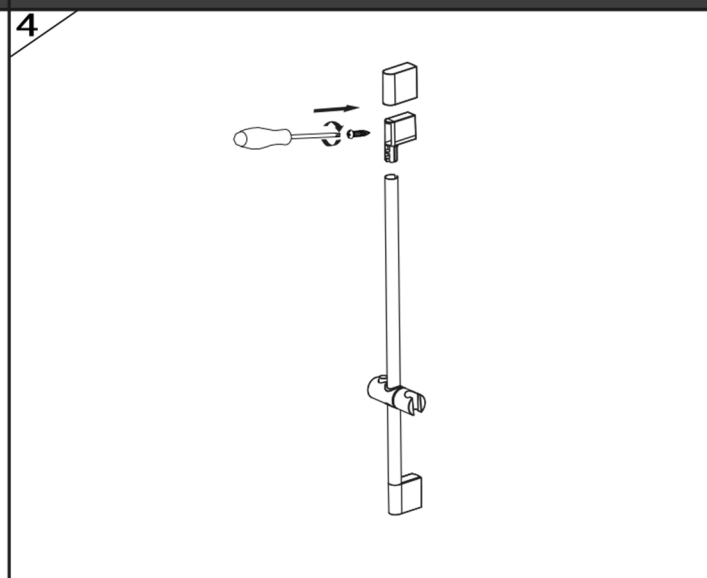

d) Fix the lower end seat, install the bracket, and then fix the upper end seat

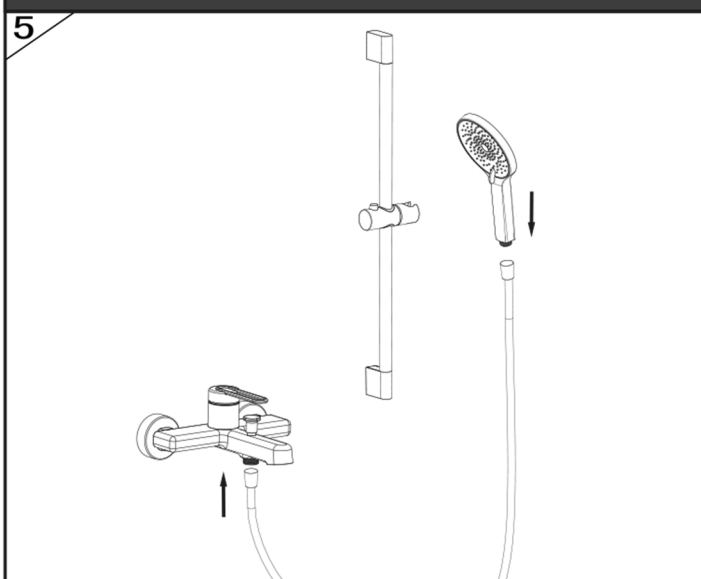

e) Connect the hose and the hand showerhead



f) Turn on the water source switch and check whether there is water leakage at each connection.

## Care and maintenance

**To keep the surface of the faucet smooth and bright, please follow the procedure below:**

- a) Often clean the surface of the faucet with water, and dry the faucet with a soft cloth.
- b) Do not rub the surface of the faucet with detergents such as polishing powder and decontamination powder to avoid abrasion and scratching the product.
- c) Never use acid detergent to clean the faucet, so as not to cause acid detergent to corrode the faucet plating layer.
- d) When using the product, please do not operate the movable parts of the product with force, so as not to affect the service life of the product.



**Please Do Not Return the Product to the Store.  
Contact us with any questions.**