

GB>ASSEMBLY INSTRUCTIONS

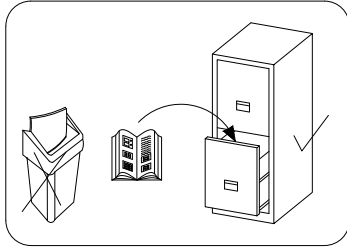

Time to assemble

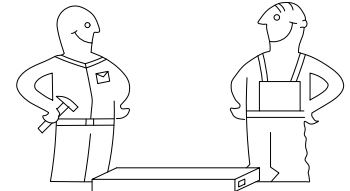
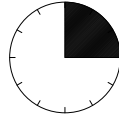

1 hours

Tools required

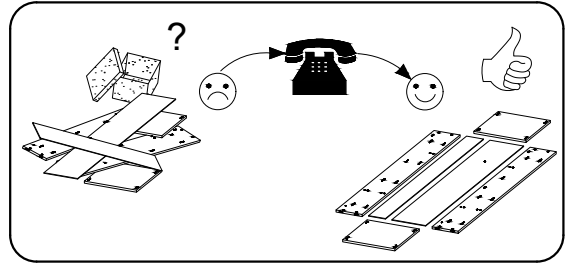
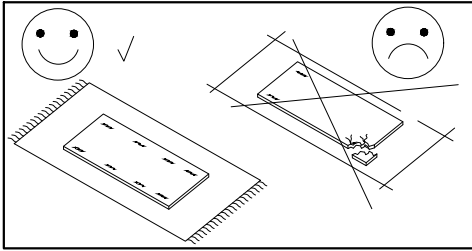
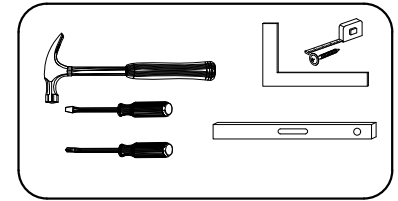

Caution

GB>Please only clean with a duster or a damp cloth. Do not use any abrasive cleaners.

Dear customer, should there be any piece missing or damaged, kindly mark this piece clearly on the attached assembly instructions and return them to us.

Service Card

ACCESSORIES

8.0x30 D 28	4.0x27 G 8	 A 28	Ø15x12 B 28	 X 28	 S 12	 M 4	4.0x20 H2 4	5.0x13 F 16	 KL 2
 I 12	 Z 8	 L 8	 GW 20	4.0x16 H 23	 F 4	 G1 7	 Y 1	 KP 4	 RK 4
Ø 8.0 X3 7	Ø 5.0 X4 4	 L10 4							

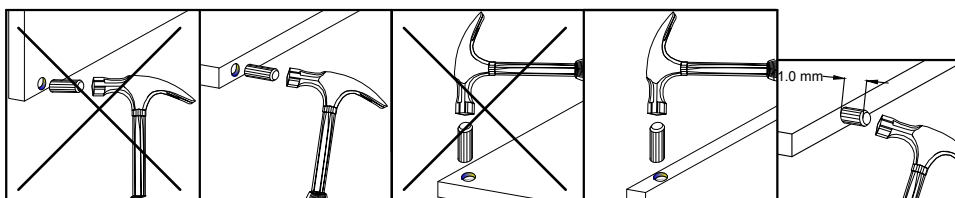

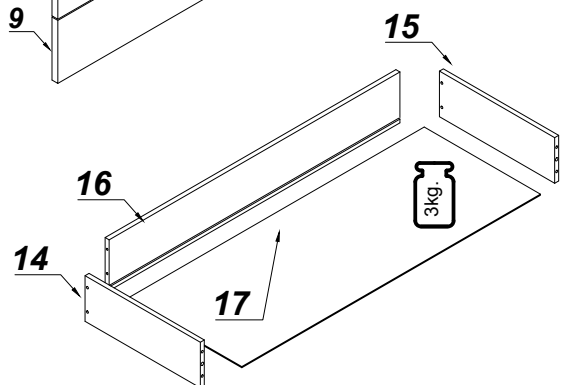
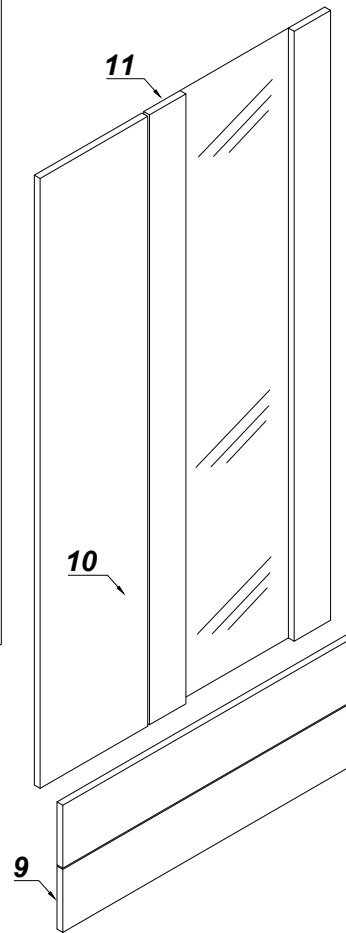
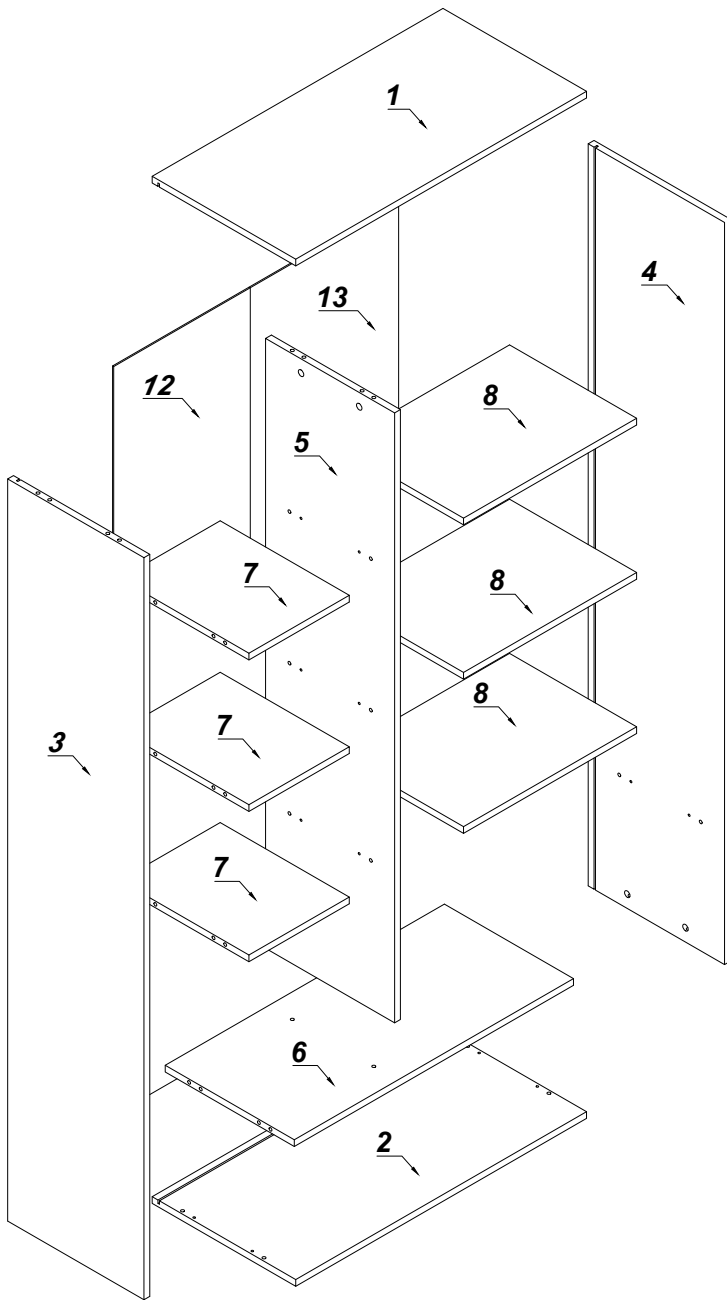
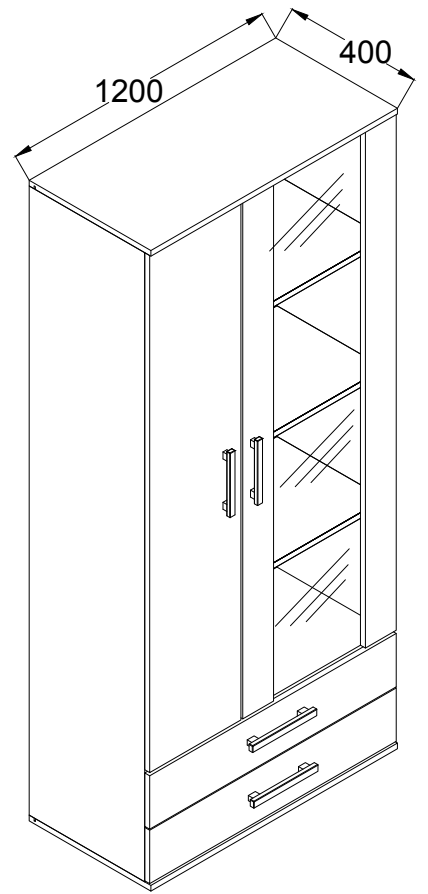

WARIANT A

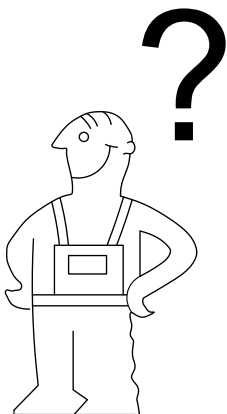
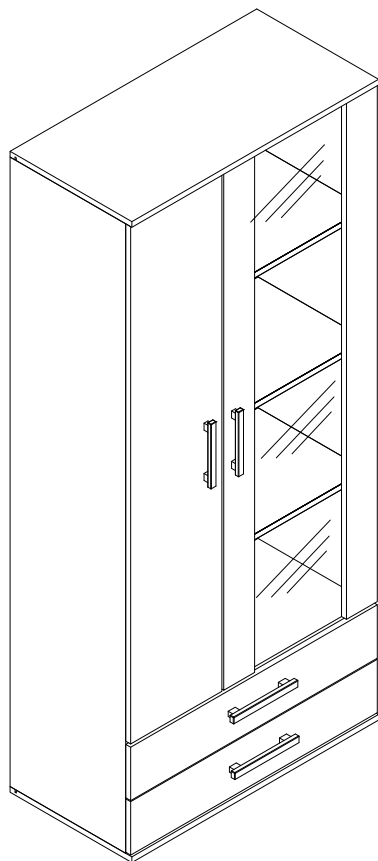

WARIANT B

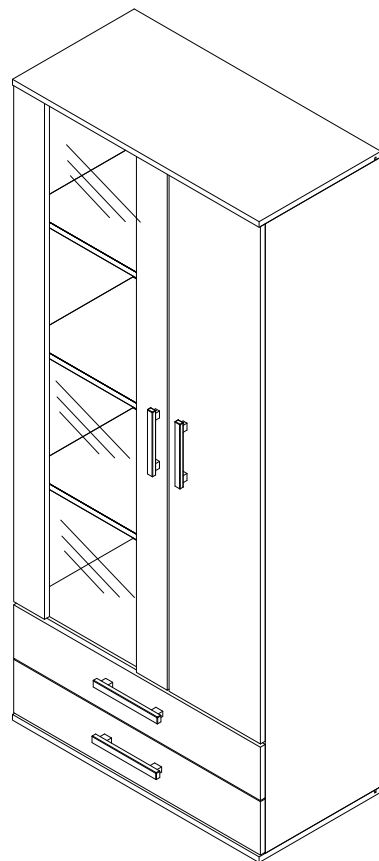

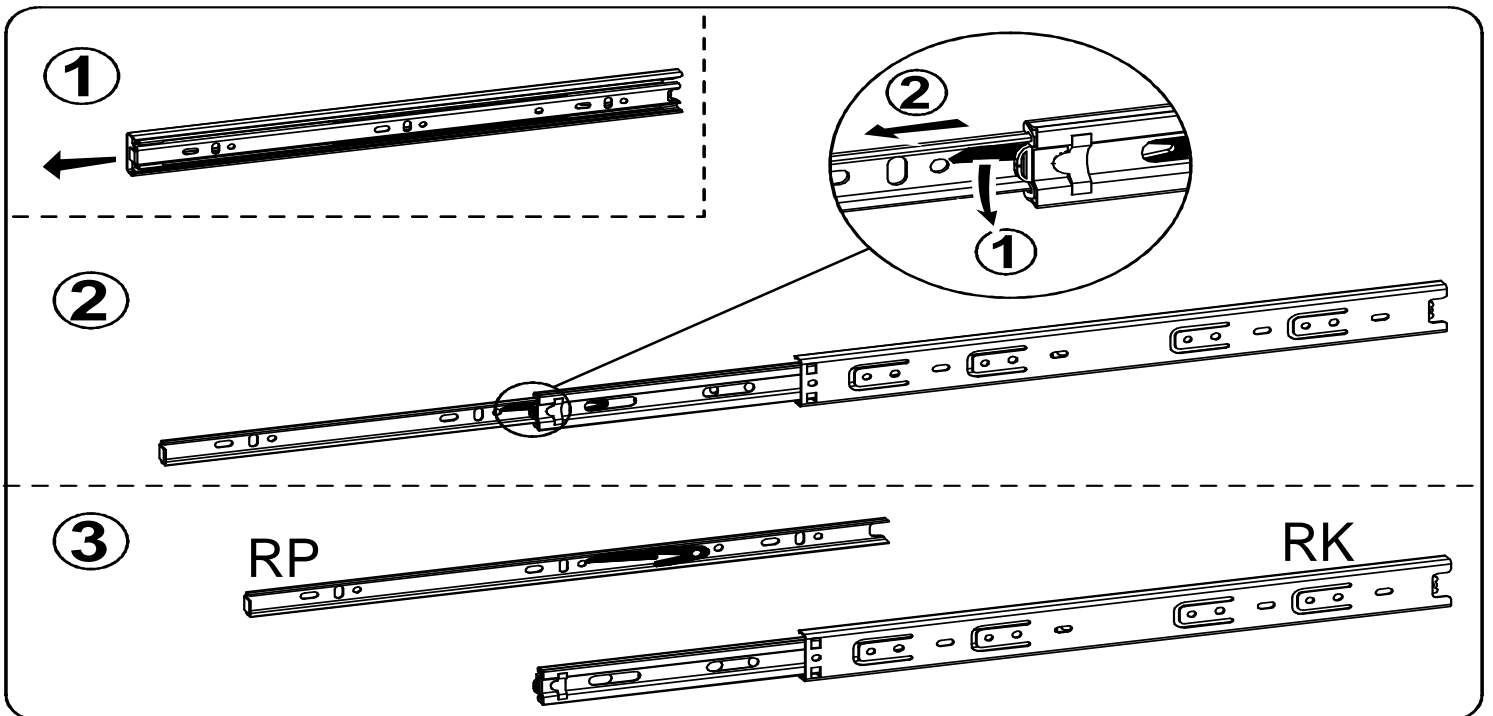
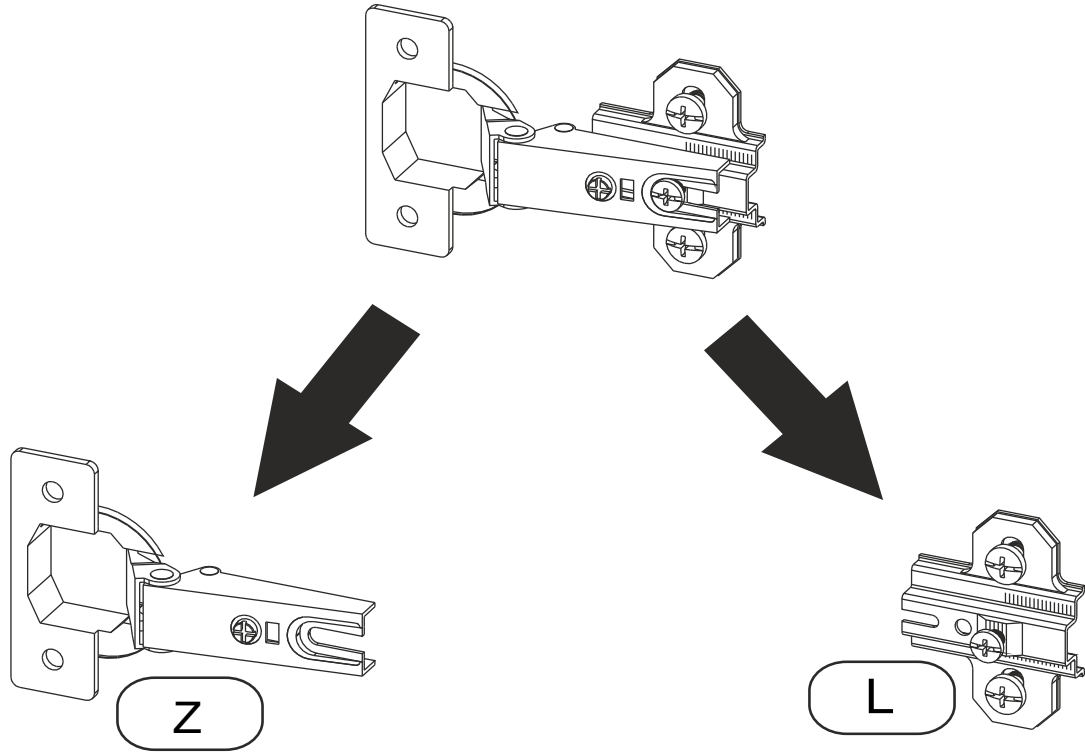
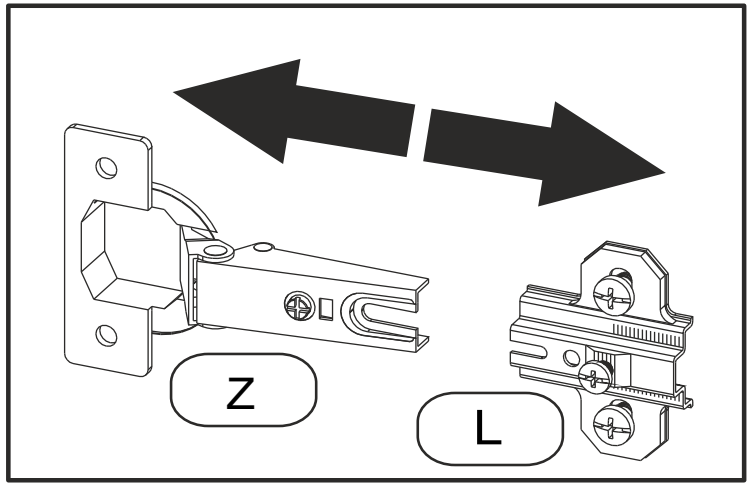
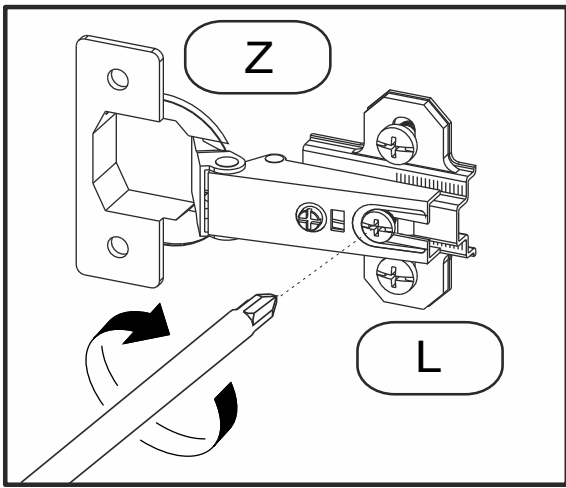

1

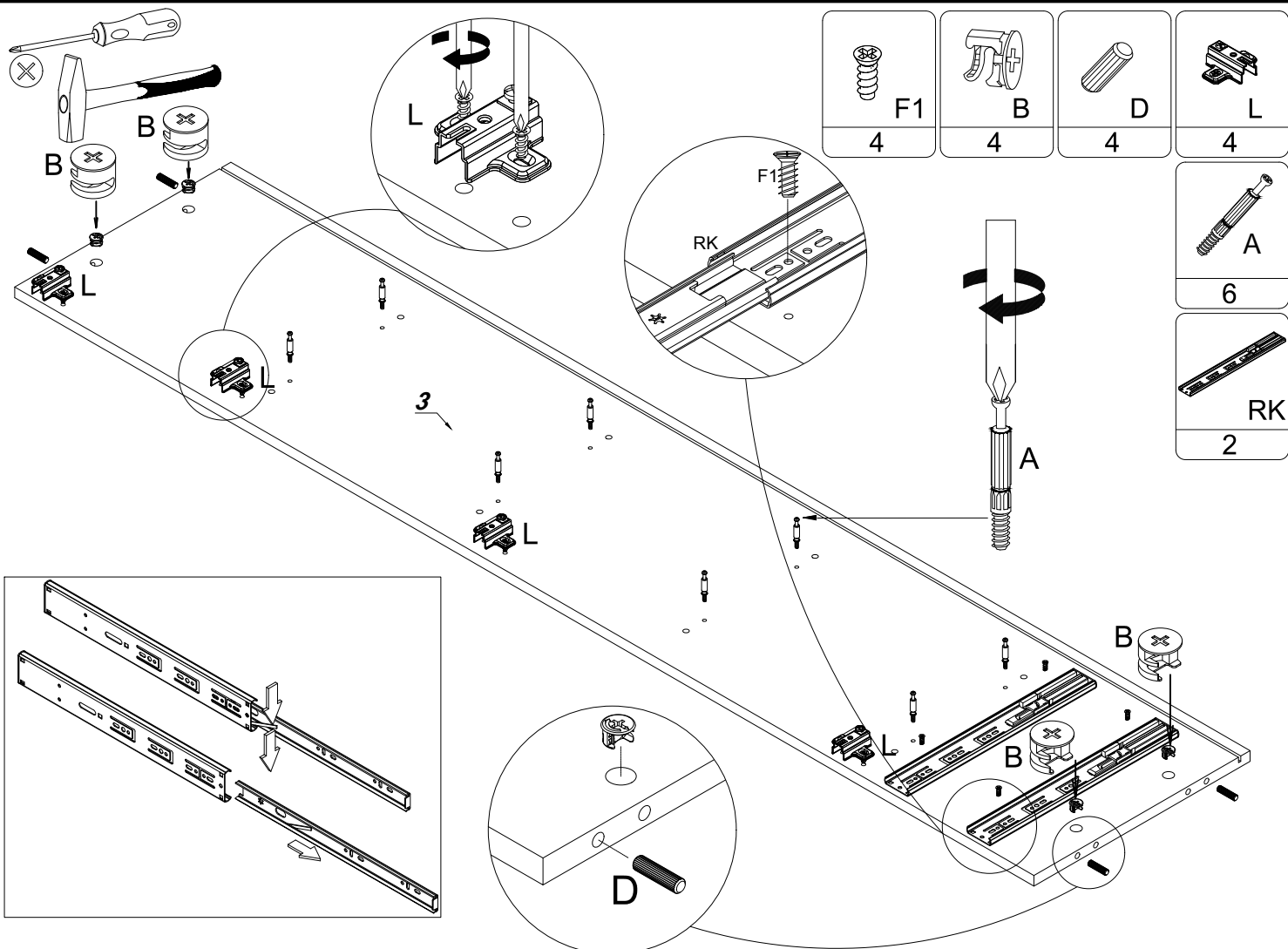

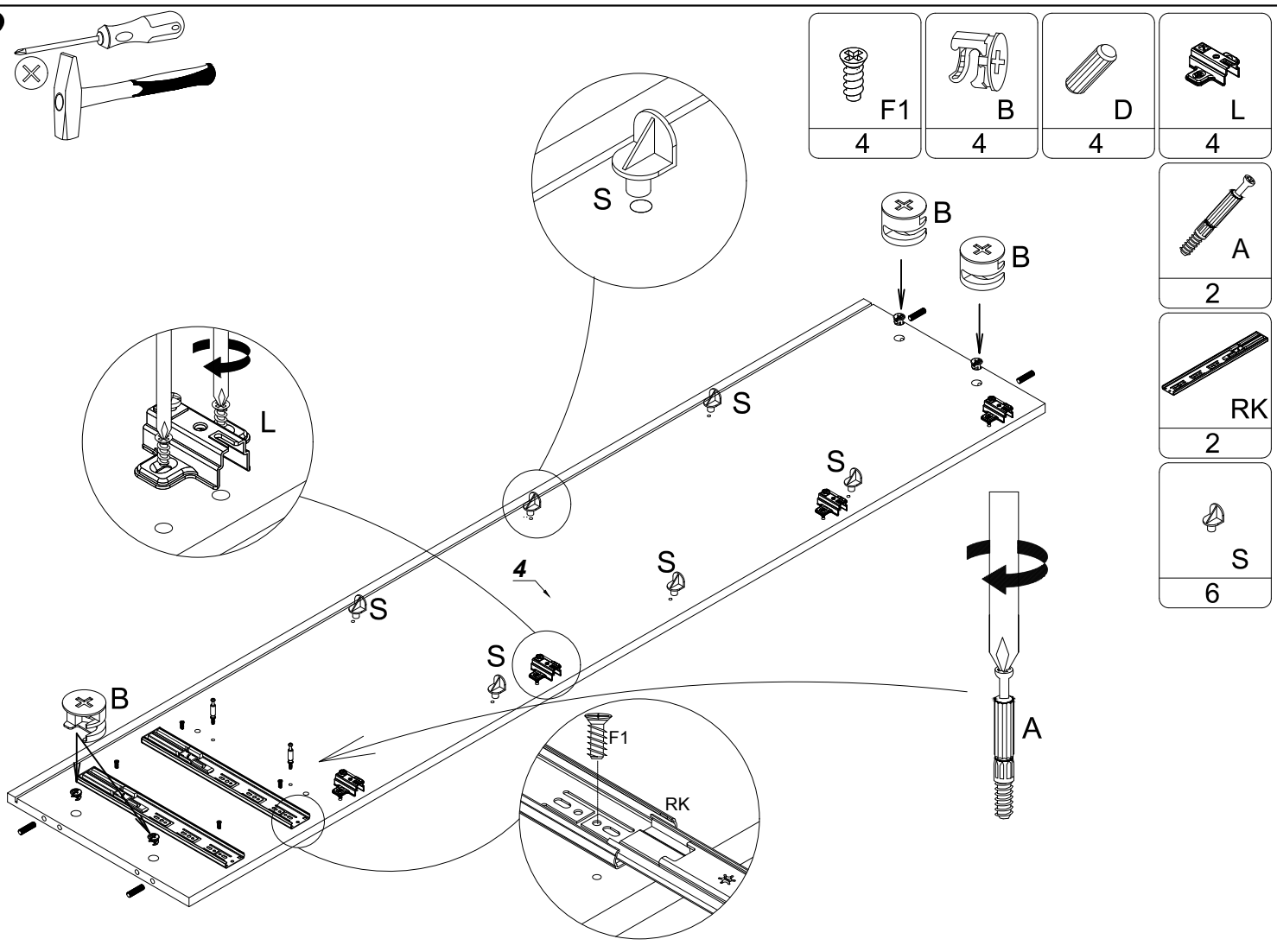

2

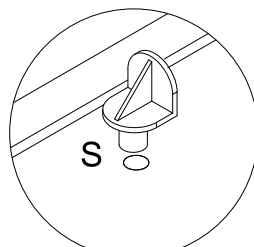
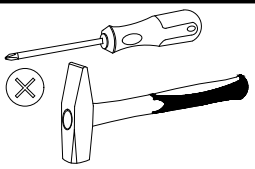

3

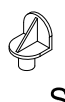



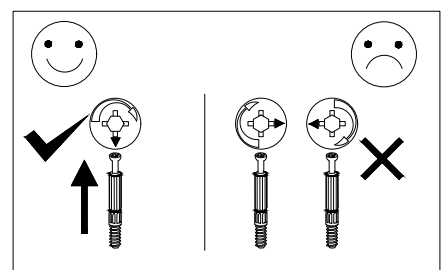
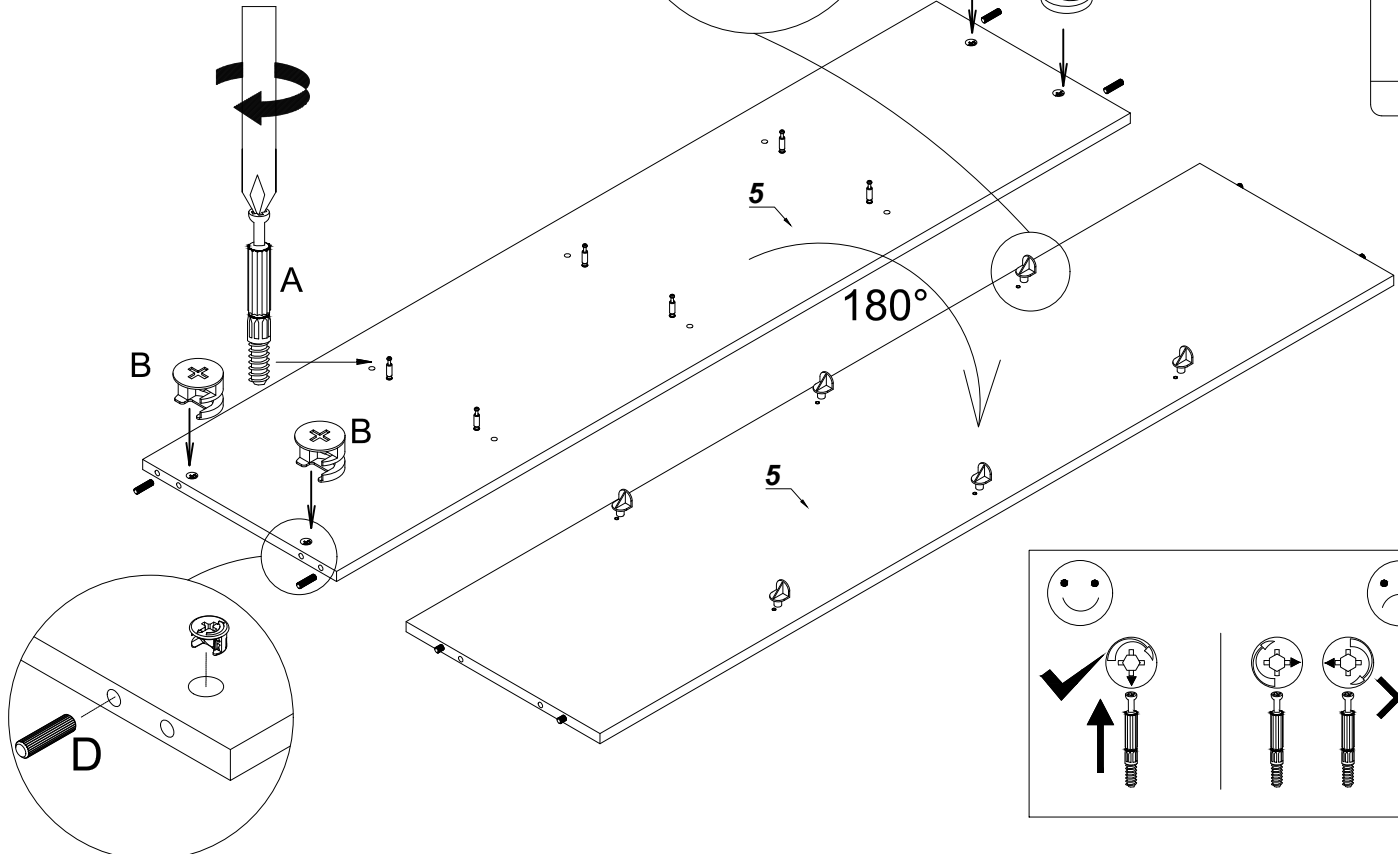

 A 6	 S 6	 B 4
 D 4		

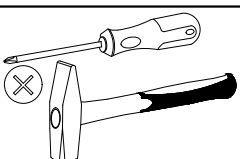

4



 M 4	 A 6	 H2 4	 L10 4
-------------------------------------------------------------------------------------------------	-------------------------------------------------------------------------------------------------	--------------------------------------------------------------------------------------------------	---------------------------------------------------------------------------------------------------

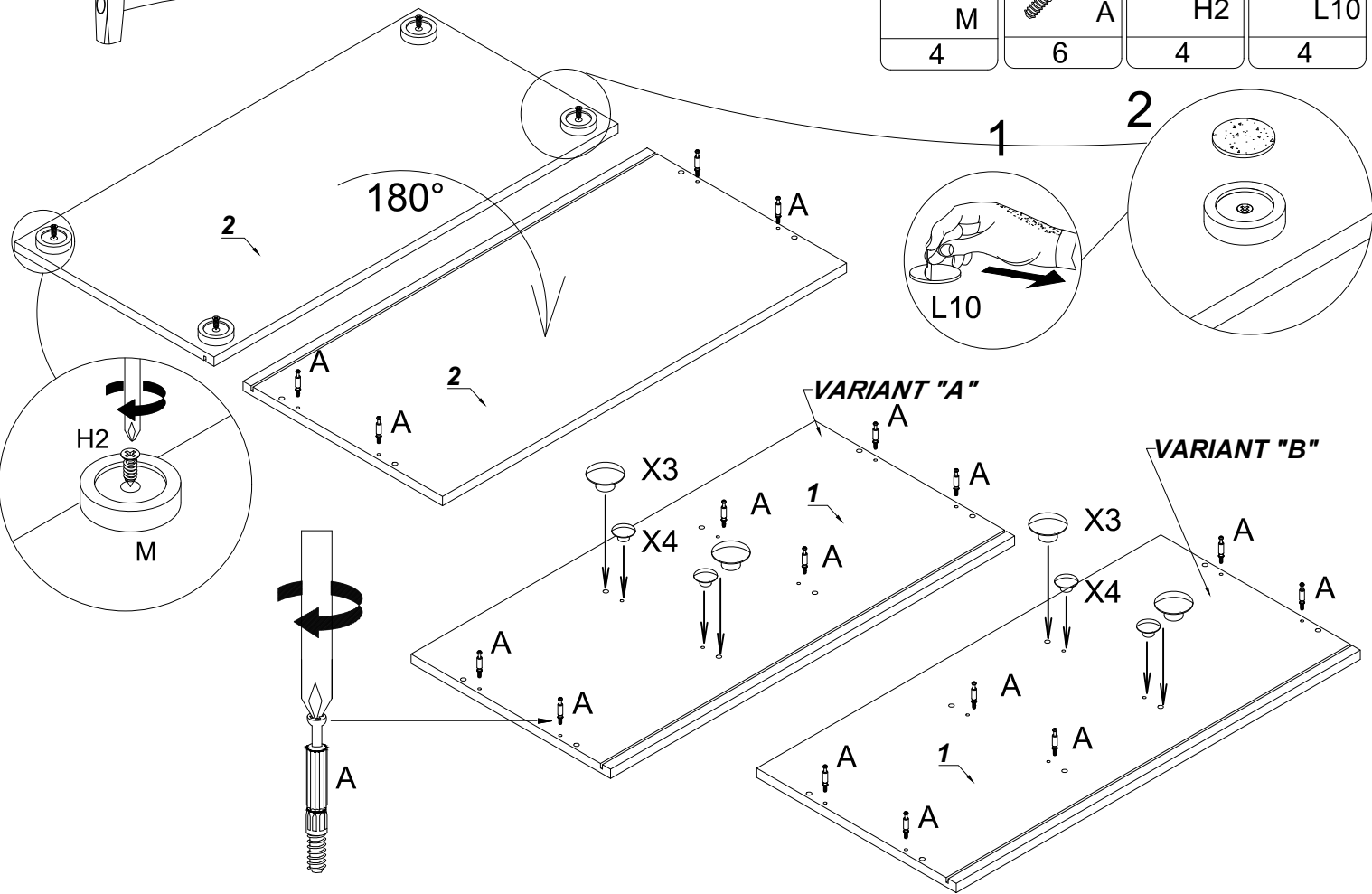

5

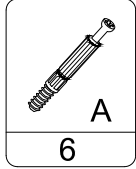
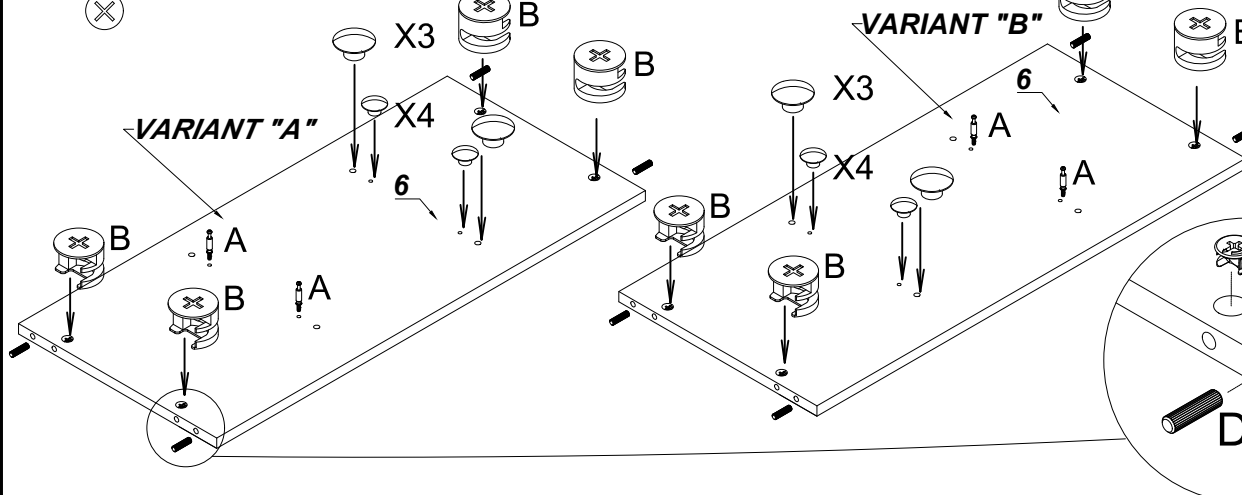
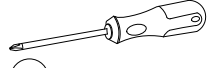

6

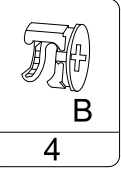

4

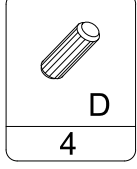

4

6

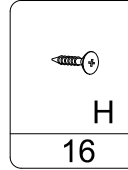
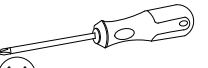

H

16

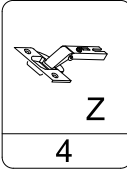

Z

4

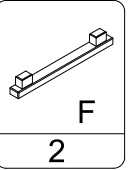

F

2

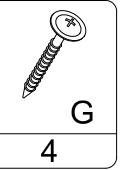

G

4

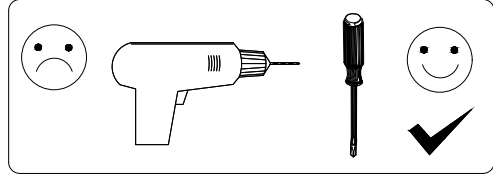
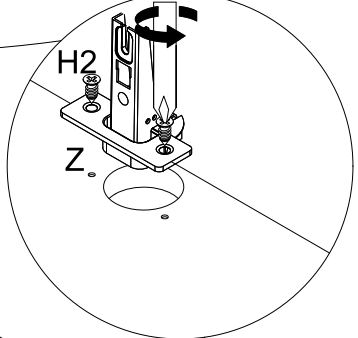
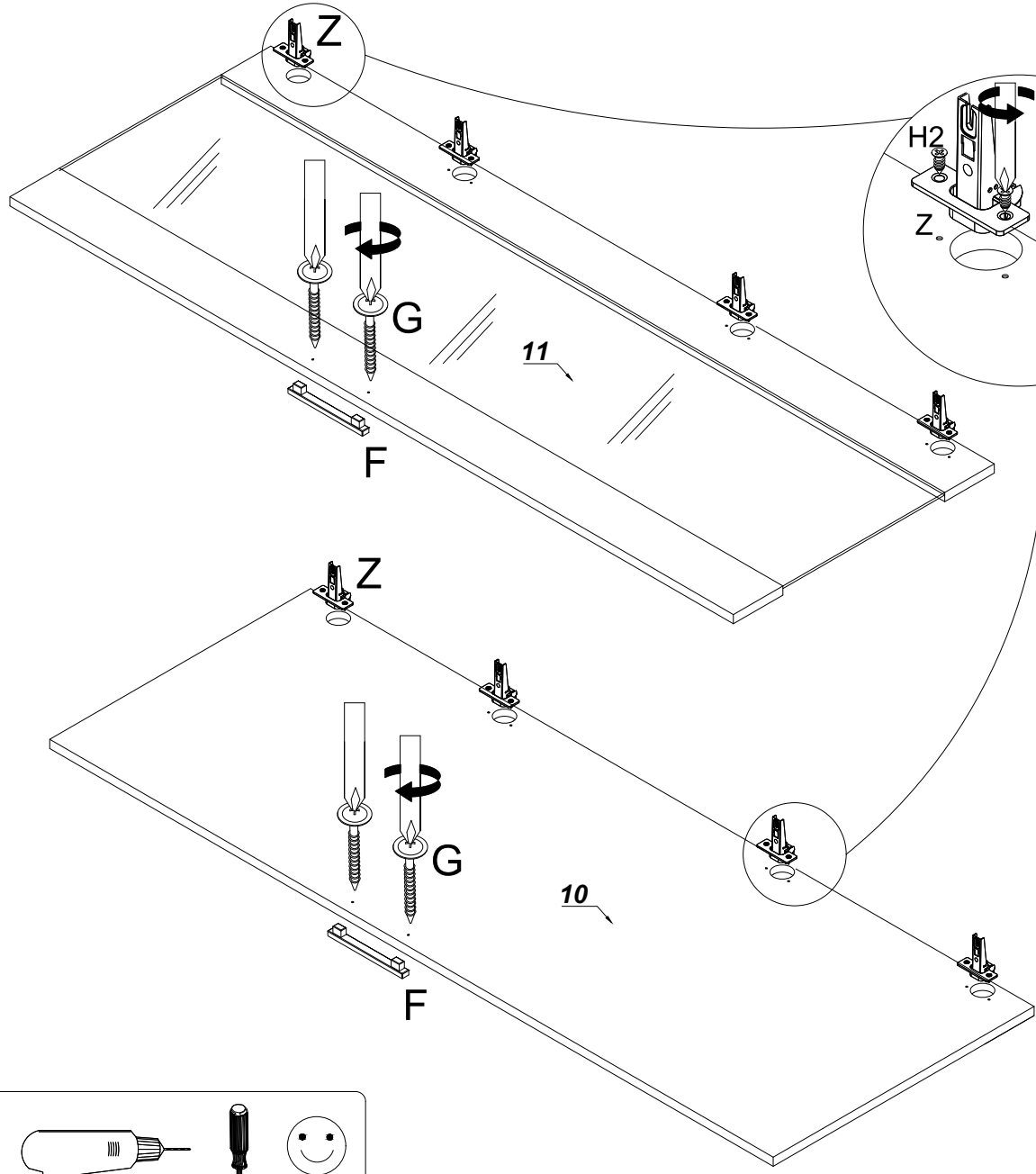

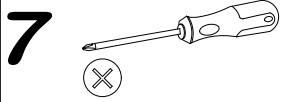

7

x2

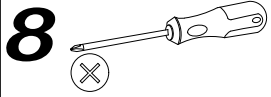
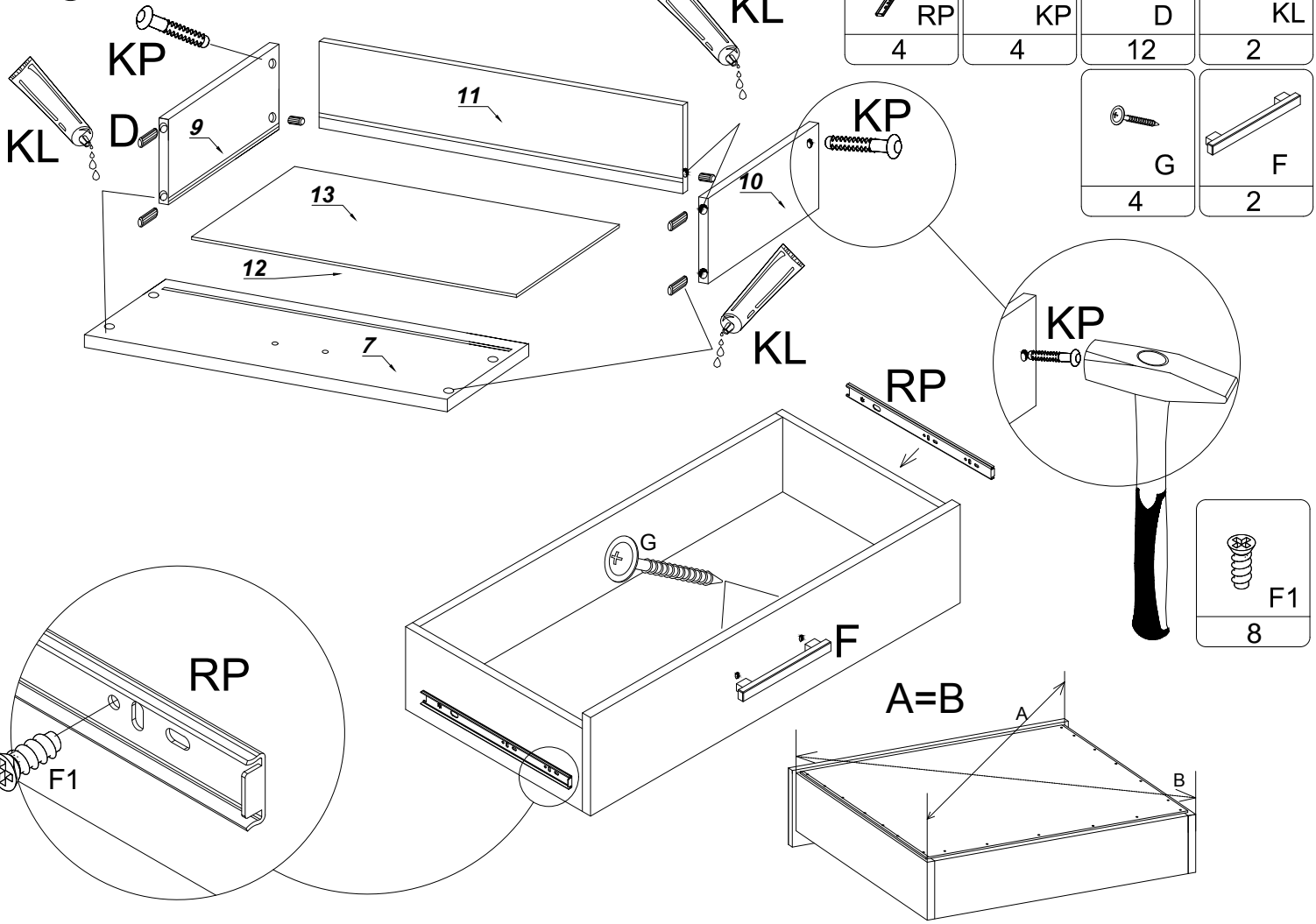

8

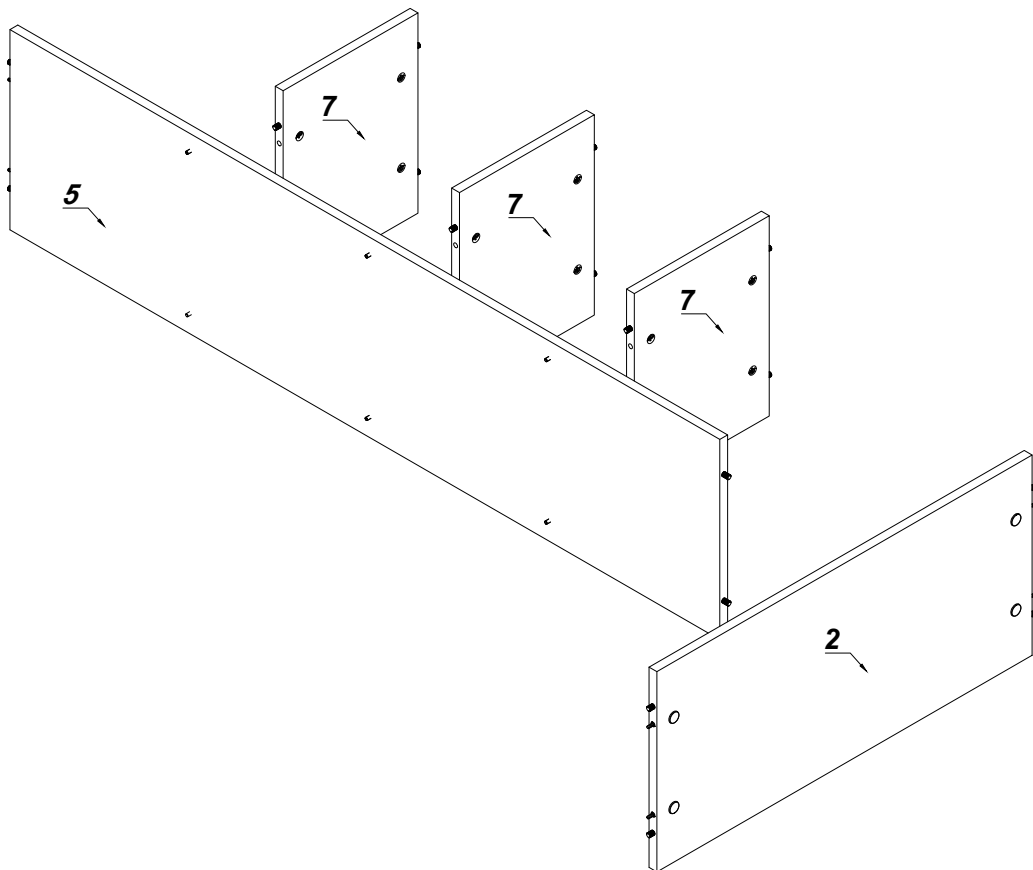

9

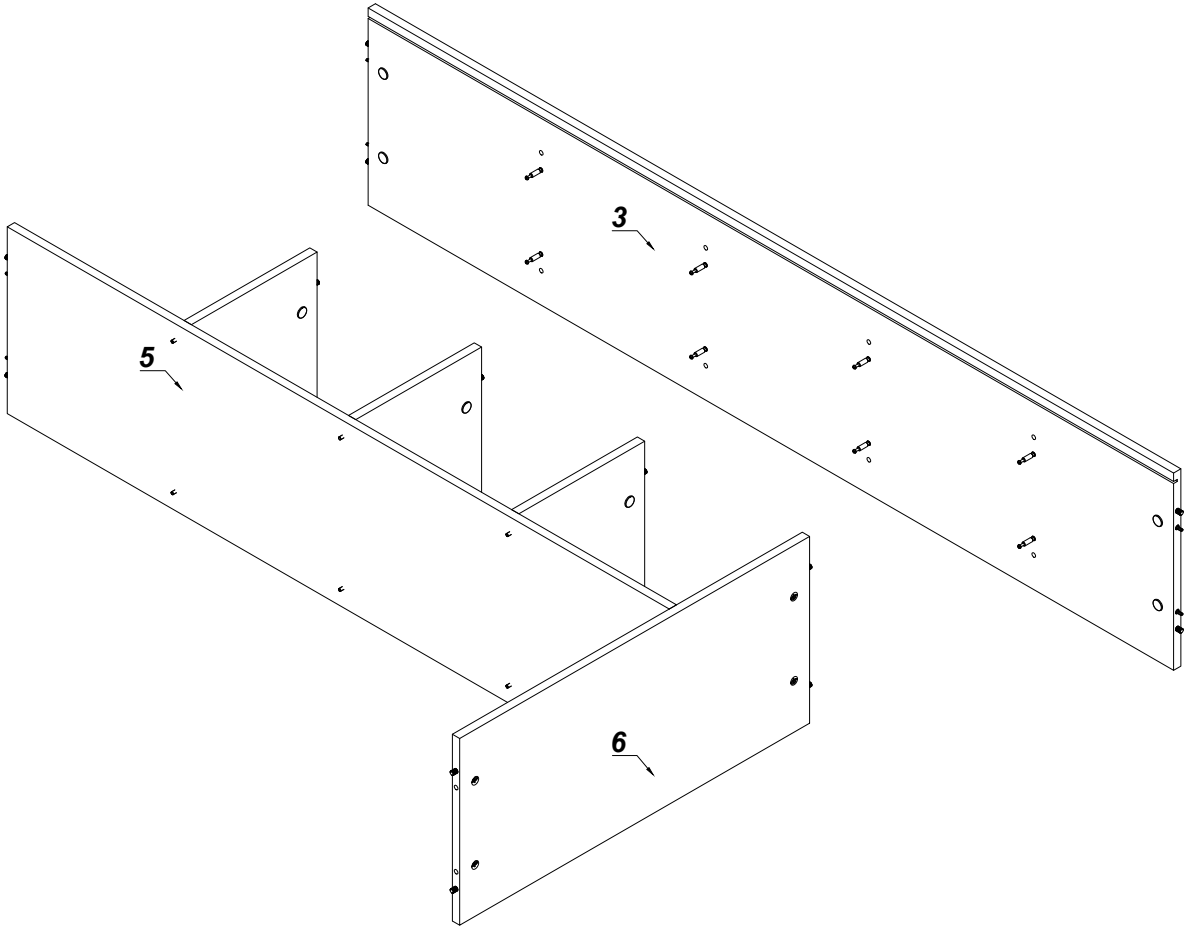
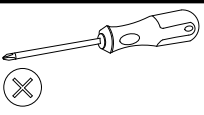

10

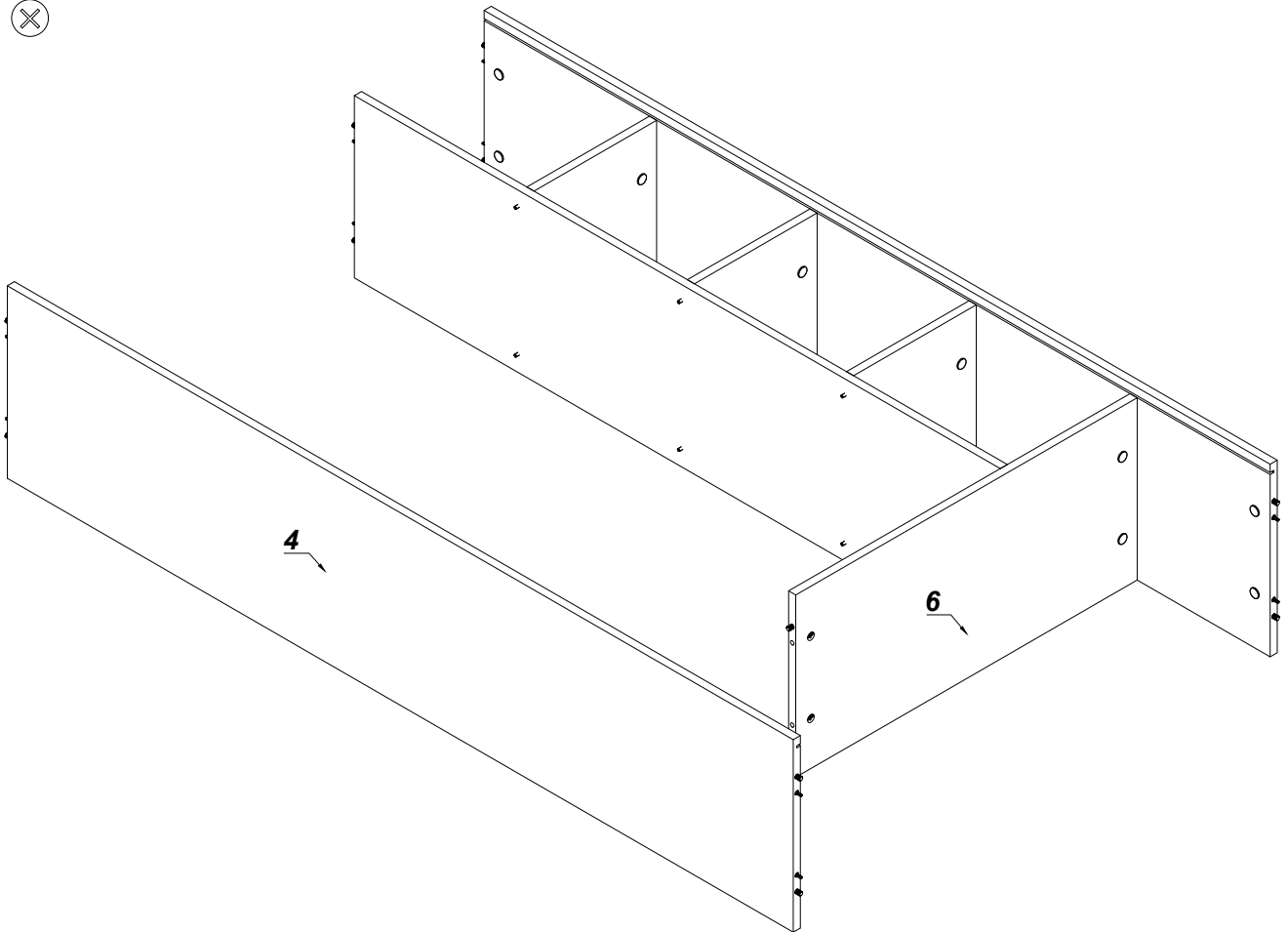
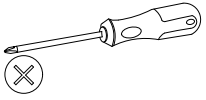

11

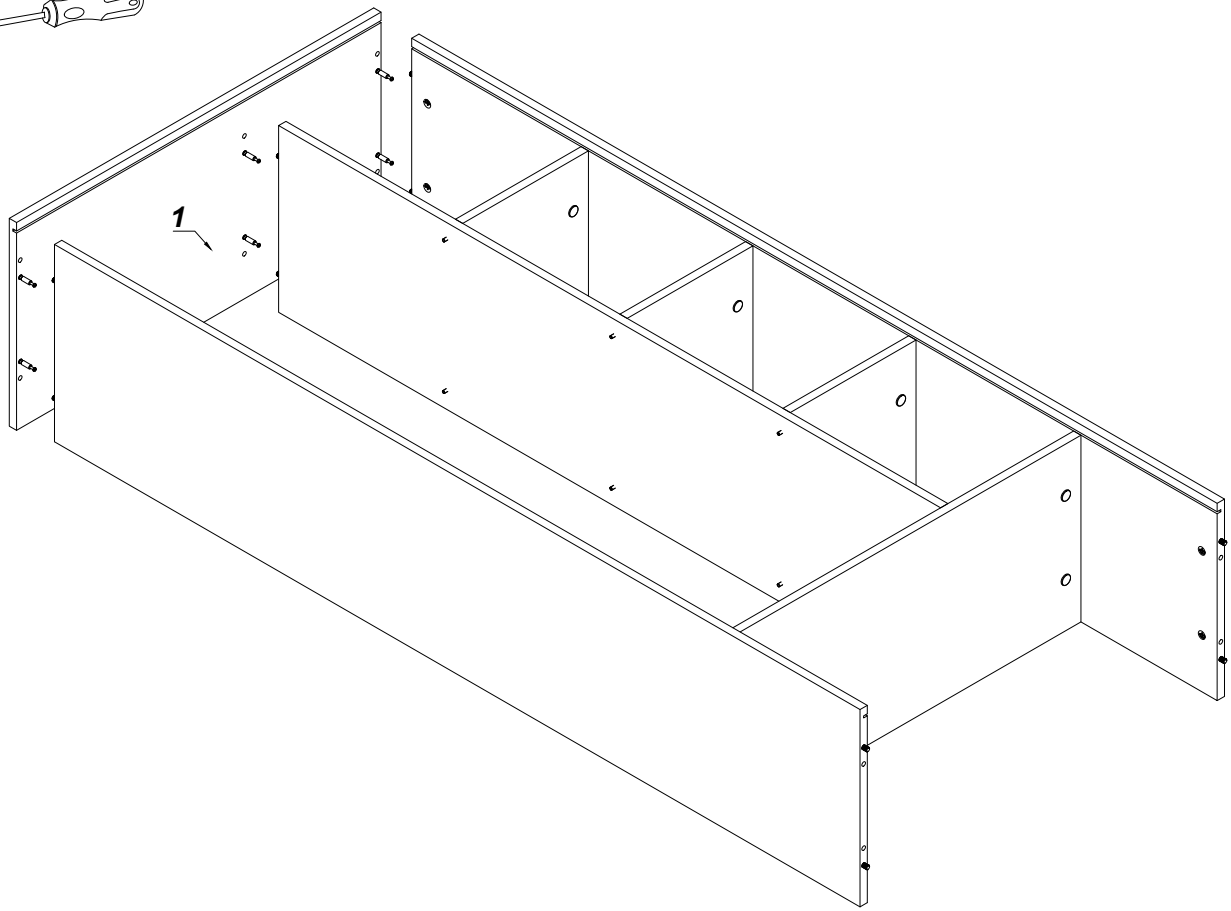

12

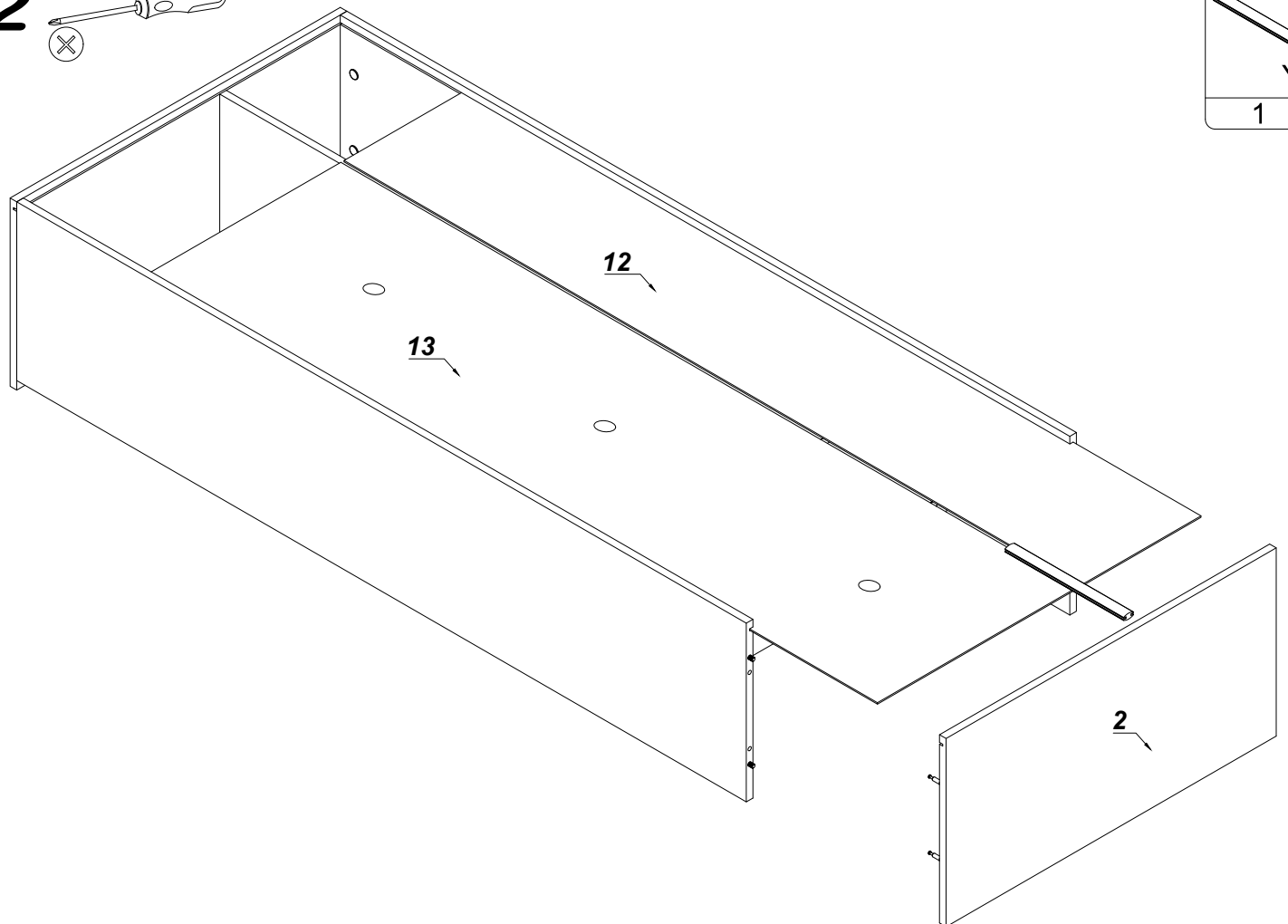

13

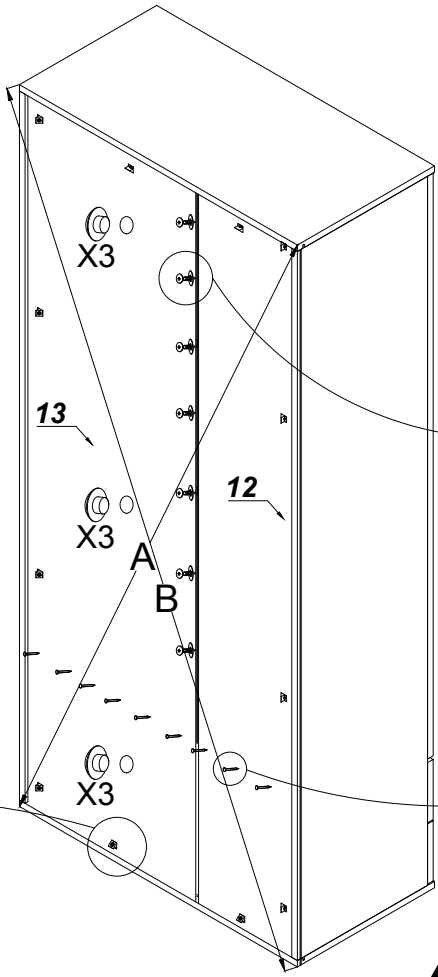
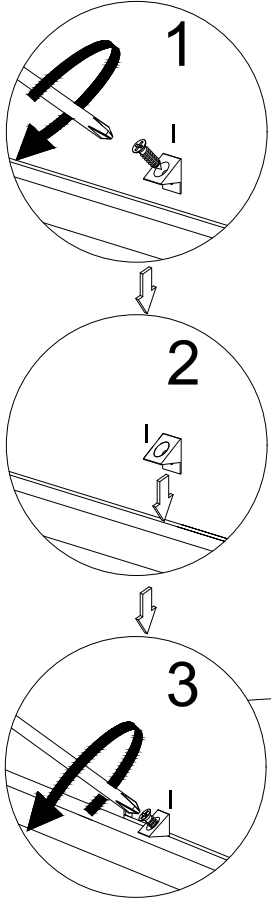
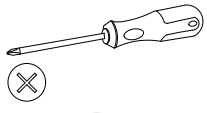

 H 7	 G1 7	 GW 20	 I 12
 X3 3			

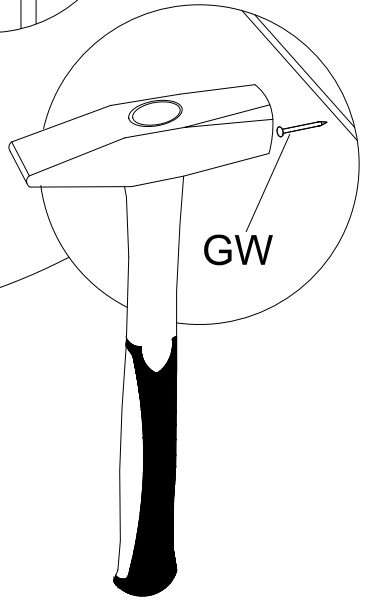
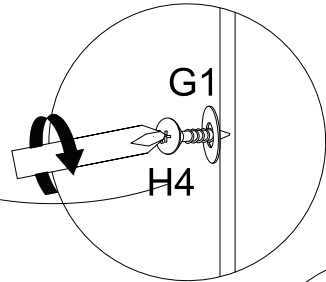

A=B

14

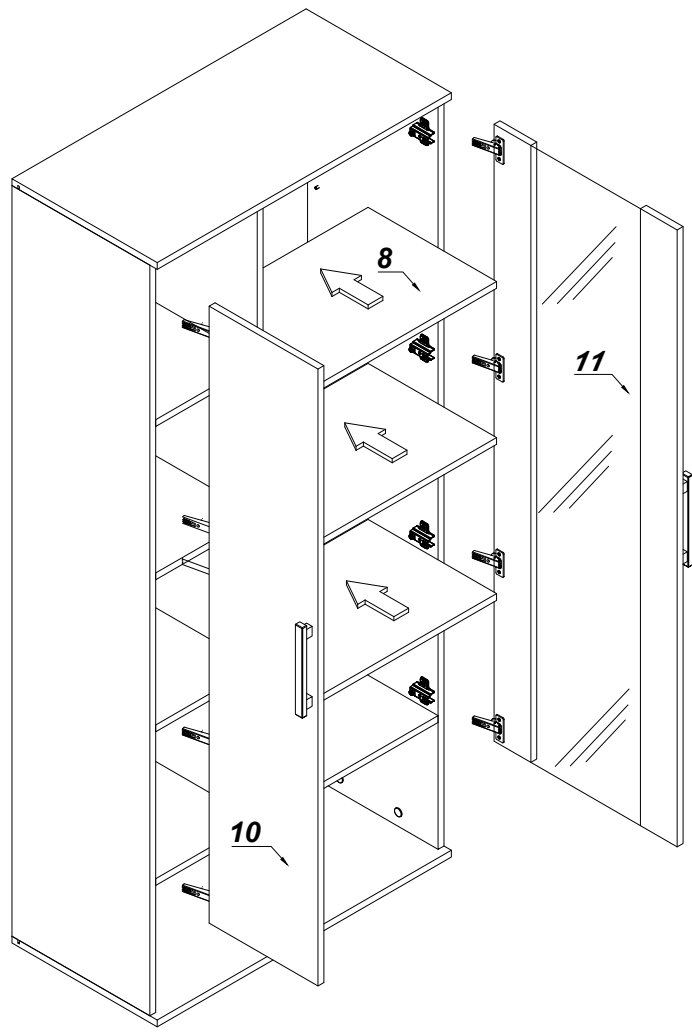
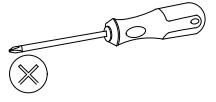

GUIDLINES FOR FURNITURE USE AND MAINTENANCE

GB

1. Furniture should be used in rooms which are dry and protected against the harmful influences of weather conditions.
2. Furniture should be assembled in accordance with the assembly manual.
3. Furniture should be assembled as close as possible to its intended final location.
4. While positioning the furniture make sure it is levelled
5. Furniture may be moved only by lifting and carrying it over when emptied of its contents. Pushing it over or pulling it along may ruin the furniture permanently. While carrying the furniture over it must be held by its vertical elements, i.e side panels or legs. Furniture cannot be held by its horizontal elements prone to destruction, i.e desktops drawer, etc..
6. Furniture should not be overloaded as this may ruin it permanently.
7. While using the furniture, the state of the connections between its elements should be checked if necessary.
8. Furniture surface must be cleaned only with furniture maintenance formulas.

