

# USER MANUAL

**KOOLMORE RESERVE**

**24 in. 1.6 Cu. Ft. Speed Oven  
Microwave, Convection, Sensor Cook,  
Airfry,**

**Models: KM-CWO24-AFSS**

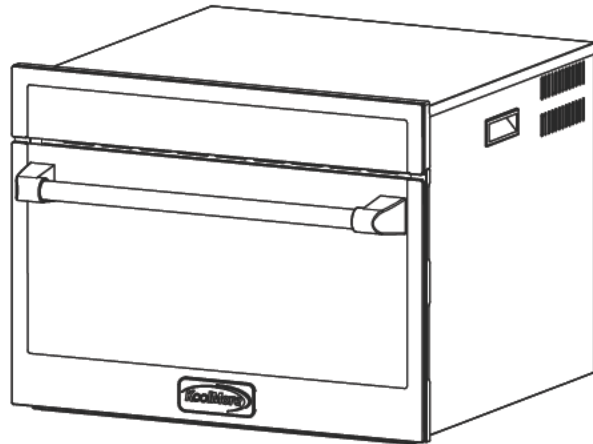

For any service related  
issues, please contact us:

 **718-576-6342**

 **support@koolmore.com**

Before using, please read the operating instructions carefully to  
ensure proper application and achieve satisfactory results.

**Stay informed with the latest information for your  
KoolMore Reserve Appliance.**

**If you need any assistance or have questions, our  
customer support team is here to help.**

# Contents

<b>Safety</b> .....	<b>4</b>
<b>Materials You Can &amp; Cant Use In Microwave Oven</b> .....	<b>11</b>
<b>Installation</b> .....	<b>12</b>
<b>Product Overview</b> .....	<b>17</b>
<b>Operation</b> .....	<b>20</b>
<b>Maintenance</b> .....	<b>32</b>
<b>Troubleshooting</b> .....	<b>35</b>
<b>Warranty</b> .....	<b>37</b>

# Safety

## SAVE THESE INSTRUCTIONS

### PRECAUTIONS TO AVOID POSSIBLE EXPOSURE TO EXCESSIVE MICROWAVE ENERGY

- Do not attempt to operate this oven with the door open since open door operation can result in harmful exposure to microwave energy. It is important not to defeat or tamper with the safety interlocks.
- Do not place any object between the oven front face and the door or allows soil or cleaner residue to accumulate on sealing surfaces.
- Do not operate the oven if it is damaged. It is particularly important that the oven door close properly and that there is no damage to the door (bent) hinges and latches (broken or loosened or door seals and sealing surfaces
- The oven should not be adjusted or repaired by anyone except properly qualified service personnel.

### IMPORTANT SAFETY INSTRUCTIONS

When using electrical appliances, basic precautions should be followed, including the following:

#### WARNING

To reduce the risk of burns, electric shock, fire, injury to persons or exposure to excessive microwave energy:

Read all instructions before using the appliance.

- Read and follow the specific "PRECAUTIONS TO AVOID POSSIBLE EXPOSURE TO EXCESSIVE MICROWAVE ENERGY" found above.
- This appliance must be grounded. Connect only to properly grounded outlet. See "GROUNDING INSTRUCTIONS" found on (Page 6).

Install or locate this appliance only in accordance with the provided installation instructions.

Some products such as whole eggs and sealed containers - for example, closed glass jars - are able to explode and should not be heated in this oven.

Use this appliance only for its intended use as described in the manual. Do not use corrosive chemicals or vapors in this appliance. It is not designed for industrial or laboratory use.

As with any appliance, close supervision is necessary when used by children.

Do not operate this appliance if it has a damaged cord or plug, if it is not working properly, or if it has been damaged or dropped.

This appliance should be serviced only by qualified service personnel. Contact nearest authorized service facility for examination, repair, or adjustment.

Do not cover or block any openings on the appliance.

Do not store this appliance outdoors. Do not use this product near water - for example, near a kitchen sink, in a wet basement, near a swimming pool, or similar locations.

Do not immerse cord or plug in water.  
Keep cord away from heated surfaces.  
Do not let cord hang over edge of table or counter.

**To reduce the risk of fire in the oven cavity:**

- Do not overcook food. Carefully attend appliance when paper, plastic, or other combustible materials are placed inside the oven to facilitate cooking.
- Remove wire twist-ties from paper or plastic bags before placing them in the oven.
- If materials inside the oven ignite, keep oven door closed, turn oven off, and disconnect the power cord, or shut off power at the fuse or circuit breaker panel.
- Do not use the cavity for storage purposes. Do not leave paper products, cooking utensils, or food in the cavity when not in use.
- Liquids, such as water, coffee, or tea are able to be overheated beyond the boiling point without appearing to be boiling. Visible bubbling or boiling when the container is removed from the microwave oven is not always present. THIS COULD RESULT IN VERY HOT LIQUIDS SUDDENLY BOILING OVER WHEN THE CONTAINER IS DISTURBED OR A UTENSIL IS INSERTED INTO THE LIQUID.
- To reduce the risk of injury to persons:
  - Do not overheat the liquid.
  - Stir the liquid both before and halfway through heating it.
  - Do not use straight-sided containers with narrow necks.

After heating, allow the container to stand in the microwave oven for a short time before removing the container to avoid the risk of burns. Use extreme care when inserting a spoon or other utensil into the container.

- Do not operate any heating or cooking appliance beneath the appliance.
- Do not mount unit over or near any portion of a heating or cooking appliance. (Exception: A microwave oven unit of not more than 3 cu. ft. capacity, mounted above and/or alongside another microwave oven.)
- Do not mount over a sink.
- Do not store anything directly on top of the appliance surface when the appliance is in operation.
- Oversized foods or oversized metal utensils should not be inserted in the microwave oven as they may create a fire or risk of electric shock.
- Do not clean with metal scouring pads. Pieces can burn off the pad and touch electrical parts involving a risk of electric shock.
- Do not use paper products when appliance is operated in the toaster mode.
- Do not store any materials, other than manufacturer's recommended accessories, in this oven when not in use.
- Do not cover racks or any other part of the oven with metal foil. This will cause overheating of the oven.
- This appliance has a non-stick surface. To avoid damage to the non-stick surface, use wooden or plastic utensils. Do not use metal utensils.

**To reduce the risk of injury to persons:**

- a) Use this appliance only for its intended use as described in the manual. Do not use corrosive chemicals or vapors in this appliance.
- b) Be careful not to pinch or crush the cord in the door or drawer.
- c) This appliance is not intended for use by persons (including children) with reduced physical, sensory or mental capabilities, or lack of experience and knowledge, unless they have been given supervision or instruction concerning use of the appliance by a person responsible for their safety.

- d) Children should be supervised to ensure that they do not play with the appliance.
- e) The appliance has a polarized plug (one blade is wider than the other). To reduce the risk of electric shock, this plug is intended to fit into a polarized outlet only one way. If the plug does not fit fully into the outlet, reverse the plug. If it still does not fit, contact a qualified electrician. Do not attempt to defeat this safety feature.
- f) If the power cord is damaged, it must be replaced by the manufacturer, its service agent or similarly qualified persons in order to avoid a hazard.
- g) The extension cord must be a grounding-type 3-wire cord.
- h) The longer cord should be arranged so that it will not drape over the countertop or tabletop where it can be pulled on by children or tripped over unintentionally.

## **⚠ WARNING**

- Do not use the microwave oven for storage. Do not leave paper products, cooking utensils, or food in the oven when not in use.
- Remove all materials from the oven before operating the microwave oven.
- If materials inside the oven ignite, keep oven door closed, turn oven off, and disconnect the power cord, or shut off power at the fuse or circuit breaker panel.

## **COMBINATION MICROWAVE OVENS**

- Oversized foods or oversized metal utensils should not be inserted in a microwave oven as they may create a fire or risk of electric shock.
- Do not clean with metal scouring pads. Pieces can burn off the pad and touch electrical parts involving a risk of electric shock.
- Do not use paper products when appliance is operated in the toaster mode.
- Do not store any materials, other than manufacturer's recommended accessories, in this oven when not in use.
- Do not cover racks or any other part of the oven with metal foil. This will cause overheating of the oven.

## **GROUNDING INSTRUCTIONS**

This appliance must be grounded. In the event of an electrical short circuit, grounding reduces the risk of electric shock by providing an escape wire for the electric current. This appliance is equipped with a cord having a grounding wire with a grounding plug. The plug must be plugged into an outlet that is properly installed and grounded.

## **⚠ WARNING**

Improper use of the grounding plug can result in a risk of electric shock. Consult a qualified electrician or service man if the grounding instructions are not completely understood, or if doubt exists as to whether the appliance is properly grounded. If it is necessary to use an extension cord, use only a 3-wire extension cord that has a 3-prong grounding plug, and a 3-slot receptacle that will accept the plug on the appliance. The marked rating of the extension cord should be equal to or greater than the electrical rating of the appliance.

## **DANGER - ELECTRIC SHOCK HAZARD**

*Touching some of the internal components can cause serious personal injury or death. Do not disassemble this appliance.*

## **⚠ WARNING**

## **ELECTRIC SHOCK HAZARD**

Improper use of the grounding plug can result in electrical shock. Do not plug into an outlet until the appliance is properly installed and grounded.

- a) This appliance should be serviced only by qualified service personnel. Contact nearest authorized service facility for examination, repair, or adjustment.
- b) Do not cover or block any openings on this appliance.
- c) Do not store this appliance outdoors. Do not use this product near water - for example, near a kitchen sink, in a wet basement, near a swimming pool, or similar locations.
- d) Do not immerse cord or plug in water.
- e) Keep cord away from heated surfaces.
- f) Do not let cord hang over edge of table or counter.

To reduce the risk of fire or electric shock:

- a) Do not operate any heating or cooking appliance beneath this appliance.
- b) Do not mount unit over or near any portion of a heating or cooking appliance. (Exception: A microwave oven unit of not more than 3 cu. ft. capacity, mounted above and/or alongside another microwave oven.)
- c) Do not mount over a sink.
- d) Do not store anything directly on top of the appliance surface when the appliance is in operation.

If a long or extension cord is used:

- a) The marked electrical rating of the cord set or extension cord should be at least as great as the electrical rating of the appliance.
- b) The extension cord must be a grounding-type 3-wire cord.
- c) The longer cord should be arranged so that it will not drape over the countertop or tabletop where it can be pulled on by children or tripped over unintentionally.

## **RADIO INTERFERENCE**

Operation of the microwave oven may cause interference to your radio, TV, or similar equipment. When there is interference, it may be reduced or eliminated by taking the following measures:

- Clean door and sealing surface of the oven.
- Reorient the antenna of radio or television.
- Relocate the microwave oven with respect to the receiver.
- Plug the microwave oven into a different outlet so that microwave oven and receiver are on different branch circuits.
- This equipment complies with FCC radiation exposure limits set forth for an uncontrolled environment. This equipment should be installed and operated with minimum distance 20cm between the radiator & your body.
- This device complies with CAN ICES-001 (B) / NMB-001 (B) & CAN ICES-003 (B) / NMB-003 (B).
- Operation is subject to the following two conditions: (1) This device may not cause interference, and (2) This device must accept any interference, including interference that may cause undesired

operation of the device.

### **This device complies with part 18 of the FCC Rules.**

This device complies with part 15 of the FCC Rules. Operation is subject to the following two conditions: (1) this device may not cause harmful interference, and (2) this device must accept any interference received, including interference that may cause undesired operation of the device.

*NOTE: This equipment has been tested and found to comply with the limits for a Class B digital device, pursuant to part 15 of the FCC Rules. These limits are designed to provide reasonable protection against harmful interference in a residential installation. This equipment generates, uses, and can radiate radio frequency energy and, if not installed and used in accordance with the instructions, may cause harmful interference to radio communications. However, there is no guarantee that interference will not occur in a particular installation. If this equipment does cause harmful interference to radio or television reception, which can be determined by turning the equipment off and on, the user is encouraged to try to correct the interference by one or more of the following measures:*

- *Reorient or relocate the receiving antenna.*
- *Increase the separation between the equipment and receiver.*
- *Connect the equipment into an outlet on a circuit different from that to which the receiver is connected.*
- *Consult the dealer or an experienced radio/TV technician for help.*
- *Changes or modifications not expressly approved by the party responsible for compliance could void the user's authority to operate the equipment.*

### **UTENSILS**

**⚠ CAUTION:** - Personal Injury Hazard

Tightly-closed utensils could explode. Closed containers should be opened and plastic pouches should be pierced before cooking.

See the instructions on "Materials you can use in microwave oven or to be avoided in microwave oven."

There may be certain non-metallic utensils that are not safe to use for microwaving. If in doubt, you can test the utensil in question following the procedure below.

Utensil Test:

Fill a microwave-safe container with 1 cup of cold water (250ml) along with the utensil in question. Cook on maximum power for 1 minute. Carefully feel the utensil. If the empty utensil is warm, do not use it for microwave cooking. Do not exceed 1 minute cooking time.

### **CAUSES OF DAMAGE**

**⚠ CAUTION:**

- Creation of sparks: Metal, e.g., a spoon in a glass, must be kept at least 2 cm from the oven walls and the inside of the door. Sparks could irreparably damage the glass on the inside of the door.
- Water in the hot cooking compartment: Never pour water into the hot cooking compartment. This will cause steam. The temperature change can cause damage.
- Moist food: Do not store moist food in the closed cooking compartment for long periods.
- Cooling with the appliance door open: This can lead to corrosion.
- Do not use the appliance to store objects: Only leave the cooking compartment to cool with the door closed. Do not trap anything in the appliance door. Even if the door is only slightly ajar, the fronts of adjacent units may be damaged over time.
- Heavily soiled: If the seal is very dirty, the appliance door will no longer close properly during operation. The fronts of adjacent units could be damaged. Always keep the seal clean.
- Operating the microwave without food: Operating the appliance without food in the cooking compartment can lead to overheating. The food must be placed in the cooking compartment before switching on the microwave. (An exception to this rule is a short crockery test.) (see the section "Microwave, suitable crockery").
- Using the appliance door for standing on or placing objects on: Do not stand or place anything on the open appliance door. Do not place ovenware or accessories on the appliance door.
- Transporting the appliance: Do not carry or hold the appliance by the door handle. The door handle cannot support the weight of the appliance and could break.
- Microwave popcorn: Never set the microwave power too high. Use a power setting no higher than 600 watts. Always place the popcorn bag on a ceramic plate. The disc may jump if overloaded.
- Liquid that has boiled over must not be allowed to run through the turntable drive into the interior of the appliance. Monitor the cooking process. Choose a shorter cooking time initially, and increase the cooking time as required.
- The oven should be cleaned regularly and any food deposits removed since they may explode.
- Failure to maintain the oven in a clean condition could lead to deterioration of the surface that could adversely affect the life of the appliance and possibly result in a hazardous situation.

### **For the Serviceman to be Serviced Only by Properly Qualified Service Personnel**

#### **▲ CAUTION:**

This device is to be serviced Only by Properly Qualified and Competent Personnel. Consult the Service Manual before servicing. When servicing the appliance, check the door seal and door seal area to ensure that they are not damaged, and that the appliance door closes properly and that there is no leakage of microwave energy, and correct any faults before the appliance is released for use.

#### **WARNING**

For continued protection against excessive radiation emission, replace only with the same type:

Primary Switch: TYPE KWA-102

Secondary Switch: TYPE KWA-103

Monitor Switch: TYPE KWA-101

Fuses: UL listed 20A for use in the appliance.

**PRECAUTIONS TO BE OBSERVED BEFORE AND DURING SERVICING TO AVOID POSSIBLE EXPOSURE TO EXCESSIVE MICROWAVE ENERGY:**

a. Do not operate or allow the oven to be operated with the door open.

b. Make the following safety checks on all ovens to be serviced before activating the magnetron or

other microwave energy generating device:

- (1) Operate the oven with the door open and check that the microwave energy does not exceed 5mW/cm<sup>2</sup> at any point 5cm or more from the external surface of the oven.
- (2) Check for proper operation of interlock systems that are incorporated within the door that prevent microwave emission should the door be opened.
- (3) Check for proper operation of oven door, including proper closing, sealing, and operation of safety interlocks.
- (4) Check for physical integrity of the gasket on the microwave oven door, and that the gasket has not become worn or damaged.
- (5) Check for proper grounding of the oven.
- (6) Check for any evidence of arcing or corona discharge within the oven cavity.
- (7) Check for any evidence of overheating or thermal damage to the oven or any of its components.

Before turning on the microwave power for any service test or inspection within the microwave generating compartments, check the magnetron, wave guide or transmission line, and cavity for proper alignment, integrity, and connections.

Any defective or misaligned components in the interlock, monitor, door seal, and the oven door should be corrected before the oven is released to the owner.

A microwave leakage check to verify compliance with the Federal Performance Standard should be performed on each oven prior to release to the owner.

## MATERIALS YOU CAN USE IN MICROWAVE OVEN

Utensils	Remarks
Browning dish	Follow manufacturer's instructions. The bottom of the browning dish must be at least 3/16 inch (5mm) above the turntable. Incorrect usage may cause the turntable to break.
Dinnerware	Microwave-safe only. Follow manufacturer's instructions. Do not use cracked or chipped dishes.
Glass jars	Heat-resistant oven glassware only. Make sure there are no metallic trims. Do not use cracked or chipped glassware.
Glassware	Microwave-safe only. Follow manufacturer's instructions. Do not use cracked or chipped dishes.
Oven cooking bags	Follow manufacturer's instructions. Do not close with metal tie. Make slits to allow steam to escape.
Paper plates and cups	Use for short-term cooking/warming only. Do not leave oven unattended while cooking.
Paper towels	Use to cover food for reheating and absorbing fat. Use with supervision for short-term cooking only.
Parchment paper	Use as a cover to prevent splattering and to wrap for steaming.
Plastic	Microwave-safe only. Follow manufacturer's instructions. Should be labeled "microwave safe." Some plastic containers soften as the food inside reaches boiling temperatures. These containers should be used for reheating and not for cooking.
Plastic wrap	Microwave-safe only. Use to cover food during cooking to retain moisture. Do not allow plastic wrap to touch food.
Thermometers	Microwave-safe only (meat and candy thermometers).
Wax paper	Use as a cover to prevent splattering and retain moisture.

## MATERIALS TO BE AVOIDED IN MICROWAVE OVEN

Utensils	Remarks
Aluminum tray	May cause arcing. Transfer food into microwave-safe dish.
Food carton with metal handle	May cause arcing. Transfer food into microwave-safe dish.
Metal or metal-trimmed utensils	Metal shields the food from microwave energy. Metal trim may cause arcing.
Metal twist ties	May cause arcing and could cause a fire in the oven.
Paper bags	May cause a fire in the oven.
Plastic foam	Plastic foam may melt or contaminate the liquid inside when exposed to high temperature.
Wood	Wood will dry out when used in the microwave oven and may split or crack.

# Installation

## IMPORTANT INFORMATION

Electrical connection with plug (not for some models, subject to our products)

The appliance may be fitted with a plug, and may only be connected to a properly installed, earthed socket.

Only a qualified electrician who takes the relevant regulations into account may install the socket or replace the connecting cable.

If the appliance is to be replaced, follow the installation instructions. An all-pole isolating switch must be present on the installation side with a contact gap of at least 3 mm. Contact protection must be ensured by the installation.

Electrical connection without plug (not for some models, subject to our products)

The appliance may be fitted with a plug, and may only be connected to a properly installed, earthed socket.

Only a qualified electrician who takes the relevant regulations into account may install the socket or replace the connecting cable.

If the appliance is to be replaced, follow the installation instructions. An all-pole isolating switch must be present on the installation side with a contact gap of at least 3 mm. Contact protection must be ensured by the installation.

Connect the appliance,

The appliance must be connected in accordance with the installation instructions.

Connect the earth wire

The appliance must be earthed.

Important:

Do not connect the appliance to the power supply using an extension cord.

The appliance must not be operated with an external timer or remote control system.

Green and yellow wire (Earth) Earth (E)

Brown wire (Live) (L)

Blue wire (Neutral) (N)

Great Britain and Australia:

Do not connect the appliance to the power supply using an extension cord.

The appliance must not be operated with an external timer or remote control system.

Power supply specifications:

AC 220-240 V, 50 Hz or 110-127 V, 60 Hz

If the appliance is to be installed in accordance with the installation instructions, it must be connected by an authorized electrician.

When the appliance is installed, protection must be provided against accidental contact in the future.

## **BEFORE YOU BEGIN**

### **Tools and parts needed:**

- Phillips head screwdriver
- Flat-head bit
- Electric drill and drill bit
- Scissors or utility knife
- Tape measure

### **Parts included:**

- Microwave oven
- Phillips head screws

### **Power Requirements:**

- The outlet must be properly grounded in accordance with all applicable codes.

*Note: If the power supply cord is damaged, it must be replaced by the manufacturer, its service agent, or similarly qualified persons in order to avoid a hazard.*

## **CHECKLIST FOR INSTALLATION**

Use this checklist to verify that you have completed each step of the installation process. This can help you avoid mistakes.

Refer to detailed instructions for each step in the sections following this checklist.

1. Before installing the appliance, be sure to verify the cabinet dimensions are correct for your appliance and that the required electrical connections are present. Make sure the electrical conduit provided on the appliance is able to reach to the point of connection.
2. Remove all packaging material and bottom packaging. Remove any foam or cardboard from inside the appliance to ensure proper operation.
3. Move the appliance into place. Carefully move the appliance into the space provided, ensuring it fits properly without excessive force.
4. Level the appliance. Use the leveling legs, if provided, to ensure the appliance is stable and level.
5. Connect the appliance to the power supply. Follow the electrical connection instructions carefully. Ensure the appliance is properly grounded.

6. Secure the appliance to the cabinet. Use the provided screws or brackets to secure the appliance in place to prevent movement.
7. Test the appliance. After installation, perform a test run to ensure the appliance is functioning correctly and there are no leaks or issues.

Always read and follow the complete installation instructions contained in this manual.

## INSTALLATION INSTRUCTIONS

### GENERAL CABINET REQUIREMENTS

- Minimum clearance required between the side of the appliance and an adjacent wall or cabinet door when installed at the end of a cabinet run: A minimum of 14 inches is required.
- Toe kick height: A minimum of 3 inches is required for proper ventilation.
- Cabinet opening dimensions: The cabinet opening must be large enough to accommodate the appliance, including space for ventilation.
- Depth of cabinet: The depth of the cabinet must be deep enough to accommodate the appliance.
- Width of cabinet: The width of the cabinet must be wide enough to accommodate the appliance.

### Installation Instructions:

- Prepare the cabinet: Ensure the cabinet is clean, dry, and free of any debris. Check that the cabinet dimensions match the appliance requirements.
- Remove packaging: Remove all internal packaging materials from the appliance.
- Place the appliance: Carefully slide the appliance into the prepared cabinet space. Ensure it is level and properly aligned.
- Secure the appliance: Use the provided screws or brackets to secure the appliance to the cabinet. Ensure it is firmly in place.
- Connect to power: Follow the electrical connection instructions. Ensure the appliance is properly grounded and connected to the correct voltage.
- Test the appliance: After installation, test the appliance to ensure it is working correctly. Check for any unusual noises or signs of malfunction.

### Notes:

*Always ensure there is adequate ventilation. Do not block air vents.*

*Keep the appliance clean, especially the interior, to prevent odors and maintain efficiency.*

*Refer to the user manual for specific operating instructions and safety guidelines.*

### DIMENSIONS

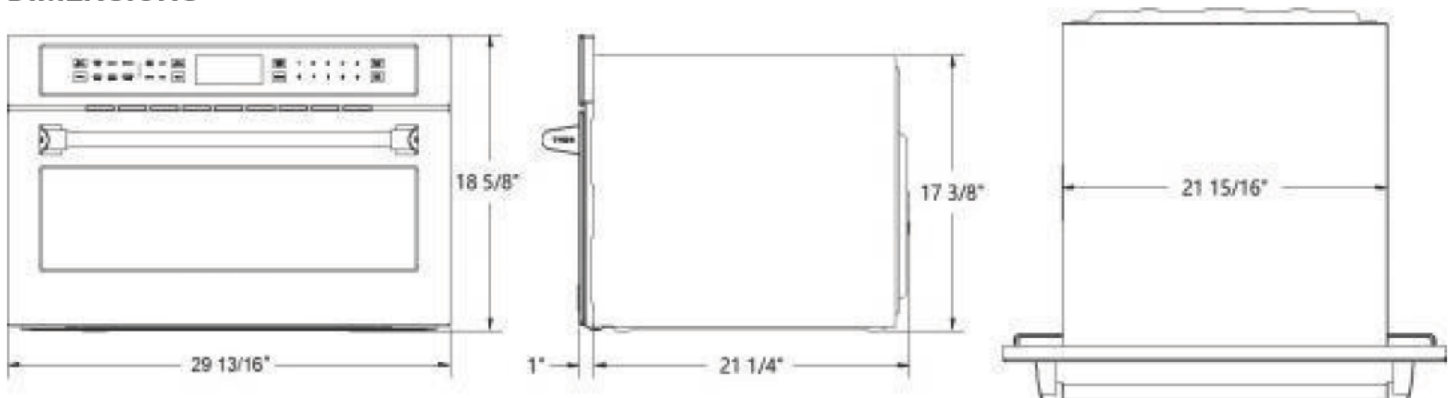

## BUILT-IN

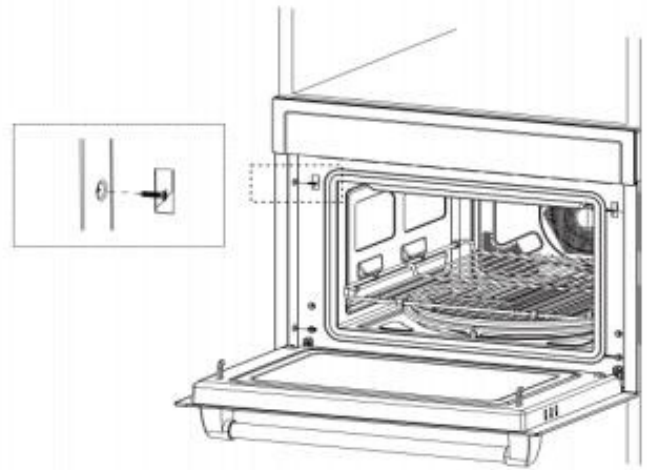
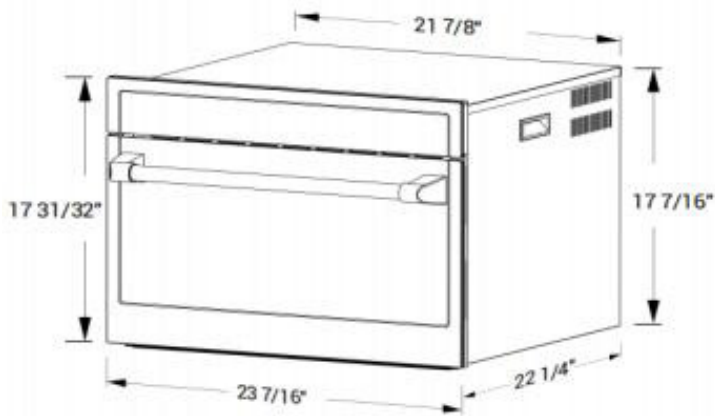

## STANDARD INSTALLATION

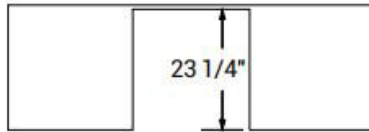

Top view

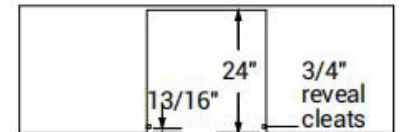

Top view

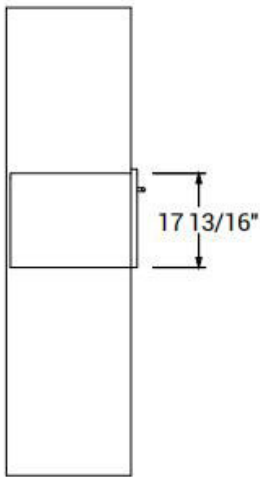

Side view

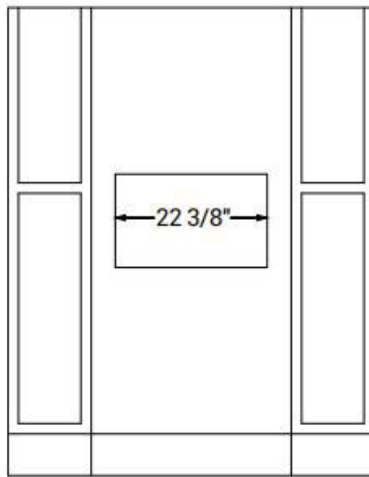

Front view

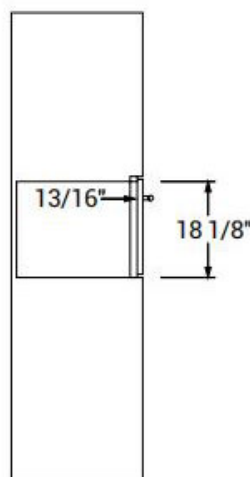

Side view

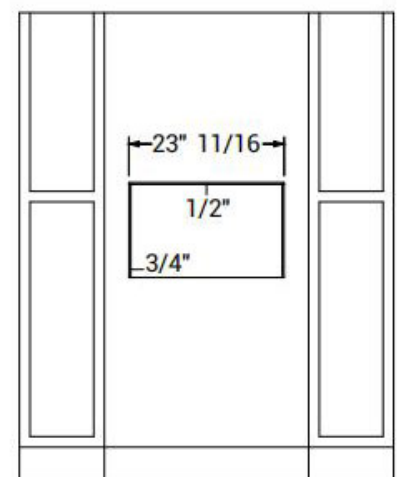

Front view

Cutout width : 22 3/8"      Cutout height : 17 13/16"  
Cutout depth : 23 1/4"

Cutout width : 23 11/16"      Cutout height : 18 1/8"  
Cutout depth : 24"

## VENTILATED CABINET

- This appliance is only intended to be fully fitted in a kitchen. This appliance is not designed to be used as a tabletop appliance or inside a cupboard.
- The fitted cabinet must not have a back wall behind the appliance.
- A gap of at least 1 3/4" (44.5 mm) must be maintained between the wall and the base or back panel of the unit above.
- The fitted cabinet must have a ventilation opening of 38 3/4 in<sup>2</sup> in the base. To achieve this, cut back the base panel or fit a ventilation grill.
- Ventilation slots and intakes must not be covered.
- The safe operation of this appliance can only be guaranteed if it has been installed in accordance with these installation instructions.
- The units into which the appliance is fitted must be heat-resistant up to 194°F.
- *Note: There should be a minimum 1/16" gap above the oven.*
- *Note: The vent should not be directly against the enclosed space, such as ceiling mezzanine, sound insulation wall mezzanine.*

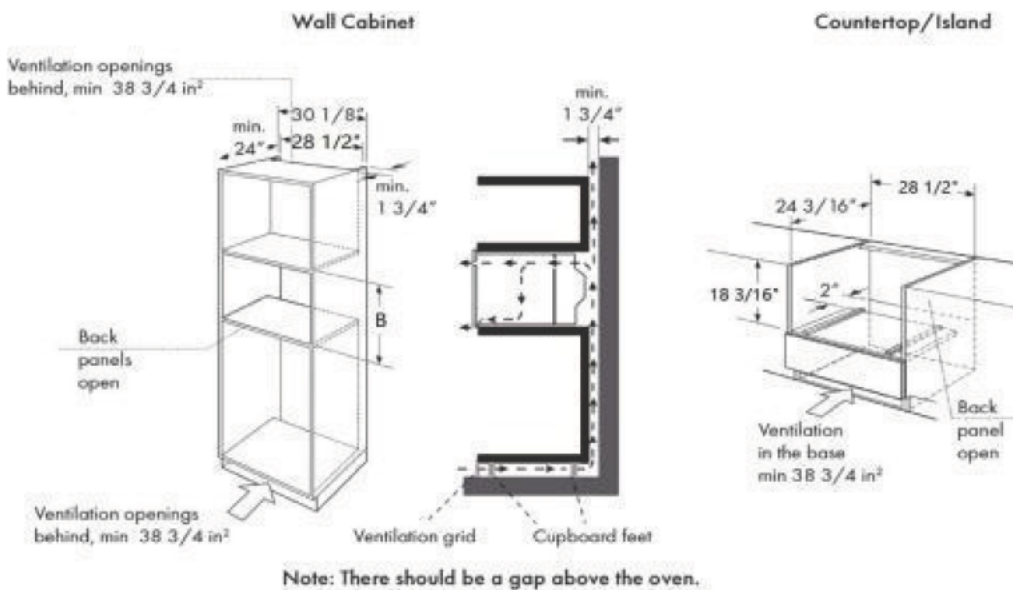

- Carefully push the microwave into the cabinetry, making sure that it is in the center.
- Do not kink the electrical cable.
- Open the door and fasten the microwave with the screws that were supplied.

### ⚠ WARNING

The gap between the worktop and the appliance must not be closed by additional battens.

### MOUNT TO CABINET

NOTE: The appliance is heavy. It is advisable to install it with a second person.

### ⚠ NOTICE:

Before installing the appliance, be sure to verify the cabinet dimensions and electrical connections.

Fully insert the appliance and center it. Do not kink the electrical cable. Screw the appliance into pre-drilled holes in the cabinetry.

# Product Overview

## YOUR NEW APPLIANCE

Use this section to familiarise yourself with your new appliance. The control panel and the individual operating controls are explained. You will find information on the cooking compartment and the accessories.

## CONTROL PANEL



## DISPLAY SCREEN

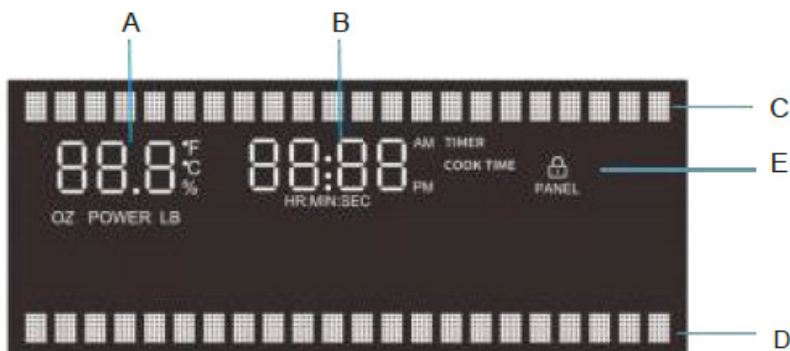

A: Microwave cavity display B: Time of cooking / timer / clock display C: Function prompt area  
D: Parameter setting prompt area E: Control lock display

## TOUCH KEYS AND DISPLAY

The touch keys are used to set the various additional functions. On the display, you can read the values that you have set.

Symbol	Function
Lock (3 sec.)	Activate/deactivate child lock
Settings	System settings
Soften/Melt	Select Soften/Melt programs
Sensor Cook	Select Sensor Cook programs
Defrost	Select Auto Defrost programs
Sensor Reheat	Select Sensor Reheat programs
Popcorn	Cook popcorn
Beverage Center	Heat beverages
Conv Mode	Select Convection modes
Air Fry	Select AirFry cook programs

Symbol	Function
Broil	Set Broil mode
Pizza	Select pizza programs
Timer/Off (3 sec.)	Set the time of timer
Clock	Set time of day
START (30 sec.)	Confirm entered values/Start cooking mode/ Add 30 seconds
CANCEL	Cancel the programs/turn the appliance off
0-9	Use the number keys to enter customized values
Power Level	Set power level for microwave operation
Cook Time	Set cooking time

## PARAMETER ADJUSTMENT

Use the adjusting keys to set the parameters

Parameter	Function
Power Level	Set the microwave power level.
Cook Time	Set the time of cooking.

## COOLING FAN

Your appliance has a cooling fan. The cooling fan switches on during operation. The hot air escapes above the door. The cooling fan continues to run for a certain time after operation.

Caution!

Do not cover the ventilation slots. Otherwise, the appliance will overheat.

Notes

- The appliance remains cool during microwave operation. The cooling fan will still switch on. The fan may run on even when microwave operation has ended.
- Condensation may appear on the door window, interior walls and floor. This is normal and does not adversely affect microwave operation. Wipe away the condensation after cooking.

## ACCESSORIES

### Turntable

As a surface for the wire rack.

Food which particularly requires a lot of heat from underneath can be prepared directly on the turntable. The turntable can turn clockwise or anti-clockwise.

Place the turntable on the drive in the centre of the cooking compartment. Ensure that it is properly fitted.

- Never use the microwave without the turntable.
- The turntable can withstand max. 11 LBS.
- The turntable must turn when using all types of heating.



## Baking rack

For grilling, e.g. steaks, sausages and for toasting bread.

We recommend using the rack together with the baking tray when cooking items on the rack which might drip.

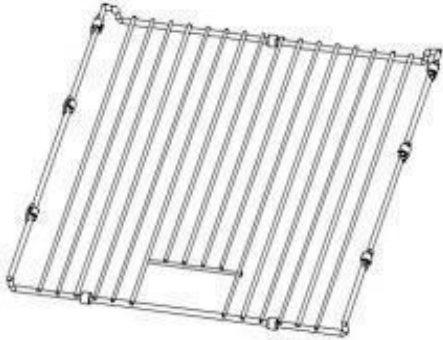

## Ceramic Tray

For microwave cooking and convectional cooking. You can place food, like a popcorn bag, potatoes, microwave pizza or defrost, directly on the ceramic tray.

The ceramic tray will get hot during the convection cooking. Place the ceramic tray on the top of the metal tray turntable. The ceramic tray can remain in the oven for all cooking modes, unless "Bake on Metal Tray" is required.

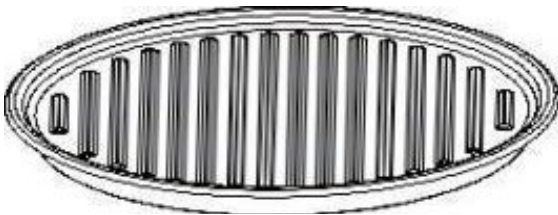

Note:

*Type and quantity of accessories is subject to actual demand.*

# Operation

## BEFORE USING THE APPLIANCE FOR THE FIRST TIME

Here you will find everything you need to do before using your oven to prepare food for the first time. First read the section on .IMPORTANT SAFETY INSTRUCTIONS.

### Setting the clock

When power is first supplied to the oven, the timer display will flash "12:00" and "Clock setting" will appear on the display . Enter the time by touching the number keypads. Then touch START to allow operation.proceed as follow:

1. Touch START to set clock or touch Clock,
2. Choose 12 or 24 hours system according to the prompts,
3. Enter the correct time using the number keys. Example: To set the clock to 12:30 type in 1 2 3 0,
4. Touch START to confirm is complete setting.

### Note

When power is first supplied to the oven, you can directly press any key to enter the settings without setting the clock.

### Heating up the oven

To remove the new oven smell, heat up the appliance when it is empty and closed. One hour with Convection at 350F is ideal. Ensure that no packaging remnants have been left in the oven cavity.

1. Touch Conv Mode and then enter the numbers to select Baked goods ,according to the prompts,
2. Enter the numbers 3 5 0 with the number keys,and then press START to confirm temperature is complete setting,
3. Enter the cooking time numbers 6 0 with the number keys,
4. Touch SATART to start cooking.

The oven light turns on and the appliance starts heating.

### Cleaning the accessories

Before you use the accessories for the first time, clean them thoroughly with hot soapy water and a soft dish cloth.

## SETTING THE OVEN

### Settings

The oven has additional settings which can be accessed and adjusted using the settings button. They remain in the control's memory until changed.

## How to use:

1. Touch Settings. The oven display will scroll through the various options.
2. Touch the number keypad for the specific option to toggle the function setup. Use a following chart as a guide.

Option	Code	Function Description
Temp Units	1	Set temperature unit
Sound	2	Key sound switch
Error Code Query	3	Query for error codes that have occurred
Version	4	Version information query
Display Mode	5	Set oven demo mode
Shabbat	6	Set Shabbat mode. (The cooking time can be set within 74 hours) Sabbath mode disables the oven lights (the oven light will not turn on when the door is opened), all sounds (the control will not beep when the screen is pressed), Convection modes, Broil modes, Warm, Proof, and all time functions. Shabbat mode can only be used with traditional Bake. This feature conforms to Jewish Shabbat requirements.
Factory Reset	7	Restore factory setting

## Timer/Off(3 sec.)

The Timer can be set in minutes and seconds or hours and minutes and counts down the set time.

How to set timer:

1. Touch Timer/Off(3 sec.).The oven display will scroll through the various options.
2. Touch number keypad “1” to select HR:MIN or “2” to select MIN:SEC.
3. Touch number keypads to set a length of the timer.
4. Touch START.

The oven display will count down the timer. If both cooking time and timer are set, only display the time of the cooking. If enabled, end-of-cycle tones will sound, It ends automatically in one minute, or hold Timer/Off(3sec.) for 3 seconds to clear the display and stop the reminder tones.

*NOTE: The Timer does not start or stop the oven.*

Lock Control:

To Lock Control:

Touch Lock (3 sec.). The oven control is locked when a lock icon appears in the display.

To Unlock Control:

Hold Lock for 3 seconds. 3-2-1 appears in the display, and then the oven is unlocked, and the lock icon is removed.

**NOTE:** The Control Lock shuts down the control panel keypads to avoid unintended use of the oven. The Control Lock will remain set after a power failure, if set before the power failure occurs. When the control is locked, only the CANCEL, Lock keypads will function.

## COOKING MODE

There are various ways in which you can set your oven. Here we will explain how you can select the

desired type of heating and temperature or grill setting. You can also select the oven cooking time for each dish. Please refer to the section on Setting the time-setting options.

### Soften/Melt:

Soften and Melt functions may be used to soften or melt your food. Times and cooking powers have been preset for a number of food types.

### How to use Soften and Melt:

1. Touch Soften/Melt. The oven display will scroll through the various options.
2. Touch number keypad "1" to select soften function or "2" to select melt function.
3. Touch number keypad to select food type from the Soften Chart or Melt Chart.
4. Touch number keypads to enter quantity (weight or sticks).
5. Touch START to start cooking.

The oven display will count down the soften or melt time. When the stop time is reached, the oven will shut off automatically, and "Soften complete" or "Melt complete" will appear in the display. If enabled, end-of-cycle tones will sound, it ends automatically in one minute, or touch CANCEL or open the door to clear the display and stop the reminder tones.

### Soften Chart

Food	Code	Quantity	Preparation
Butter		10.5-2 Sticks	Unwrap and place in microwave-safe container.
Margarine		20.5-2 Sticks	Unwrap and place in microwave-safe container.
Ice Cream	3	16, 32, 64 oz (454, 907 g, or 1.8 kg)	
Cream Cheese	4	3 or 8 oz (85 g or 227 g)	Unwrap and place in microwave-safe container.

### Melt Chart

Food	Code	Quantity	Preparation
Butter	1	0.5-2 Sticks	Unwrap and place in microwave-safe container.
Margarine	2	0.5-2 Sticks	Unwrap and place in microwave-safe container.
Chocolate	3	2, 4, 6, 8 oz (57, 113, 170, 227 g)	Cut squares into small pieces or use chips. Place in microwave-safe container.
Cheese	4	8 or 16 oz (227 or 454 g)	Cut into small pieces and place in microwave-safe container.
Marshmallows	5	5 or 10 oz (142 or 283 g)	Place in microwave-safe container.

### Sensor Cook

You can select two sensor cooking modes. Sensor cooking allows you to cook many of your favorite foods without selecting cooking times and power levels. The microwave oven automatically determines the required cooking time for each food item.

Using the Sensor Cook function, a sensor automatically adjusts for the cook time and power level. The microwave oven display will show the "Maximum Time Remaining" prompt and the time count-

down once the sensor identifies the cooking duration.

If the microwave oven door is opened during a sensor function, the microwave oven will turn off, and any additional operations will be canceled.

How to use Sensor Cook:

Touch Sensor Cook. The oven display will scroll through the various options.

Touch number keypad to select food type from the Sensor Cook Chart.

Touch number keypads to enter quantity (weight or cups).

Touch START to start cooking.

The oven display will count down the Sensor Cook time. When the stop time is reached, the oven will shut off automatically, and "Sensor cooking complete" will appear in the display.

If enabled, end-of-cycle tones will sound, it ends automatically in one minute, or touch CANCEL or open the door to clear the display and stop the reminder tones.

### Sensor Cook Chart

Food	Code	Quantity
Baked Potato	1	1-4 potatoes (8-32 oz)
Pierce skin with a fork. Do not cover. After cooking, allow to stand wrapped in foil for 5 minutes.		
Ground Meat	2	8-24 oz (0.5-1.5 lbs)
After cooking, allow to stand, covered, for 3-4 minutes.		
Vegetable	3	4-16 oz (0.25-1 lbs)
No water is needed if vegetables have just been washed. Add 2 tablespoons water per 8 ounces of fresh vegetables.		
Fish/Seafood	4	8-20 oz (0.5-1.25 lbs)
Roll thin edges underneath. Arrange in a ring around microwavable dish.		
Frozen Entree	5	10-20 oz
Follow package instructions for venting, cutting plastic film, etc.		

### Sensor Reheat

The sensor reheat feature lets you reheat dinner plates or casseroles(8-16 oz) for your cooking convenience.

How to use Sensor Reheat:

1. Touch Sensor Reheat .

2. Touch START to start cooking.

The oven display will count down the Reheat time.

When the stop time is reached, the oven will shut off automatically and "Reheat complete" will appear in the display.

If enable, end-of-cycle tones will sound, It ends automatically in one minute, or touch CANCEL or

open the door to clear the display and stop the reminder tones.

#### Notes

- Cover with vented plastic wrap or wax paper.
- Reheat food on a microwaveable dinner plate.

### Sensor Reheat Cooking Suggestions

Food	Directions	Quantity
Pasta	Cover plate with lid or vented plastic wrap. If food is not hot enough after heating with the Reheat feature, continue heating using manual time and power level setting. Stir foods once before serving. Contents: - Pasta: Canned spaghetti and ravioli, refrigerated foods	1-4 servings

### Defrost

The Defrost feature can be used, or the microwave oven can be manually set to defrost by using 30% cook power.

For optimal results, food should be 0°F (-18°C) or colder when defrosting.

For optimal results, food should be 0°F (-18°C) or colder when defrosting.

Shallow packages will defrost more quickly than deep blocks.

Separate food pieces as soon as possible during or at the end of the cycle for more even defrosting.

Foods left outside the freezer for more than 20 minutes or frozen ready-made food should not be defrosted using the Defrost feature, but should be defrosted manually.

Use small pieces of aluminum foil to shield parts of food such as chicken wings, leg tips, and fish tails.

Times and cooking powers have been preset for defrosting a number of food types.

Manual Defrost requires that a cook time and power level be entered if using other than 30% cook power.

How to use Defrost:

Touch Defrost. The oven display will scroll through the various options.

Touch number keypad to select food type from the Defrost Chart (Except Manual Defrost).

Touch number keypads to enter weight.

Touch START to start cooking.

The oven display will count down the Defrost time. For better results, a preset standing time is included in the defrosting time. This may make the defrosting time seem longer than expected. When the stop time is reached, the oven will shut off automatically and "Defrost complete" will appear in the display.

If enabled, end-of-cycle tones will sound, it ends automatically in one minute, or touch CANCEL or open the door to clear the display and stop the reminder tones.

## How to use Manual Defrost:

1. Touch Defrost .The oven display will scroll through the various options
2. Touch number keypad “6” to select Manual Defrost.
3. Touch number keypads to set a length of time to defrost. Time can be set up to 99 minutes and 99 seconds.
4. The default power level is 30%. To change power level, touch Power Level and then enter the desired power level. See the Power Level Chart.
5. Touch START to start cooking.  
 The oven display will count down the Defrost time. For better results, a preset standing time is included in the defrosting time.  
 When the stop time is reached, the oven will shut off automatically and “Defrost complete” will appear in the display.  
 If enable, end-of-cycle tones will sound, It ends automatically in one minute, or touch CANCEL or open the door to clear the display and stop the reminder tones.

## Defrost Chart

Food	Code	Weight
Poultry	1	0.1 - 6.6 lbs
Meats	2	0.1 - 6.6 lbs
Fish	3	0.1 - 6.6 lbs
Bread	4	0.1 - 2.0 lbs
Juice	5	6, 12, or 16 oz
Manual	6	Default power level 30%

## Defrost Preparation Chart

<b>Poultry</b>	
Chicken: whole and cut up	Place in microwave-safe baking dish, chicken breast side up. Remove giblets from whole chicken.
Cornish hens	
Turkey: breast	
<b>Meats</b>	
Beef: ground, steaks, roast, stew	The narrow or fatty areas of irregular shaped cuts should be shielded with foil before defrosting. Do not defrost less than 1/4 lb (113 g) or two 4 oz (113 g) patties. Place all meats in microwave-safe baking dish.
Lamb: stew and chops	
Pork: chops, ribs, roasts, sausage patties	
<b>Fish</b>	
Fillets, Steaks, Whole, Shellfish	Place in microwave-safe baking dish.

## Popcorn

Do not leave oven unattended while popping corn. Popcorn may ignite and cause fire.

How to use popcorn mode:

The appliance must be turned off.

Touch Popcorn. The oven display will scroll through the various options.

Touch number keypads to select the weight code from popcorn chart.

Touch START to start cooking.

The oven display will count down the popcorn time.

When the stop time is reached, the oven will shut off automatically and "Popcorn complete" will appear in the display.

If enabled, end-of-cycle tones will sound. It ends automatically in one minute, or touch CANCEL or open the door to clear the display and stop the reminder tones.

NOTE: Follow the instructions provided by the microwave popcorn manufacturer.

### Popcorn Chart

Code	Weight
1	1.5 oz
2	2.5 oz
3	3.5 oz

## Beverage Center

The beverage feature heats 0.5 to 2 cups of a beverage.

How to use Beverage Center:

1. Touch Beverage Center. The oven display will scroll through the various options.
2. Touch number keypads to select the weight code from beverage center chart.
3. Touch START to start cooking.

The oven display will count down the Beverage Center time.

When the stop time is reached, the oven will shut off automatically and "Cooking complete" will appear in the display.

If enabled, end-of-cycle tones will sound. It ends automatically in one minute, or touch CANCEL or open the door to clear the display and stop the reminder tones.

### Beverage Center Chart

Code	Weight
1	0.5 Cups
2	1.0 Cups
3	1.5 Cups
4	2.0 Cups

## Conv Mode

Convection cooking uses the convection element, the broil element and the fan. Hot air is circulated throughout the oven cavity by the fan. The constantly moving air surrounds the food to heat the outer portion quickly.

The convection function may be used to cook small amounts of food on a single rack.

Always use the convection grid placed on turntable or baking tray.

Do not cover turntable or convection grid or baking tray with aluminum foil.

Do not use light plastic containers, plastic wrap, or paper products. All heatproof cookware or metal utensils can be used in convection cooking. Round pizza pans are excellent for convection cooking. Use convection cooking for items such as souffles, breads, cookies, angel food cakes, pizza, and most meats and fish.

All Convection Mode functions require preheating before use. Place food in microwave oven after preheating is complete.

How to use Conv Mode:

Touch Conv Mode. The oven display will scroll through the various options.

Touch number keypad to select food type from the Conv Mode Chart.

## Convection Mode Instructions

1. Touch number keypads to enter temperature.
2. Touch number keypads to set a length of time for Convection cooking.
3. Touch START to start cooking.

The oven will start to preheat until preheat is complete. A beep will sound, and the oven display will count down the Convection Mode time.

When the stop time is reached, the oven will shut off automatically, and "Cooking complete" will appear in the display.

If enabled, end-of-cycle tones will sound. It ends automatically in one minute, or touch CANCEL or open the door to clear the display and stop the reminder tones.

Tips: You can touch START directly without entering the time of cooking, after setting the cooking temperature.

The oven will work for the maximum safe time, at which time the cooking time will not be displayed.

## Convection Mode Chart

Option	Code	Food	Cook Time	Oven Temp
Baked goods	1	Biscuits, Breads: quick and yeast, Cakes and Cookies, Casseroles: including frozen entrees and soufflés, Fish, Baked potatoes	0:01-1:00 hr	175-450 °F
Meats	2	Chicken: whole and pieces, Meat loaf, Roasts: pork, beef, and ham	0:01-1:00 hr	175-450 °F
		(Turkey and large poultry are not included because their cook times vary.)		
Other foods	3	Convenience foods: french fries, nuggets, fish sticks, pizza, Pies: fruit and custard	0:01-1:00 hr	175-450 °F

## **Air Fry**

Air Fry is a special, no-preheat, cooking mode that is designed to produce foods with a crispier exterior than traditional oven cooking.

- Only use broil-safe cookware when using Air Fry mode.
- A dark sheet pan is recommended. A dark pan promotes better browning and crisping.
- Oven baking baskets and baking grids can also be used. A sheet pan should be placed on the rack below the foods to catch any drippings when using a baking basket.

### **How to use Air Fry:**

1. Touch Air Fry.
2. Touch number keypads to enter temperature. The temperature can be set between 175 °F and 450 °F.
3. Touch number keypads to set a length of time to Air Fry. Time can be set up to 1 minute and 10 hours.
4. Touch START to start cooking.

The oven display will count down the Air Fry time.

When the stop time is reached, the oven will shut off automatically and “Cooking complete” will appear in the display.

If enabled, end-of-cycle tones will sound. It ends automatically in one minute, or touch CANCEL or open the door to clear the display and stop the reminder tones.

Tips: You can touch START directly without entering the time of cooking, after setting the cooking temperature. The oven will work for the maximum safe time, at which time the cooking time will not be displayed.

- For cooking fresh or homemade foods, spread the oil over a larger area more evenly, crisping up the food more effectively.

## **Broil**

When the crisper pan is used with microwaves, it is like a frying pan or griddle, ideal for French toast, burgers, eggs, stir-frying, and sautéing. The default temperature is 400 °F; the default cooking time is 3 hours. The oven temperature and cook time can not be set.

How to use Broil:

1. Touch Broil.
2. Touch START to start cooking.

The oven display will count down the Broil time, but not display.

When the stop time is reached, the oven will shut off automatically and “Cooking complete” will appear in the display.

If enabled, end-of-cycle tones will sound. It ends automatically in one minute, or touch CANCEL or open the door to clear the display and stop the reminder tones.

## **Pizza**

- Check pizza before minimum time; pizza may cook faster compared to a traditional oven.
- For fresh pizza, use a pizza paddle for sliding the pizza on and from the metal turntable.
- If using a pizza paddle, sprinkle the paddle liberally with cornmeal for ease in transferring the dough to the metal turntable.
- Maximum size is 12 inches for fresh and frozen pizzas.
- Avoid using a pizza stone as it can damage the oven.
- The metal turntable can be used for cutting pizza into slices. Remove the turntable from the oven after the pizza is baked.

### **How to use Pizza:**

1. Touch Pizza.
2. Touch number keypads to enter temperature. The temperature can be set between 175 °F and 450 °F.
3. Touch number keypads to set a length of time for cooking. Time can be set up to 1 minute and 10 hours.
4. Touch START to start cooking.

The oven will start to preheat until preheat is complete. A beep will sound, and the oven display will count down the Pizza time if you set it.

When the stop time is reached, the oven will shut off automatically and “Cooking complete” will appear in the display. If enabled, end-of-cycle tones will sound. It ends automatically in one minute, or touch CANCEL or open the door to clear the display and stop the reminder tones.

Tips: You can touch START directly without entering the time of cooking, after setting the cooking temperature. The oven will work for the maximum safe time, at which time the cooking time will not be displayed.

## **OTHER SETTINGS**

### **Power Level**

Many recipes for microwave cooking specify which cooking power to use by percent, name, or number. For example, 70% = 7 = Medium-High.

Use the following chart as a general guide for the suggested cooking power of specific foods.

### **How to use Power Level:**

1. Touch Power Level.
2. Touch number keypads to enter power level from microwave cooking power chart.
3. Touch number keypads to set a length of time to microwave cooking. Time can be set up to 1 second and 99 minutes.
4. Touch START to start cooking.

The oven display will count down the Microwave cooking time.

When the stop time is reached, the oven will shut off automatically and “Cooking complete” will appear in the display. If enabled, end-of-cycle tones will sound. It ends automatically in one minute, or touch CANCEL or open the door to clear the display and stop the reminder tones.

### Microwave Cooking Power Chart

Percent	Number	Use
100%, High	10	Quick heating convenience foods and foods with high water content, such as soups, beverages, and most vegetables.
90%	9	Cooking small, tender pieces of meat, ground meat, poultry pieces, and fish fillets. Heating cream soups.
80%	8	Heating rice, pasta, or casseroles. Cooking and heating foods that need a cook power lower than high. For example, whole fish and meat loaf.
70%, Medium-High	7	Reheating a single serving of food.
60%	6	Cooking sensitive foods such as cheese and egg dishes, pudding, and custards. Cooking non-stirrable casseroles, such as lasagna.
50%, Medium	5	Cooking ham, whole poultry, and pot roasts. Simmering stews.
40%	4	Melting chocolate. Heating bread, rolls, and pastries.
30%, Medium-Low, Defrost	3	Defrosting bread, fish, meats, poultry, and precooked foods.
20%	2	Softening butter, cheese, and ice cream.
10%, Low	1	Taking chill out of fruit.

### Cook Time

How to use Cook Time:

1. Touch Cook Time. The default power level is 100%. If you need other power levels, you can touch Power Level to set.
2. Touch number keypads to set a length of time to microwave cooking. Time can be set up to 1 second and 99 minutes.
3. Touch START to start cooking.

The oven display will count down the Microwave cooking time.

When the stop time is reached, the oven will shut off automatically and “Cooking complete” will appear in the display. If enabled, end-of-cycle tones will sound. It ends automatically in one minute, or touch CANCEL or open the door to clear the display and stop the reminder tones.

START/+30 sec.

The START/+30 sec. keypad controls 2 separate functions for the built-in microwave: Start and Add 30 seconds.

## START

The START/+30 sec. keypad begins any upper or single oven cooking function once enough data has been entered and the door is closed.

After enough data has been entered and the door is closed, "Press START to confirm" will appear on the oven display as a reminder. If the Start keypad is not touched within 30 seconds after touching another keypad, the oven display will return to the inactive mode and the programmed function will be canceled.

If cooking is interrupted by opening the door, touching START/+30 sec. after the door is closed again will resume the preset cycle.

+30 sec.

Touching START/+30 sec. when the microwave oven is off will start 30 seconds of cook time at 100% power. Touching START/+30 sec. while the microwave oven is operating will add cook time to the current cycle by 30 seconds. Multiple seconds can be added by repeatedly touching START/+30 sec. (manually enter cooking time modes only).

### Update Temperature

1. Touch number keypad to update temperature.
2. Touch START to start cooking with the new settings.

### Update Cooking Time

1. Touch Cook Time.
2. Touch number keypad to update the time of cooking.
3. Touch START to start cooking with the new settings.

### Update Power Level

1. Touch Power Level.
2. Touch number keypad to update the power level of cooking.
3. Touch START to start cooking with the new settings.

### Heating Food

#### **WARNING**

Risk of scalding!



There is a possibility of delayed boiling when a liquid is heated. This means that the liquid reaches boiling temperature without the usual steam bubbles rising to the surface. Even if the container only moves a little, the hot liquid can suddenly boil over and spatter. When heating liquids, always place a spoon in the container. This will prevent delayed boiling.

# Maintenance

## CARE AND CLEANING

With careful care and cleaning, your microwave oven will retain its looks and remain in good order. We will explain here how you should care for and clean your appliance correctly.

**WARNING: Risk of electric shock!**

Penetrating moisture may cause electric shock. Do not use any high-pressure cleaners or steam cleaners.

**WARNING: Risk of burns!**

Never clean the appliance immediately after switching off. Let the appliance cool down.

**WARNING: Risk of serious damage to health!**

Microwave energy may escape if the cooking compartment door or the door seal is damaged. Never use the appliance if the cooking compartment door or the door seal is damaged. Contact the after-sales service.

**NOTE:**

- Slight differences in color on the front of the appliance are caused by the use of different materials, such as glass, plastic, and metal.
- Shadows on the door panel which look like streaks are caused by reflections made by the oven light.
- Unpleasant odors, e.g., after fish has been prepared, can be removed very easily. Add a few drops of lemon juice to a cup of water. Place a spoon into the container as well, to prevent delayed boiling. Heat the water for 1 to 2 minutes at maximum microwave power.

### Cleaning agents

To ensure that the different surfaces are not damaged by using the wrong cleaning agent, observe the information in the table. Do not use:

- Sharp or abrasive cleaning agents,
- Metal or glass scrapers to clean the glass in the appliance door,
- Metal or glass scrapers to clean the door seal,
- Hard scouring pads and sponges,
- Cleaning agents with high concentrations of alcohol.

Wash new sponge cloths thoroughly before use.

Allow all surfaces to dry thoroughly before using the appliance again.

Area	Cleaning agents
Appliance front	Hot soapy water: Clean with a dish cloth and dry with a soft cloth. Do not use glass cleaners or metal or glass scrapers for cleaning.
Appliance front with stainless steel	Hot soapy water: Clean with a dish cloth and dry with a soft cloth. Remove flecks of limescale, grease, starch and albumin (e.g., egg white) immediately. Corrosion can form under such residues. Special stainless steel cleaning agents can be obtained from the after-sales service or from specialist shops. Do not use glass cleaners or metal or glass scrapers for cleaning.
Cooking compartment	Hot soapy water or a vinegar solution: Clean with a dish cloth and dry with a soft cloth. If the oven is very dirty: Do not use oven spray or other aggressive oven cleaners or abrasive materials. Scouring pads, rough sponges and pan cleaners are also unsuitable. These items scratch the surface. Allow the interior surfaces to dry thoroughly.
Recess in cooking compartment	Damp cloth: Ensure that no water seeps through the turntable drive into the appliance interior.
Wire racks	Hot soapy water: Clean using stainless steel cleaning agent or in the dishwasher.
Door panels	Glass cleaner: Clean with a dish cloth. Do not use a glass scraper.
Seal	Hot soapy water: Clean with a dish cloth, do not scour. Do not use a metal or glass scraper for cleaning.

## CLEANING AND MAINTENANCE

### WARNING

Be sure the entire appliance has cooled and grease has solidified before attempting to clean any part of the appliance.

### Cleaning Guide

For best performance and for safety reasons, keep the oven clean inside and outside. Take special care to keep the inner door panel and oven front frame free of food and grease build-up. Never use abrasive scouring powder or pads on the microwave. Wipe the microwave oven inside and out with a soft cloth and warm (not hot) mild detergent solution. Then rinse and wipe completely dry. Wipe splatters immediately with a wet paper towel, especially after cooking greasy foods like chicken or bacon.

Clean your microwave oven weekly or more often, if needed.

### CLEANING AND CARE

Never operate the microwave oven without food in the oven cavity, unless pre-heating with Convection, Pizza, Frozen Foods and Keep Warm mode; this can damage the magnetron tube or ceramic tray. You may wish to leave a cup of water standing inside the oven when it is not in use to prevent damage if the oven is accidentally turned on.

<b>Part</b>	<b>Recommendations</b>
Oven cavity	Keep inside (cavity) of the oven clean. Food particles and spilled liquids can stick to the oven walls, causing the oven to work less efficiently. Wipe up spills immediately. Use a damp, clean cloth and mild soap.
	<b>DO NOT</b>
	use harsh detergents or abrasive cleaners. To help loosen baked-on food particles or liquids, heat 2 cups of water (add the juice of 1 lemon if you desire to keep the oven fresh smelling) in a 4 cup measuring glass at High power for 5 minutes or until boiling. Let stand in oven cavity for 1 or 2 minutes. For baked-on grease splatters, wash with hot, soapy water, rinse and dry.
Wire rack	Wash with soapy water. Rinse thoroughly and dry, or gently rub with cleansing powder or soap-filled pads as directed. The wire rack can also be washed in the dishwasher.
Metal turntable tray	Remove metal turntable tray from the oven when cleaning the oven cavity and tray. Wash the metal turntable tray in warm sudsy water or in the dishwasher.
Ceramic tray	Clean with warm, soapy water or in the dishwasher.
Door seal	Wipe with damp cloth.
Door glass	Wash with soap and water or glass cleaner. Apply Fantastik® or Formula 409® to a clean sponge or paper towel and wipe clean. Avoid using powder cleaning agents, steel wool pads and oven cleaners. If steam accumulates inside or outside the oven door, wipe with a soft cloth. Steam can accumulate when operating the oven in high humidity and can in no way indicate microwave leakage.
Painted surfaces	Clean with hot soapy water or apply Fantastik® or Formula 409® to a clean sponge or paper towel and wipe clean. Avoid using powder cleaning agents, steel wool pads and oven cleaners.
Stainless steel surfaces/ exterior surfaces	Always wipe or rub in the direction of the grain. Clean with a soapy sponge, then rinse and dry, or wipe with Fantastik® or Formula 409® spray on a paper towel. Protect and polish with stainless steel or glass cleaner. Avoid using powder cleaning agents, steel wool pads and oven cleaners. Remove water spots with a cloth dampened with white vinegar.
Plastic & Controls	When cool, clean with soapy water, rinse and dry.
Printed areas (words & numbers)	Do not use abrasive cleaners or petroleum-based solvents.

# Troubleshooting

## MALFUNCTION TABLE

Malfunctions often have simple explanations. Please refer to the malfunction table before calling the after-sales service.

If a meal does not turn out exactly as you wanted, refer to the Expert Cooking Guide section, where you will find plenty of cooking tips and tricks.

**WARNING:** Risk of electric shock!

Incorrect repairs are dangerous. Repairs may only be carried out by one of our trained after-sales engineers.

### Error Code

Error Code	Error Description
F3E1	The temperature sensor in the oven has an open or short circuit fault.
F3E8	The communication of the oven humidity sensor is faulty.
F3E9	The oven humidity sensor module is faulty.
F6E5	The safety protector is disconnected.
F1E1	The communication between the display board and the power supply board is faulty.
F1E4	The communication between the display board and the left touch pad is faulty.
F1E5	The communication between the display board and the right touch pad is faulty.

### NOTE:

Press "CANCEL", then restart the oven. If the problem persists, disconnect all power to your range for at least 30 seconds, then reconnect the power. If this does not solve the problem, call for service.

## ACRYLAMIDE IN FOODSTUFFS

Which foods are affected?

Acrylamide is mainly produced in grain and potato products that are heated to high temperatures, such as potato crisps, chips, toast, bread rolls, bread, fine baked goods (biscuits, gingerbread, cookies).

Tips for keeping acrylamide to a minimum when preparing food	
General	Keep cooking times to a minimum. Cook meals until they are golden brown, but not too dark. Large, thick pieces of food contain less acrylamide.
Baking biscuits Oven chips	Max. 200°C in Top/bottom heating or max. 180°C in 3D hot air or Hot air gentle. Max. 190°C in Top/bottom heating. Max. 170°C in 3D hot air mode. E.g., chips, oven chips, and croquettes. Distribute evenly over the baking tray. Cook at least 400 g at once on a baking tray so that the chips do not dry out.

## **ENERGY AND ENVIRONMENT TIPS**

Here you can find tips on how to save energy when baking and roasting and how to dispose of your appliance properly.

### **Saving energy**

- Only preheat the oven if this is specified in the recipe or in the operating instruction tables.
- Use dark, black lacquered or enamelled baking tins. They absorb the heat particularly well.
- Open the oven door as infrequently as possible while you are cooking, baking or roasting.
- It is best to bake several cakes one after the other. The oven is still warm. This reduces the baking time for the second cake. You can also place two loaf tins next to each other.
- For longer cooking times, you can switch the oven off 10 minutes before the end of the cooking time and use the residual heat to finish cooking.

### **Environmentally-friendly disposal**

Dispose of packaging in an environmentally-friendly manner.

## LIMITED WARRANTY

---

Koolmore Supply, Inc. extends a limited warranty to the original purchaser, guaranteeing that this Koolmore product is free from manufacturing defects in material or workmanship for three years from the date of purchase.

Should you discover any such defect within the warranty period, Koolmore Supply, Inc., reserves the right to repair or replace the product without charge, or to cover the cost of replacement parts and repair labor needed to correct defects present at the time of purchase or resulting from regular usage, when the appliance has been installed, operated, and maintained as per the instructions provided.

At its sole discretion, Koolmore Supply Inc. may decide to replace the product. In such an event, your replacement appliance will carry the warranty for the remaining term of the original unit's warranty period.

This warranty is valid exclusively to the original purchaser of the product and only applicable within the United States. The warranty commences from the date of original consumer purchase. Proof of the original purchase date will be required to obtain service under this warranty.

Under this limited warranty, your sole and exclusive remedy will be product repair, as outlined above. All services must be provided by a Koolmore-designated service company.

To claim warranty or request repair service:

Email [support@koolmore.com](mailto:support@koolmore.com). Please include your name, address, phone number, warranty repair request, and a copy of your proof of purchase receipt. Alternatively, visit [koolmore.com](http://koolmore.com) and use the contact us page. A Koolmore customer service representative will promptly arrange service for your appliance.

We thank you for choosing Koolmore.

## WARRANTY EXCLUSIONS

---

This limited warranty will not cover:

1. Failure of the product to perform during power failures or interruptions, or due to inadequate electrical service.
2. Damage incurred during transportation or handling.
3. Damage caused by accidents, vermin, lightning, winds, fire, floods, or acts of God.
4. Damage resulting from accidents, alterations, misuse, abuse, improper installation, repair, or maintenance. This includes using any external device that alters or converts the voltage or frequency of electricity.
5. Unauthorized product modifications, repairs by unauthorized centers, or use of non-approved replacement parts.
6. Abnormal cleaning and maintenance not aligned with the user's manual.
7. Use of incompatible accessories or components.
8. Any costs associated with repairs or replacements under these excluded circumstances shall be the responsibility of the consumer.

**KOOLMORE**

---

R E S E R V E