

# BED

## Assembly Manual

### KJW.B022

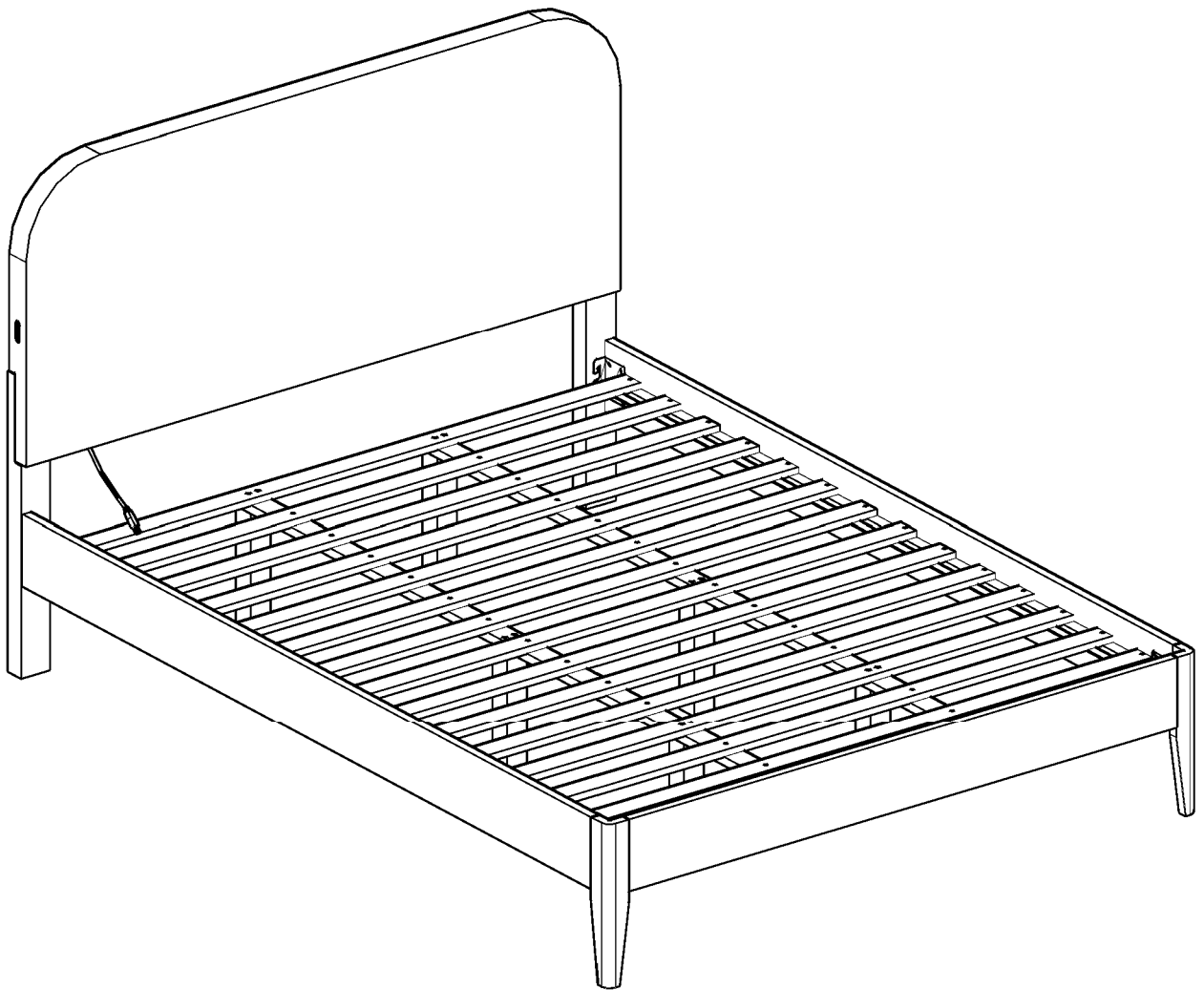

 **CAUTION**

THIS ASSEMBLY MANUAL CONTAINS IMPORTANT SAFETY INFORMATION.

PLEASE READ AND KEEP FOR FUTURE REFERENCE.

**ASSEMBLY INSTRUCTIONS**

1. Read these instructions carefully and keep them for future reference.
2. Refer to the parts inventory for guidance, and ensure you have all pieces before starting.
3. When assembling, place all parts on a soft, clean, and flat surface (e.g., a carpet) to prevent scratches.

**!** Structural integrity is only guaranteed if all bolts are installed and properly tightened.



TIME

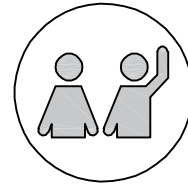



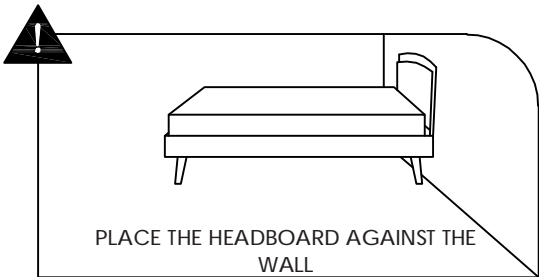

2 OF PEOPLE

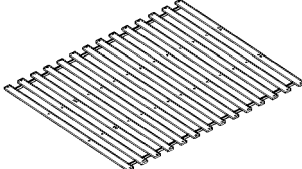
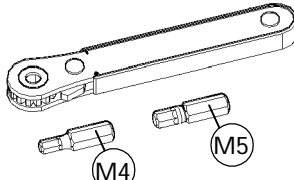
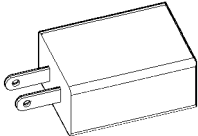
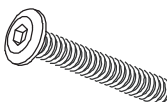
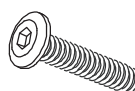
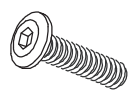

<p>1. HEADBOARD ×1</p>	<p>2. HEADBOARD LEG (LEFT) ×1</p>	<p>3. HEADBOARD LEG (RIGHT) ×1</p>
<p>4. FOOTBOARD ×1</p>	<p>5. SIDE RAIL (LEFT) ×1</p>	<p>6. SIDE RAIL (RIGHT) ×1</p>
<p>7. FOOTBOARD LEG ×2</p>	<p>8. CENTER LEG ×6</p>	<p>9. CENTER RAIL ×2</p>

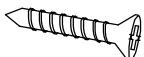
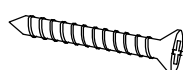
Please read through the instructions below to familiarize yourself with the parts and steps before assembly.

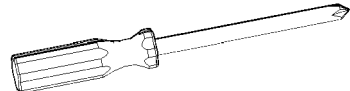
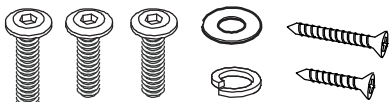
<p>10.SLATS ×14 (1SET)</p> 	<p>A.RATCHET TOOL ×1</p> 	<p>B.POWER ADAPTER ×1</p> 
<p>C.JCBC BOLT M6 X 50MM ×8</p> 	<p>D.JCBC BOLT M6 X 45MM ×6</p> 	<p>E.JCBC BOLT M6 X 40MM ×4</p> 
<p>F.M6 SPRING WASHER ×6</p> 	<p>G.M6 FLAT WASHER ×6</p> 	<p>H.WOOD SCREW M3.5 X 16MM ×2</p> 
<p>I.WOOD SCREW M4 X 25MM ×52</p> 	<p>J.FOOT PADS ×10</p> 	<p>Not Included</p>  <p>Phillips Head Screwdriver</p>
<p>Extra Hardware</p> 		

Please read through the instructions below to familiarize yourself with the parts and steps before assembly.

Before you begin:

1. Check if you have received all parts using the diagram on this page. Do not start the assembly process until all parts are present.

2. Do not discard any of the packaging until you are certain that you have all the necessary parts for the assembly.

# ASSEMBLY INSTRUCTIONS

**1** Please lay all parts on a soft and smooth surface to assemble.

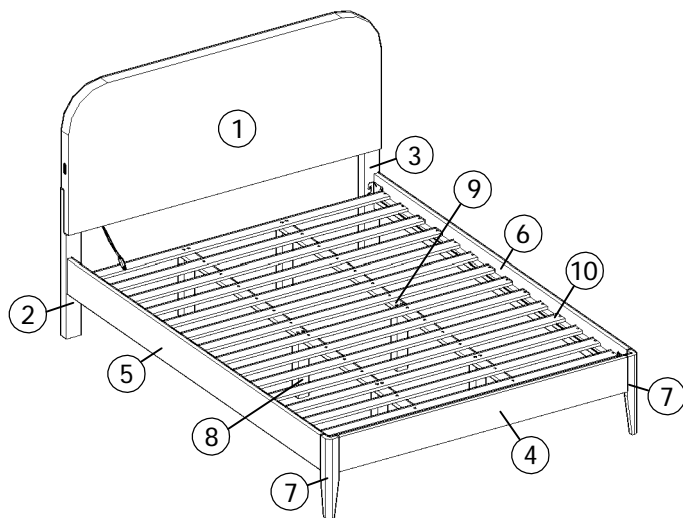
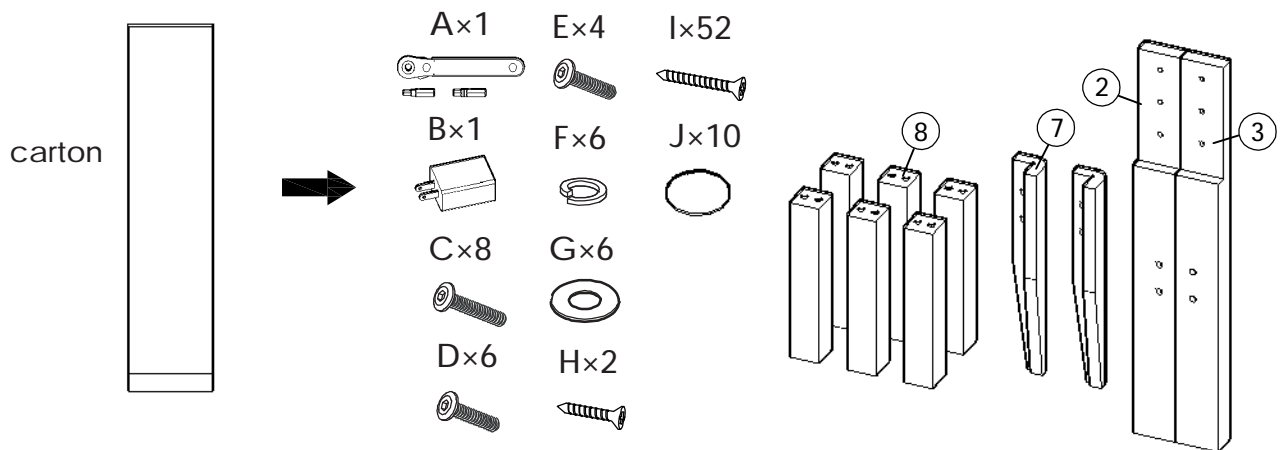
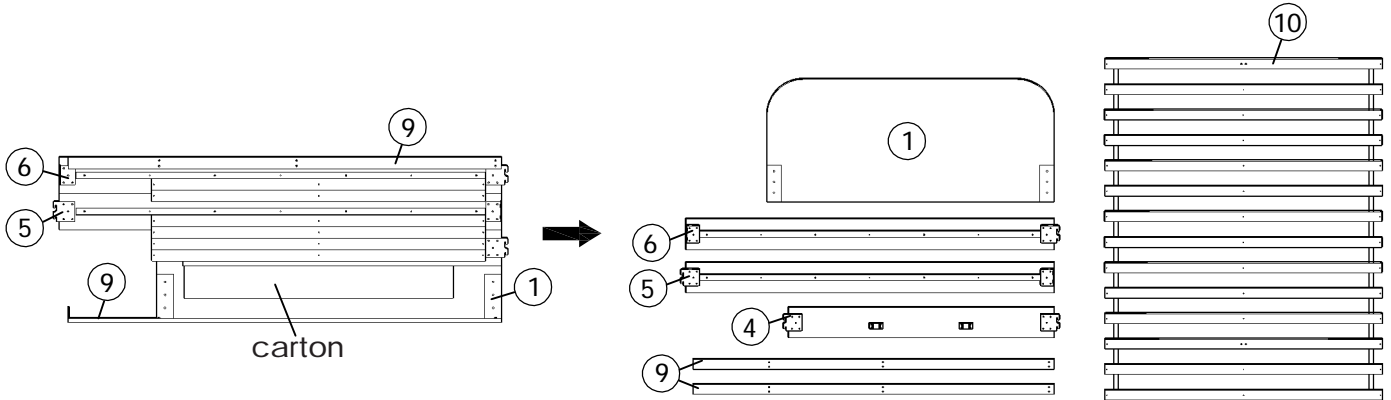

- 2** Attach the Headboard (1) to the Headboard Leg (Left)(2) and Headboard Leg (Right)(3), using JCBC Bolt M6 X 45MM (D), M6 Spring Washer (F), M6 Flat Washer (G) and M4 Ratchet Tool (A). Fully tighten.

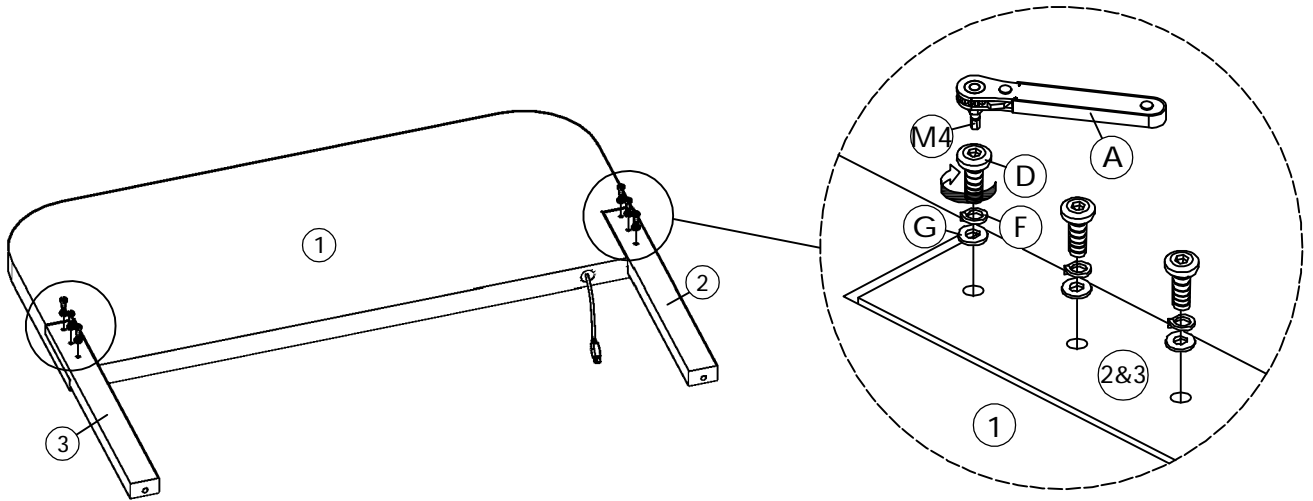

- 3** Attach the Footboard Leg (7) to the Footboard (4), using the M5 Ratchet Tool (A). Note: Loosen the pre-attached bolt slightly before attaching the Side Rails, and Do not fully tighten yet.

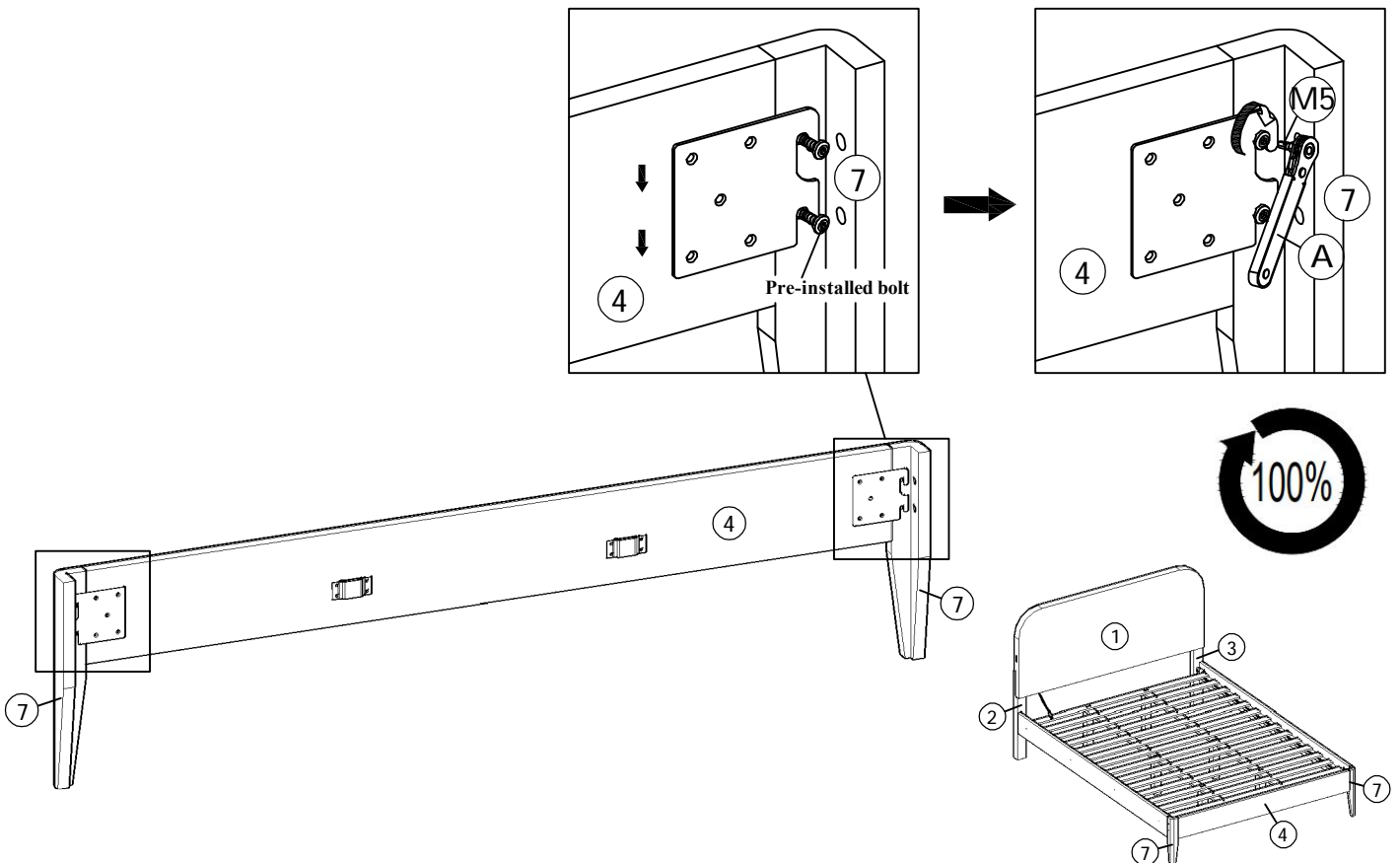

- 4** Attach the Side Rail (5),(6) to the Footboard Leg(7), using the M5 Ratchet Tool (A). Note: Loosen the pre-attached bolt slightly before attaching the Side Rails, and Do not fully tighten yet.

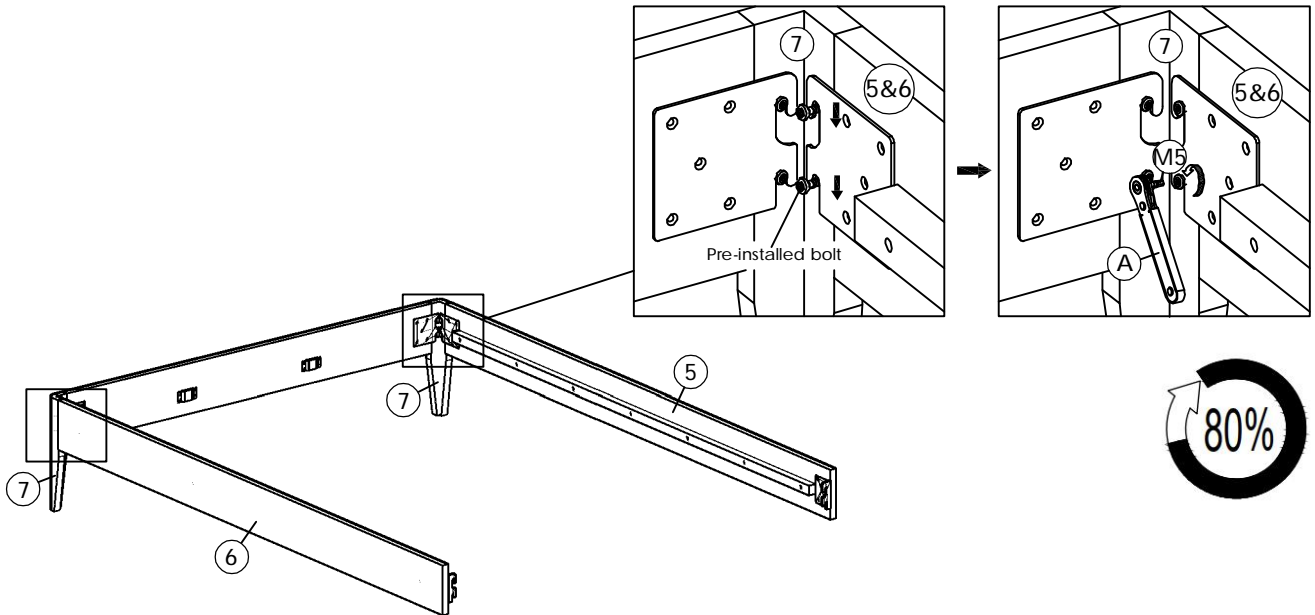

- 5** Attach the Side Rail (5),(6) to the Headboard Leg (2),(3) using the M5 Ratchet Tool (A). Note: Loosen the pre-attached bolt slightly before attaching the side rails, and Do not fully tighten yet.

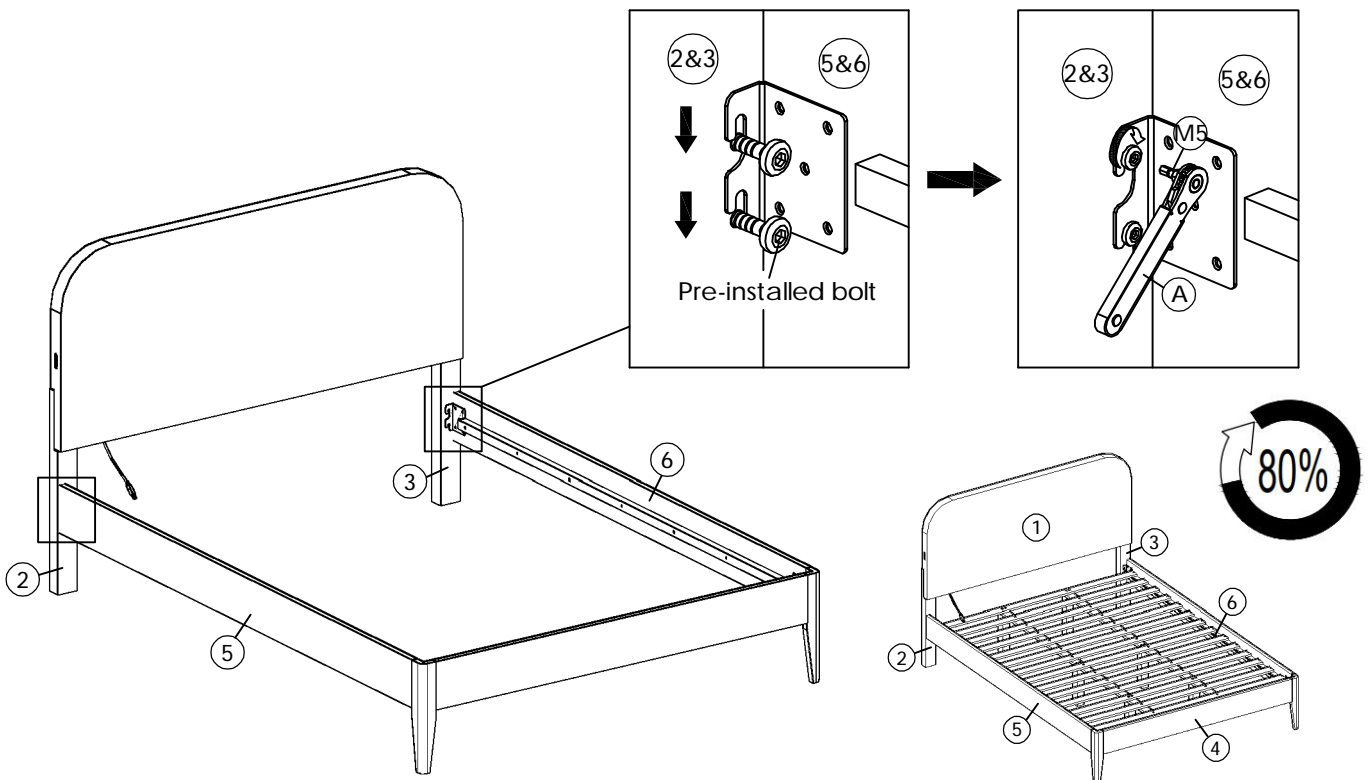

- 6** Attach 2pcs Center Leg (8) to Center Rail (9), using JCBC Bolt M6 X 40MM (E) and M4 Ratchet Tool (A). Fully tighten.

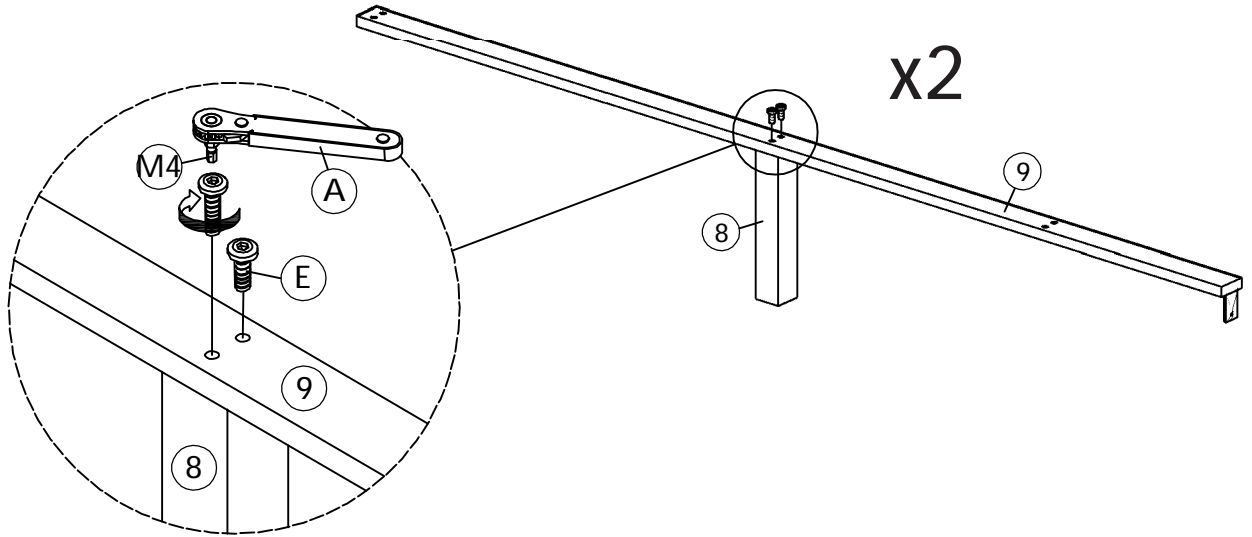

- 7** Attach the 4 pcs of Center Leg (8) and Slats (10) to the Center Rail (9), using JCBC Bolt M6 x 50mm (C) and the M4 Ratchet Tool (A). Fully tighten.  
 Note: Optionally, paste the Foot Pads (J) underneath the Center Leg (8).

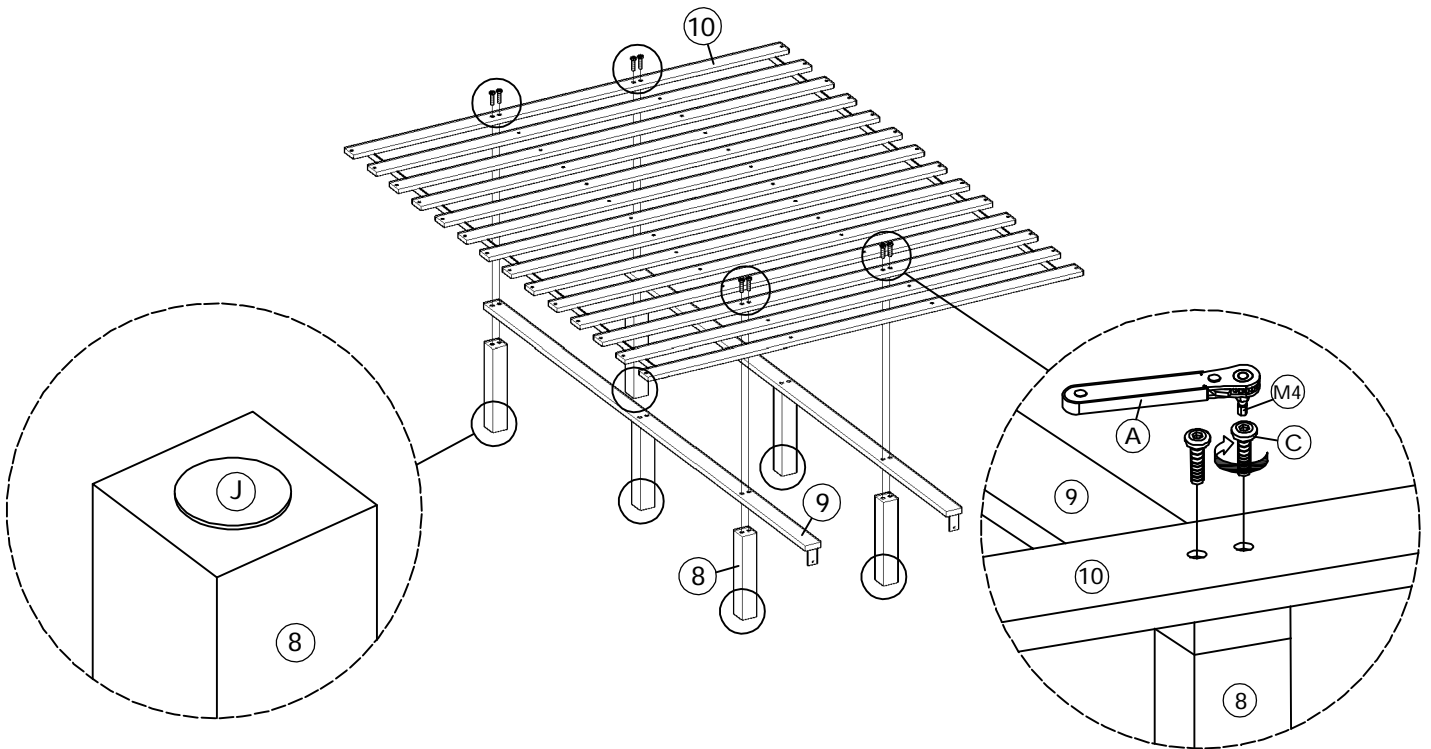

- 8** Attach the assembled Center Rail (9) to the Footboard (4), using Wood Screw M3.5 x 16mm (H) and a Phillips Head Screwdriver (Not Included). Fully tighten.

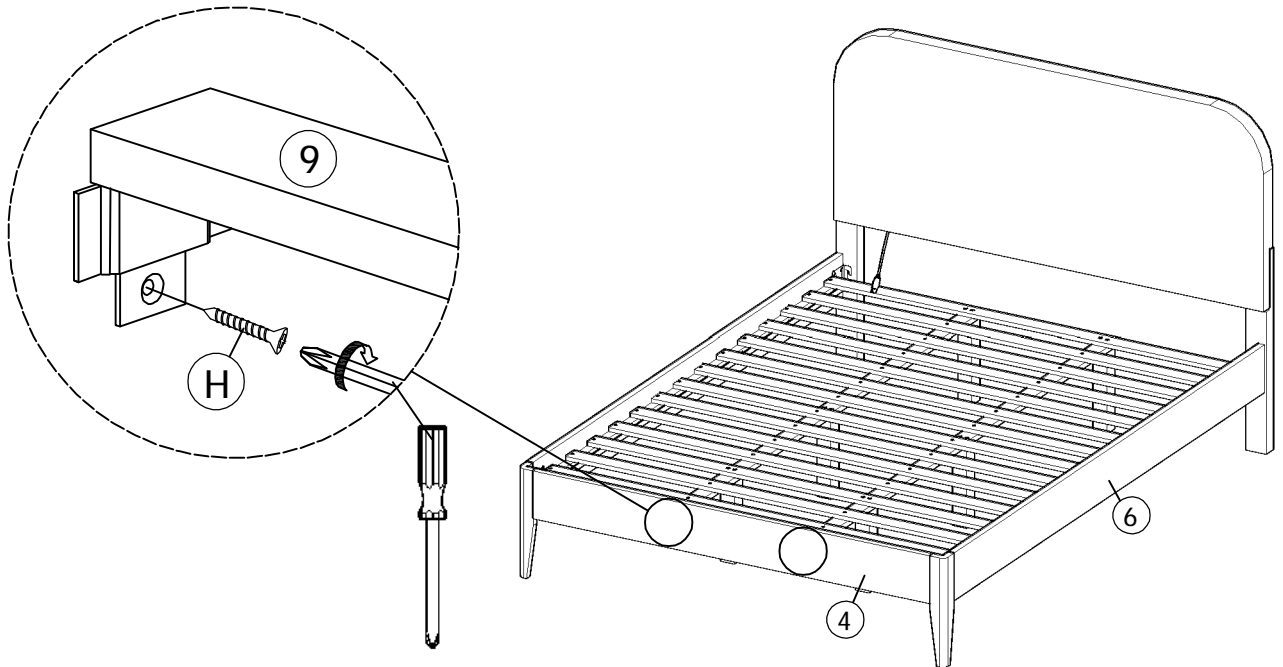

- 9** Attach Slats x14 (1 Set) (10) to Side Rail (5) and (6), using Wood Screw M4 X 25MM (I) and Phillips Head Screwdriver (Not Included). Fully tighten. Note: Please fully tighten the four side screws that shown in below circled, then fully tighten the others Screws.

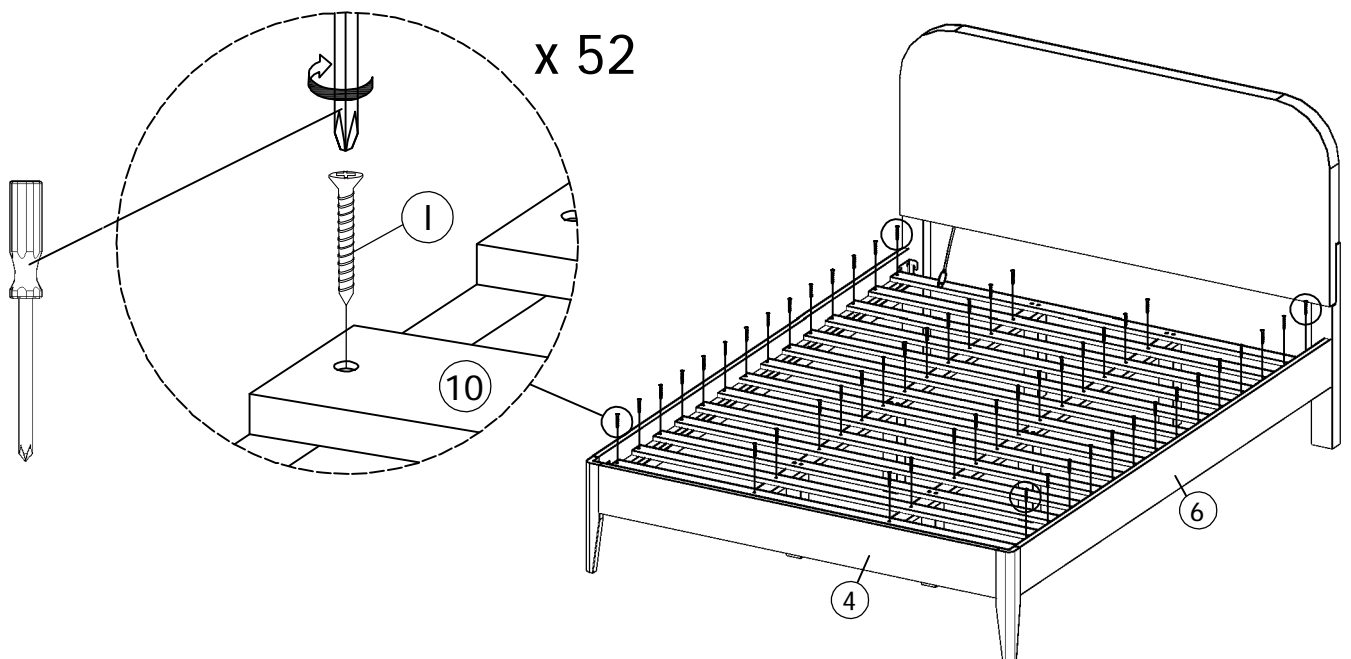

- 10** Assembly Completed using M5 Ratchet Tool (A).  
Note: Fully tighten the Headboard Leg and Footboard Leg pre-attached bolt.

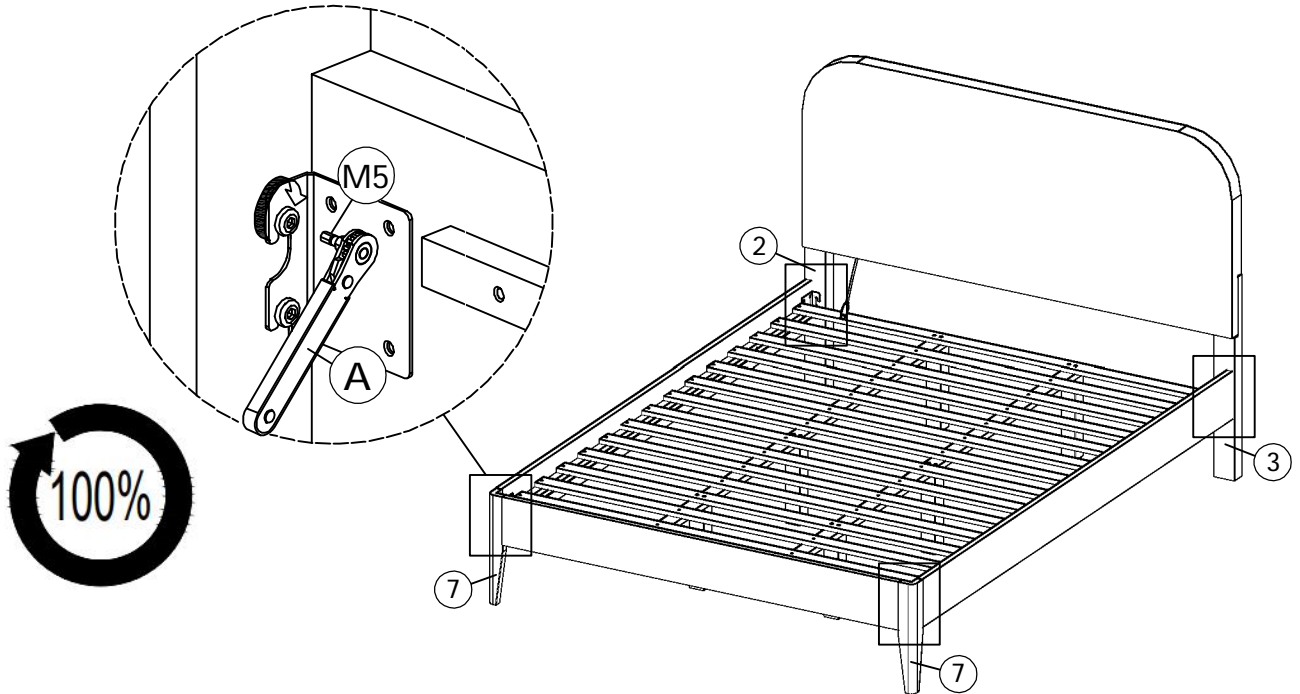

- 11** Paste the Foot Pads (J) underneath the below circled (optional).

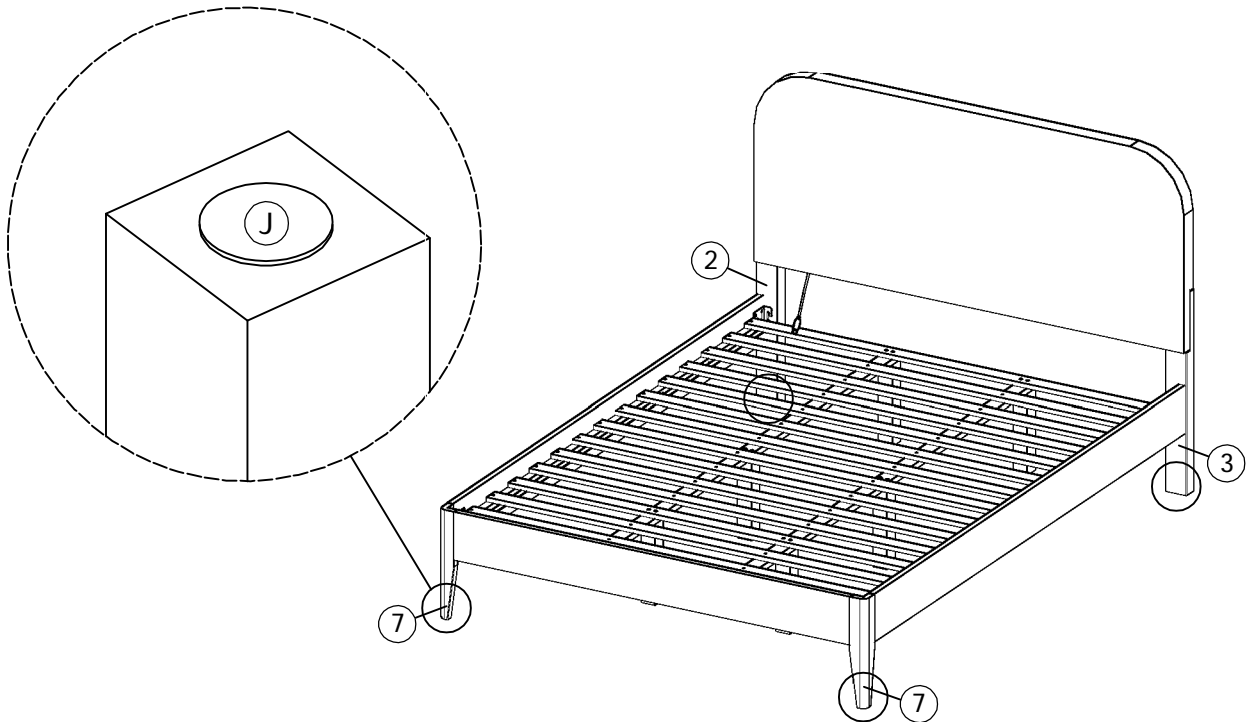

**12** Attach USB into Power Adapter (B) .

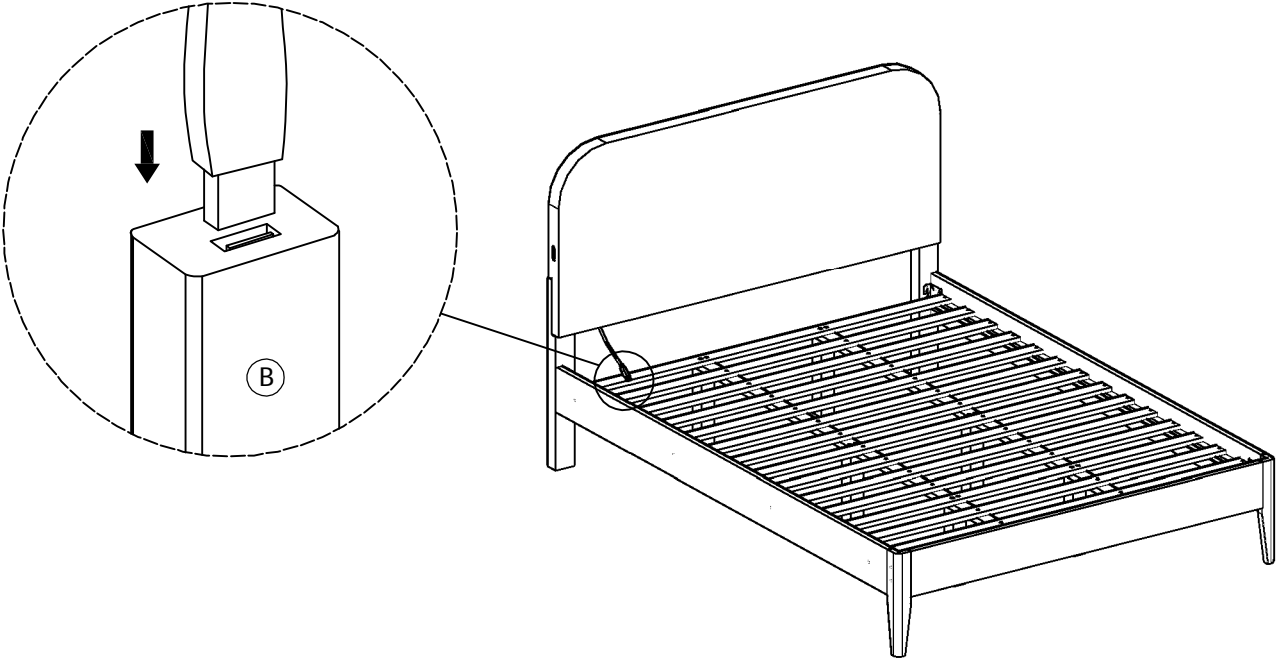

**13** Assembly Completed. Enjoy.

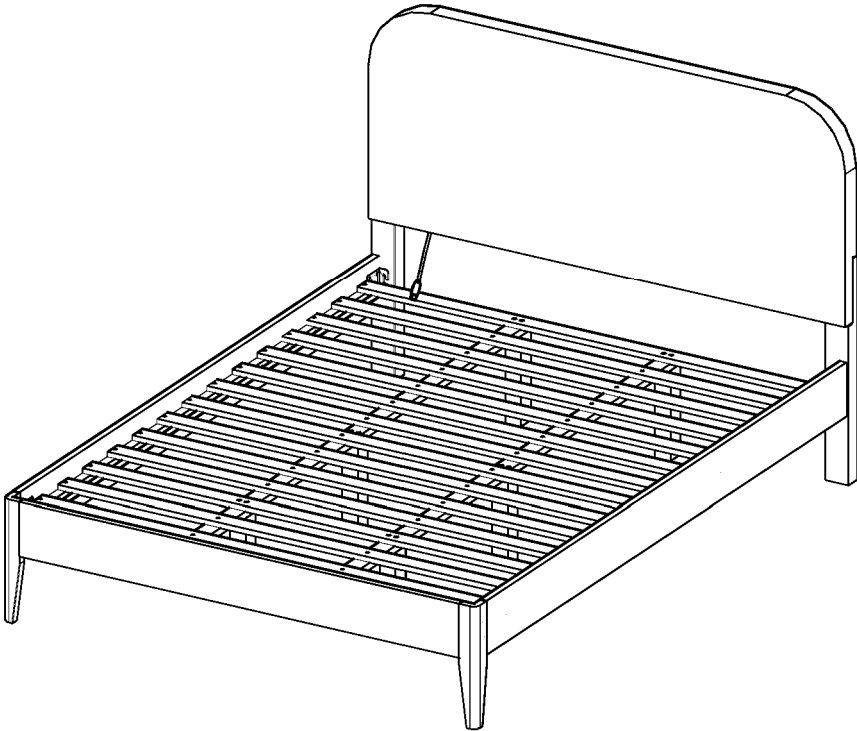

# Design Exquisite Furniture For Your Home

---

## PRODUCT WARRANTY

- 1-year limited on cover against splitting, peeling, and/or tearing.
- 1-year limited on internal and external frame structure.

## Contact us:

We make all efforts to guarantee that the products you receive are in excellent condition. If there are any parts missing or damaged, the Customer Service Team will be happy to provide free replacements for you. We have professional warehouses where the current inventory of parts is enough so that they will arrive in your hands as fast as possible.

Assistance with assembly or product details is available; don't hesitate to get in touch with us to get priority service.

Our E-mail address: [CS.furniture@outlook.com](mailto:CS.furniture@outlook.com).



[CS.furniture@outlook.com](mailto:CS.furniture@outlook.com)