

# Assembly Instructions

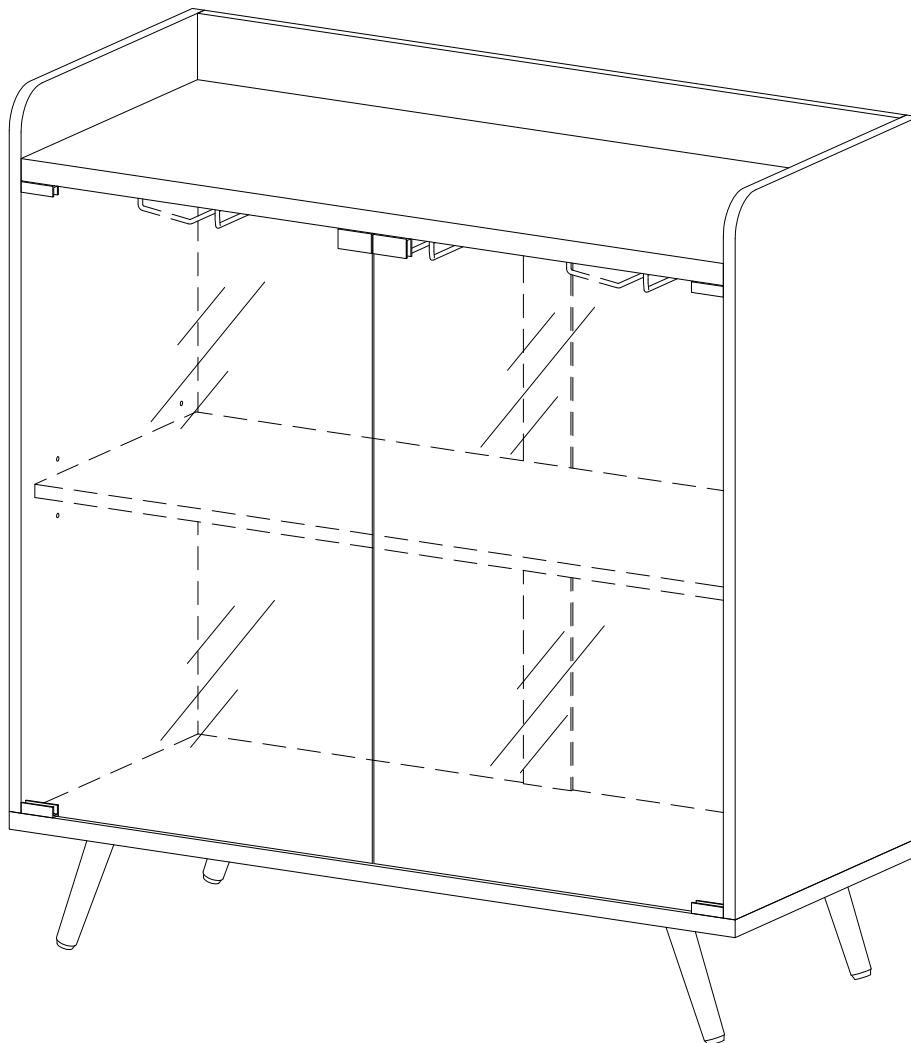

# General Assembly Guidelines

- I. Ensure that all parts and hardware are available before beginning assembly.
- II. Follow each step carefully to ensure the proper assembly of this product.
- III. Two people are recommended for ease in the assembly of this product.
- IV. The three main types of hardware used to assemble this product are : wood dowels , screws and bolts.
- V. The provided glue is to secure wood dowels in place . When first inserting dowels , locate the appropriate hole for the dowel , place a small amount of glue in the hole and insert the dowel . Wipe away excess glue immediately.

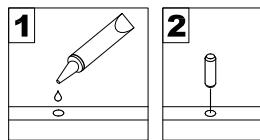

In future assembly steps when dowels are necessary to attach assembly parts together , place a small amount of glue on the end of the dowel before attaching parts together . Wipe away excess glue immediately.

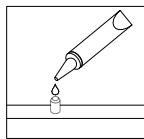

- VI. A Phillips head screwdriver is required for the assembly of this product .

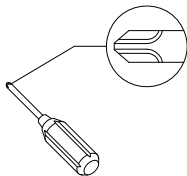



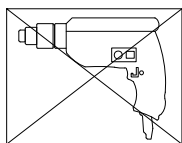



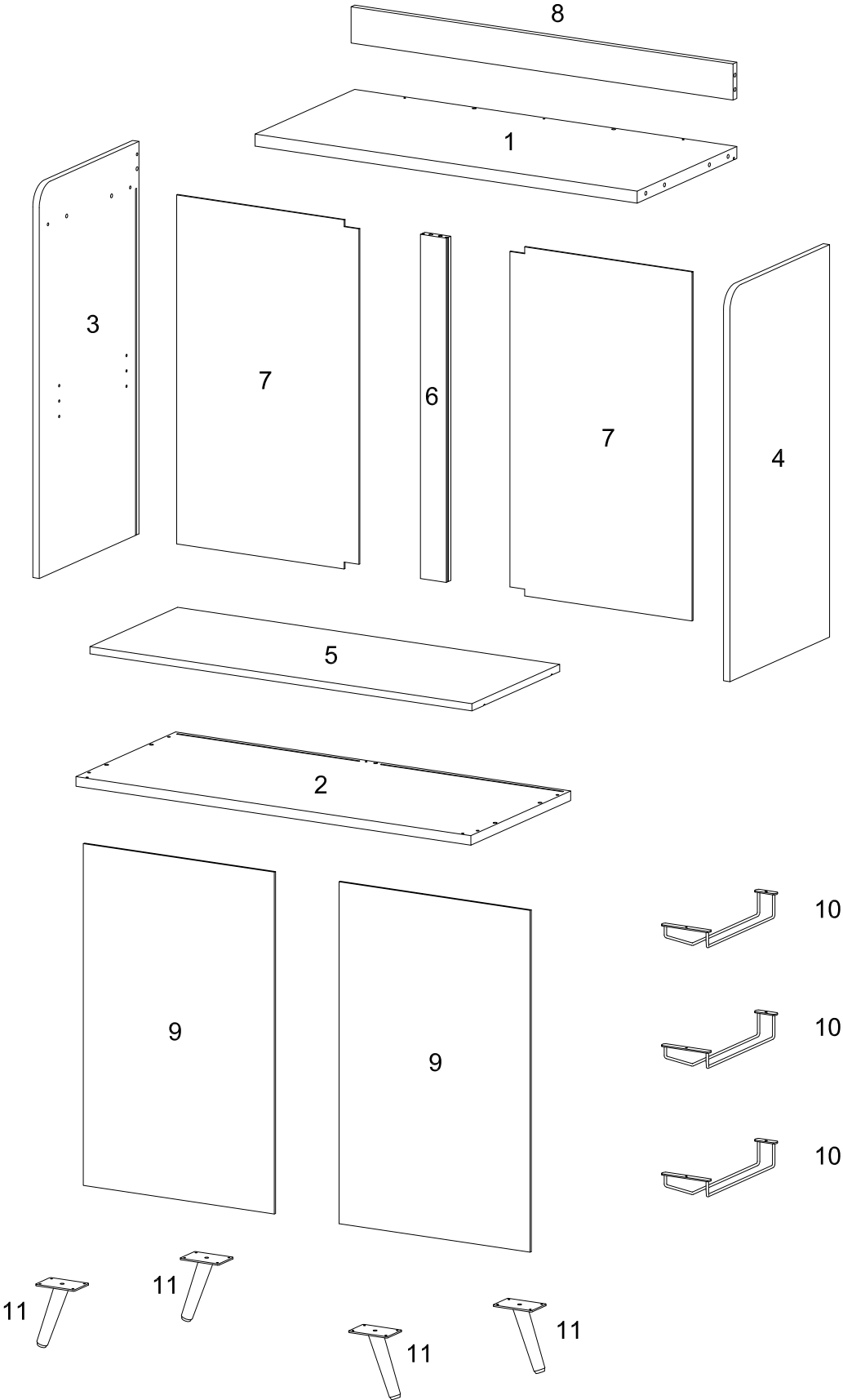





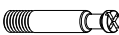

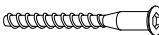

- VII. Power tools should not be used to assemble this product .

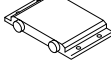

# Parts List

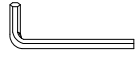

# Hardware List

A		Ø8x30mm	Wooden dowel	14 pcs
B		Ø6x12mm	Bolt	16 pcs
C		Ø15x11mm	Cam lock	7 pcs
D		Ø6x35mm	Cam bolt	7 pcs
E		Ø30mm	Sticker	7 pcs
F		Ø6x50mm	Bolt	4 pcs
G			Plastic wedge	8 pcs
H		Ø3x17mm	Screw	8 pcs
J		Ø5x16	Shelf support pin	4 pcs
K			Plastic pivot	4 pcs
L			Glass Hinge	2 pcs
M			Glass Hinge	2 pcs
N			Door stopper	1 pcs
P		Ø3x15mm	Screw	6 pcs
Q		Ø4x45mm	Screw	4 pcs
R		M 4	Hex Key	1 pcs
S			Glue tube	1 pcs
T		Ø3x15mm	Screw	4 pcs
U			Metal plate	2 pcs

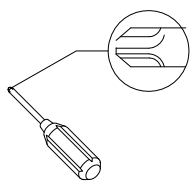

Philips head screwdriver required for assembly  
(not included)

*The hardware quantities listed above are required for proper assembly.  
Some extra hardware may also have been included.*

# Step 1

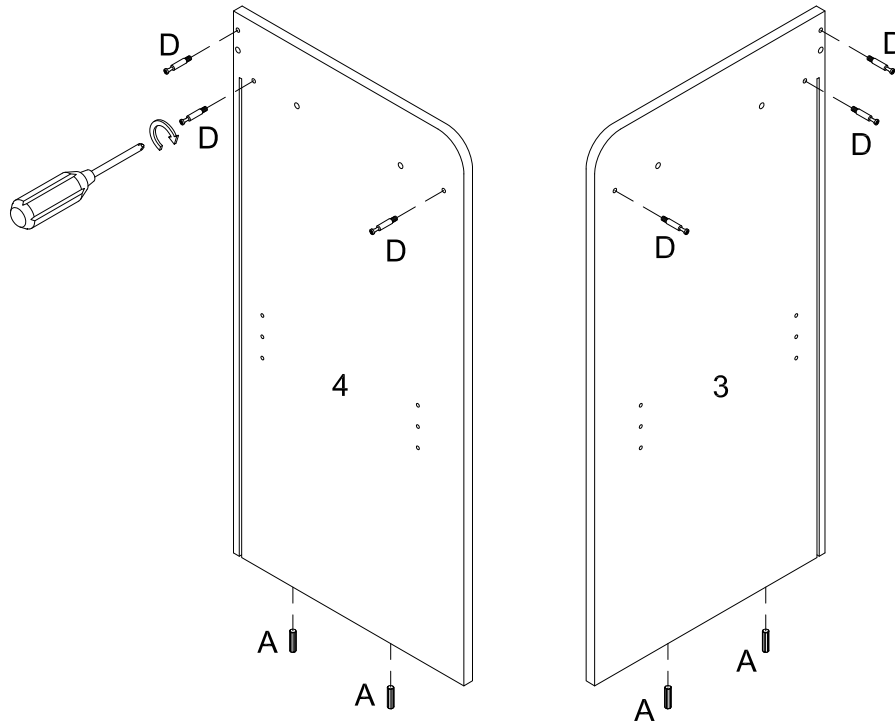

Insert wooden dowel (A) and secure cam bolt (D) with screwdriver into part (3,4).

# Step 2

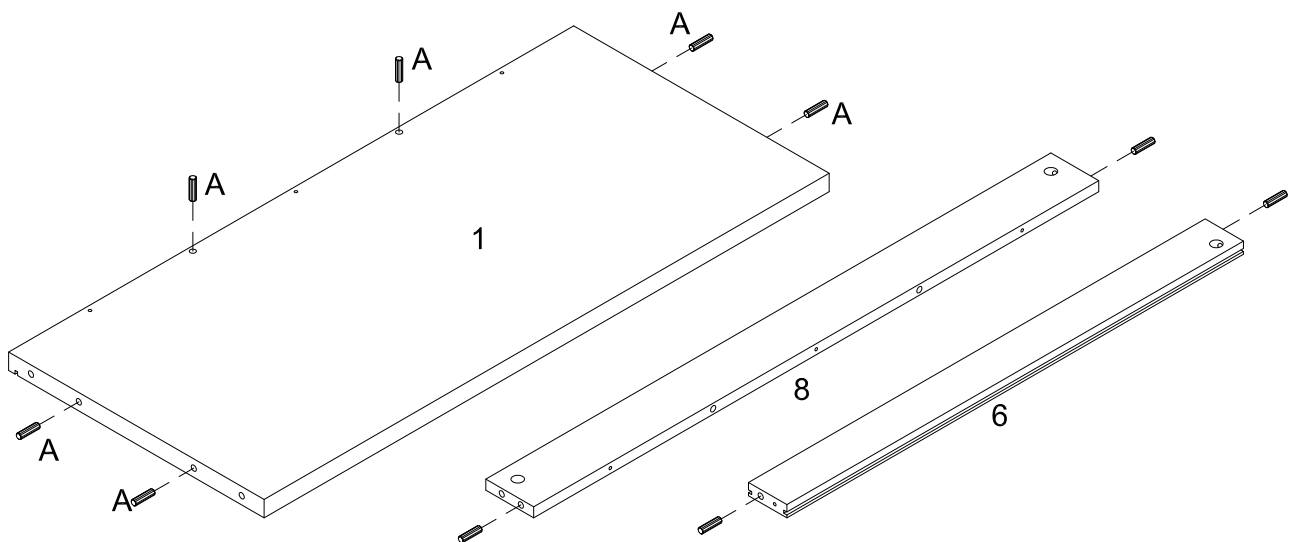

Insert wooden dowel (A) into part (1,6,8).

## Step 3

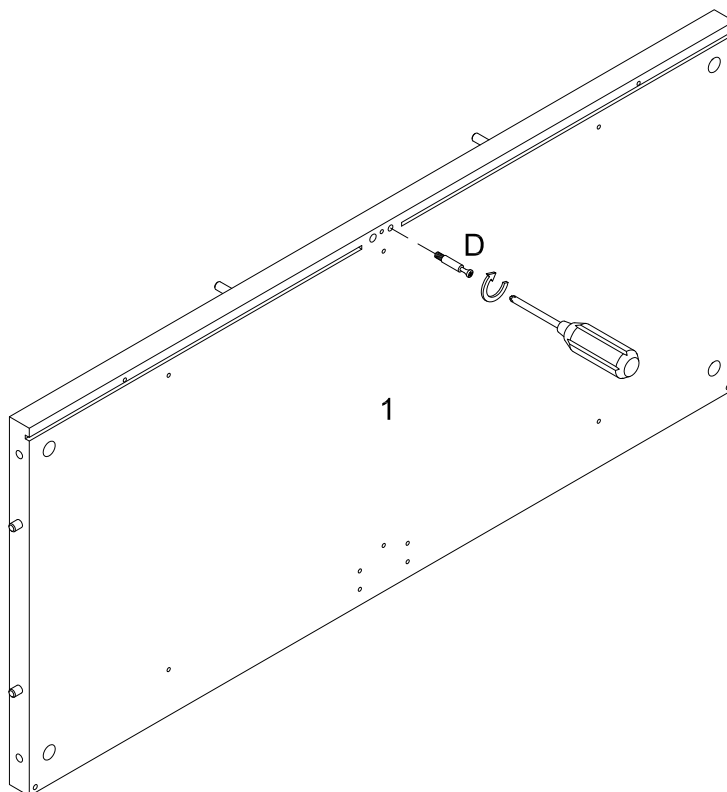

Secure cam bolt (D) with screwdriver to part (1).

## Step 4

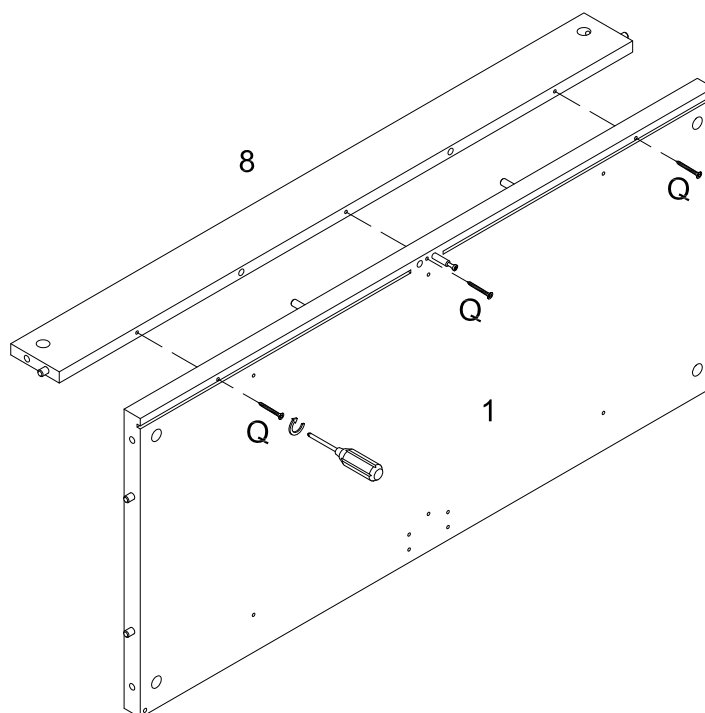

Attach part (1) to part (8) using screw (Q) with screwdriver.

## Step 5

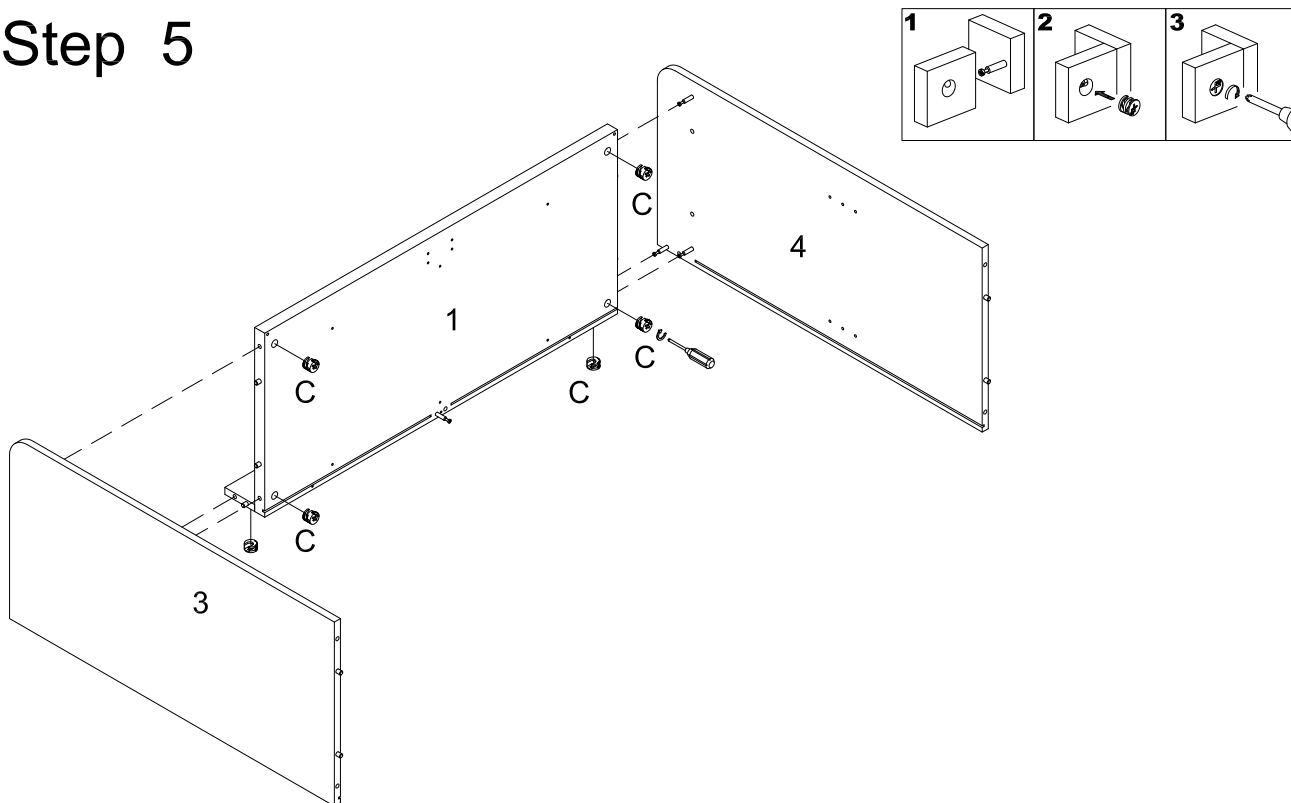

Attach part (3,4) to part (1), then insert and secure cam lock (C) to part (1) to lock it.

## Step 6

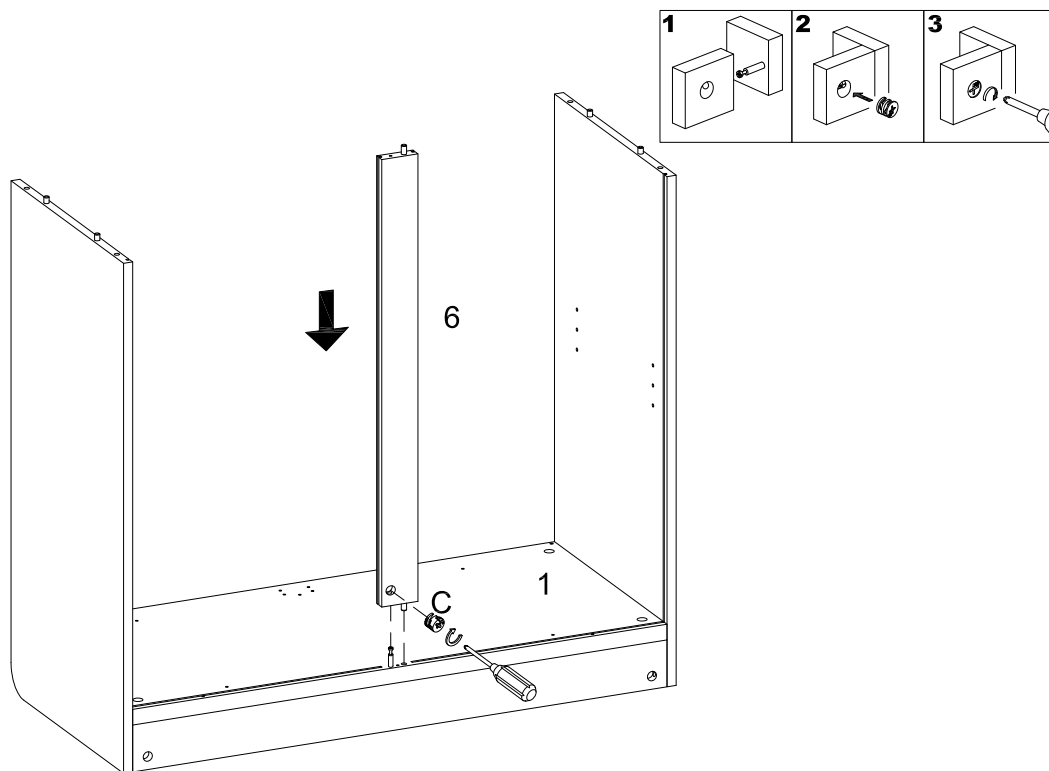

Attach part (6) to part (1), then insert and secure cam lock (C) to part (1) to lock it.

## Step 7

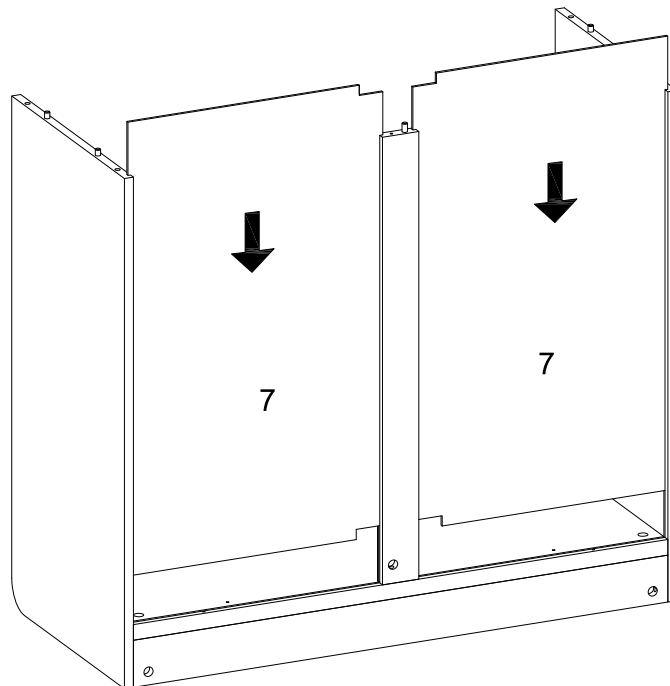

Slide back panel (7) into grooves as per diagram.

## Step 8

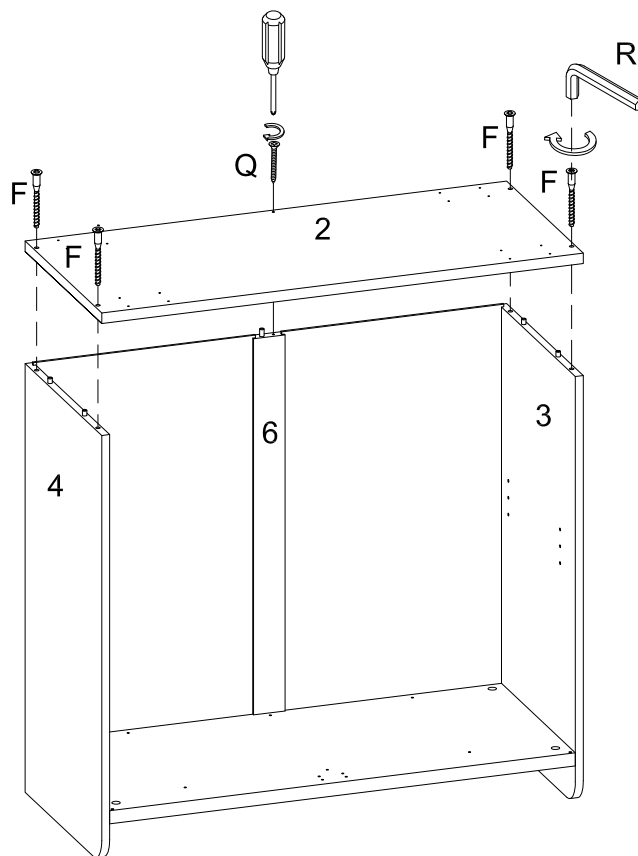

Attach part (2) to part (3,4,6) using bolt (F) with hex key (R), and screw (Q) with screwdriver.

## Step 9

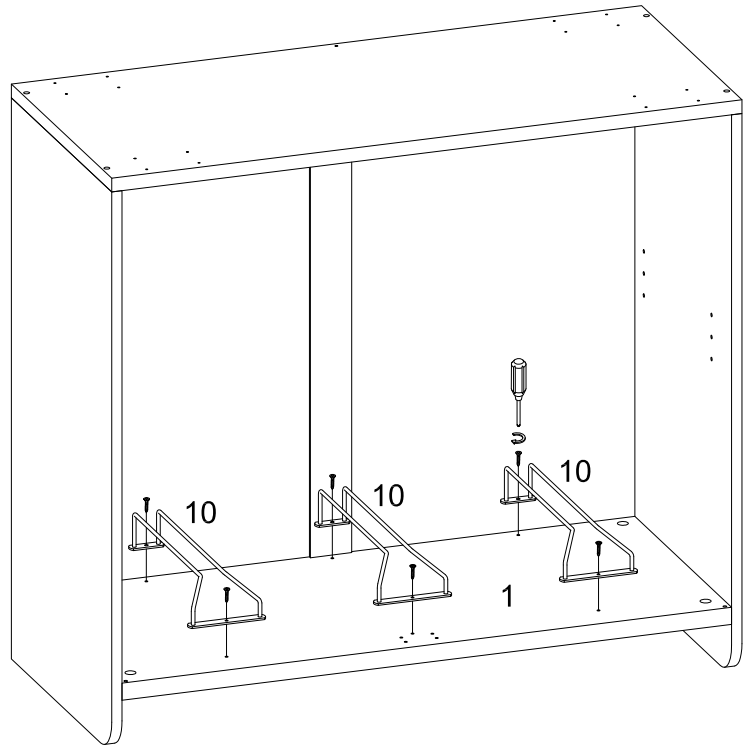
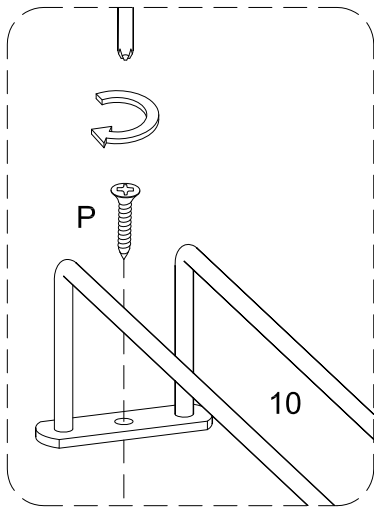

Attach part (10) to part (1) using screw (P) with screwdriver.

## Step 10

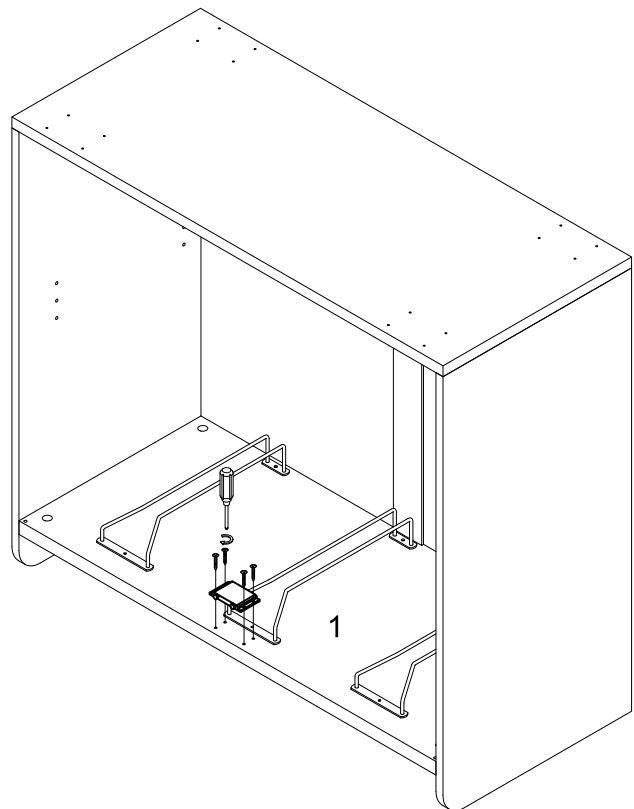
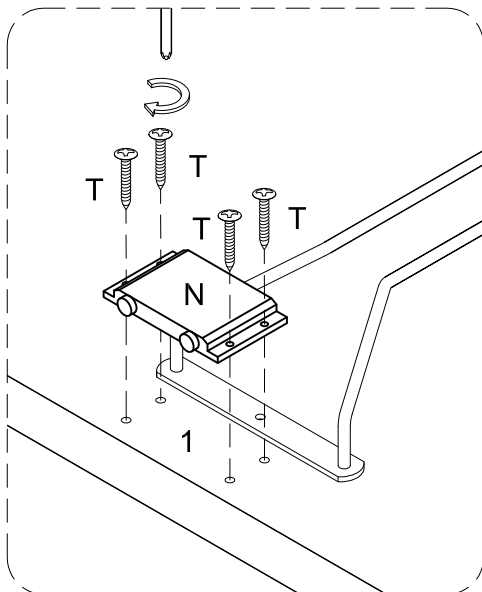

Attach door stopper (N) to part (1) using screw (T) with screwdriver.

## Step 11

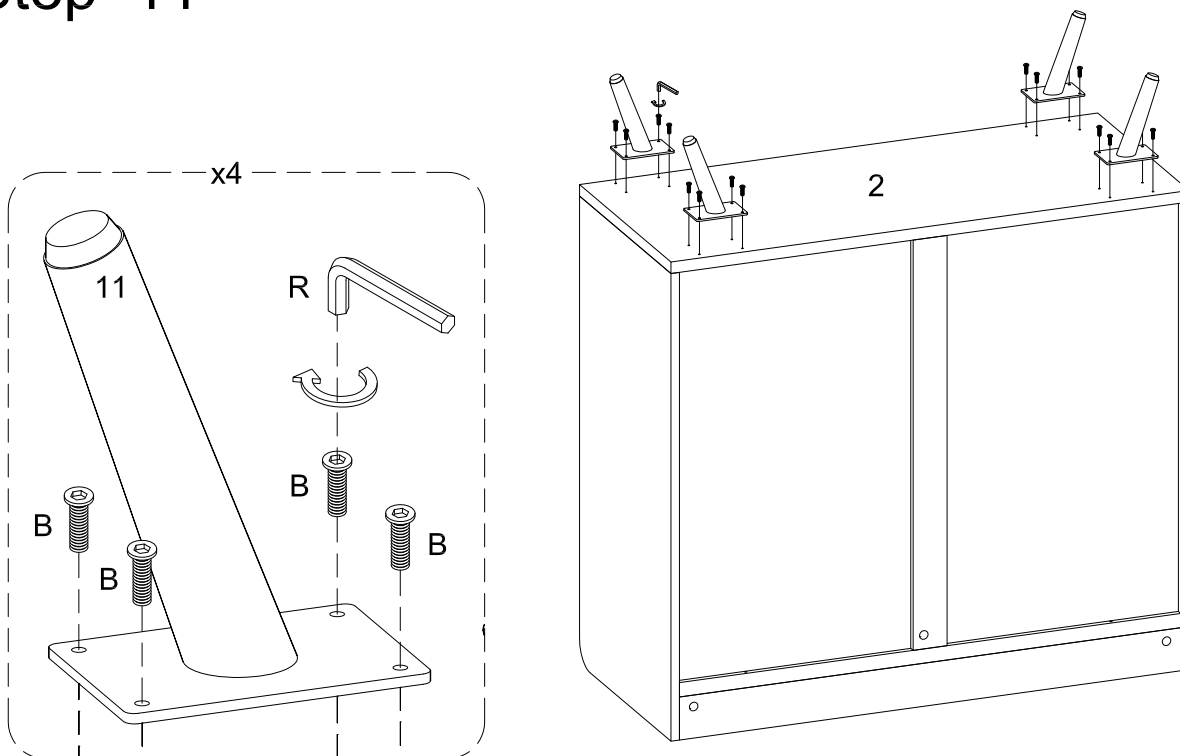

Attach part (11) to part (2) using bolt (B) with hex key (R).

## Step 12

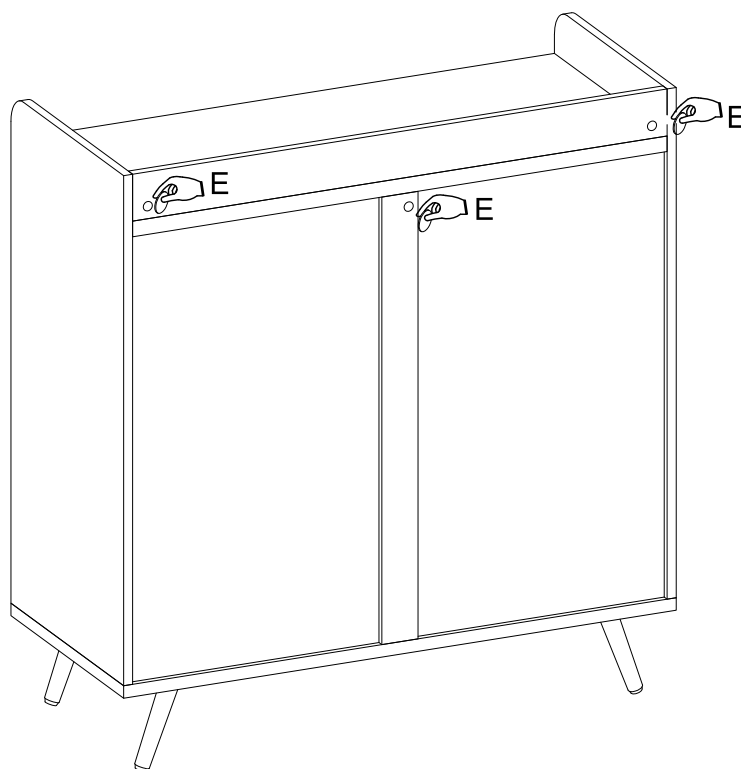

Place sticker (E) over holes as per diagram.

## Step 13

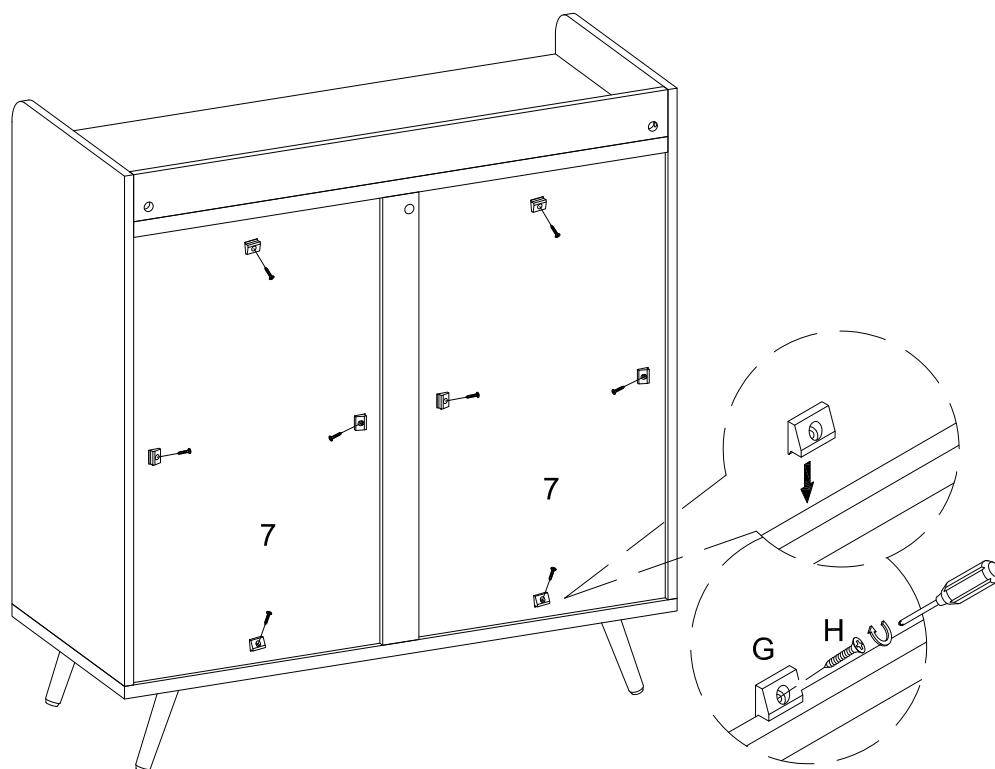

Attach plastic wedge (G) to part (7) using screw (H) with screwdriver.

## Step 14

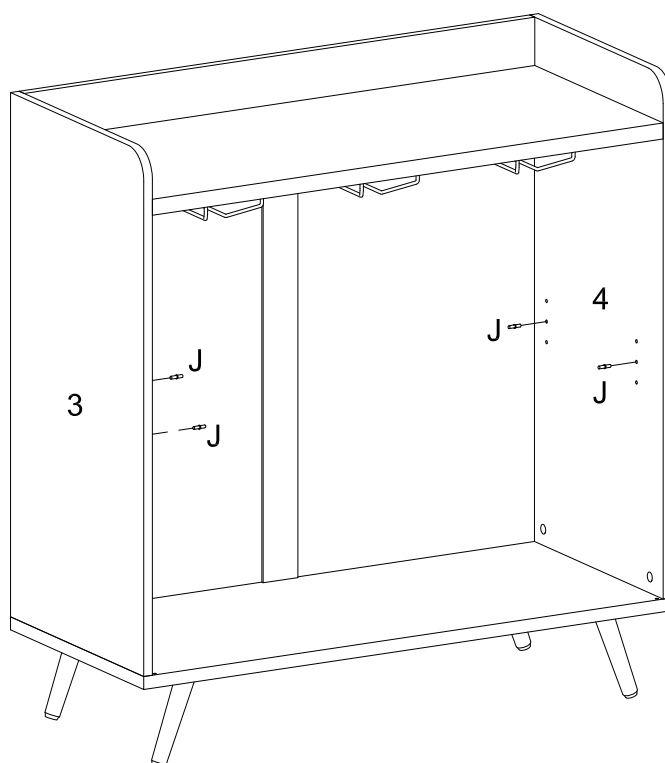

Insert shelf support pin (J) into side panel (3,4).

## Step 15

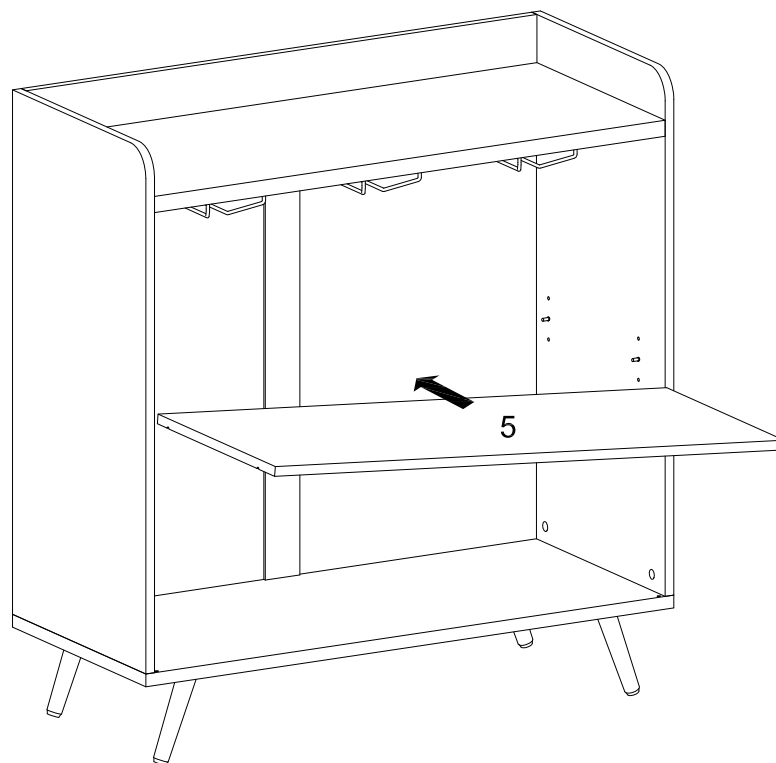

Place shelf (5) on top of support pin (J).

## Step 16

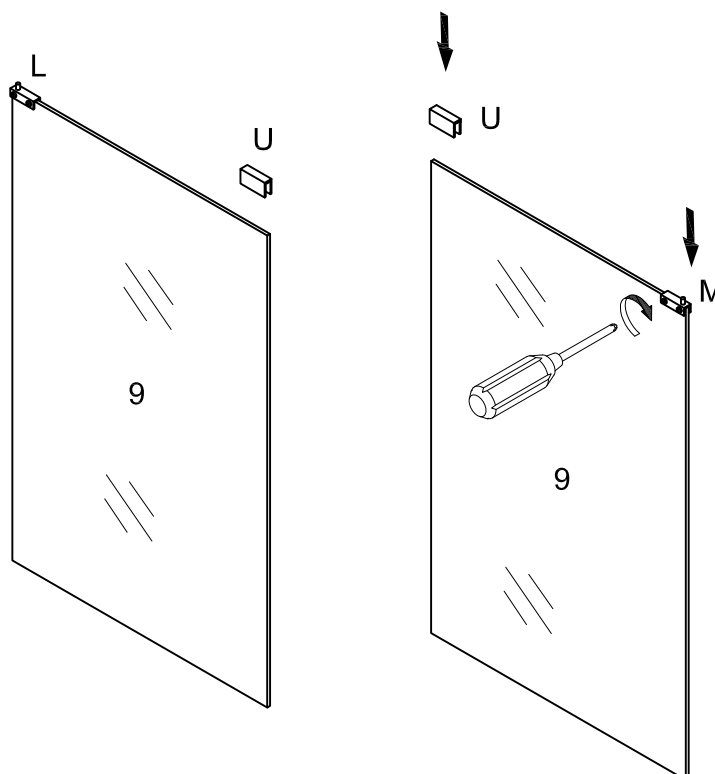

Attach glass holder (L,M,U) to part (9) with screwdriver.

## Step 17

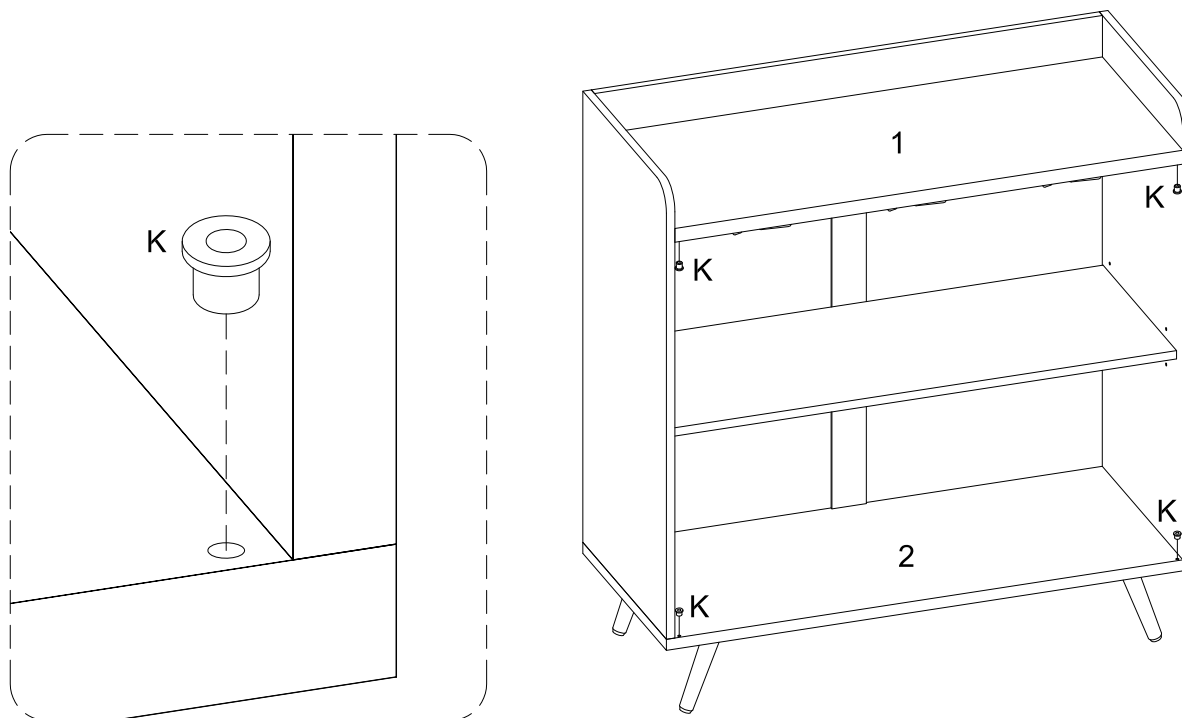

Place plastic pivot (K) over holes as per diagram.

## Step 18

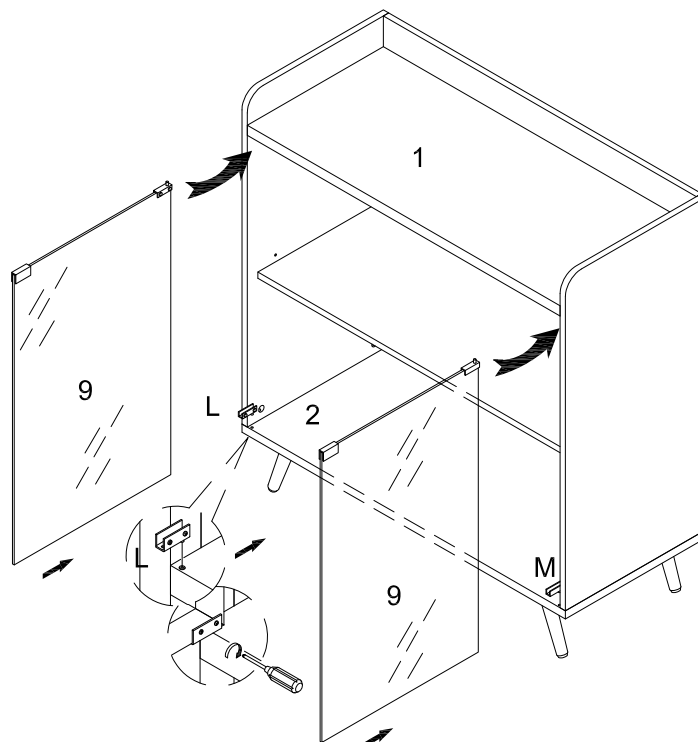

Place hinge (L) into plastic pivot (K) on part (2). Insert top hinge (L) into plastic pivot (K) on part (1), then slide the glass door (9) into the bottom hinge (L). Secure door by tightening door hinge (L,M) screws with equal pressure. Glass doors can be adjusted by carefully loosening the hinge screws and adjusting the glass placement to optimize door alignment. Re-tighten the hinge screws.

# Step 19



Final Assembly