

**Bar Stool**  
**Assembly Instructions**

## ASSEMBLY INSTRUCTIONS | Bar Stool with Wooden Backrest

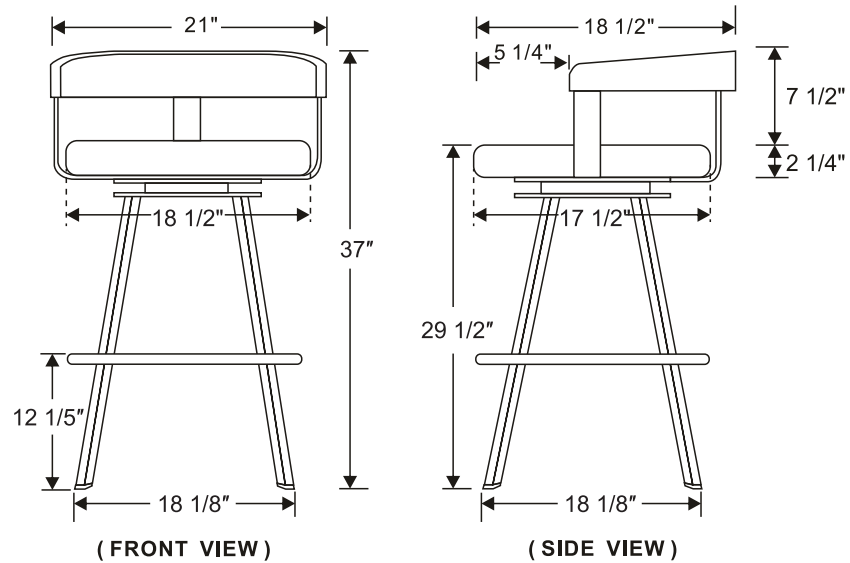

1

Thank you for purchasing this product. Please carefully check all packaging materials for small parts that may have become loose during shipping. Identify and count all parts, and compare them with the Parts List and Hardware List below.

Before assembly, place all components on a clean, soft surface such as carpet or a padded mat to prevent damage.

## GENERAL INFORMATION, TIPS & TRICKS

1. Read all instructions carefully before beginning assembly.
2. Assemble the product on a non-abrasive surface to avoid scratches.
3. Do not fully tighten bolts until all parts are assembled.
4. Ensure all bolts and screws are securely tightened before use.
5. Clean with a soft damp cloth. Avoid excessive moisture.

2

**•YOU WILL NEED**





A Phillips screwdriver is required for assembly.





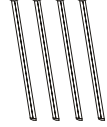
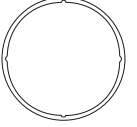

Do not use power tools to avoid damage.

**•PARTS LIST**

① Seat Cushion	② Backrest	③ Stool Legs	④ Footrest Ring
			
QTY: 1PC	QTY: 1PC	QTY: 4 PCS	QTY: 1 PC

**•HARDWARE LIST**

Ⓐ Short Bolt	Ⓑ Long Bolt	Ⓒ Screw	Ⓓ Assembly Instruction
			
QTY: 12 PCS	QTY: 4 PCS	QTY: 9PCS	QTY: 1 PC

## ASSEMBLY INSTRUCTIONS

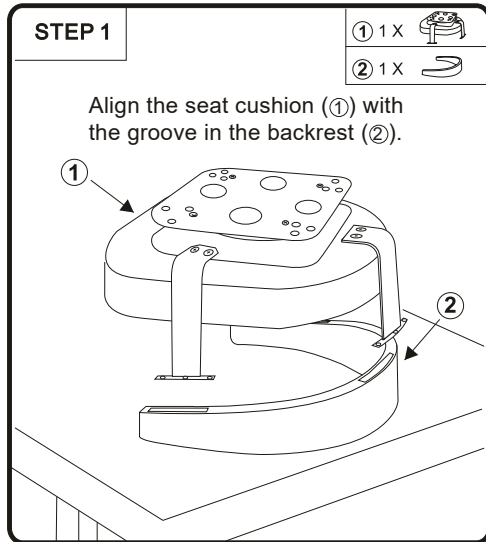

5

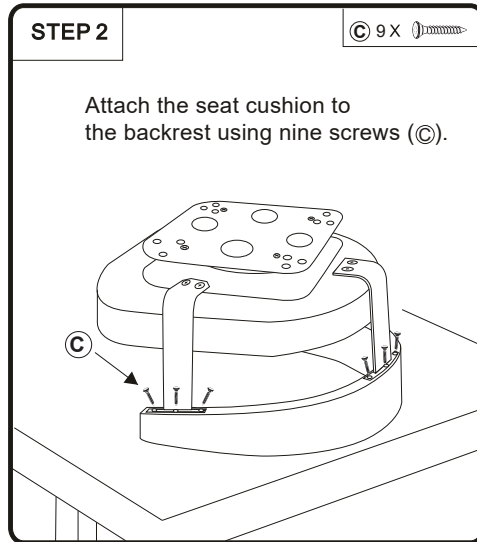

## ASSEMBLY INSTRUCTIONS

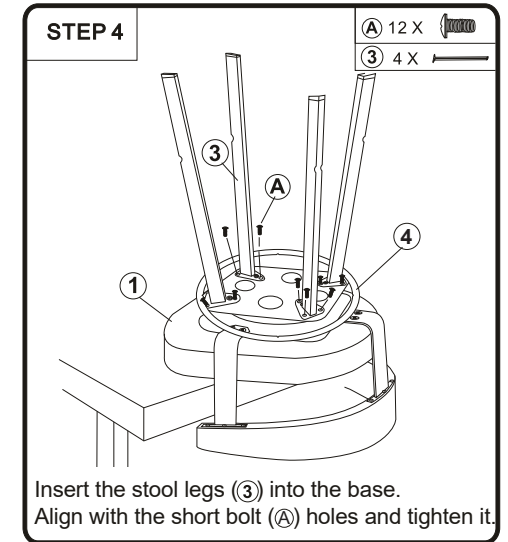
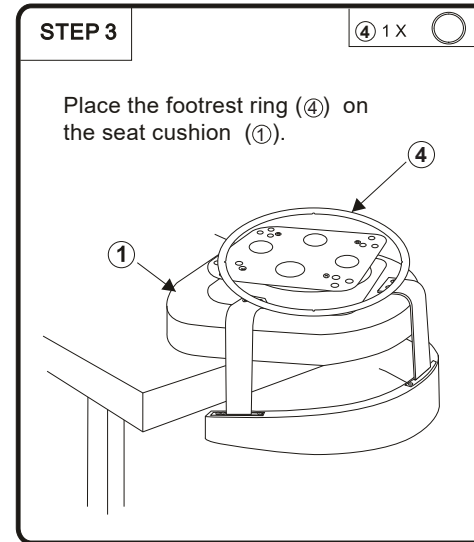

6

## ASSEMBLY INSTRUCTIONS

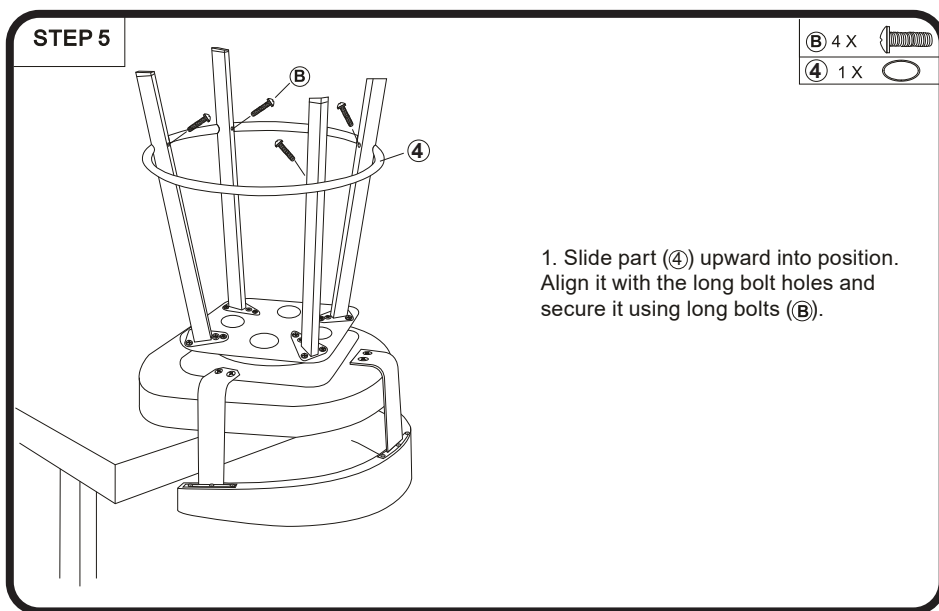

7

## LEVEL ADJUSTMENT INSTRUCTIONS

### 1. Factory Inspection

All products are thoroughly inspected before leaving the factory.

### 2. Possible Issues During Transport

Despite careful packaging, the base may shift slightly during shipping or handling—even if the box shows no visible damage.

### 3. How to Fix an Uneven Stool

- \* Place the stool on a flat, level surface.
- \* Hold one leg firmly.
- \* Gently tap the opposite leg against a piece of wood if needed.
- \* Check again to ensure the stool is level.

**⚠ Note: Repeat if needed. Avoid direct contact with hard surfaces to prevent damage.**

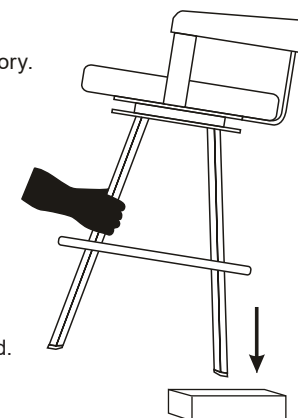

8

## CLEANING & CARE

### Keep Your Stool Looking Its Best

Wipe regularly with a soft, dry cloth to remove dust  
For deeper cleaning, use a soft cloth with warm, mild soapy water  
Always dry the surface thoroughly after cleaning

### Avoid Using Harsh or Abrasive Cleaning Products

- ✗ Strong chemical cleaners
- ✗ Abrasive or rough materials
- ✗ Glass cleaners (which may damage the finish)
- ✗ Waxes or oil-based products

## ⚠ WARNING



- Bar stools are tall and may swivel. Use caution to prevent falls or injuries.
- Do not leave children unattended on or near the stool.
- Regularly inspect the stool and tighten all screws, nuts, and bolts.
- If you notice a broken weld or bent leg, stop using the stool immediately and contact customer service.
- Failure to follow these instructions may result in product damage or personal injury.

## 10-YEAR LIMITED RESIDENTIAL WARRANTY

### What's Covered?

Metal frame & welding: 10 years warranty (residential use only) .  
Wood & upholstered parts: 1-year limited warranty.  
Covers defects in materials or workmanship under normal use.

### What's Not Covered?

The following are not considered defects:

- Normal wear and tear (scratches, paint fading, fabric aging)
- Damage caused by improper use or assembly
- Unauthorized repairs or modifications
- Shipping damage (unless specially packaged for direct delivery)

### Need Help? We've Got You Covered

If you experience any issues with your product, please contact us within 30 days of purchase and provide a brief description of the issue along with your proof of purchase (receipt or screenshot).

We may repair or replace defective parts at our discretion. Shipping costs are the customer's responsibility. Replacement parts are covered only for the remainder of the original warranty period and do not extend the warranty.