



ASSEMBLY INSTRUCTIONS

**KEEP THIS DOCUMENT FOR REFERENCE IN CASE PARTS ARE NEEDED
DO NOT TIGHTEN SCREWS UNTIL COMPLETELY ASSEMBLE !!**

NO.		PART LIST	QTY	NO.		HARDWARE LIST	QTY
A		NIGHTSTAND	1 PC	1		USB ADAPTER	1 PC

Notice: there is a USB device at the back side of the case, please connect the adapter to the USB cable then plug it into the electric outlet before using.

STEP 1

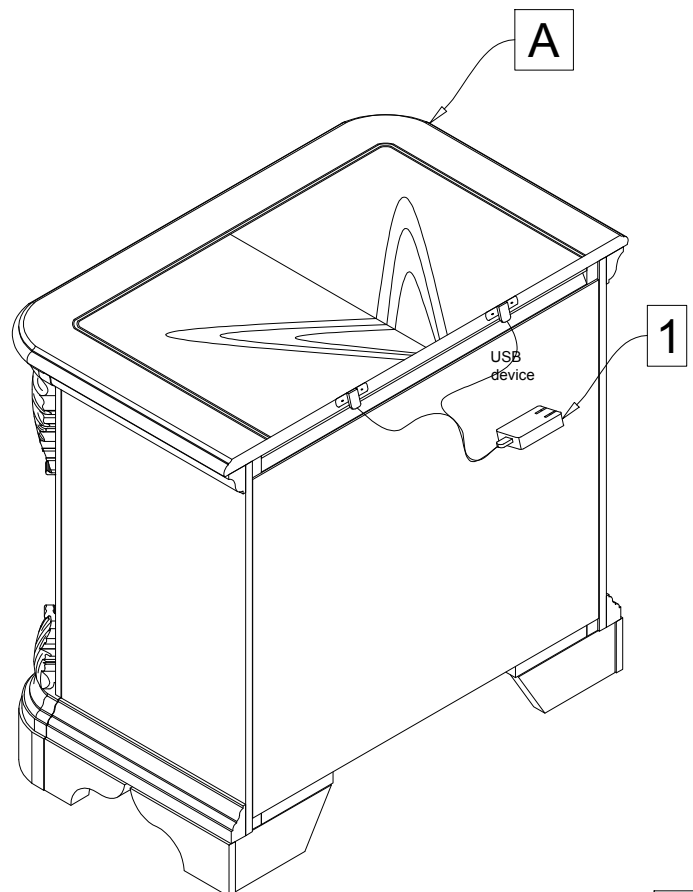
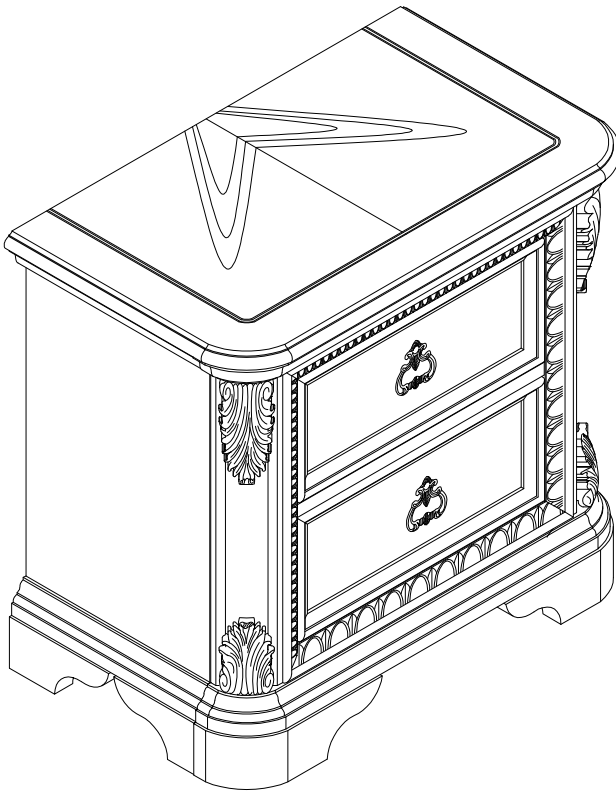

ASSEMBLY INSTRUCTIONS

**KEEP THIS DOCUMENT FOR REFERENCE IN CASE PARTS ARE NEEDED
DO NOT TIGHTEN SCREWS UNTIL COMPLETELY ASSEMBLE !!**

NO.		PART LIST	QTY
A		CHEST	1 PC

NO		HARDWARE LIST	QTY
1		ANTI-TIPPING KIT	1 PC

Remark: There is a tipping restraint kit attached to
★ the back of this product. Please read the directions
thoroughly and install immediately before use.

STEP 1

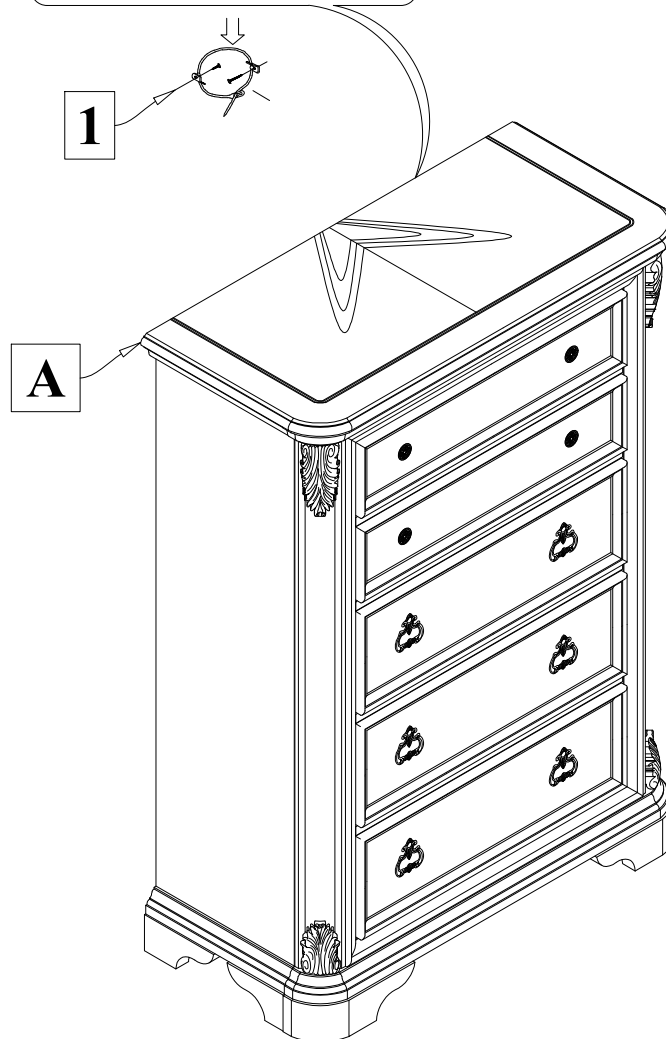

ASSEMBLY INSTRUCTIONS

**KEEP THIS DOCUMENT FOR REFERENCE IN CASE PARTS ARE NEEDED
DO NOT TIGHTEN SCREWS UNTIL COMPLETELY ASSEMBLE !!**

NO	PART LIST	QTY
A	 DRESSER	1 PC

NO	HARDWARE LIST	QTY
1	 ANTI-TIPPING KIT	1 PC



STEP 1

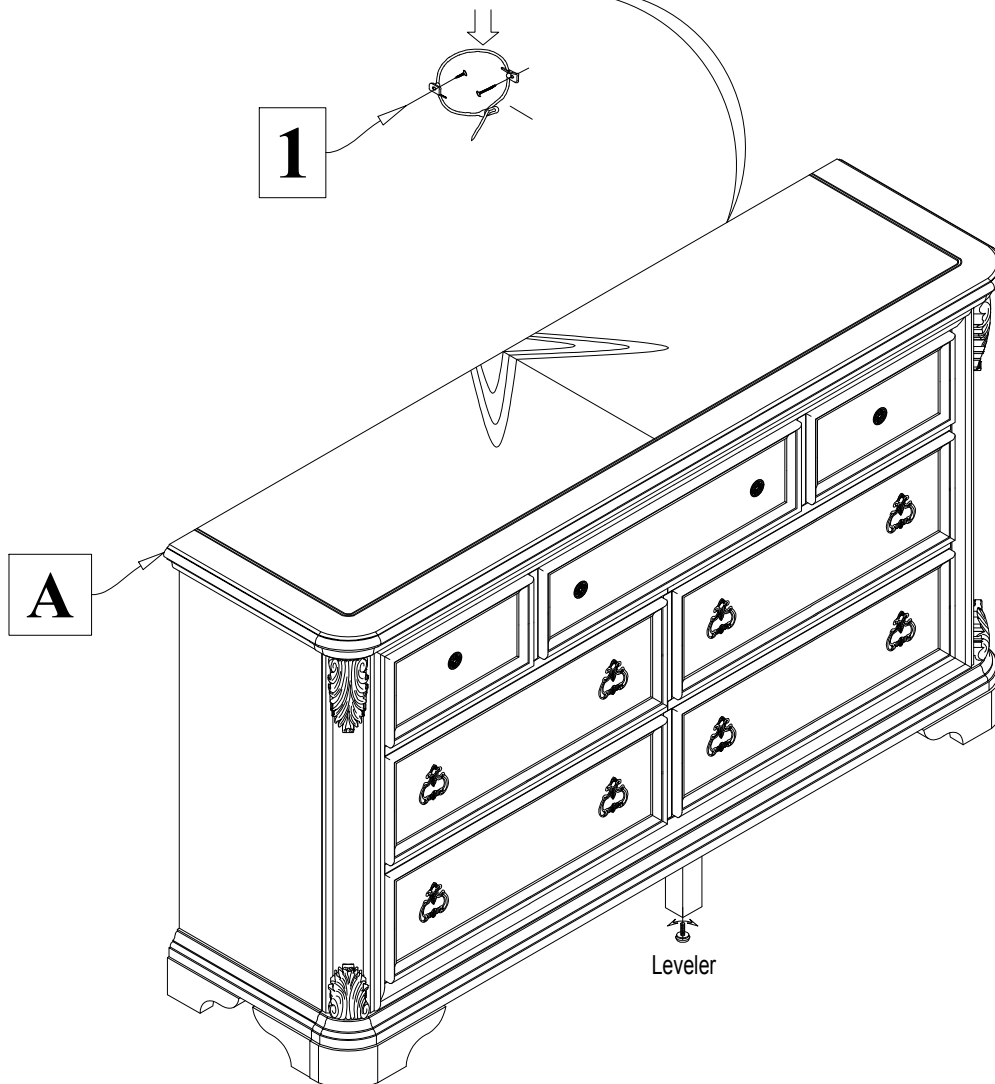



Remark: There is a tipping restraint kit attached to ★ the back of this product. Please read the directions thoroughly and install immediately before use.



ASSEMBLY INSTRUCTIONS

**KEEP THIS DOCUMENT FOR REFERENCE IN CASE PARTS ARE NEEDED
DO NOT TIGHTEN SCREWS UNTIL COMPLETELY ASSEMBLE !!**

NO	PART LIST	QTY
A	 DRESSER	1 PC
B	 MIRROR	1 PC
C	 MIRROR SUPPORT IN MIRROR BOX	2 PCS

NO	HARDWARE LIST		QTY
1		ALLEN KEY L57 x 4mm	1 PC
2		BOLT $\Phi 1/4" * 1 - 1/2"$	8 PCS
3		SPRING WASHER $\Phi 1/4" * 13 * 1.5\text{mm}$	8 PCS
4		FLAT WASHER $\Phi 1/4" * 19 * 1.5\text{mm}$	8 PCS

STEP 1

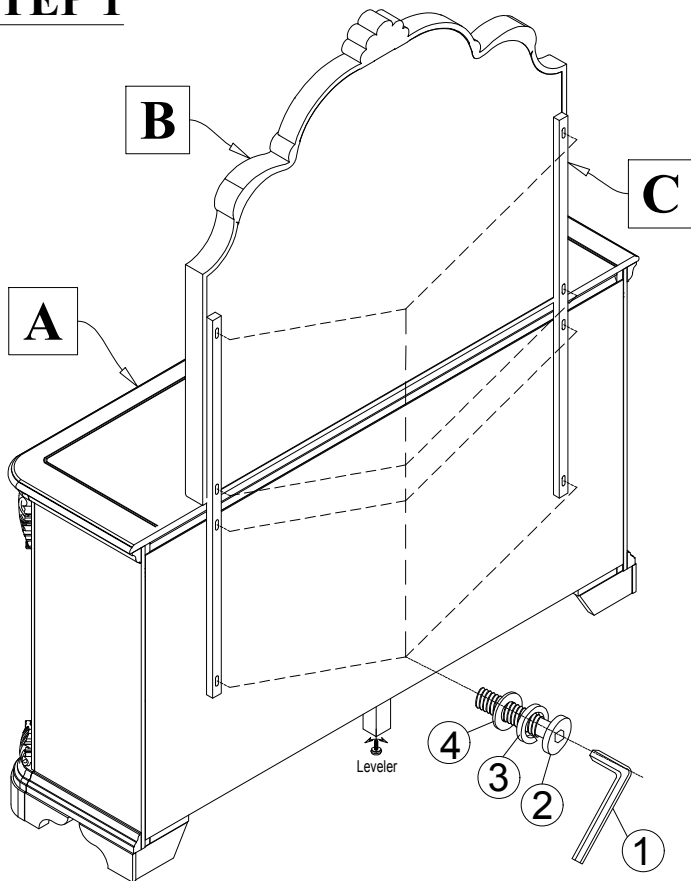



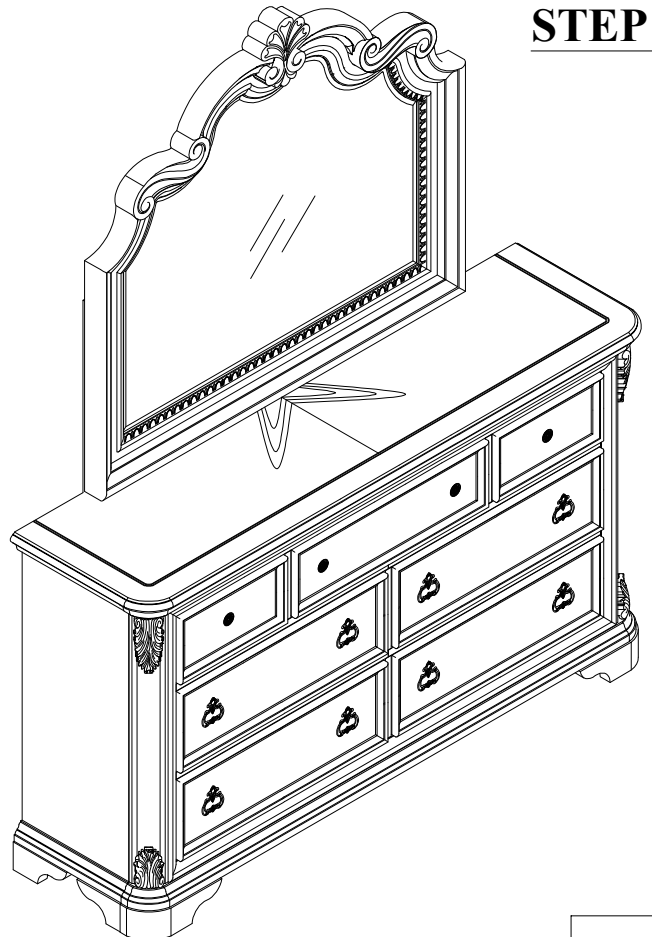







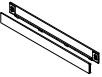









STEP 2



ASSEMBLY INSTRUCTIONS

**KEEP THIS DOCUMENT FOR REFERENCE IN CASE PARTS ARE NEEDED
DO NOT TIGHTEN SCREWS UNTIL COMPLETELY ASSEMBLE !!**

NO	PART LIST		QTY
A		King Headboard	1 PC
B		King Footboard	1 PC
C		Queen/King Side Rails (L/R)	2 PCS
D		Headboard Leg (L/R)	2 PCS
E		Stretcher	1 PC
F		Slat	4 PCS
G		Support Leg	8 PCS

NO	HARDWARE LIST			QTY
1		ALLEN KEY	L57 x 4mm	1 PC
2		BOLT	Φ1/4"*1 - 1/2"	2 PCS
3		SPRING WASHER	Φ1/4"*13*1.2mm	2 PCS
4		FLAT WASHER	Φ1/4"*19*1.8mm	2 PCS
5		BOLT	Φ5/16"*2-1/4"	6 PCS
6		SPRING WASHER	Φ5/16"*13*1.2mm	6 PCS
7		FLAT WASHER	Φ5/16"*19*1.8mm	6 PCS
* Above Hardware packed in 1988/1989-112HK for assembly.				
8		BOLT	Φ5/16"*3"	8 PCS
9		"C" WASHER	Φ5/16"	8 PCS
10		SPRING WASHER	Φ5/16"*13*1.2mm	8 PCS
11		NUT	Φ5/16"*16mm	8 PCS
12		HEX WRENCH		1 PC
* Above Hardware packed in 1988/1989-106RL for assembly.				
13		SCREW/ VIS	#8*30mm	8 PCS
* Above Hardware packed in 1988/1989-110FK for assembly.				

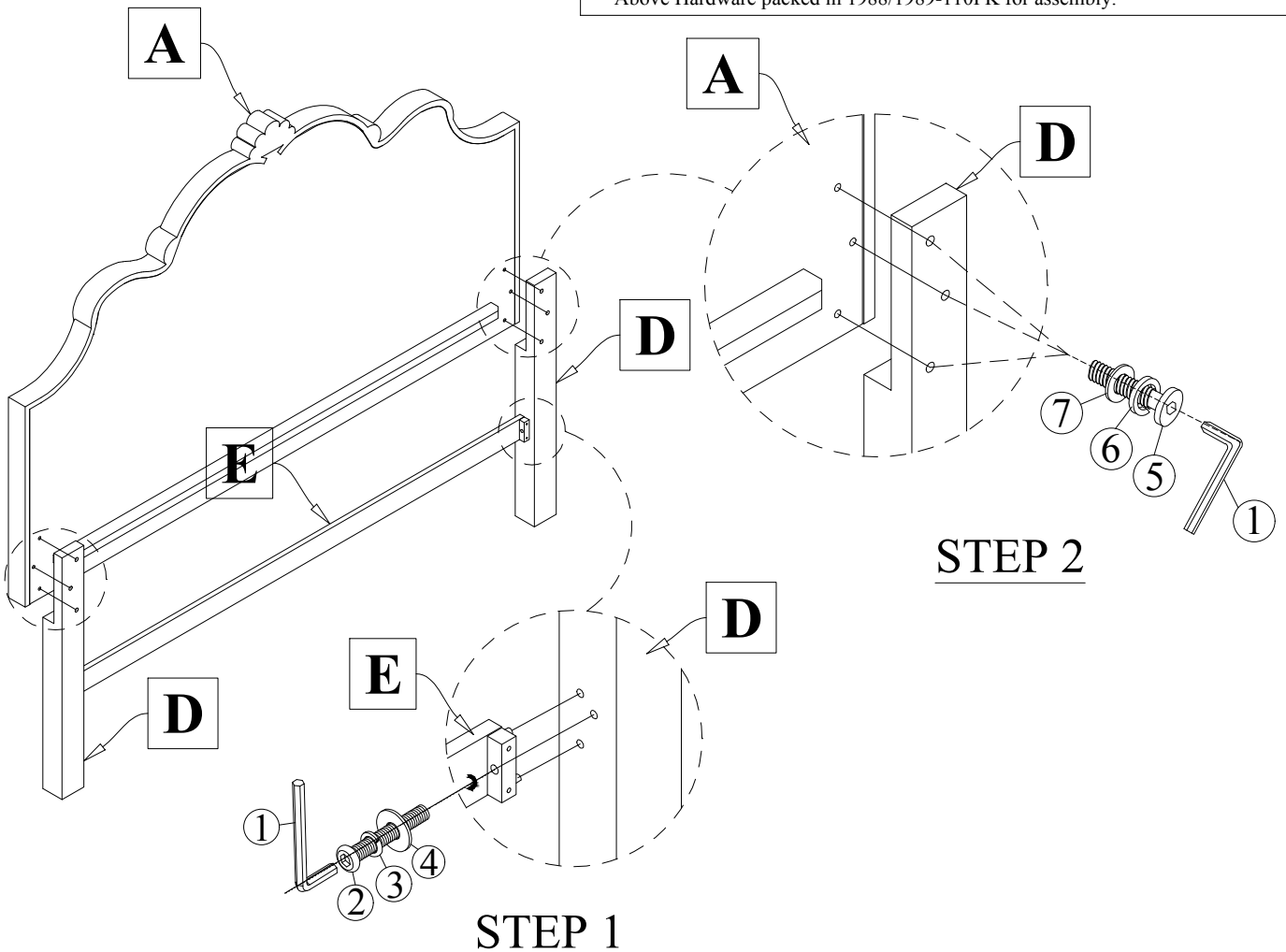



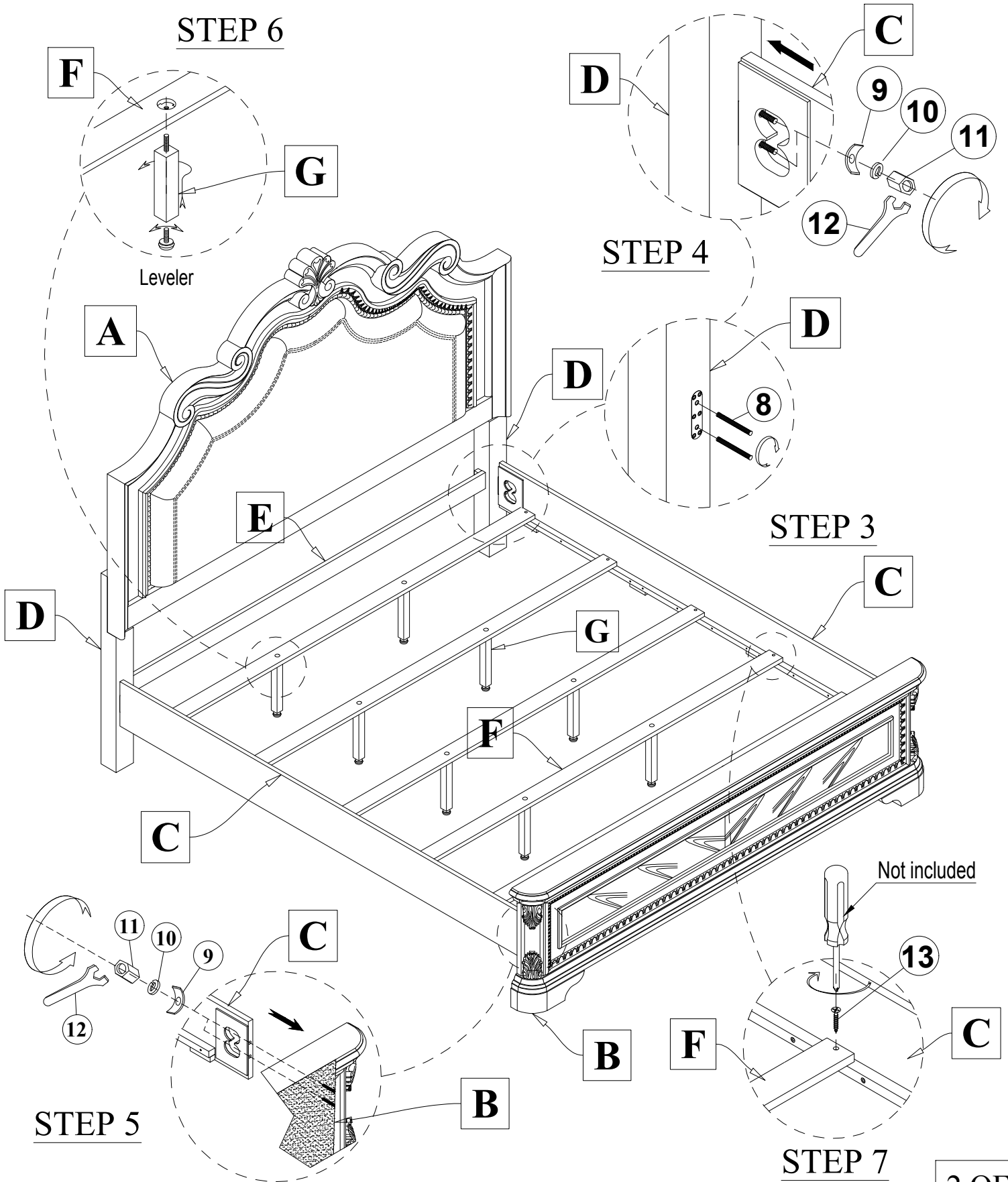









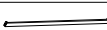







ASSEMBLY INSTRUCTIONS



ASSEMBLY INSTRUCTIONS

**KEEP THIS DOCUMENT FOR REFERENCE IN CASE PARTS ARE NEEDED
DO NOT TIGHTEN SCREWS UNTIL COMPLETELY ASSEMBLE !!**

NO	PART LIST		QTY
A		Queen Headboard	1 PC
B		Queen Footboard	1 PC
C		Queen/King Side Rails (L/R)	2 PCS
D		Headboard Leg (L/R)	2 PCS
E		Stretchers	1 PC
F		Slat	4 PCS
G		Support Leg	4 PCS

NO	HARDWARE LIST			QTY
1		ALLEN KEY	L57 x 4mm	1 PC
2		BOLT	Φ1/4"*1 - 1/2"	2 PCS
3		SPRING WASHER	Φ1/4"*13*1.2mm	2 PCS
4		FLAT WASHER	Φ1/4"*19*1.8mm	2 PCS
5		BOLT	Φ5/16"*2-1/4"	6 PCS
6		SPRING WASHER	Φ5/16"*13*1.2mm	6 PCS
7		FLAT WASHER	Φ5/16"*19*1.8mm	6 PCS
* Above Hardware packed in 1988/1989-107HQ for assembly.				
8		BOLT	Φ5/16"*3"	8 PCS
9		"C" WASHER	Φ5/16"	8 PCS
10		SPRING WASHER	Φ5/16"*13*1.2mm	8 PCS
11		NUT	Φ5/16"*16mm	8 PCS
12		HEX WRENCH		1 PC
* Above Hardware packed in 1988/1989-106RL for assembly.				
13		SCREW/ VIS	#8*30mm	8 PCS
* Above Hardware packed in 1988/1989-105FQ for assembly.				

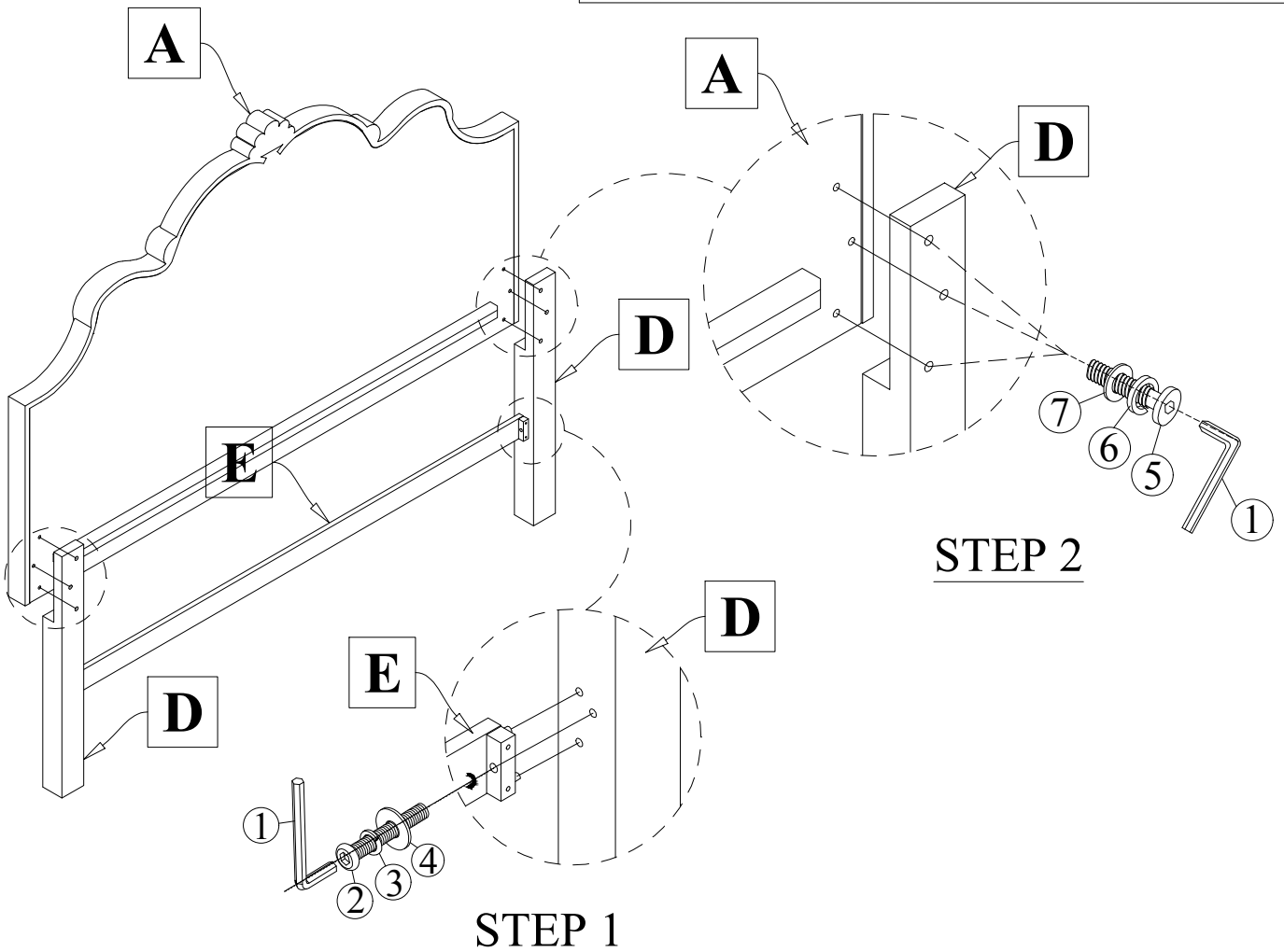

ASSEMBLY INSTRUCTIONS

STEP 6

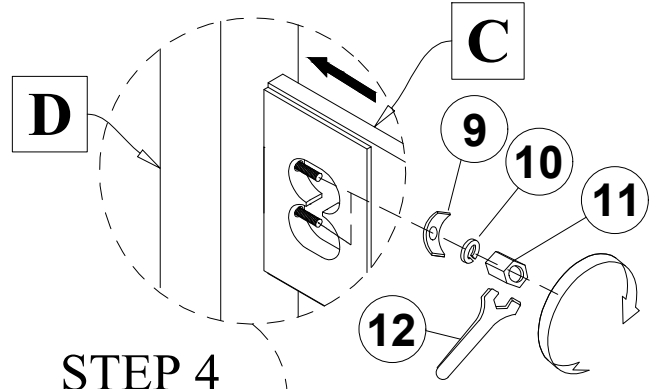
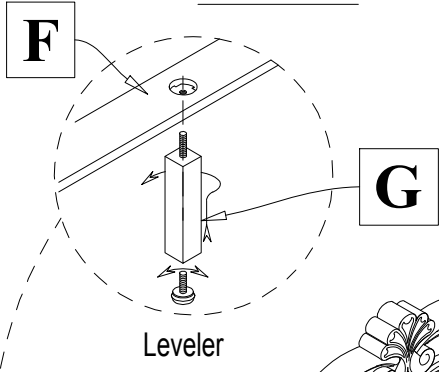

STEP 4

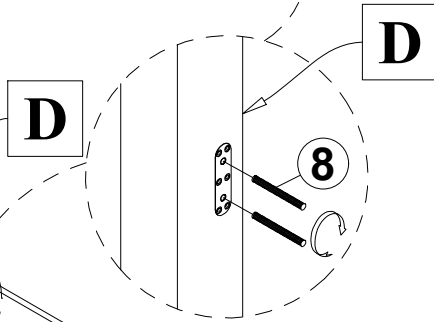

STEP 3

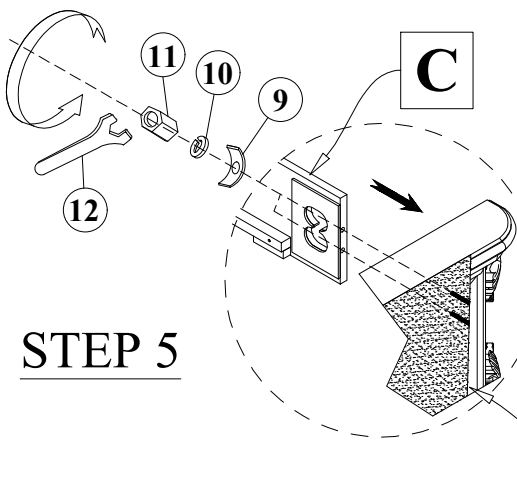
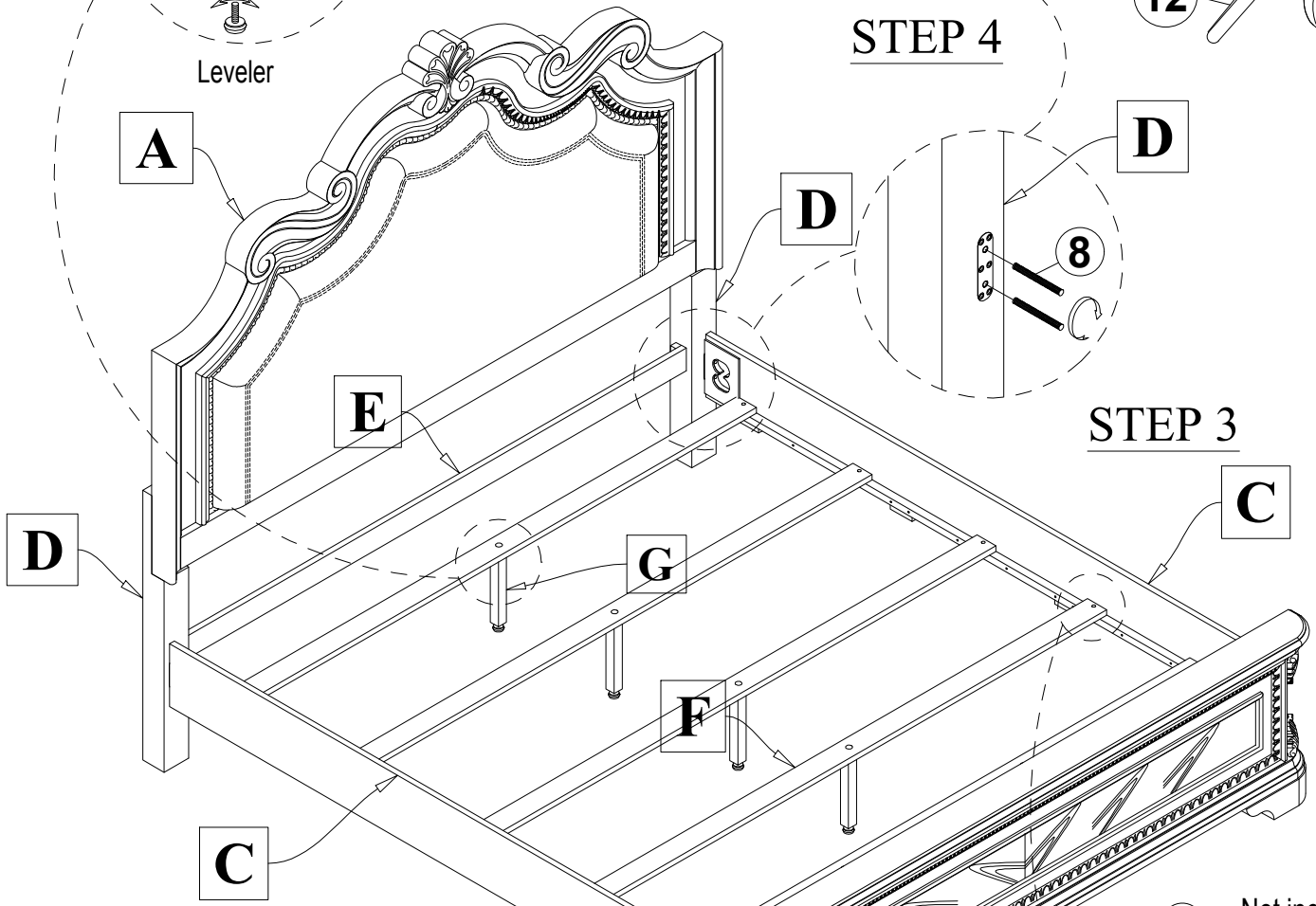



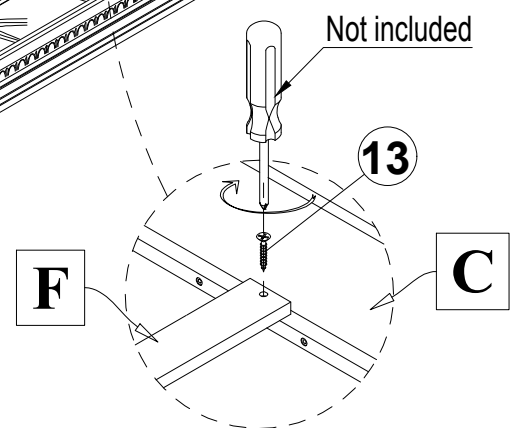







STEP 5



STEP 7

ASSEMBLY INSTRUCTIONS

**KEEP THIS DOCUMENT FOR REFERENCE IN CASE PARTS ARE NEEDED
DO NOT TIGHTEN SCREWS UNTIL COMPLETELY ASSEMBLE !!**

NO	PART LIST		QTY
A		King Headboard	1 PC
B		King Footboard	1 PC
C		Queen/King Side Rails (L/R)	2 PCS
D		Headboard Post (L/R)	2 PCS
E		Footboard Post (L/R)	2 PCS
F		Slat	4 PCS
G		Support Leg	8PCS
H		Canopy corner	4PCS
I		Canopy panel (Top and Bottom)	2PCS
K		Canopy side panels	2PCS

NO	HARDWARE LIST			QTY
1		ALLEN KEY	L57 x 4mm	1 PC
2		BOLT	Φ5/16"*2-1/4"	8 PCS
3		SPRING WASHER	Φ5/16"*13*1.2mm	8 PCS
4		FLAT WASHER	Φ5/16"*19*1.8mm	8 PCS
* Above Hardware packed in 1988/1989-113HK for assembly.				
5		ALLEN KEY	L57 x 4mm	1 PC
6		BOLT	Φ5/16"*2-1/4"	6 PCS
7		SPRING WASHER	Φ5/16"*13*1.2mm	6 PCS
8		FLAT WASHER	Φ5/16"*19*1.8mm	6 PCS
9		SCREW/ VIS	#8*30mm	8 PCS
* Above Hardware packed in 1988/1989-111FK for assembly.				
10		BOLT	Φ5/16"*3"	8 PCS
11		"C" WASHER	Φ5/16"	8 PCS
12		SPRING WASHER	Φ5/16"*13*1.2mm	8 PCS
13		NUT	Φ5/16"*16mm	8 PCS
14		HEX WRENCH		1 PC
* Above Hardware packed in 1988/1989-106RL for assembly.				
15		ALLEN KEY	L57 x 4mm	1 PC
16		BOLT	Φ1/4"*5/8"	16 PCS
17		SPRING WASHER	Φ1/4"*13*1.2mm	16 PCS
18		FLAT WASHER	Φ1/4"*16*1.8mm	16 PCS
* Above Hardware packed in 1988/1989-111CAN for assembly.				

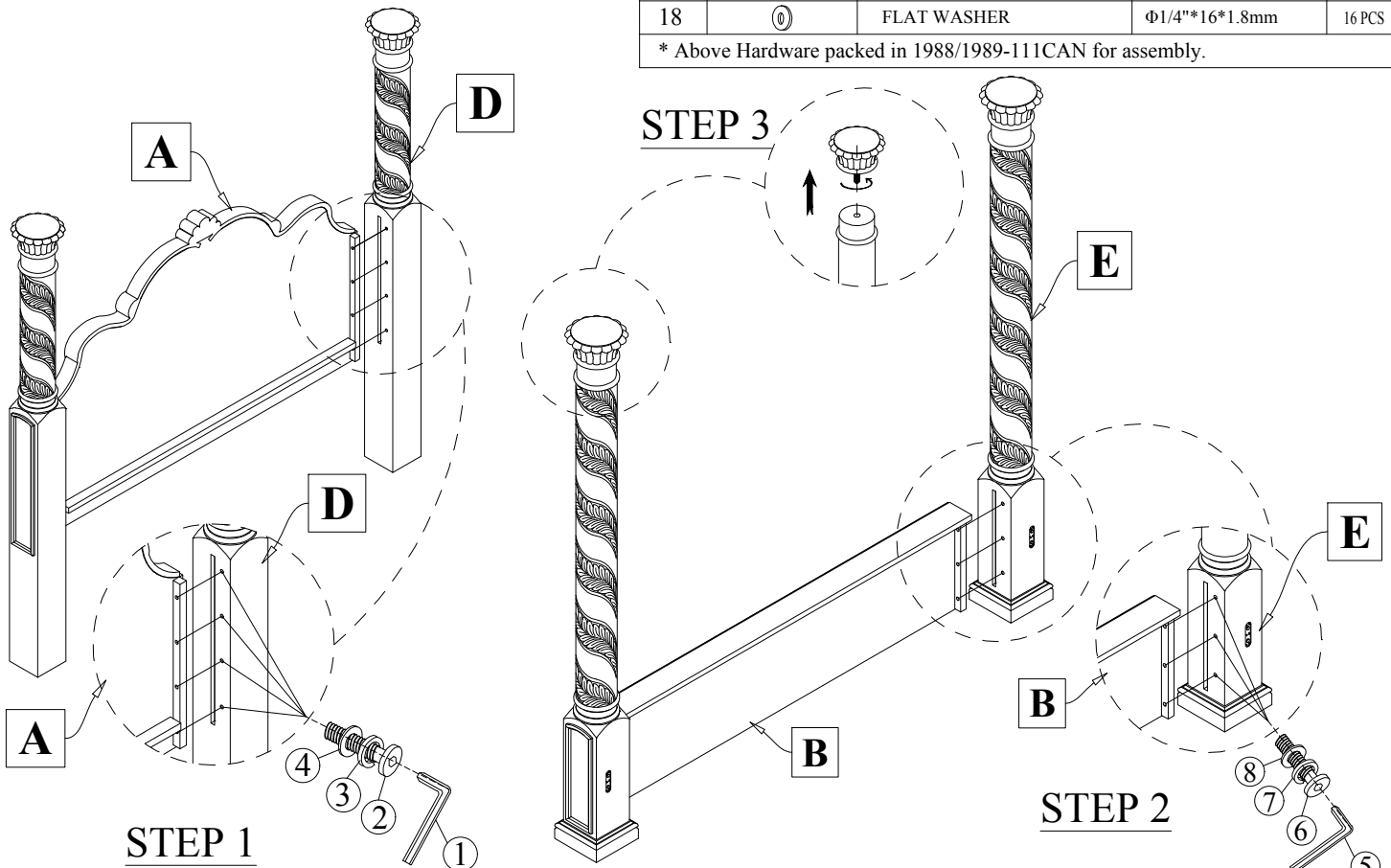



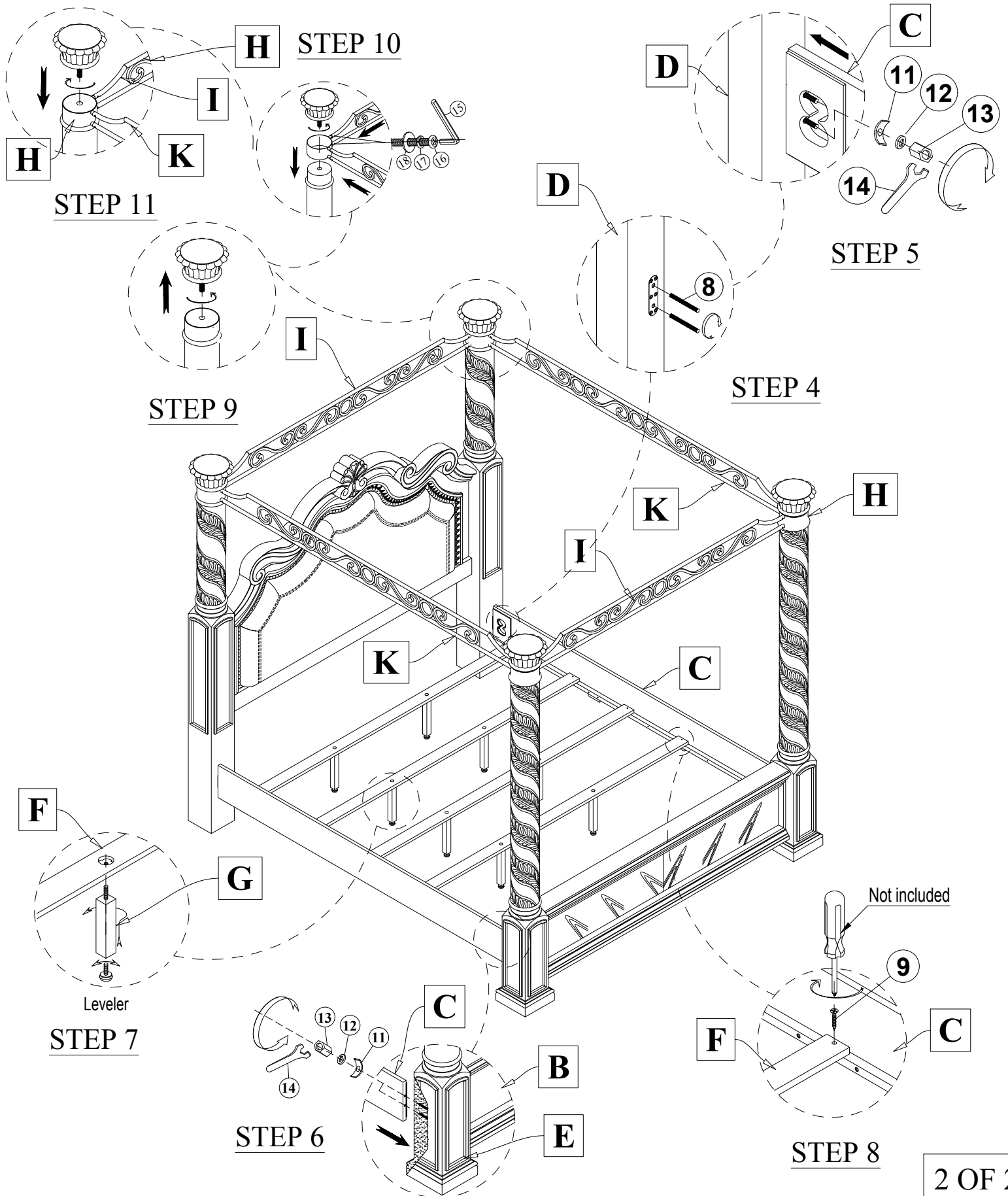







ASSEMBLY INSTRUCTIONS



ASSEMBLY INSTRUCTIONS

**KEEP THIS DOCUMENT FOR REFERENCE IN CASE PARTS ARE NEEDED
DO NOT TIGHTEN SCREWS UNTIL COMPLETELY ASSEMBLE !!**

NO	PART LIST		QTY
A		Queen Headboard	1 PC
B		Queen Footboard	1 PC
C		Queen/King Side Rails (L/R)	2 PCS
D		Headboard Post (L/R)	2 PCS
E		Footboard Post (L/R)	2 PCS
F		Slat	4 PCS
G		Support Leg	4 PCS
H		Canopy corner	4PCS
I		Canopy panel (Top and Bottom)	2PCS
K		Canopy side panels	2PCS

NO	HARDWARE LIST			QTY
1		ALLEN KEY	L57 x 4mm	1 PC
2		BOLT	Φ5/16"*2-1/4"	8 PCS
3		SPRING WASHER	Φ5/16"*13*1.2mm	8 PCS
4		FLAT WASHER	Φ5/16"*19*1.8mm	8 PCS
* Above Hardware packed in 1988/1989-108HQ for assembly.				
5		ALLEN KEY	L57 x 4mm	1 PC
6		BOLT	Φ5/16"*2-1/4"	6 PCS
7		SPRING WASHER	Φ5/16"*13*1.2mm	6 PCS
8		FLAT WASHER	Φ5/16"*19*1.8mm	6 PCS
9		SCREW/ VIS	#8*30mm	8 PCS
* Above Hardware packed in 1988/1989-106FQ for assembly.				
10		BOLT	Φ5/16"*3"	8 PCS
11		"C" WASHER	Φ5/16"	8 PCS
12		SPRING WASHER	Φ5/16"*13*1.2mm	8 PCS
13		NUT	Φ5/16"*16mm	8 PCS
14		HEX WRENCH		1 PC
* Above Hardware packed in 1988/1989-106RL for assembly.				
15		ALLEN KEY	L57 x 4mm	1 PC
16		BOLT	Φ1/4"*5/8"	16 PCS
17		SPRING WASHER	Φ1/4"*13*1.2mm	16 PCS
18		FLAT WASHER	Φ1/4"*16*1.8mm	16 PCS
* Above Hardware packed in 1988/1989-106CAN for assembly.				

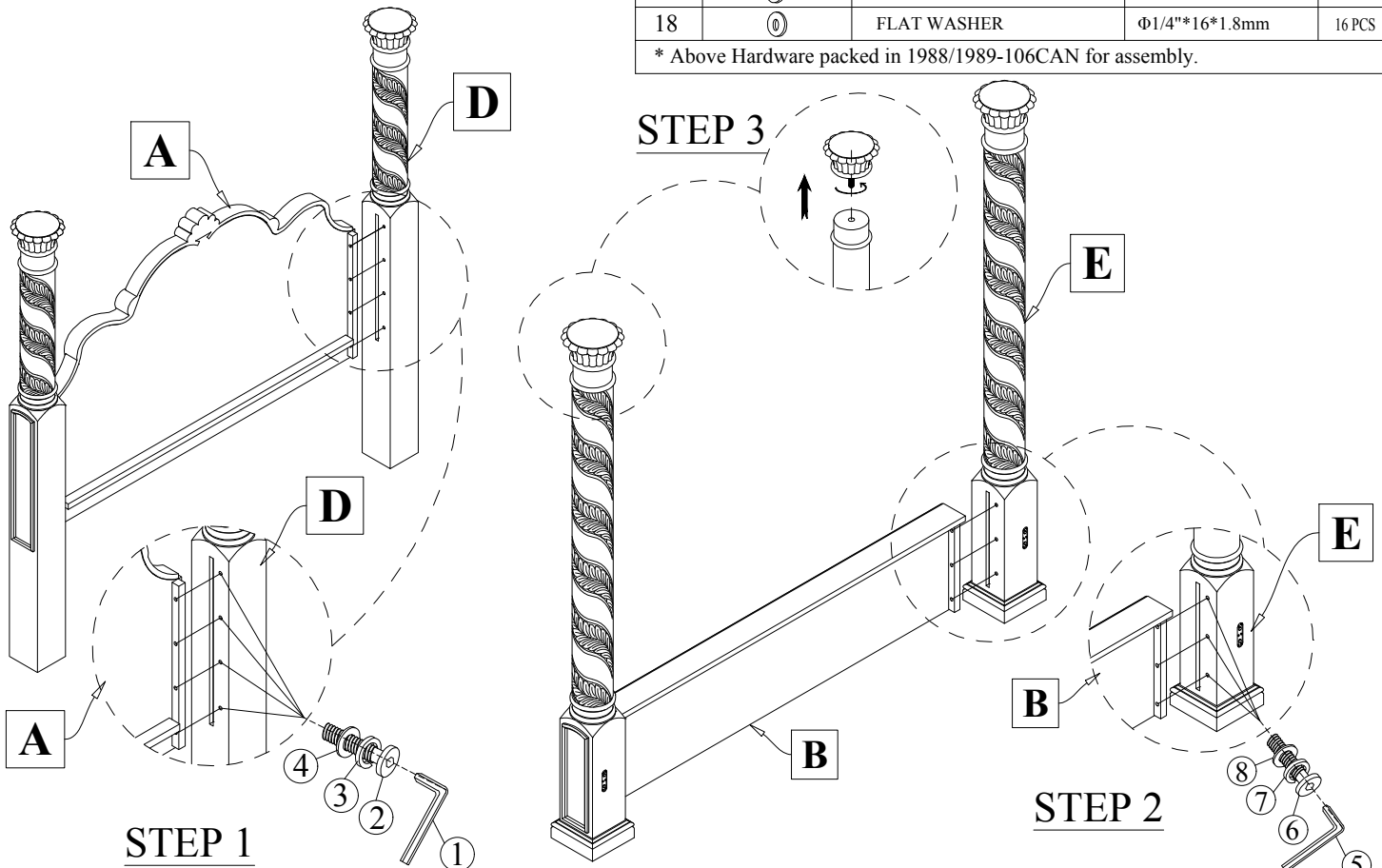

ASSEMBLY INSTRUCTIONS

