

Installation Instruction

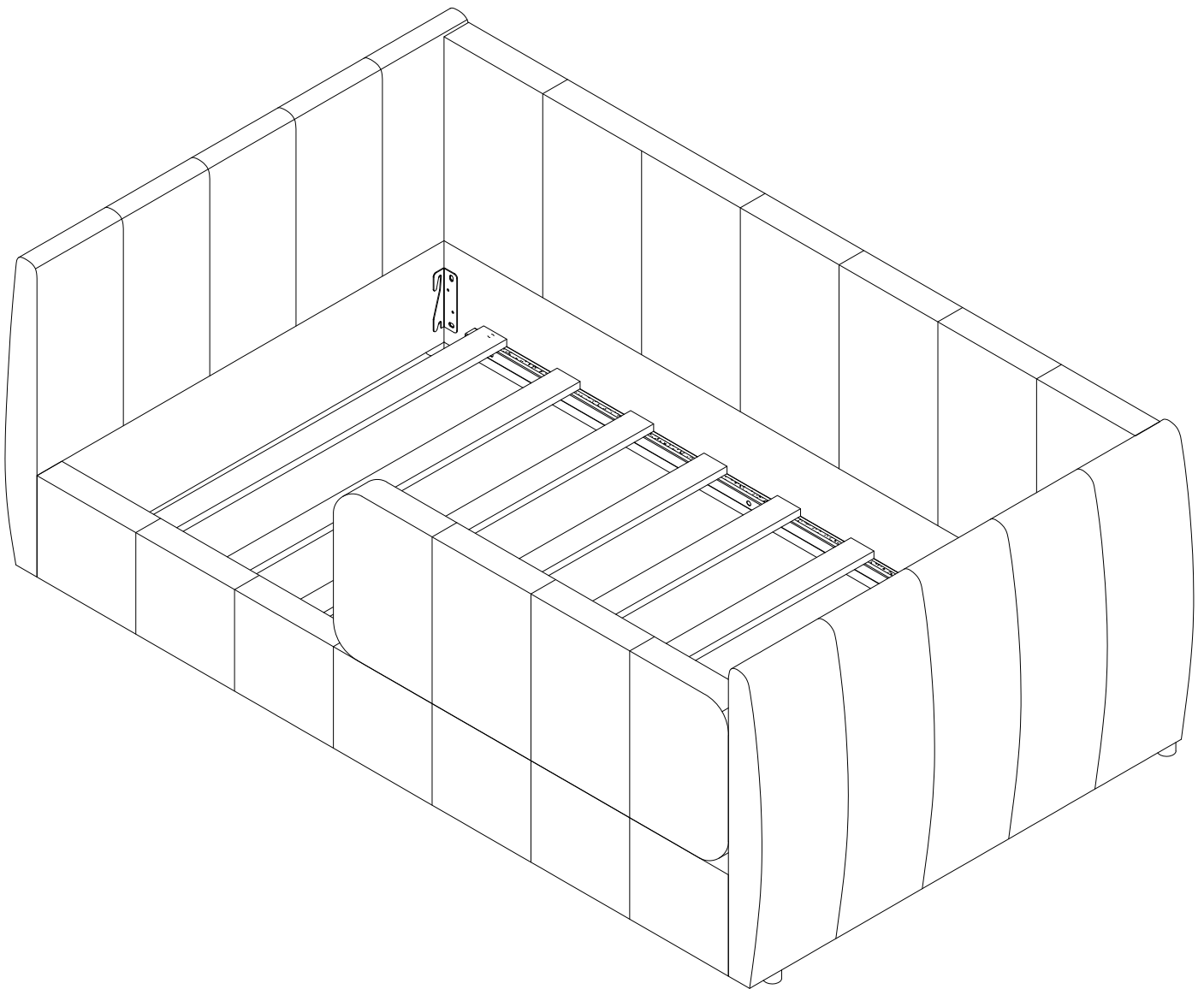

BED SAFETY WARNINGS

WARNING - STRANGULATION HAZARD

NEVER place bed near windows where cords from blinds or drapes may strangle a child.

NEVER suspend strings over bed.

NEVER place items with a string, cord, or ribbon, such as hood strings or pacifier cords, around a child's neck. These items may catch on bed parts.

WARNING - ENTRAPMENT HAZARD

INFANTS HAVE DIED IN TODDLER BEDS FROM ENTRAPMENT.

Openings in and between bed parts can entrap head and neck of a small child.

NEVER use bed with children younger than 15 months.

ALWAYS follow assembly instructions.

CAUTION - ENTRAPMENT HAZARD

To avoid dangerous gaps, any mattress used in this bed shall be a full-size crib mattress at least 51 ¼ in.(1310 mm) in length, 27 ¼ in. (690mm) in width, and a max thickness of 5 in.(127mm).

IMPORTANT ! KEEP FOR FUTURE REFERENCE : READ CAREFULLY

- To be assembled by an adult. Assembly must be checked by an adult before use
- **WARNING !** Keep all screws, small parts and plastic bags out of the reach of children
- Properly identify all parts before assembling
- Never use your item if any of its parts are broken or missing
- Should any problems arise, please contact our After Sales Service
- Manufacturer's instructions shall be followed at all times
- Care: Clean with a soft, dry cloth. In case of larger stains, carefully rub with a slightly damp, non-abrasive sponge
- Avoid the risk of fire by not placing furniture near sources of ignition or hot items
- Do not jump on the bed

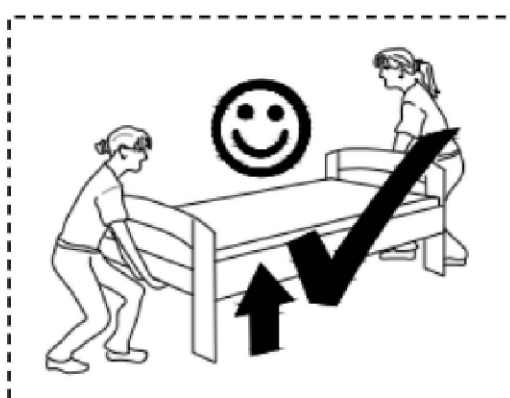
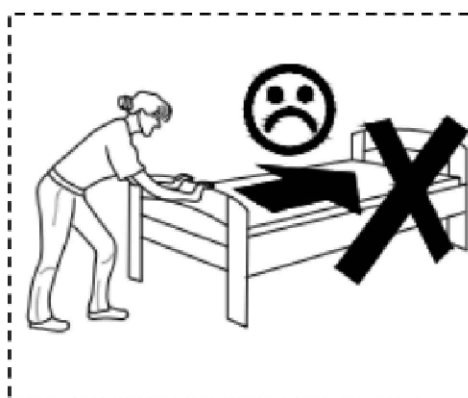

FR

Cet appareil,
ses cordons,
et batterie
se recyclent

À DÉPOSER
EN MAGASIN



À DÉPOSER
EN DÉCHÈTERIE



OU

Points de collecte sur www.quefairedemesdechets.fr
Privilégiez la réparation ou le don de votre appareil !

Note:

1. Should be assembled on flat ground to keep balance.
2. Before completing the installation, do not tighten the screws.

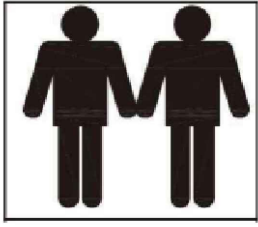



It needs at least two people
Before starting to install.

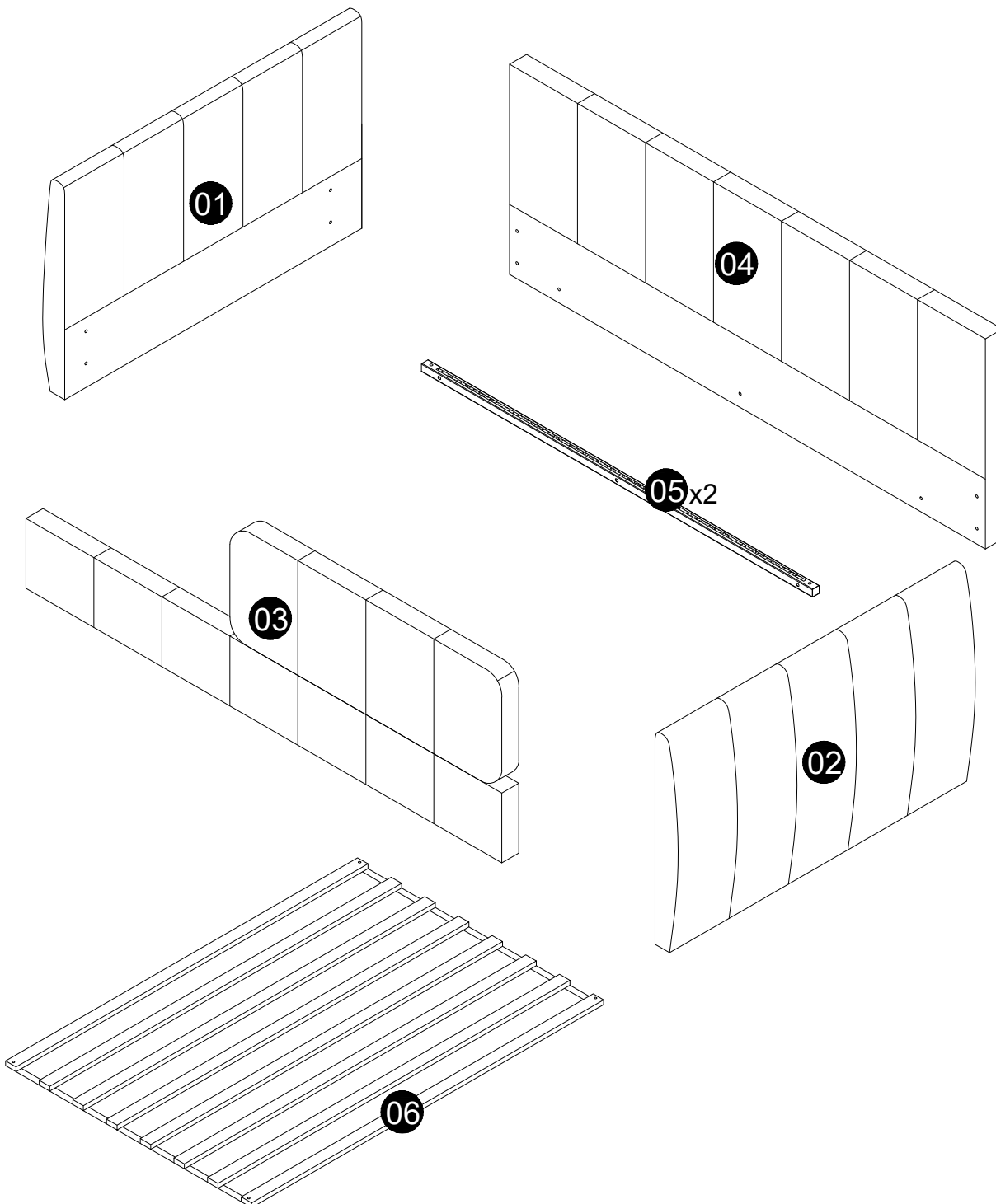

Before starting the
assembly, you must
read the whole
manual and follow
the instructions



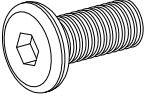
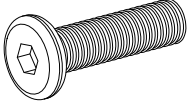
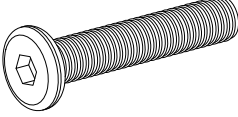
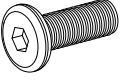
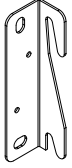

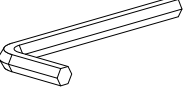
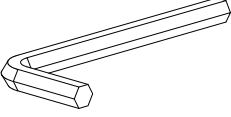
HARDWARE LIST

<h2 style="margin: 0;">A</h2>  <p style="margin: 10px 0;">8*20mm 16PCS</p>	<h2 style="margin: 0;">B</h2>  <p style="margin: 10px 0;">8*40mm 4PCS</p>	<h2 style="margin: 0;">C</h2>  <p style="margin: 10px 0;">8*50mm 6PCS</p>	<h2 style="margin: 0;">D</h2>  <p style="margin: 10px 0;">6*25mm 4PCS</p>
<h2 style="margin: 0;">E</h2>  <p style="margin: 10px 0;">2PCS</p>	<h2 style="margin: 0;">F</h2>  <p style="margin: 10px 0;">2PCS</p>	<h2 style="margin: 0;">G</h2>  <p style="margin: 10px 0;">2.5cm 4PCS</p>	<h2 style="margin: 0;">H</h2>  <p style="margin: 10px 0;">M6 1PC</p>
<h2 style="margin: 0;">I</h2>  <p style="margin: 10px 0;">M8 1PC</p>			

Before installation, insert the screws into the holes and tighten them, but do not tighten them to 100%, 70% to 80% is sufficient. Finally, after all screws are installed, tighten all screws to 100%. If you encounter these issues, such as if the holes cannot be aligned or some parts cannot be installed, please check if the screws are used correctly and adjust the tightness of the screws.

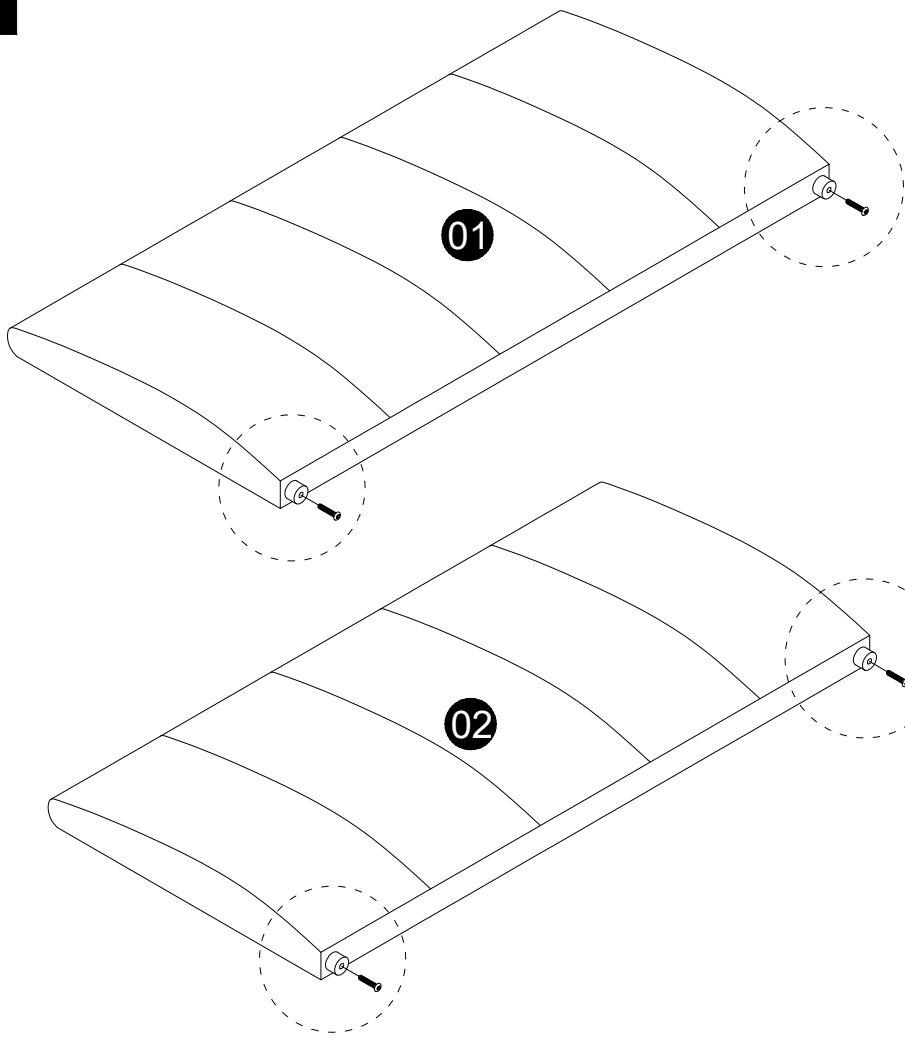
1



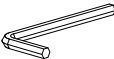

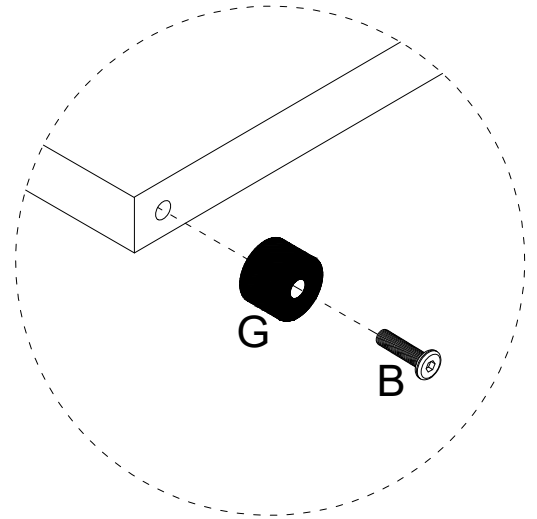
B		8*40mm	4pcs
G		2.5cm	4pcs
I		M8	1pc



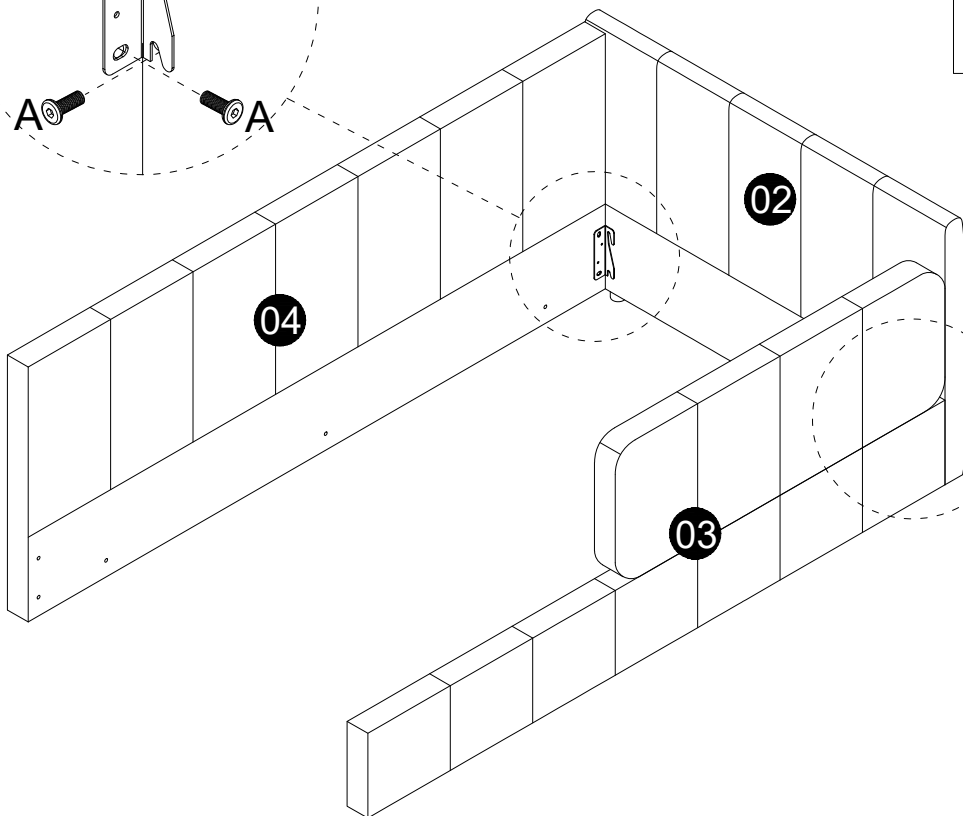
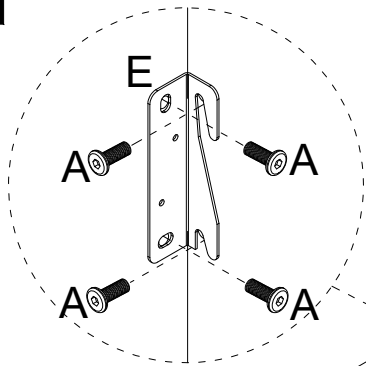

2

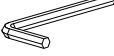

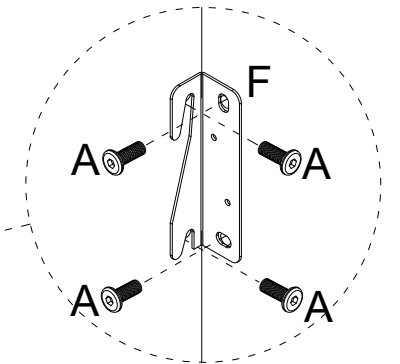
A		8*20mm	8pcs
E			1pc
F			1pc
I		M8	1pc

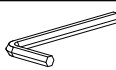

3

A		8*20mm	8 pcs
E			1 pc
F			1 pc
I		M8	1 pc

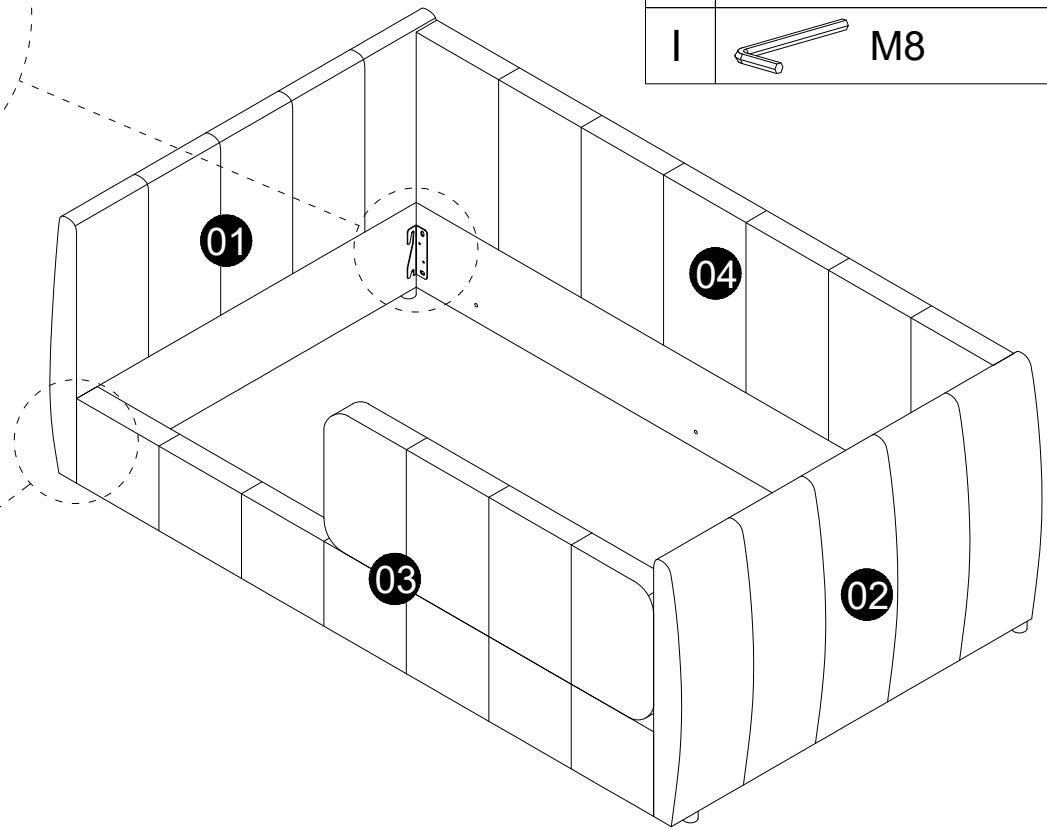
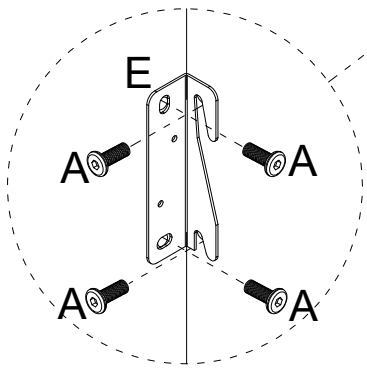
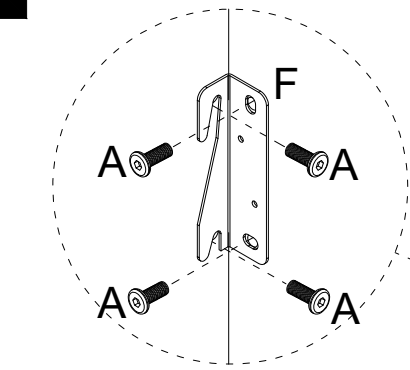

4

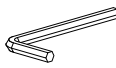

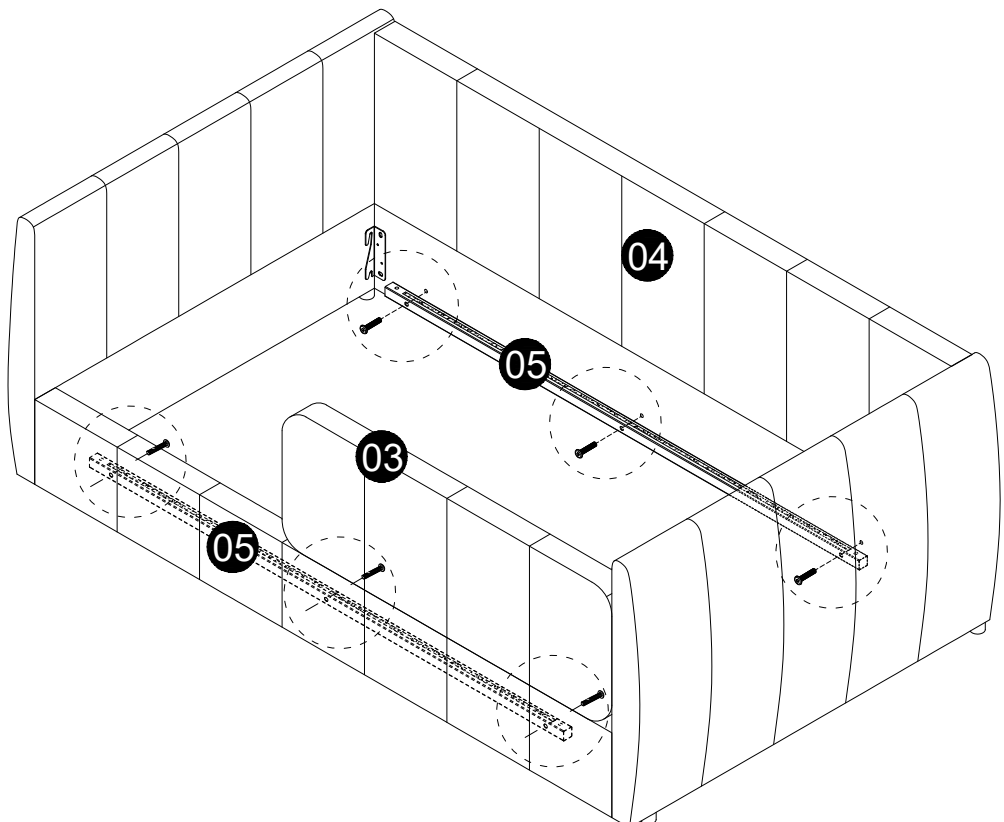
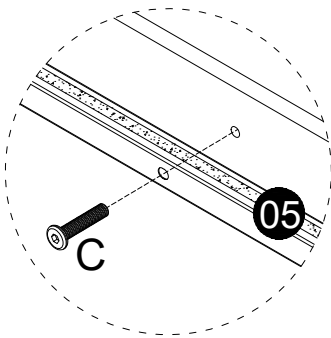
C		8*50mm	6 pcs
I		M8	1 pc

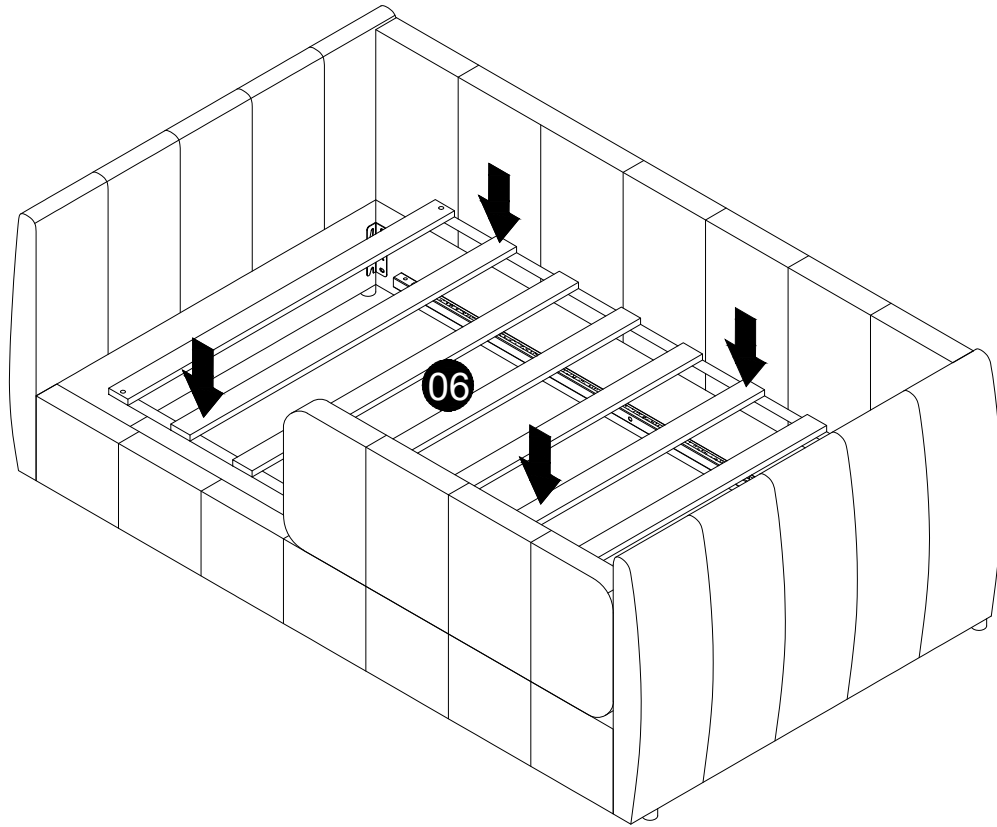

5



6

D		6*25mm	4pcs
H		M6	1pc

