







ASSEMBLY INSTRUCTIONS

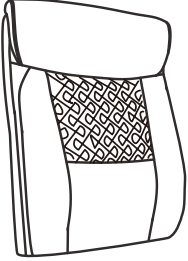

Components List [Teileliste]

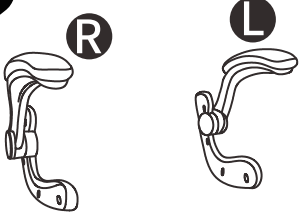
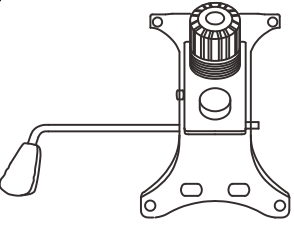
If you find any missing parts, please let us know, and we will send them to you as soon as possible.

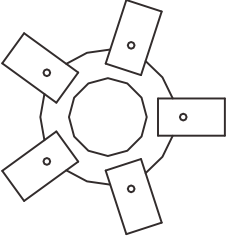
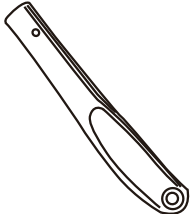
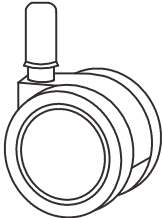
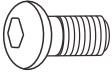
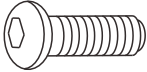
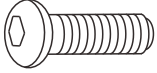
Wenn Sie fehlende Teile feststellen, lassen Sie es uns bitte wissen, und wir werden sie Ihnen so schnell wie möglich zusenden.

<p>A</p>  <p>X1</p>	<p>B</p>  <p>X1</p>	<p>C</p>  <p>X2</p>
<p>D</p>  <p>X1</p>	<p>E</p>  <p>X1</p>	<p>F</p>  <p>X1</p>
<p>G</p>  <p>X1</p>	<p>H</p>  <p>X5</p>	<p>I</p>  <p>X5</p>
<p>1</p>  <p>M6*16mm X5</p>	<p>2</p>  <p>M6*20mm X4</p>	<p>3</p>  <p>M6*25mm X8</p>
<p>4</p>  <p>X1</p>	<p>5</p>  <p>X8</p>	

Installation steps [Installationsschritte]

1.

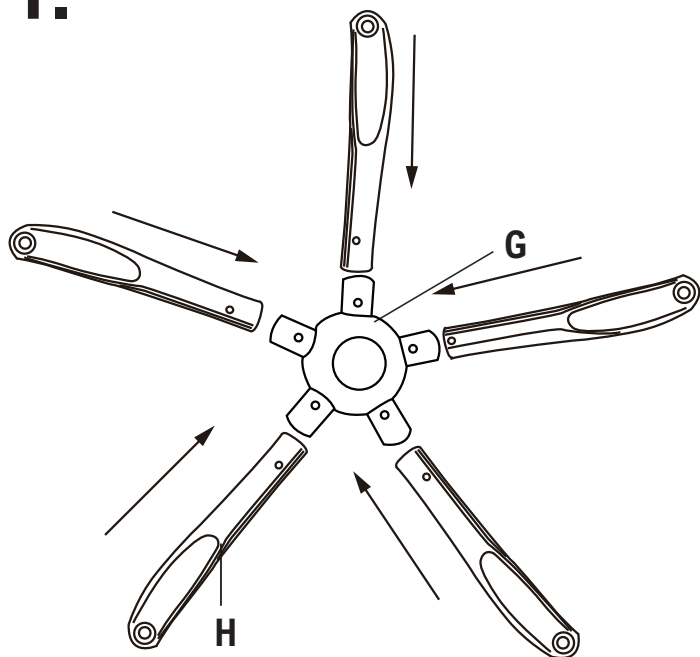

2.

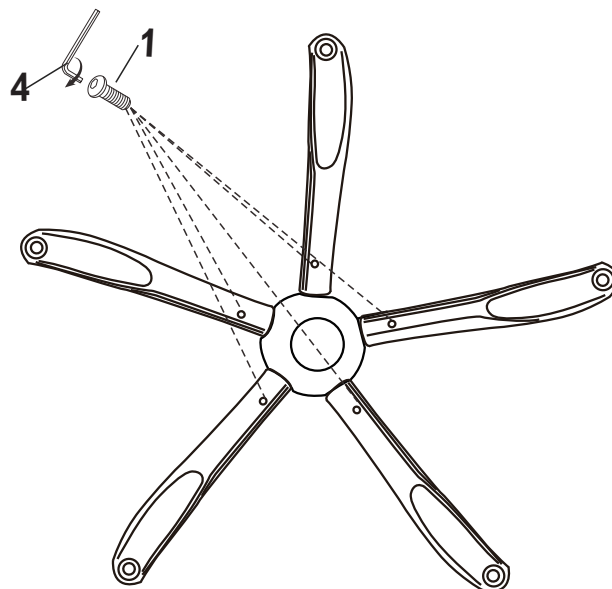

3.

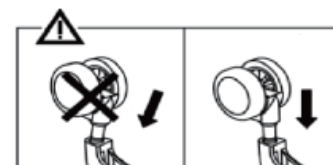
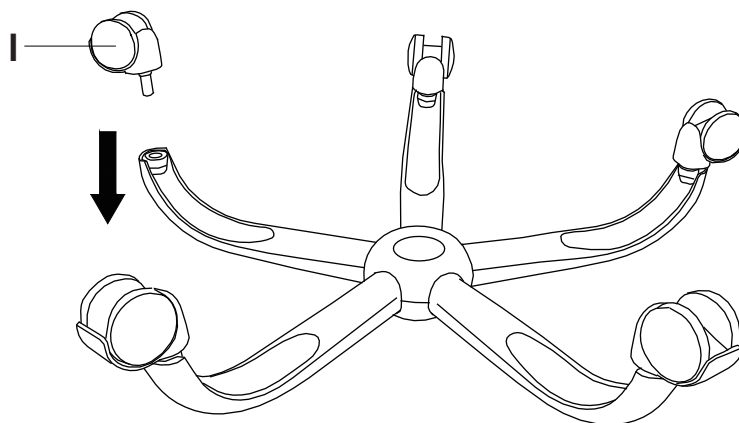
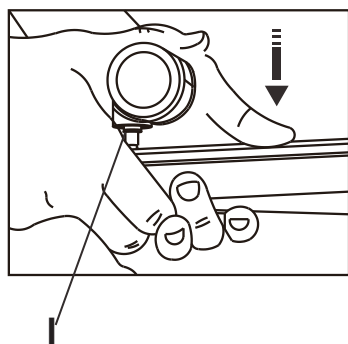

Installation steps [Installationsschritte]

4.

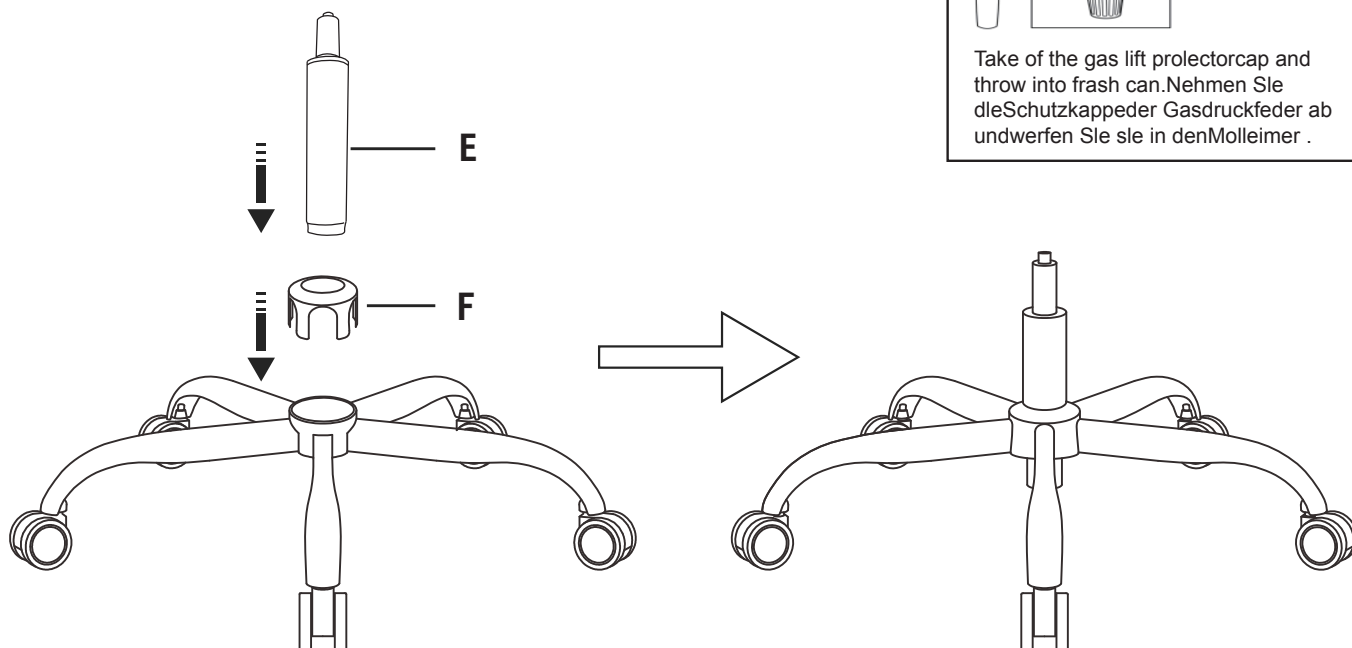

5.

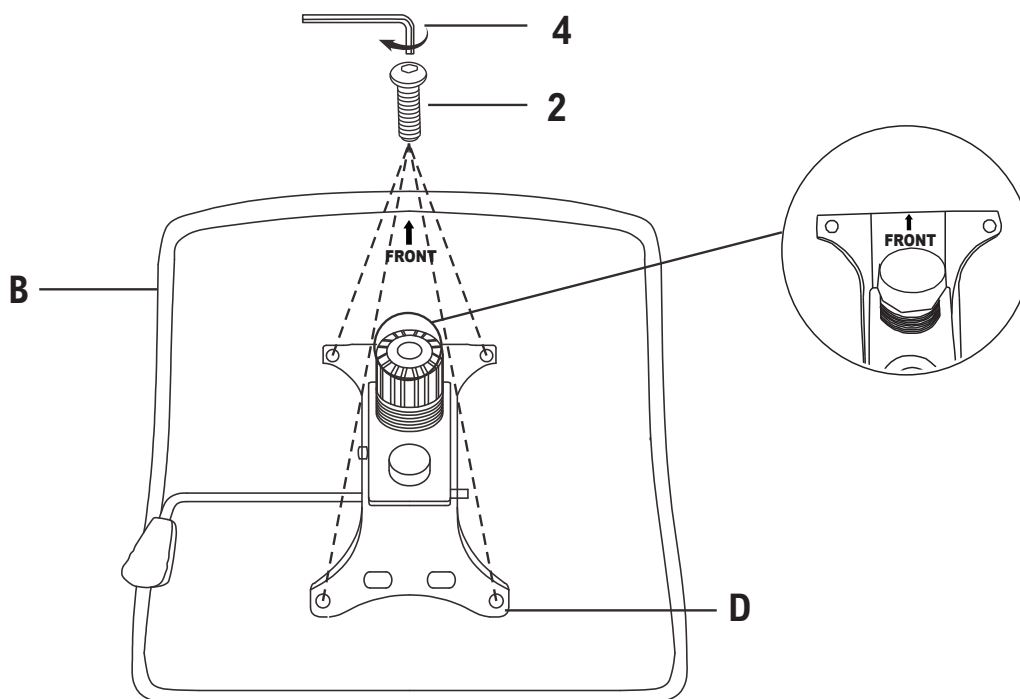

Attention: When assembling, first insert all the screws until they are about 50% tight, then tighten all screws fully to 100%

Bei der Montage setzen Sie zuerst alle Schrauben ein undziehen Sie sie bis etwa 50 % an, bevor Sie alle Schraubenvollständig auf 100 % anziehen.

6.

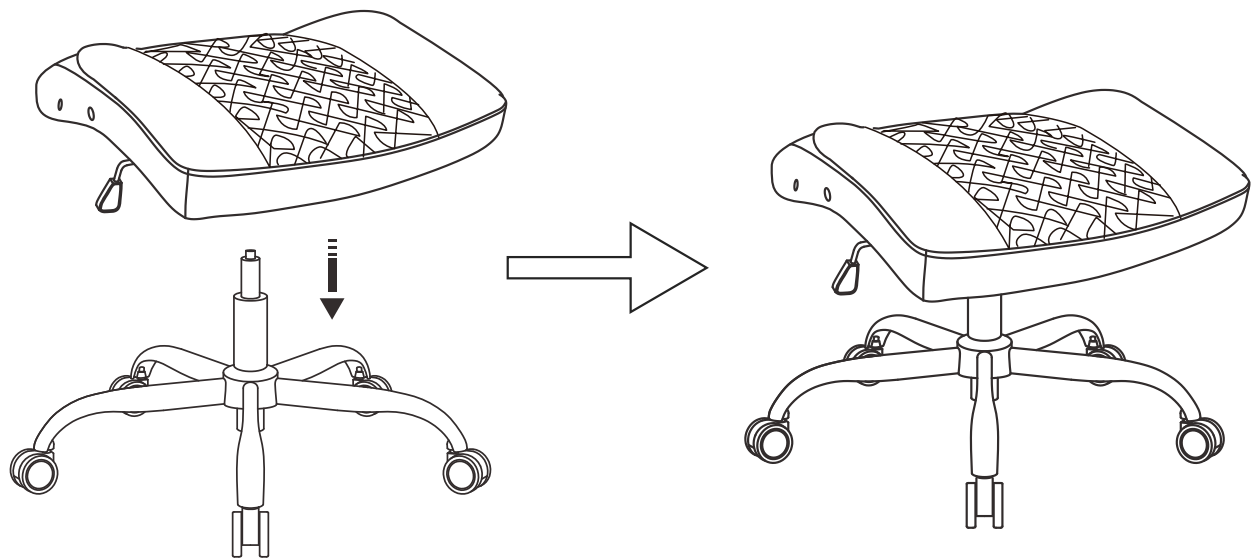

7.

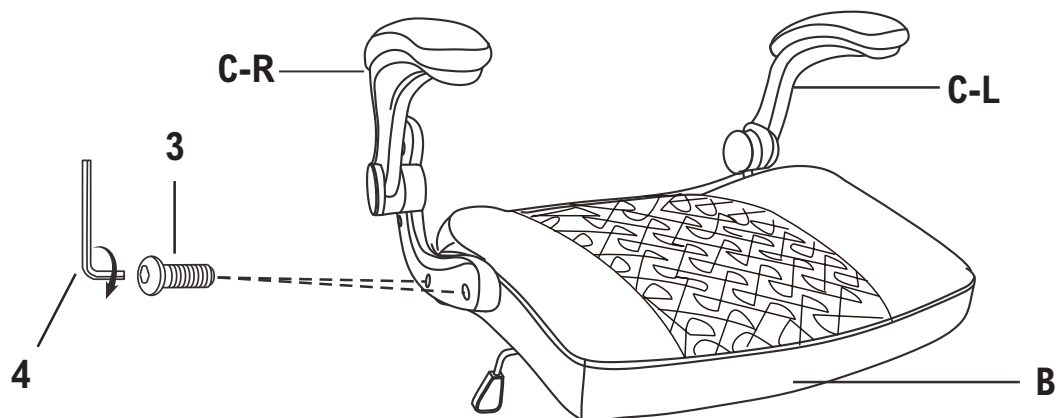

Attention: When assembling, first insert all the screws until they are about 50% tight, then tighten all screws fully to 100%

Bei der Montage setzen Sie zuerst alle Schrauben ein und ziehen Sie sie bis etwa 50 % an, bevor Sie alle Schraubenvollständig auf 100 % anziehen.

8.

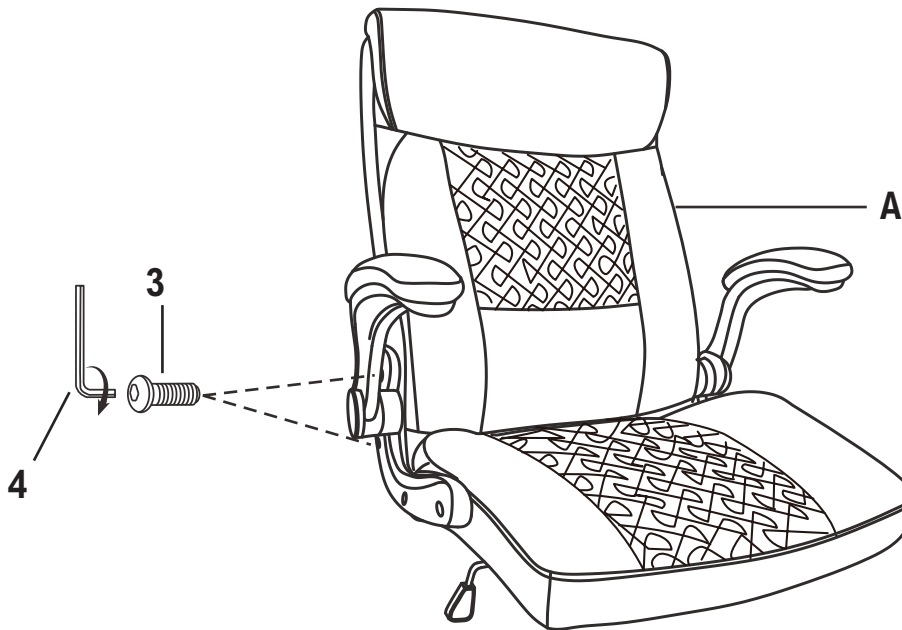

9.

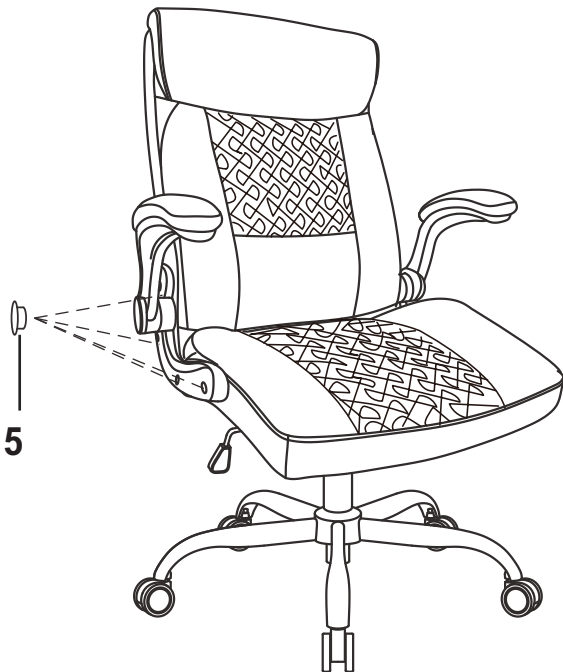

10.



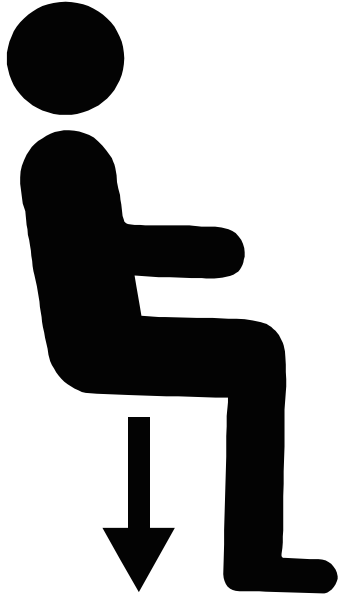

1 Load capacity up to 300 lb
Tragfähigkeit bis zu 300 lb



2 Seat Height adjustment (pull up on the control handle to adjust)
Sitzhöhenverstellung (Bedienhebel zum Einstellen nach oben ziehen)

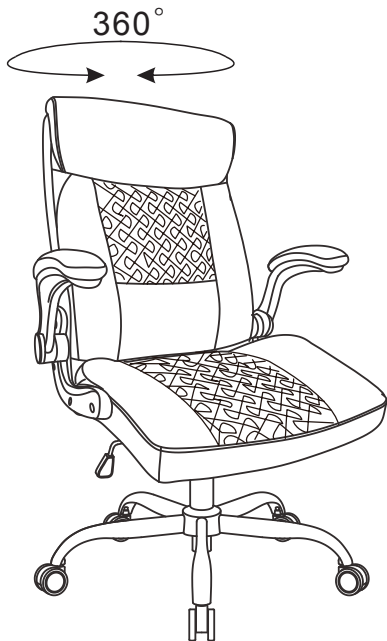

3 360 degree swivel
360-Grad-Schwenk

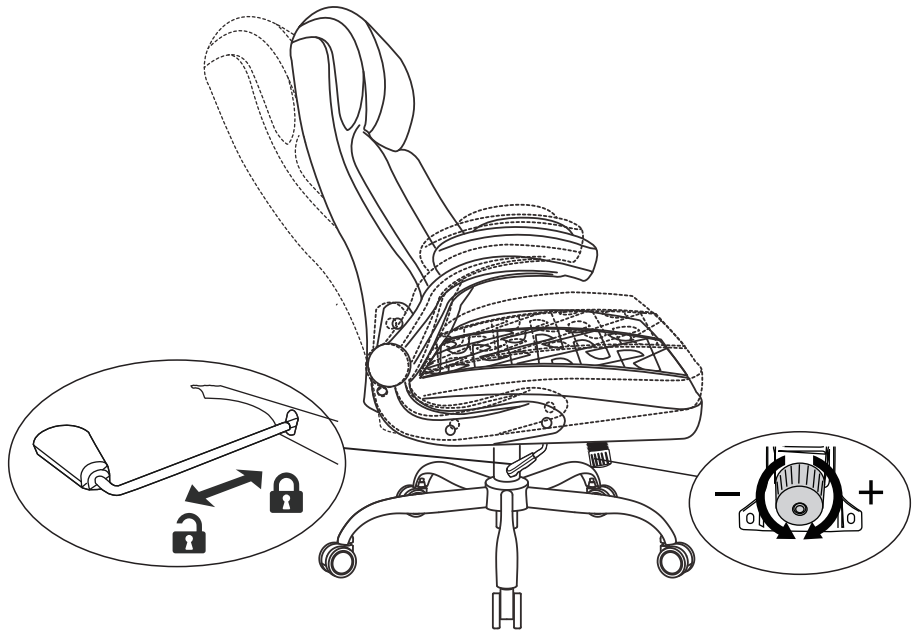

1. Move the item gently to avoid collision.
 2. Keep it away from direct sunlight.
 3. Check to ensure that the center of gravity is on the hydraulic when in use.
 4. Watch out your fingers when adjusting the backrest angle.
 5. Use the handle adjuster under the seat to adjust the seat height. Do not press or pull the seat by force.
 6. Do not place any heavy objects on the seat or armrests.
 7. Keep the plastic parts away from direct sunlight.
 8. Avoid abrasive cleaner for cleaning.
1. Bewegen Sie den Gegenstand behutsam, um Zusammenstöße zu vermeiden.
 2. Vor direkter Sonneneinstrahlung schützen.
 3. Stellen Sie sicher, dass der Schwerpunkt während der Nutzung auf dem Hydrauliksystem liegt.
 4. Achten Sie auf Ihre Finger bei der Einstellung des Rückenlehnenwinkels.
 5. Verwenden Sie den Bedienhebel unter dem Sitz zur Höhenverstellung. ****Niemals**** die Sitzfläche gewaltsam drücken oder ziehen.
 6. Keine schweren Gegenstände auf Sitzfläche oder Armlehnen abstellen.
 7. Kunststoffteile vor direkter Sonneneinstrahlung fernhalten.
 8. Reinigung mit scheuernden Mitteln vermeiden.