

660W 10-speed Stand Mixer Iron

Instruction Manual

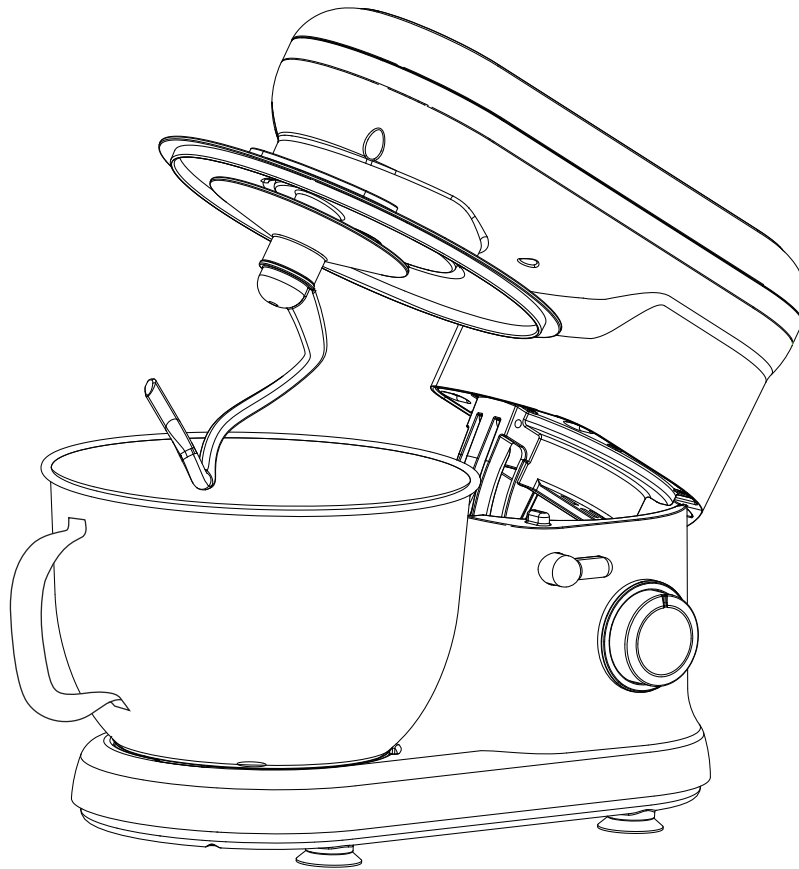

NOTE:

To continuously improve its products, VIVOHOME reserves the right to modify this information without prior notification. For any questions during assembly, please watch the video in the product page for reference. Or contact our customer service with any questions, comments, or concerns. Thank you for using VIVOHOME products in your home!

Thank You For Purchasing From
VIVOHOME
MADE IN CHINA

Technical Data

Model: SM-1519

Rated voltage: 120V, 60Hz

Power consumption: 660W

IMPORTANT SAFEGUARDS

Read the operating instructions carefully before putting the appliance into operation and keep the instructions including the warranty, the receipt and, if possible, the box with the internal packing. If you give this device to other people, please also pass on the operating instructions.

- Read all instructions.
- To protect against risk of electrical shock do not put base in water or other liquid.
- Close supervision is necessary when any appliance is used by or near children.
- Unplug from outlet when not in use, before putting on or taking off parts, and before cleaning.
- Avoid contacting moving parts.
- Do not operate any appliance with a damaged cord or plug or after the appliance malfunctions, or is dropped or damaged in any manner. Return appliance to the nearest authorized service facility for examination, repair or electrical or mechanical adjustment.
- The use of attachments not recommended or sold by the manufacturer may cause fire, electric shock or injury.
- Do not use outdoors.
- Do not let cord hang over edge of table or counter.
- Keep hands, hair, clothing, as well as spatulas and other utensils away from beaters during operation to reduce the risk of injury to persons, or damage to the mixer.
- Remove beaters from mixer before washing.
- Household use only.

SAVE THESE INSTRUCTIONS

This appliance has a polarized plug (one blade is wider than the other). To reduce the risk of electric shock, this plug will fit in a polarized outlet only one way. If the plug does not fit fully in the outlet, reverse the plug. If it still does not fit, contact a qualified electrician. Do not modify the plug in any way.

Children and Frail Individuals

- In order to ensure your children's safety, please keep all packaging (plastic bags, boxes, polystyrene etc.) out of their reach.

Caution! Do not allow small children to play with the foil as there is a **danger of suffocation!**

- In order to protect children or frail individuals from the hazards of electrical equipment, please ensure that this device is only used under supervision. This device is not a toy. Do not allow small children to play with it.

Special safety Instructions for this Machine

- Only operate this machine under supervision.
- Do not interfere with any safety switches.
- Do not insert anything into the rotating hooks while the machine is working.
- Place the machine on a smooth, flat and stable working surface.
- Do not insert the mains plug of the machine into the power socket without having installed all the necessary accessories.

Overview of the Components

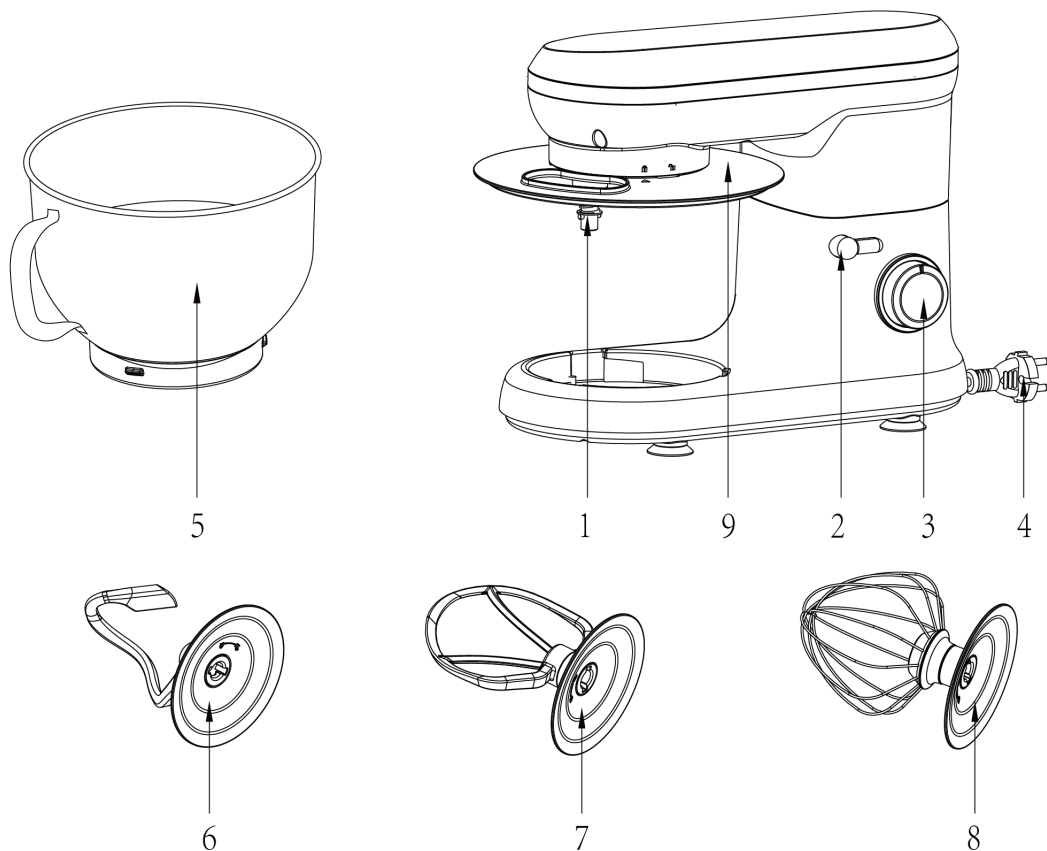

Main Components and Standard Accessories:

1	Output shaft	6	Dough hook
2	Rise button	7	Beater
3	Speed knob	8	Whisk
4	Power Cord	9	Pot cover
5	Mixing bowl		

Using the Mixing Bowl

- In order to lift the arm, press the Rise button (2) downwards in the direction of the arrow. The arm will now move upwards.(FIG1)
- Place the pot cover into its body. (FIG2)
- Place the mixing bowl into its holding device(Step①) and turn the bowl clockwise until it locks into place(Step ②). (FIG3)
- Mount the required utensil (Dough hook or Beater or Whisk) by inserting the top into the output shaft, and turn anti-clockwise until it locks into place. (FIG4&FIG5)
- Now fill in your ingredients.
Do not overfill the machine - the maximum quantity of ingredients is 1.2 Kg.
- Lower the arm using the rise button (2). (FIG6)
- Insert the mains plug into a properly installed 120V/60Hz safety power socket.

8. Switch the machine using the speed button to a speed between 1 and 10 (corresponding to the mixture).
9. For pulse operation (kneading at short intervals), turn the switch to the "PULSE" position. The switch has to be held in this position according to the desired interval length. When the switch is released it returns automatically to the "0" position.
10. After kneading/stirring turn the speed knob (3) back to the "0" position as soon as the mixture has formed a ball. Then remove the mains plug.
11. Press the rise button (2) downwards and the arm will be raised.
12. The mixture can now be released with the help of a spatula and removed from the mixing bowl.
13. The mixing bowl can now be removed.
14. Clean the parts as described under "Cleaning".



FIG1



FIG2

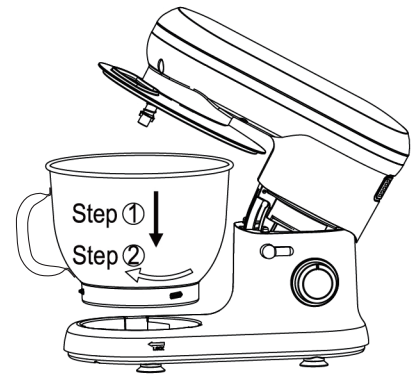

FIG3

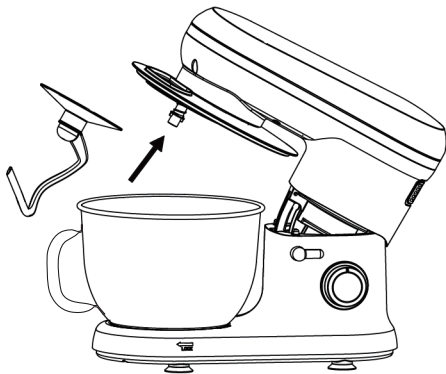

FIG4



FIG5

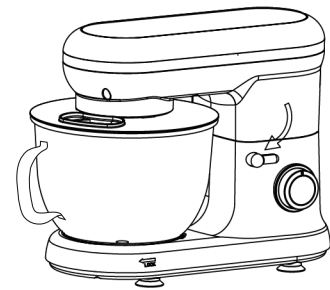
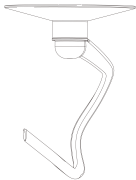
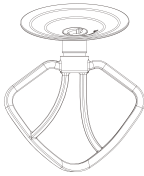



FIG6

Adjusting the Levels and Using the Hook for not more than 1.2 kg of Mixture

Use	Picture	Levels	Time(Min)	Maximum	Remarks
Dough hook		1-4	3	700g flour and 380g water	Heavy mixtures(e.g. bread or short pastry)

Beater		2-6	3	400g flour and 400~500g water	Medium-heavy mixtures(e.g.crepes or sponge mixture)
Whisk		8-10	3	3 egg whites (Minimum)	Light mixtures (e.g. cream,egg white, blancmange)

NOTE:

Short operation time: With heavy mixtures, do not operate the machine for more than six minutes, and then allow it to cool down for a further ten minutes.

Troubleshooting

NO.	Troubles	Solution
1	The machine doesn't work	<ul style="list-style-type: none"> ·Check if the plug is in good contact with the socket. ·Check if the rise button spring back in place. ·Check if the machine works continuously more than 6 minutes, and wait until the motor cool down.
2	Noise in the mixing bowl when working (the accessory scraped the bowl)	<ul style="list-style-type: none"> ·Check if the mixing bowl is properly installed. ·Check if the accessory installed properly on machine.
3	The pot cover doesn't fit the mixing bowl properly	<ul style="list-style-type: none"> ·Check if the pot cover placed on the machine properly. ·Check if the mixing bowl installed properly on machine and locked correctly.
4	The machine doesn't work on certain speed	<ul style="list-style-type: none"> ·Check if the mark on speed knob correspond to the speed silkscreen on housing. ·Rotate speed knob to 0 ,and re-check if the machine works .
5	Movements when the machine working	<ul style="list-style-type: none"> ·Check if the anti-slip feet fall off. ·Check if the machine is placed on a smooth and flat tabletop.
6	The rise button didn't spring back in place after installing the mixing bowl and pot cover	<ul style="list-style-type: none"> ·Check if the pot cover placed on the machine properly. ·Check if the mixing bowl is properly installed.

Suggested Recipes

Sponge Mixture (Basic Recipe), Level 1-6

Ingredients:

200grams soft butter or margarine, 200grams sugar, 1 packet vanilla sugar or 1 bag Citro-Back, 1 pinch of salt, 4 eggs, 400grams wheat flour, 1 packet baking powder, approx. 1/8 litre milk.

Preparation:

Transfer the wheat flour and the remaining ingredients to the mixing bowl, stir with the beater for 3 seconds on level 1, then for approximately 3 minutes on level 2. Grease a tin or cover with baking paper. Fill in the mixture and bake. Before the cake is removed from the oven, test to see if it is done. With a sharp wooden stick pierce the centre of the cake. If no mixture sticks to it, the cake is cooked. Turn the cake on to a cake grid and allow to cool.

Traditional Oven

Insertion height: 2

Heating: electric oven, top and bottom heat 175-200°Celsius; gas oven: level 2-4

Baking time: 50-60 minutes

Depending on taste, this recipe can be changed, for example with 100g raisins or 100g nuts or 100g grated chocolate. In fact, the possibilities are endless.

Linseed Bread Rolls, Level 1-6

Ingredients:

500-550g wheat flour, 50g linseed, 3/8 litre water, 1 cube of yeast (40g), 100g low-fat curds, well drained, 1 tsp salt. For coating: 2 tbsps of water.

Preparation:

Soak the linseed in 1/8 litre of lukewarm water. Transfer the remaining lukewarm water (1/4 litre) into the mixing bowl, crumble in the yeast, add the curds and mix with the dough hook on level 2. The yeast must be completely dissolved. Put the flour with the soaked linseed and the salt into the mixing bowl. Knead thoroughly on level 1, then switch to level 4 and continue kneading for 3-5 minutes. Cover the mixture and allow to rise in a warm place for 45-60 minutes. Knead thoroughly once more, remove from the bowl and form sixteen rolls. Cover the baking tin with wet baking paper. Place the rolls on this and allow to rise for 15 minutes. Coat with lukewarm water and bake.

Traditional Oven:

Insertion height: 2

Heating: electric oven: top and bottom heat 200-220°C (preheated for 5 minutes), gas oven level 2-4

Baking time: 30-40 minutes

Chocolate Cream, Level 8-10

Ingredients:

200ml sweet cream, 150g semi-bitter chocolate coating, 3 eggs, 50-60g sugar, 1 pinch of salt, 1 packet of vanilla sugar, 1 tablespoon cognac or rum, chocolate flakes.

Preparation:

Beat the cream in the mixing bowl with the whisk until stiff. Remove from the bowl and place somewhere to cool. Melt the chocolate coating in accordance with the instructions on the packet or in the microwave at 600W for 3 minutes. In the meantime, beat the eggs, sugar, vanilla sugar, cognac or rum and salt in the mixing bowl with the whisk on speed 2 to form a foam. Add the melted chocolate and stir in evenly on speed 8-10. Leave a little of the cream for decoration. Add the remaining cream to the creamy mixture and stir in briefly using the pulse function. Decorate the chocolate cream and serve well cooled.

Pizza dough, Level 1-6

Ingredients

400g plain flour, 250ml warm water, 1/2 tsp sugar, 1 sachet active dried yeast (about 2-1/2 tsp), 1-1/2 tsp olive oil and 1 tsp salt.

Preparation:

Put the flour in the bowl. Mix the remaining ingredients in a bowl or jug. Run the mixer at speed 1-2, and gradually add the liquid. As the ingredients incorporate, and the dough ball becomes more formed, increase the speed to 4-6. Knead for a couple of minutes on this speed, till the dough ball is smooth. Remove from the bowl and split into 2-6 pieces. Roll into pizza bases (circles or rectangles) on a floured surface, then lay them on a baking sheet or pizza tray. Spread the pizza bases with tomato purée and add toppings – mushrooms, ham, olives, sun dried tomatoes, spinach, artichoke, etc. Top with dried herbs, pieces of mozzarella, and a drizzle of olive oil. Bake in a preheated oven at 200°C/400°F/gas 6 for 15-20 minutes, till the toppings are bubbling and golden brown.

Basic White Bread, Level 4-10

Ingredients:

600g strong white bread flour 1 sachet active dried yeast (about 2½ tsp) 345ml warm water 1 tbsp sunflower oil or butter 1 tsp sugar 2 tsp salt

Preparation:

Use the mixing instructions for pizza dough, then put the dough in a bowl, cover and leave in a warm place till it's doubled in size (30-40 minutes). Remove the dough and punch down to remove air. Knead lightly on a floured board, shape it into a loaf, or put it in a tin, cover, and leave in a warm place to rise for another 30 minutes. Bake in a preheated oven at 200°C/400°F/gas 6 for 25-30 minutes, till golden brown and hollow sounding on the bottom.

Soft Poppy Seed Rolls, Level 1-4

Ingredients:

570g strong white bread flour 1 sachet active dried yeast (about 2½ tsp) 300ml milk (warmed slightly) 2 eggs (room temperature) 1 tbsp sunflower oil 1½ tsp sugar 2 tsp salt 75g poppy seeds

Preparation:

Mix the milk, eggs, oil, sugar, salt and yeast in a jug or bowl, and leave for 5 minutes. Put the flour and poppy seeds in the bowl, and mix at speed 1, gradually adding the liquid, then increase the speed to 2, and mix for five minutes. Remove the dough to a floured surface, cut into 8-10 pieces, roll into shape, then put on a greaseproof baking sheet. Leave in a warm place till doubled in size. Brush with a little egg or milk, and bake in a preheated oven at 220°C/425°F/gas 7 for 20-25 minutes, till golden brown and hollow sounding on the base.

Italian Herb Bread

Ingredients:

575g strong white bread flour, 1 sachet active dried yeast (about 2½ tsp), 290ml water 2 tbsp olive oil, 2 tsp sugar 2 tsp salt, 4 tbsp mixed dried herbs

Preparation:

Mix the water, oil, sugar, salt and yeast in a jug or bowl, and leave for 5 minutes. Put the flour and dried herbs in the bowl, and mix at speed 1, gradually adding the liquid, then increase the speed to 2, and mix for 5 minutes. Put the dough in a bowl, cover and leave in a warm place till doubled in size (20-30 minutes). Put on a floured surface, knead gently to knock out the air, then shape, put on a baking sheet, and leave in the warm till doubled in size. Bake in a preheated oven at 200°C/400°F/gas 6 for 25 minutes or till golden brown and hollow sounding on the bottom.

Coffee & Brandy Ice Cream, Level 8-10

Ingredients:

3 eggs 75g caster sugar, 300ml single cream 2 tbsp instant coffee powder, 300ml double cream 2½ tsp brandy.

Preparation:

Add the sugar and eggs to the bowl and process at speed 10 till smooth in texture. In a saucepan, bring the single

cream and coffee just to the boil and stir in the egg and sugar mixture. Put in a heatproof bowl over a simmering pan of water and cook gently, stirring well, till thick enough to coat the back of a spoon. Strain into a bowl and leave to cool. Whip the double cream at speed 10 till soft peaks form, then fold into the cold egg and sugar mixture, with the brandy. Pour into a container, cover, and freeze for 2½ -3 hours, till partially frozen. Remove, stir well and then freeze again, till the desired texture is achieved.

Basic Meringues, Level 8-10

Ingredients:

4 egg whites, 100g caster sugar, 100g icing sugar Combine

Preparation:

Put the egg whites in the bowl and process at speed 10 till fairly stiff. Add half the sugar and whisk again till the mixture is smooth, and stiff peaks have formed. Remove the bowl, and lightly fold in the remaining sugar with a metal spoon. Line a baking sheet and spoon or pipe the meringue mixture into ovals. Sprinkle with the remaining sugar A and put on the lowest shelf of a cool oven (120°C/250°F/ gas ½) for 1½ hours. Cool on a wire rack. Top with soft fruits, chocolate, and sweetened cream.

Cleaning

- Before cleaning remove the mains lead from the socket.
- Never immerse the housing with motor in water!
- Do not use any sharp or abrasive detergents.

Motor Housing

- Only a damp rinsing cloth should be used to clean the outside of the housing.

Mixing Bowl, Mixing Equipment

CAUTION:

- **The components are not suitable for cleaning in a dishwasher. If exposed to heat or caustic cleaners they might become misshapen or discolored.**
- Components that have come into contact with food can be cleaned in soapy water.
- Allow the parts to dry thoroughly before reassembling the device.
- Please apply a small quantity of vegetable oil likely to the screens after they have dried.
- Any other servicing should be performed by an authorized service representative.

Disposal



Do not dispose of the device in normal domestic waste.

Dispose of the device over a registered waste disposal firm or through your communal waste disposal facility.

Observe the currently valid regulations. In case of doubt, consult your waste disposal facility.