



ADVANCED SERIES

Evolution Plus 1000 EC

Category Benefits

This model offers the following benefits:

- Food waste is ground into particles and flushed away
- A convenient solution to food waste in the home
- Lift & Latch Technology and rubber grips on trim shell make it easy to install into new or existing kitchens and can be fitted to most sinks

Features

This model offers the following features:

- **1 HP induction motor** provides maximum grinding power and durability
- **Quietest SoundSeal Technology** is our quietest disposal on the market
- **Advanced Grind** for tough and fibrous food scraps
- **4-Stage MultiGrind Technology.** Finest grind (Compared to 1- and 2-Stage MultiGrind Technology)
- **Vented removable baffle**
- Safe for use with properly maintained septic tanks
- Air Switch in Chrome

Warranty

Up to 5-Year Limited Warranty*

* Visit www.insinkerator.com/product-registration for warranty details.

Specifications

Type of Feed	Continuous
On/Off Control	Air Switch
Motor	Single Phase
Motor HP	1
Volts	220-240
HZ	50-60
Motor Power, W	450W
Time Rating	Intermittent
Lubrication	Permanently Lubricated Upper & Lower Bearings
Shipping Weight (Approx.)	9.16 kg
Overall Height	31.2 cm
Motor Protection	Automatic Reset
Drain Connection	3.8 cm Anti-Vibration (Hose Clamp)
Dishwasher Drain Connection	Yes
Grind Technology	4-Stage MultiGrind Technology
Plug	3pin UK
Grind Chamber Capacity	980 ml

Dimensions

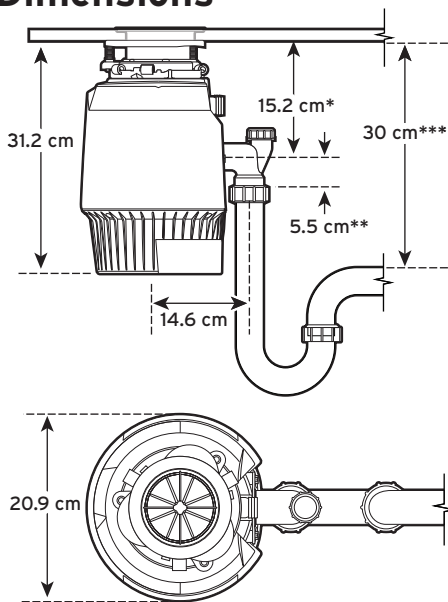

*Distance from bottom of sink to centre line of disposer outlet. Add 12.7 mm when stainless steel sinks are used.

**Length of tailpipe from centre line of disposer outlet to end of tailpipe.

***Distance between bottom of sink bowl to the waste pipe to be minimum of 30 cm.