

Assembly Instructions

Case & Maintenance



Not for commercial use. For residential use only.



Furniture may scratch floors. We recommend using furniture pads to protect your floors.



Do not put hot items directly on furniture surface.



Do not clean furniture with harsh cleansers or polish.



Do not place furniture under direct sunlight.



Do not write on furniture near heating or cooling vents.



Do not write on furniture without a padded barrier to protect the surface.



Do not place furniture outside for indoor use only



Stains may be removed with mild soap solution and damp cloth.



Children should not climb or jump on the furniture.



Dust and pick-upspills using a clean, non-colored, lint-free cloth.



Please look in the box for hardware packs and legs.

Sets oftenship in multiple boxes and may arrive a day or two apart.

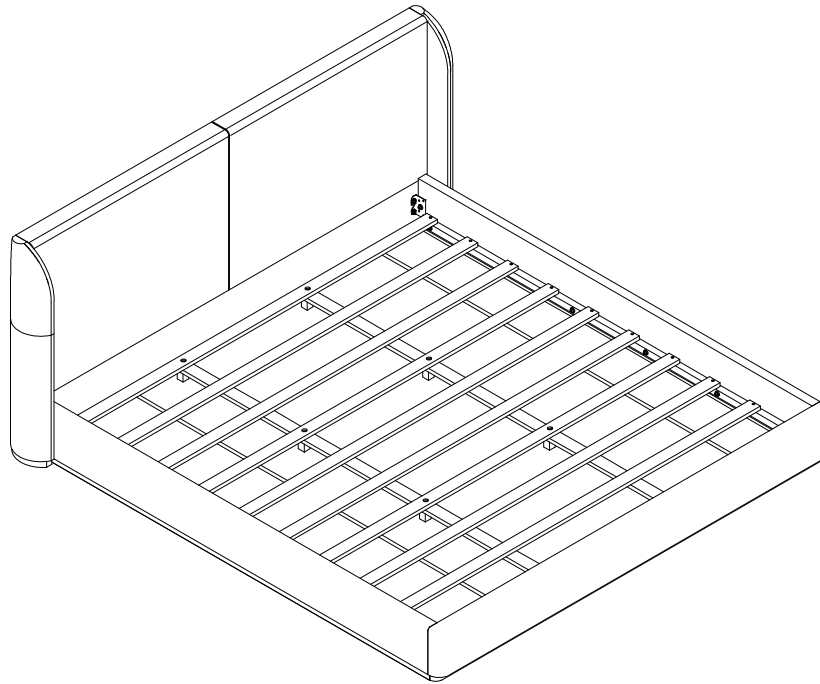
King Bed

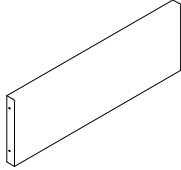
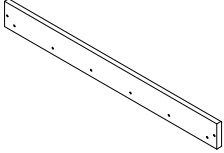
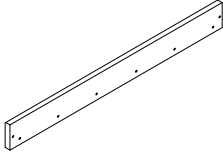
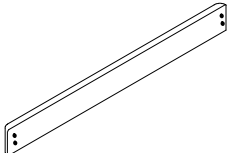

Part List

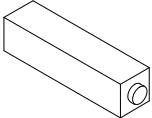
Label	Picture	Description	QTY
①		Headboard	1
②		Side Rail (R)	1
③		Side Rail (L)	1
④		Footboard	1
⑤		Headboard Leg	2
⑨		Center Support Leg	8



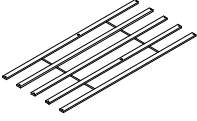
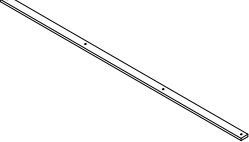
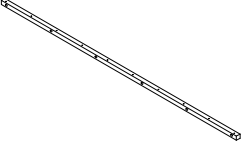
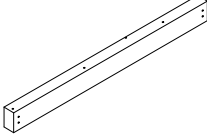
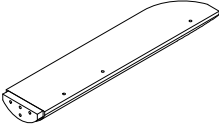
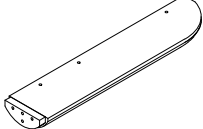

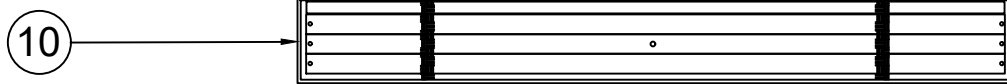



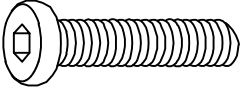
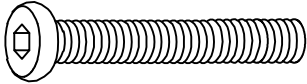

Part List

Label	Picture	Description	QTY
⑥		Slats	2
⑦		Middle Support Bar	2
⑧		Support Rail	2
⑩		Headboard Storage	1
⑪		Headboard Wing (R)	1
⑫		Headboard Wing (L)	1



Noted : Slats (6) are packaged behind the Headboard Storage (10).

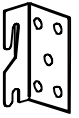





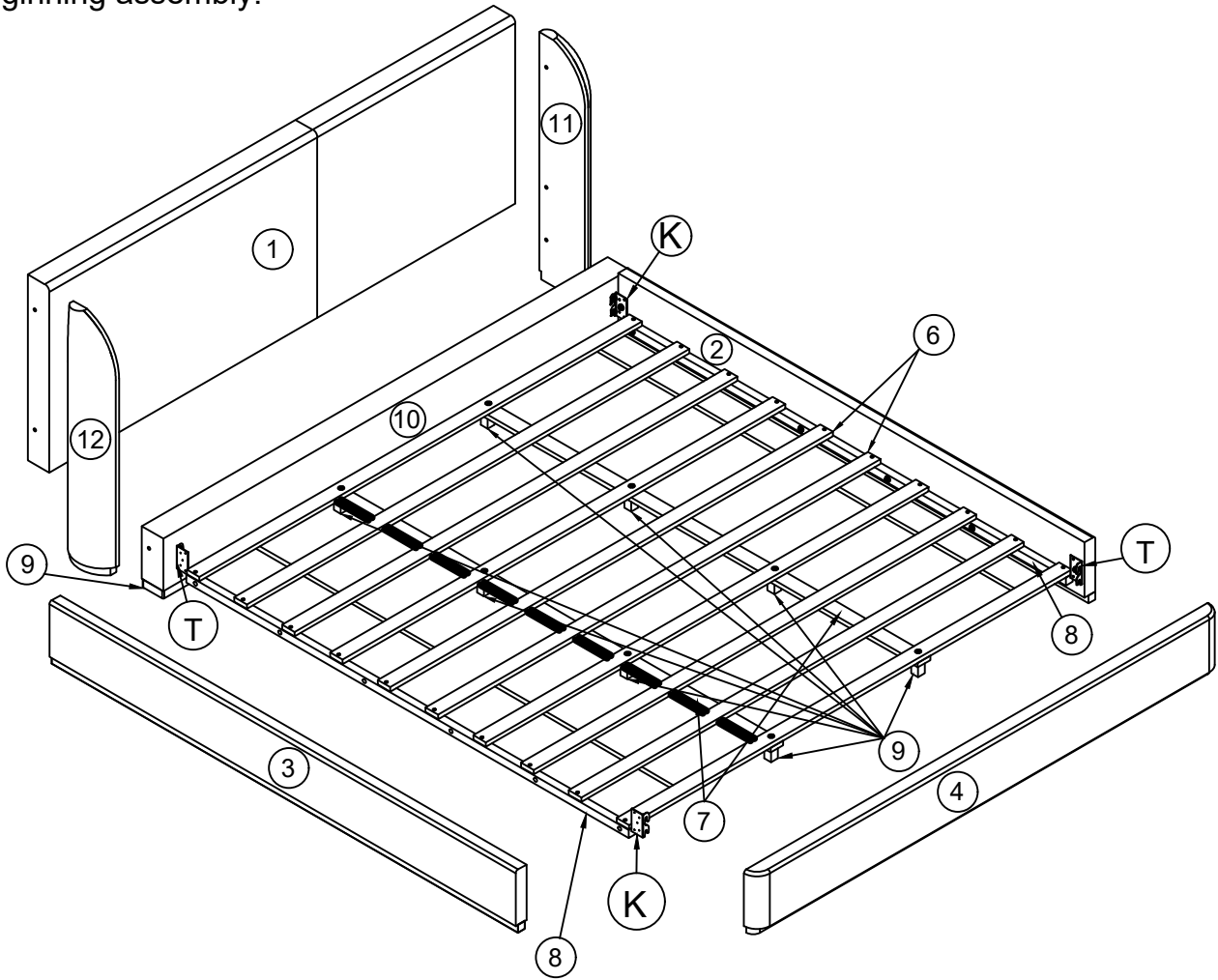

Hardware





Label	Picture	Description	QTY
(A1)		Screw(4x30mm)	36+1
(A2)		Screw(4x40mm)	10+1
(B)		Bolts(5/16"x30mm)	12+1
(C)		Bolts(5/16"x50mm)	22+1
(D)		Bolts(1/4"x50mm)	8+1
(E)		Lock washer(5/16")	34+1
(F)		Flat washer(5/16")	34+1
(G)		Lock washer(1/4")	8+1
(H)		Flat washer(1/4")	8+1
(T)		Metal pad(L)	2
(K)		Metal pad(R)	2
(M)		Allen Wrench(M4)	1+1

Assembly Preparation

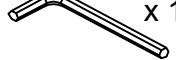
Before Beginning assembly:



A1  x 36pcs+1	C  x 22pcs+1	E  x 34pcs+1	G  x 8pcs+1
A2  x 10pcs+1	D  x 8pcs+1	F  x 34pcs+1	H  x 8pcs+1
B  x 12pcs+1			M  x 1pcs+1

-  Read the instructions cover to cover
-  Have 2 adults on hand for assembly
-  Do not assemble on flooring or carpet
-  Assemble on a clean, non-marring surface (packing foam)
-  Save all packaging until finished

Assembly Steps

OVERVIEW

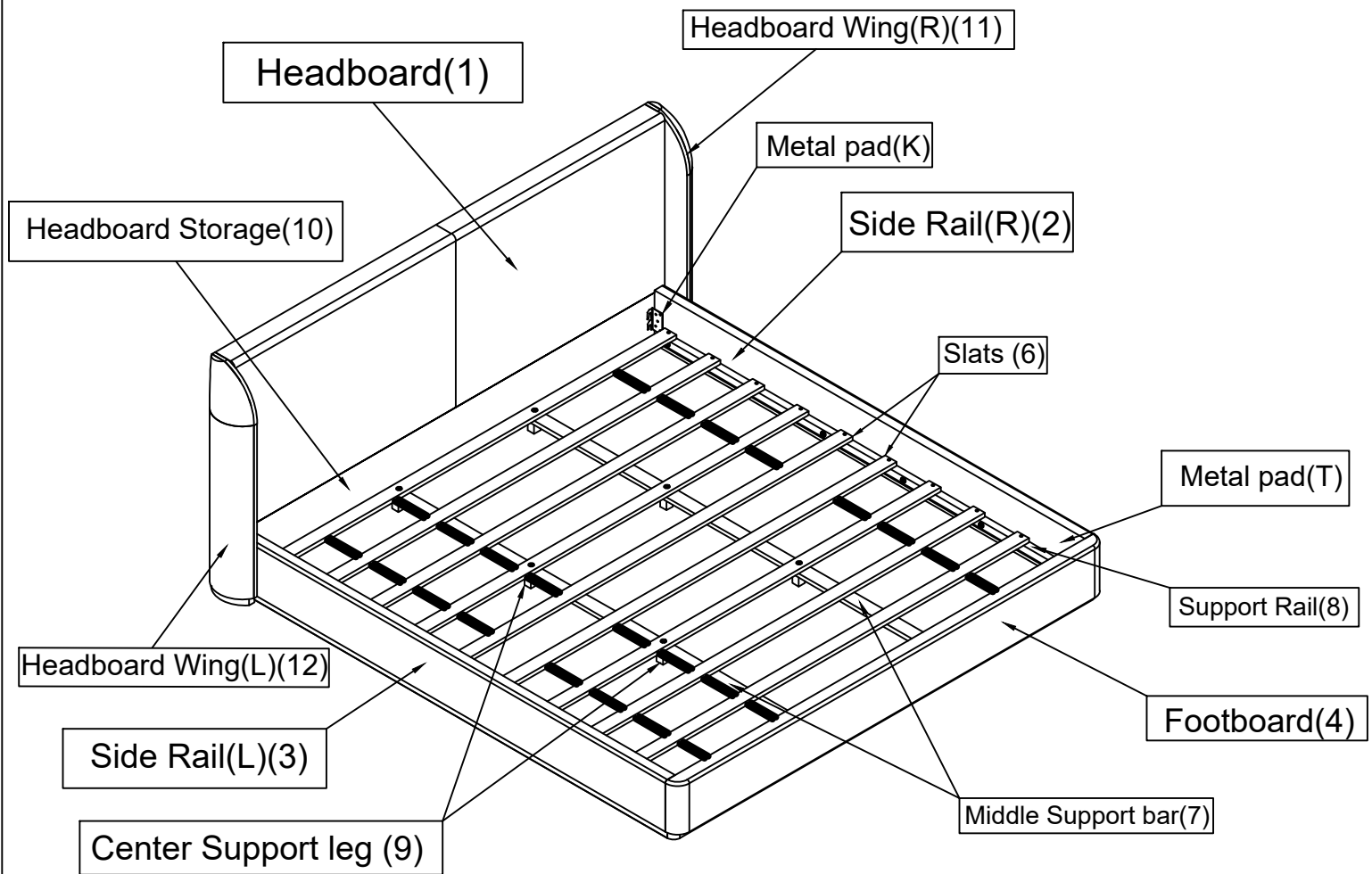





FRONT FACING

This Bed have multiple parts and may require up to 30 minutes to assemble. To give you an overview of the Bed parts, the above picture is to help you put the various parts into perspective. Please read through the instructions below to familiarise yourself with the parts and steps before assembly.

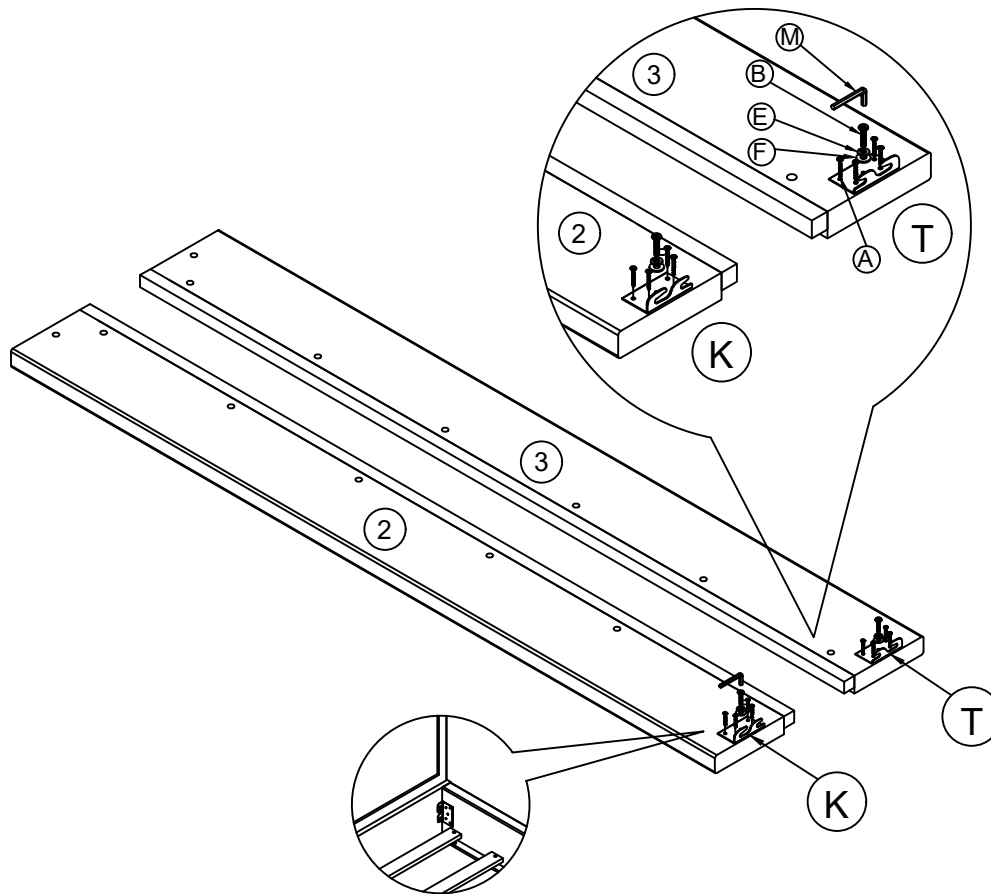
Note: It is recommended that you have an adult partner to assist during the entire assembly process.

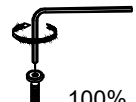
Step 1



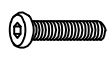

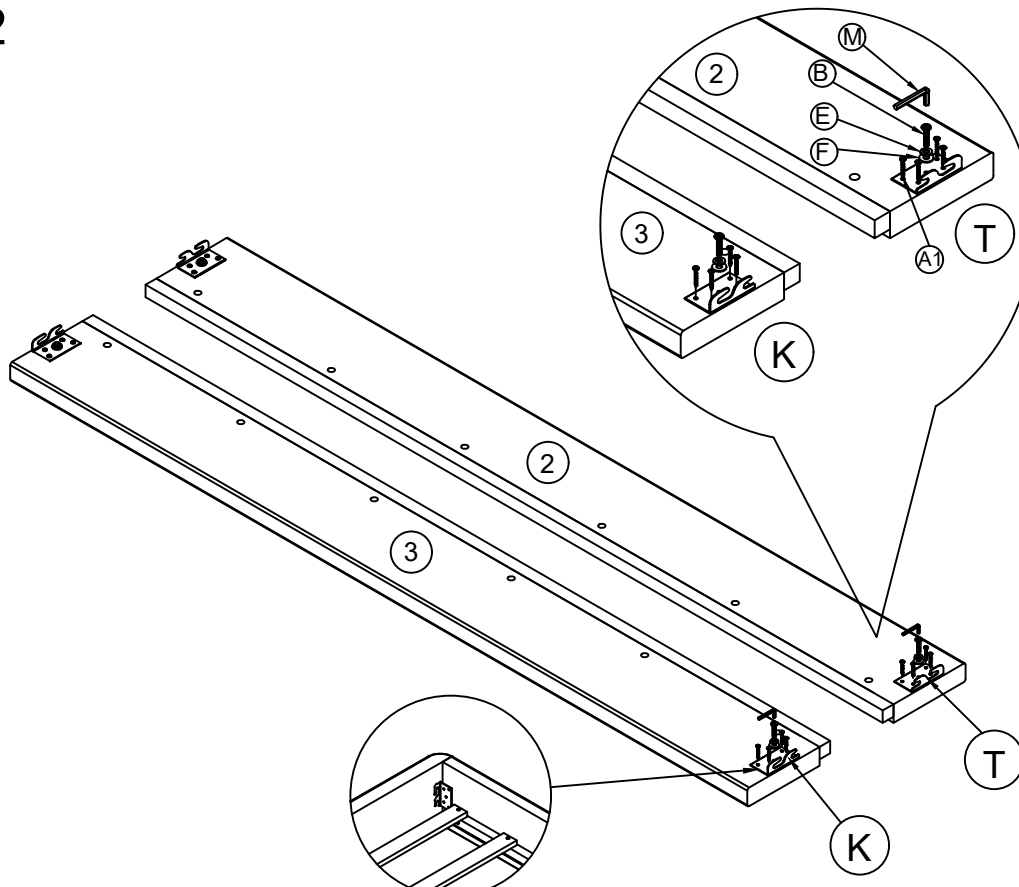

- M**  M4 100%
- A1**  4x30mm x8pcs
- E**  5/16" x2pcs
- F**  5/16" x2pcs
- M**  M4
- B**  5/16"x30mm x2pcs

Attach the Metal pad (K) to the Side Rail(R) (2), attach the Metal pad (T) to the Side Rail(L) (3).
 By using the Screw (A1) and the Bolts (B) with M4 Allen Wrench (M) to connect the Metal pad and the Side Rail
 (Note :The direction of the Metal pad and this place is connected to the Headboard Storage (10).

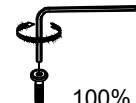
Step 2



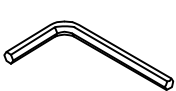
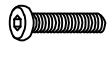

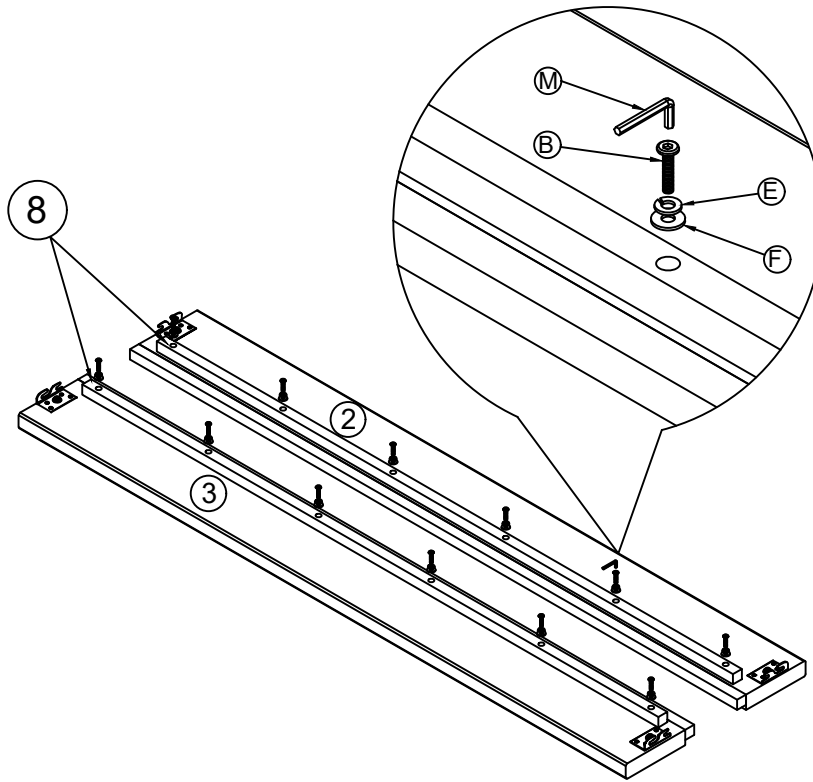

- M**  M4 100%
- A1**  4x30mm x8pcs
- E**  5/16" x2pcs
- F**  5/16" x2pcs
- M**  M4
- B**  5/16"x30mm x2pcs

Attach the Metal pad (T) to the Side Rail (2), attach the Metal pad (K) to the Side Rail (3).
 By using the Screw (A1) and the Bolts (B) with M4 Allen Wrench (M) to connect the Metal pad and the Side Rail
 (Note :The direction of the Metal pad and this place is connected to the Footboard (4).

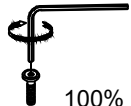
Step 3





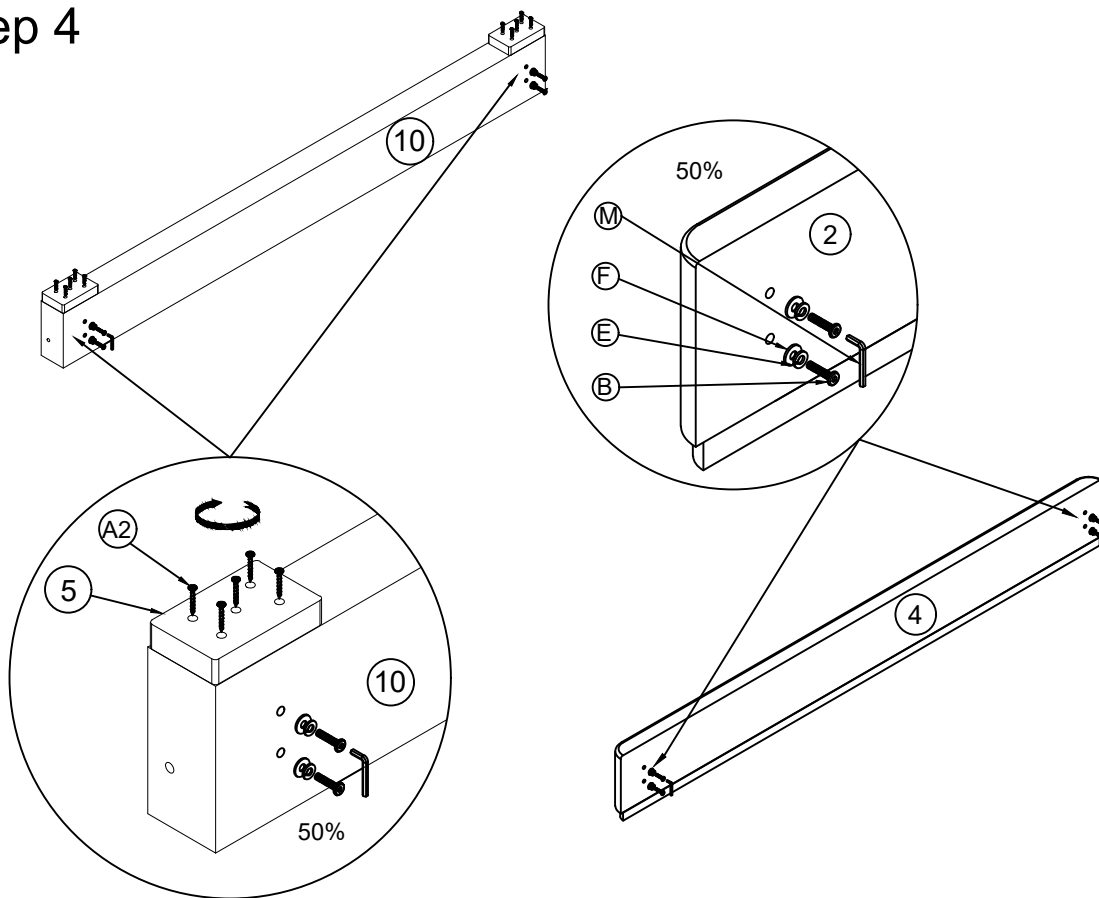

- M  100%
- M4
- E  x12pcs
- 5/16"
- F  x12pcs
- 5/16"
- M  M4
- C  5/16"x50mm x12pcs

Attach the Support Rail (8) to the Side Rail (2) and the Side Rail (3). By using the Bolts (C), the Flat Washer(F) and the Lock Washer(E) with M4 Allen Wrench(M)

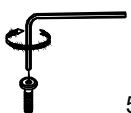
Step 4



- A2  4x40mm x10pcs
- M  M4 50%
- E  x8pcs
- 5/16"
- F  x8pcs
- 5/16"
- M  M4
- B  5/16"x30mm x8pcs

Use Bolts (B) and Lock Washer (E) with Flat Washer (F). Then attach 1/2 Bolts (B) to the Headboard Storage(10) and Footboard (4)
 Use 10 Screws (A2) to fix shot the 2 Headboard Legs(5) into the Headboard Storage(10)

Step 5

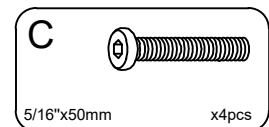
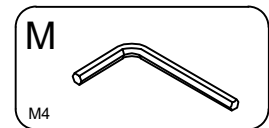
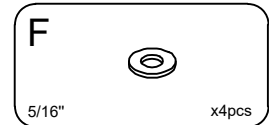
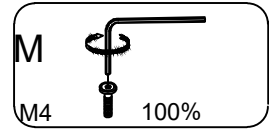
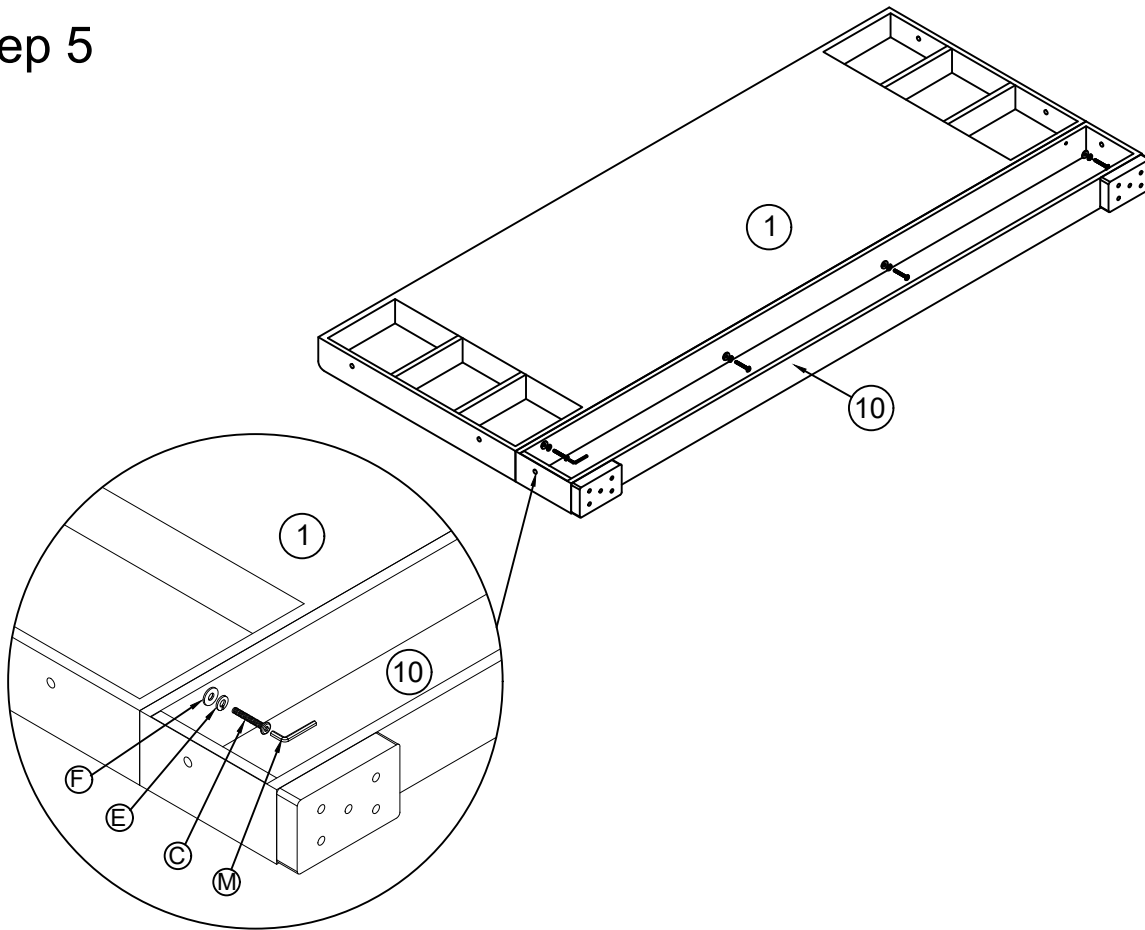

Use the Bolts (C), Lock washer (E) and Flat washer (F) to connect the Headboard (1) and the Headboard Storage (10) then tighten with Allen Wrench (M).

Step 6

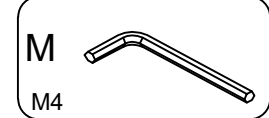
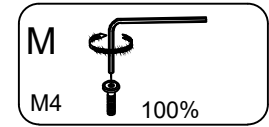
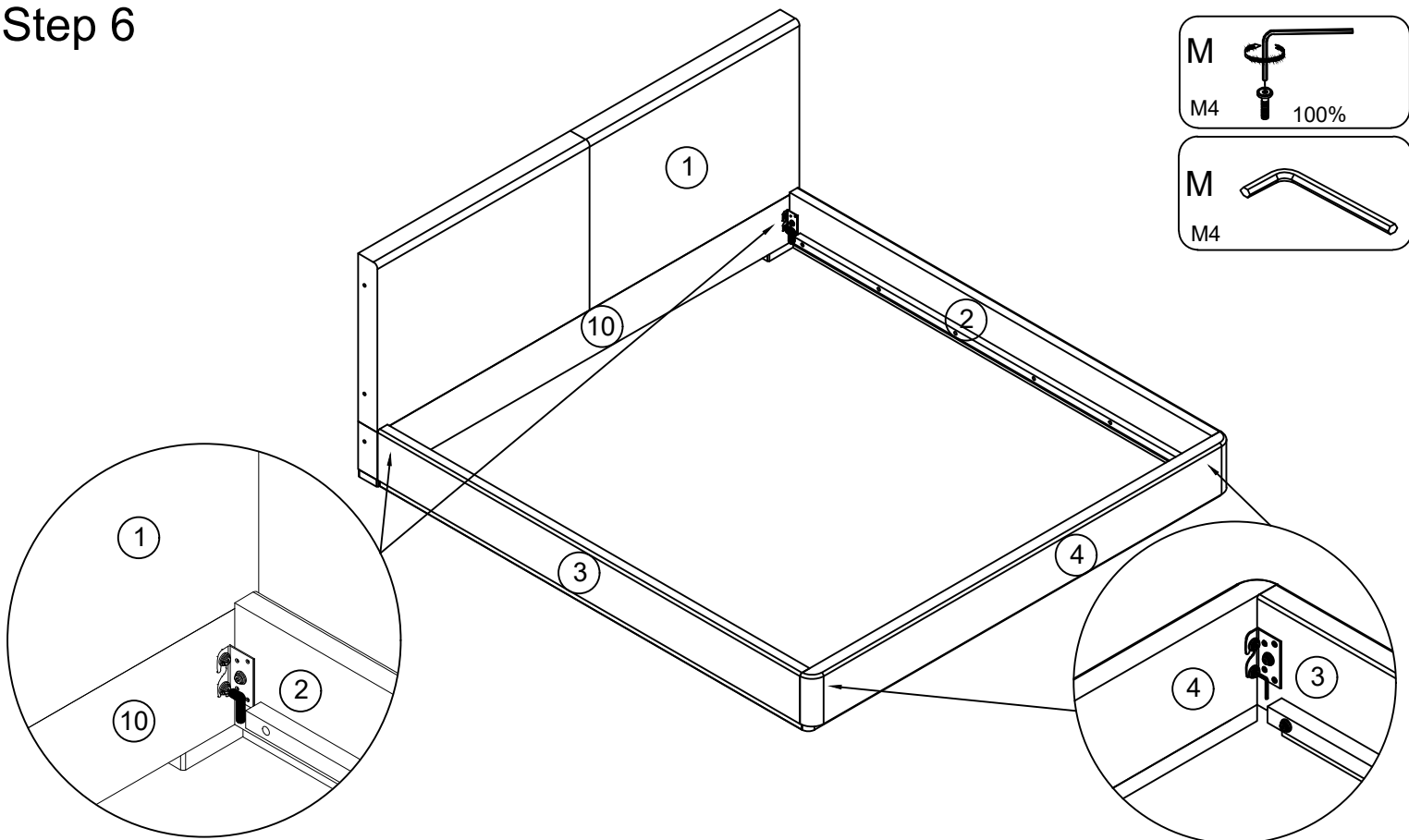

Attach the Side Rail(R)(2) and the Side Rail(L)(3) to the Headboard Storage (10) (Note: the direction of the Metal pad is down), by using M4 Allen Wrench (M) to tighten the Bolts (B). Then attach the Footboard (4) to the Side Rail(R)(2) and the Side Rail(L) (3). (Note: the direction of the Metal pad is down), by using M4 Allen Wrench (M) to tighten the Bolts (B).

Step 7

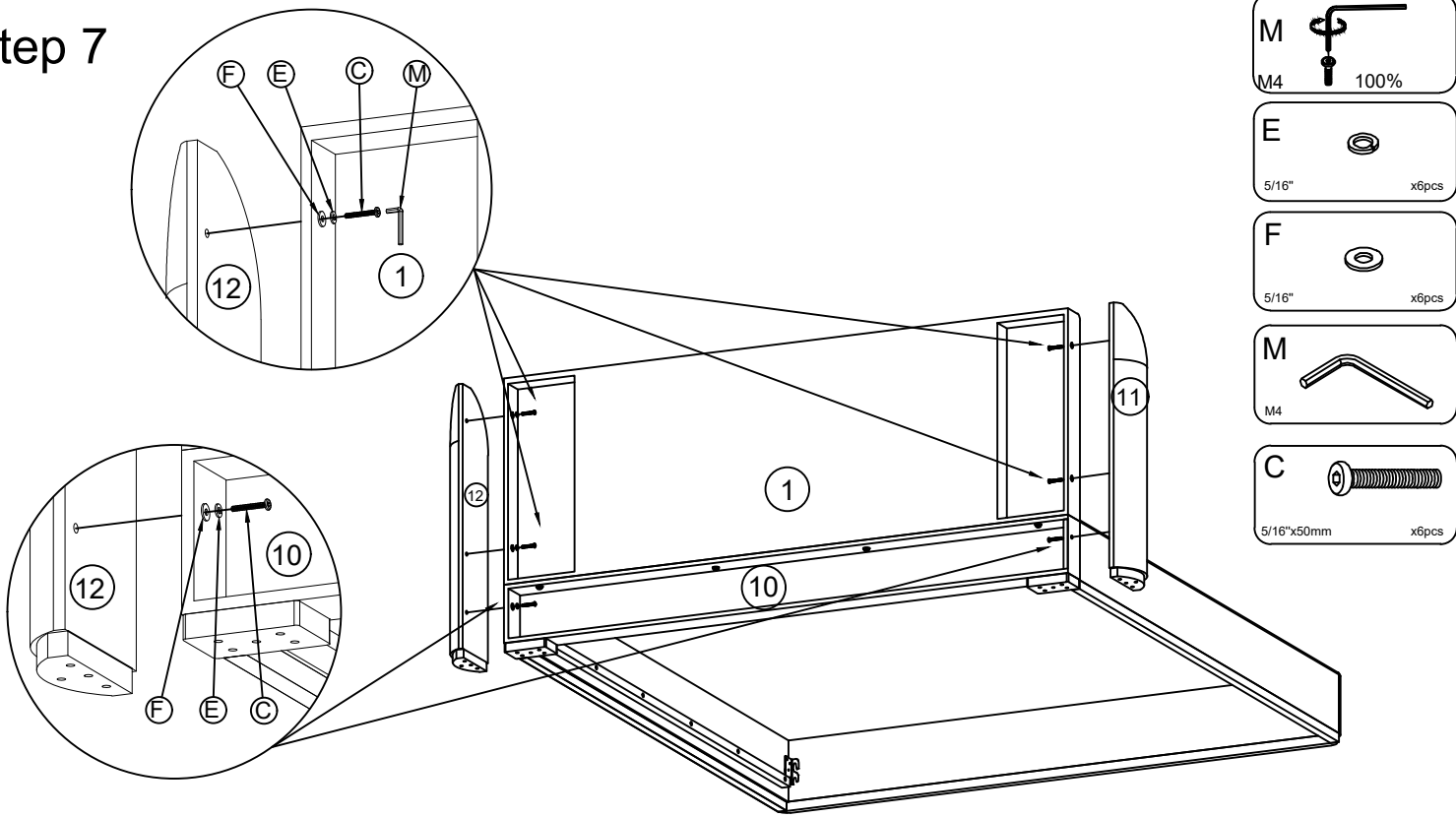

Use the Bolts (C), Lock washer (E) and Flat washer (F) to connect the Headboard Wing (R)(11) and Headboard Wing (L)(12) into Headboard(1) then tighten with Allen Wrench (M). Use the Bolts (C), Lock Washer (E) and Flat Washer (F) to connect the Headboard Wing (R)(11) and Headboard Wing (L)(12) into Headboard Storage(10) then tighten with Allen Wrench (M).

Step 8

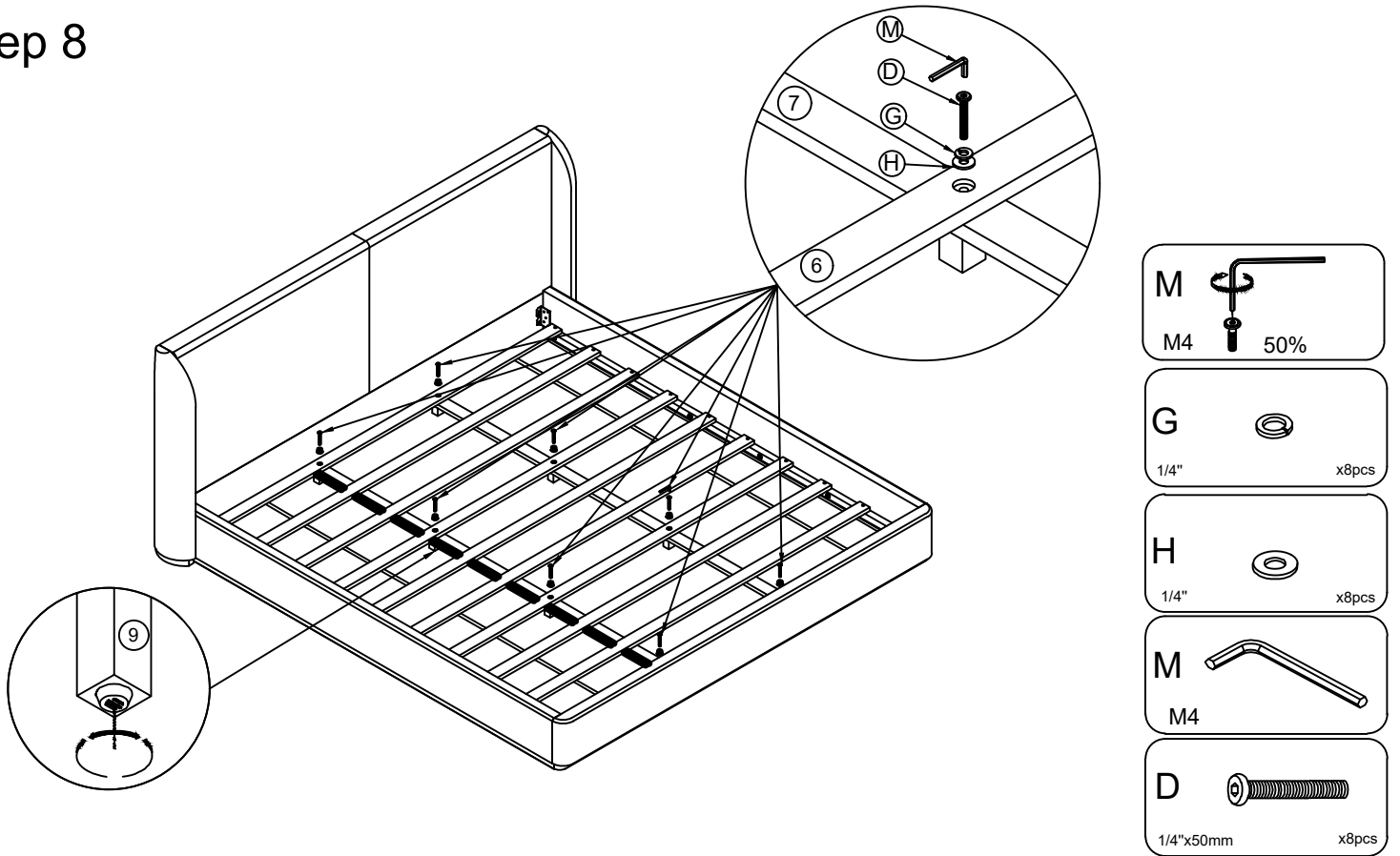

Align the assembly position on the Middle Support Bar (7) with the Center Support Leg (9) and the Slats (6). Then attach the Slats (6) and the Middle Support Bar (7) to the Center Support Leg (9). By using the Bolts (D), Lock Washer (G) with Flat Washer (H) with M4 Allen Wrench (M).

Step 9

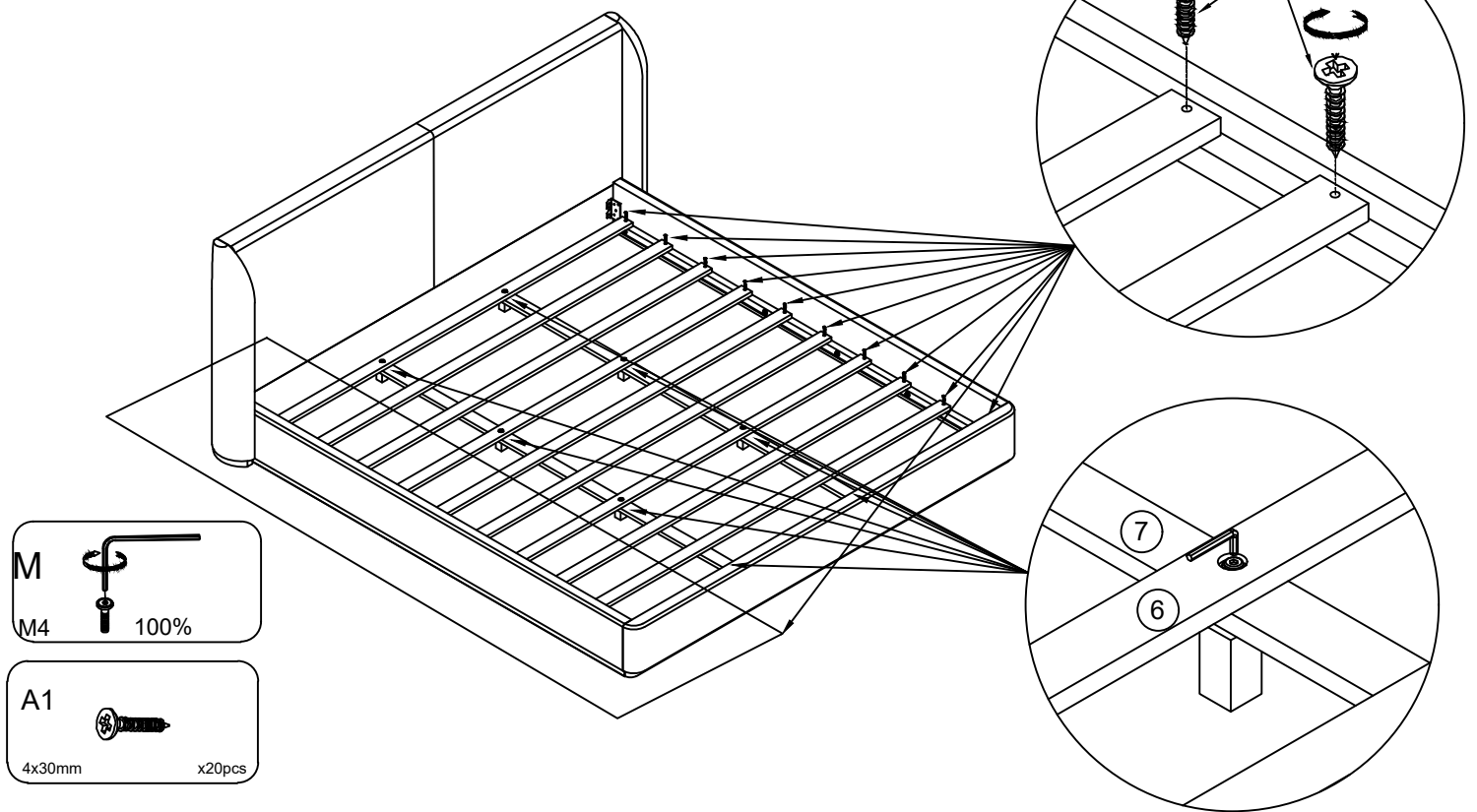

Assemble the Slats (6) to the bed Sides Rail (2) and (3). Use Screw (A1)
Finally, use the M4 Allen Wrench (M) to tighten the Bolts (D) 100%. Adjustable leveling foot of Center Support Legs (9).

Finish

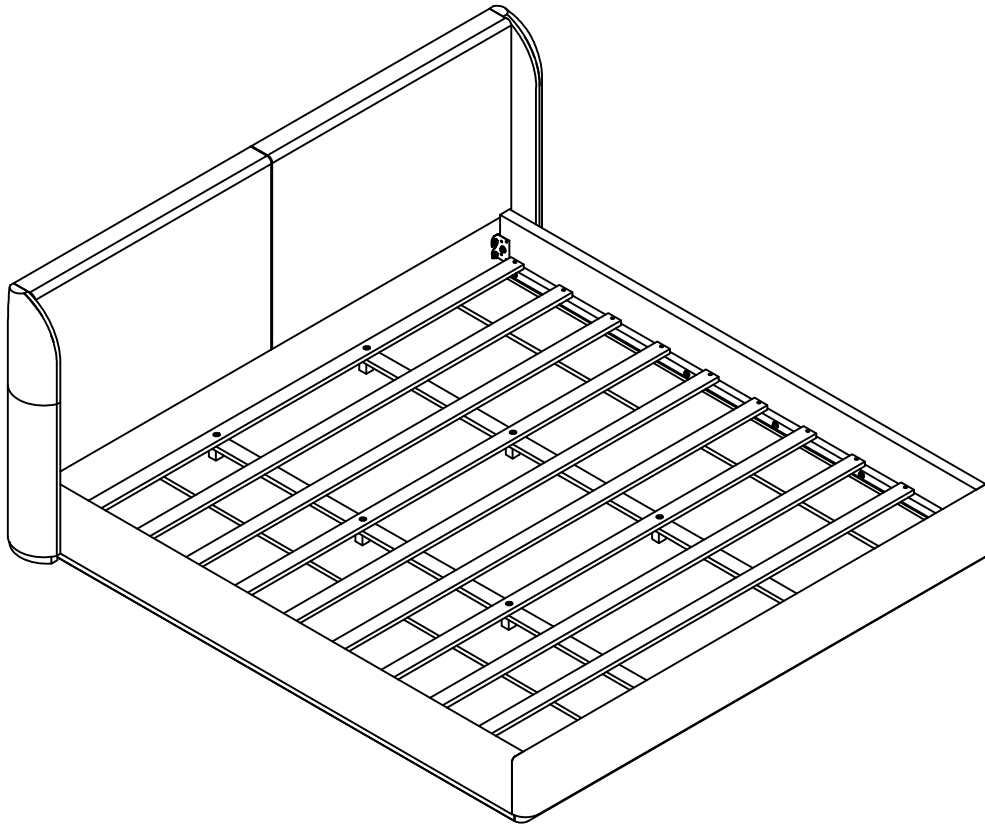

Thank you for your trust and preference in using our products.
The product will bring you a peaceful sleep forever

Finish

Place the Bed on a LEVEL SURFACE.

Inspect it and make sure all parts are adequately connected.

Don't push too hard,shake on the bed.

This would help to align all the parts at the joint areas.

CAUTION 1: When tightening these screws, tighten sequentially.

DO NOT tighten any screws fully and the towards the next one.

This would cause the frame to warp.

If there is still wobbles, loosen the screws and execute this same process.DO NOT tighten any screws fully and then towards the next one.

WARNING!! IF BED IS NOT STABLE, IT COULD LEAD TO DAMAGING THE PRODUCT.

Ensure all screws are fully locked into position.

The bed is ready to be used.

Caution 2: This bed can only be used on a flat,level surface.