

USE AND CARE GUIDE

52-INCH CEILING FAN

SIZE: 52"D x 14"-19 "-24"H

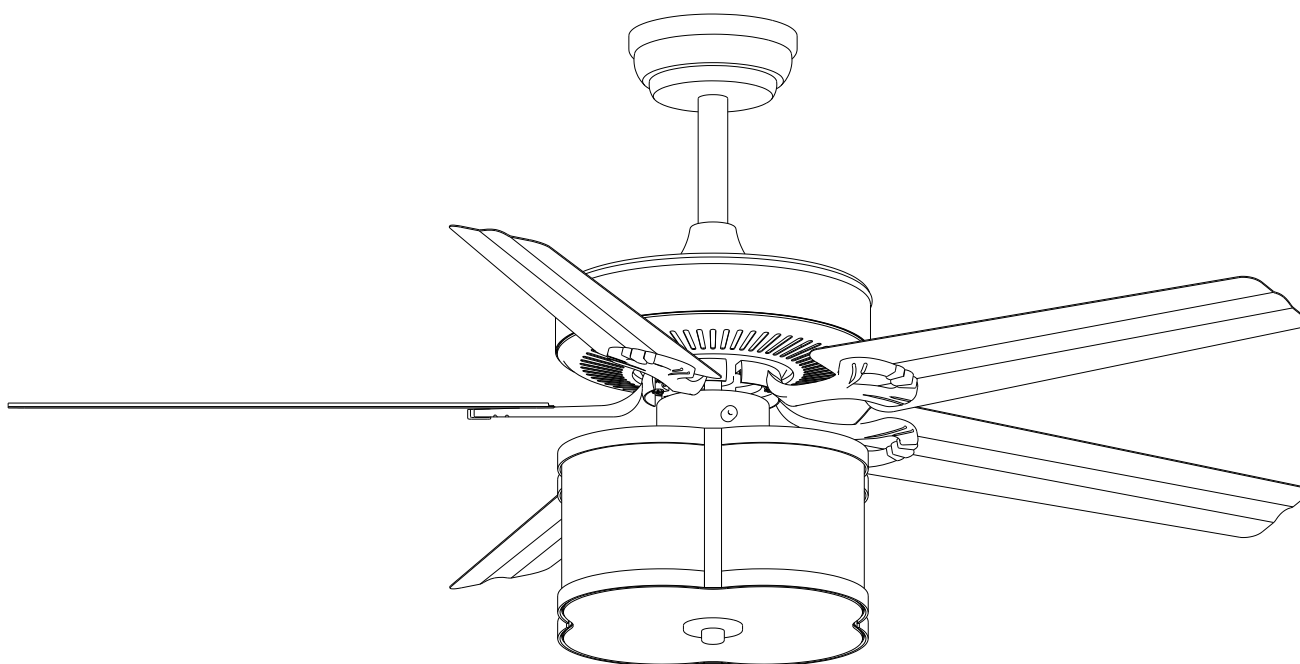

Table of Contents

Table of Contents - - - - -	2	Option 1-2 - - - - -	9
Safety Information - - - - -	2	Assembly - - - - -	11
Warranty - - - - -	3	Use of remote control - - - - -	15
Pre-Installation - - - - -	3	Care and cleaning - - - - -	16
Assembly - - - - -	8	Troubleshooting - - - - -	16

Safety Information

READ AND SAVE THESE INSTRUCTIONS

1. To reduce the risk of electric shock, ensure the electricity has been turned off at the circuit breaker or fuse box before you begin.
2. All wiring must be in accordance with the National Electrical Code ANSI/NFPA 70-1999 and local electrical codes. Electrical installation should be performed by a qualified licensed electrician.
3. The outlet box and support structure must be securely mounted and capable of reliably supporting 35 lbs (15.9 kg). Use only UL Listed outlet boxes marked "Acceptable for Fan Support of 35 lbs (15.9 kg) or less."
4. CAUTION: The fan must be mounted with a minimum of 7 ft. (2.1 m) clearance from the trailing edge of the blades to the floor.
5. Do not operate the reversing switch while the fan blades are in motion. You must turn the fan off and stop the blades before you reverse the blade direction.
6. Do not place objects in the path of the blades.
7. To avoid personal injury or damage to the fan and other items, use caution when working around or cleaning the fan.
8. Electrical diagrams are for reference only. Light kits that are not packed with the fan must be UL-listed and marked suitable for use with the model fan you are installing. Switches must be UL General Use Switches. Refer to the instructions packaged with the light kits and switches for proper assembly.
9. After making electrical connections, spliced conductors should be turned upward and pushed carefully up into the outlet box. The wires should be spread apart with the grounded conductor and the equipment-grounding conductor on one side of the outlet box.
10. All setscrews must be checked and retightened where necessary before installation.



WARNING: To reduce the risk of personal injury, do not bend the blade brackets (also referred to as flanges) during assembly or after installation. Do not insert objects in the path of the blades.



WARNING: To reduce the risk of fire or electric shock, this fan must be installed with an isolating wall switch.



WARNING: To avoid possible electrical shock, turn the electricity off at the main fuse box before wiring. If you feel you do not have enough electrical wiring knowledge or experience, contact a licensed electrician.



WARNING: Electrical diagrams are for reference only. Optional use of any light kit shall be UL-listed and marked suitable for use with this fan.



WARNING: To reduce the risk of fire, electric shock, or personal injury, mount to outlet box marked "Acceptable for fan support of 35 lbs. (15.9 kg) or less," and use the screws provided with the outlet box.



WARNING: To reduce the risk of electrical shock or fire, do not use this fan with any solid-state fan speed control device. It will permanently damage the electronic circuitry.



CAUTION: To reduce the risk of personal injury, use only the screws provided with the outlet box.

Warranty

We warrants the fan motor to be free from defects in workmanship and material present at time of shipment from the factory for a lifetime after the date of purchase by the original purchaser. The supplier also warrants that all other fan parts, excluding any glass or acrylic blades, to be free from defects in workmanship and material at the time of shipment from the factory for a period of one year after the date of purchase by the original purchaser. We agree to correct such defects without charge or at our option replace with a comparable or superior model if the product is returned. To obtain warranty service, you must present a copy of the receipt as proof of purchase. All costs of removing and reinstalling the product are your responsibility. Damage to any part such as by accident or misuse or improper installation or by affixing any accessories, is not covered by this warranty. Because of varying climatic conditions this warranty does not cover any changes in brass finish, including rusting, pitting, corroding, tarnishing, or peeling. Brass finishes of this type give their longest useful life when protected from varying weather conditions. A certain amount of "wobble" is normal and should not be considered a defect. Servicing performed by unauthorized persons shall render the warranty invalid. There is no other express warranty. We hereby disclaims any and all warranties, including but not limited to those of merchantability and fitness for a particular purpose to the extent permitted by law. The duration of any implied warranty which cannot be disclaimed is limited to the time period as specified in the express warranty. Some states do not allow a limitation on how long an implied warranty lasts, so the above limitation may not apply to you. The retailer shall not be liable for incidental, consequential, or special damages arising out of or in connection with product use or performance except as may otherwise be accorded by law. Some states do not allow the exclusion of incidental or consequential damages, so the above exclusion or limitation may not apply to you. This warranty gives specific legal rights, and you may also have other rights which vary from state to state. This warranty supersedes all prior warranties. Shipping costs for any return of product as part of a claim on the warranty must be paid by the customer.

PREPARATION

Before beginning assembly of product, make sure all parts are present. Compare parts with package contents list and hardware contents list, If any part is missing or damaged, do not attempt to assemble the product. If there are any questions relating to defects, missing parts, assembly issues, replacements, or devic connectivity issues, please contact us.

Pre-Installation

SPECIFICATION

Size	Speed	Volts	Amps	Watts	RPM	CFM	Net Weight	Gross Weight	Cube Feet
52 in	Low	120	0.20	11	66	1455	18.1lb	21lb	2.85cu.ft
	Medium		0.31	23	104	3113			
	High		0.45	62	180	5847			

The above data are for reference only, Actually the motor speed of each ceiling fan is a little different. Any products, Subject to actual products as standard.



NOTE: These are approximate measures. They do not include the amps and wattage used by the light kit.

Specifications & measurements shown are subject to+ 5% variations.

Pre-Installation(continued)

TOOLS REQUIRED



Phillips
screwdriver

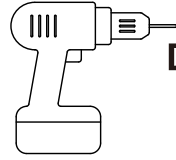

Drill



Electrical
tape

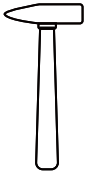

Hammer



Adjustable
wrench

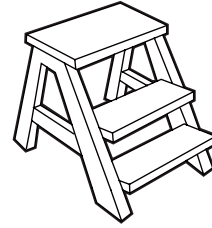

Step ladder

HARDWARE INCLUDED

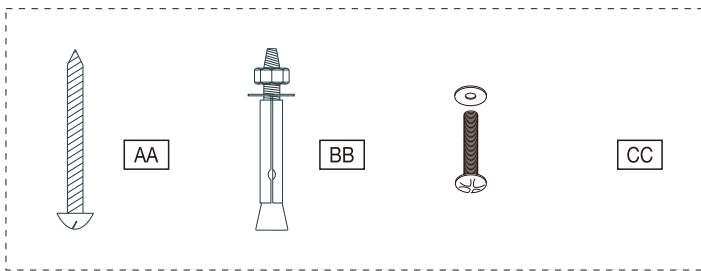

NOTE:Hardware not shown to actual size.

AA	Mounting screws	4
BB	Expansion Bolts	2
CC	Mounting screws and cushion (Outlet box)	2
DD	Blade attachment screw and fiber washer	16
EE	Plastic wire nut(not to scale)	6
FF	Balanced parts package	1
GG	Arm screw and lock washer(preassembled)	11
HH	Downrod assenbly set screw (Preassembled)	3
II	Ceiling Mounting Screws (Preassembled)	3
JJ	shade screw(Preassembled)	3

Pre-Installation(continued)

PACKAGE CONTENTS

 NOTE: Hardware not shown to actual size.

A	Slide-on mounting bracket	1
B	Canopy	1
C	12.5CM Ball/down rod assembly	1
D	25CM Ball/down rod assembly	1
E	Canopy Cover	1
F	Coupling Cover	1
G	Fan-motor assembly	1
H	Shade	1
I	Blade	5
J	Arm (with pre-installed screws)	5
K	Remote control (Transmitter)	1
L	Remote control (Receiver)	1
M	E26 Bulb	3
H1	Acrylic round sheet	1
H2	Nut	1
H3	Hardware cover	1
H4	Hardware decorative ball	1

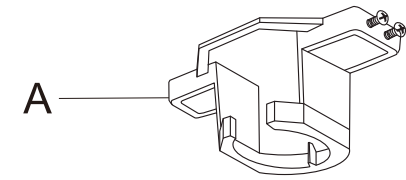

A

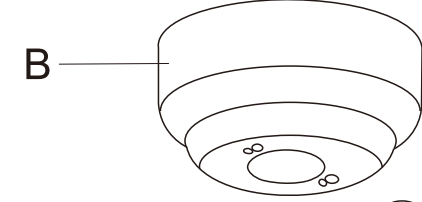

B

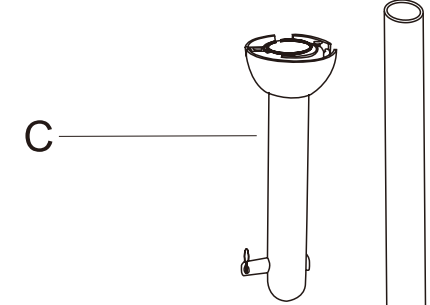

C

D



E



F

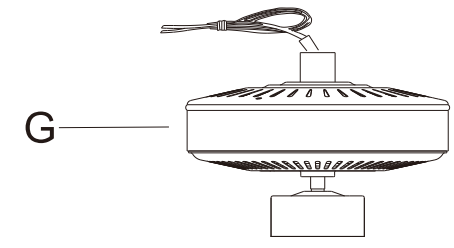

G

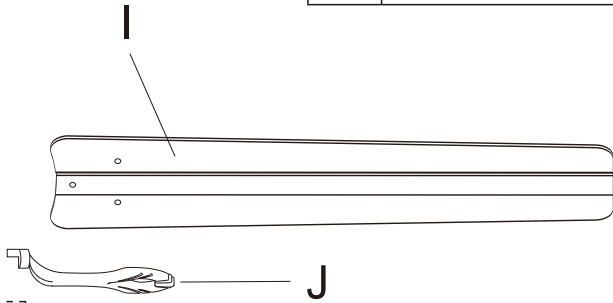

I

J

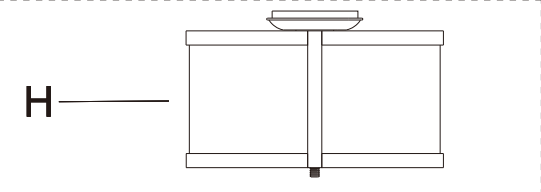

H

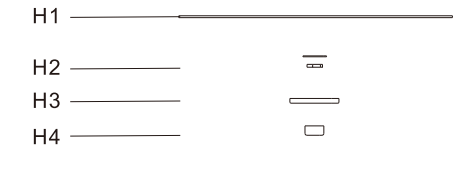

H1

H2

H3

H4

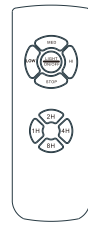

K

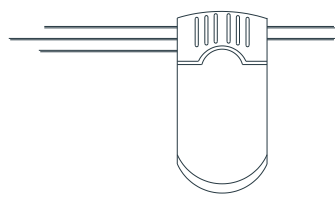

L



M

Installation-Hanging the Fan

Ceiling fans can be installed according to the user's location can be installed in the standard ball, slope ball installation and ceiling installation

Height for Ceiling Mounted: 14"

Height with 5" rod: 19"

Height with 10" rod: 24"

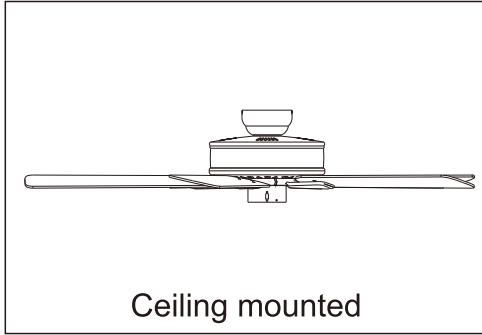

Ceiling mounted

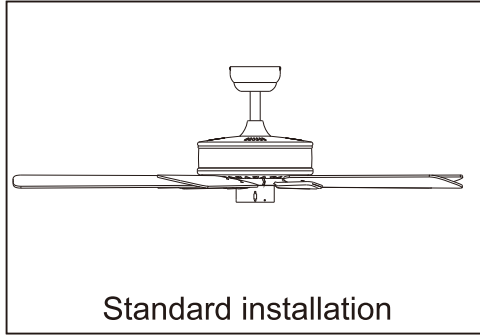

Standard installation

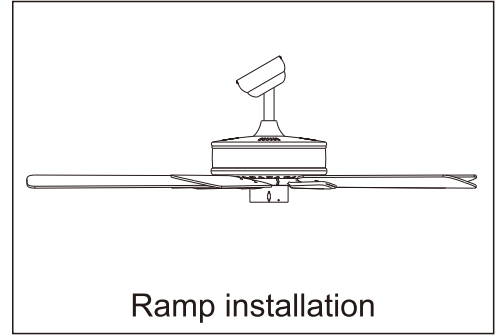

Ramp installation

Standard drop ball installation is suitable for general building installation, ramp drop ball installation is suitable for installation on the inclined plane (inverted as inclined roof). The ceiling type installation is suitable for the lower floor space.

The slope drop ball type installation method is basically the same as the standard drop ball type installation method, except that the location of the hanger installation varies.

Installation - Hanging bracket

MOUNTING OPTIONS

For wooden ceiling, use wood screw to drill on the wooden beam or the "junction box" to fix the hanging bracket (selection is made according to actual requirements of the customers).

STEP 1A-WOODEN CEILING

SWITCH OFF THE ELECTRICAL MAINS AT THE CIRCUIT BREAKER FUSE BOX.

- 1) Use the Mounting Bracket (A) as a guide, mark the spots where the 2 Self Mounting Screws (AA) will be drilled.
- 2) Remove the Mounting Bracket (A), drill 2 holes for 3MM diameter, install the mounting bracket onto wooden ceiling with the 2 Self Mounting Screws (AA).

△ IMPORTANT :SCREWS MUST BE TIGHTENED TILL SNUG

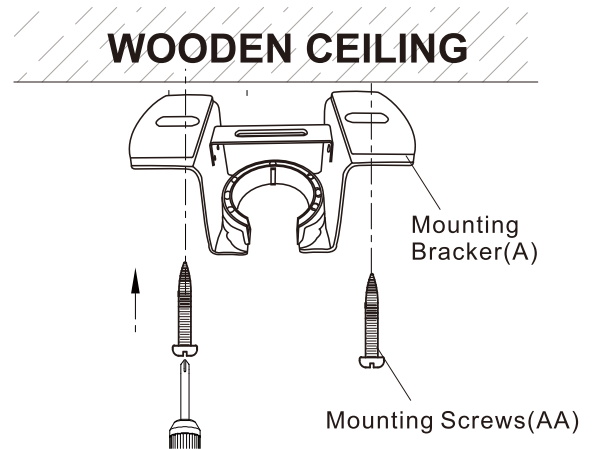

For concrete ceiling, use the percussion bit with diameter 8mm to drill holes according to the length of expansion screws. Then use the attached expansion screws to fix the hanging bracket onto the ceiling (selection is made according to actual requirements of the customers)

STEP 2A-CONCRETE CELING

SWITCH OFF THE ELECTRICAL MAINS AT THE CIRCUIT BREAKER FUSE BOX.

- 1) Use the Mounting Bracket (A) as a guide, mark the spots where the 2 Expansion Bolts(BB) will be drilled.
- 2) Remove the Mounting Bracket (A). Drill 2 holes for 8MM diameter and insert 2 Expansion Bolts (BB) into the concrete ceiling, install the mounting bracket and secure with Flat Washers(BB1), Spring Washers(BB2) and Nuts(BB3)

△ IMPORTANT :SCREWS MUST BE TIGHTENED TILL SNUG

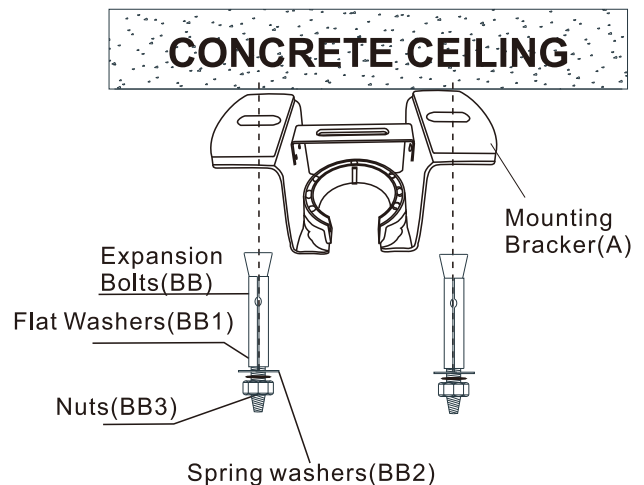

Installation - Hanging bracket(continued)

MOUNTING OPTIONS



WARNING: To reduce the risk of fire, electric shock or personal injury, mount to an outlet box marked "Acceptable for fan support of 35 lbs. (15.9 kg) or less," and use the screws provided with the outlet box. An outlet box commonly used for the support of lighting fixtures may not be acceptable for fan support and may need to be replaced. If in doubt, consult a qualified electrician.

If your ceiling fan does not have an existing UL mounting box, then install one using the following instructions:

- Disconnect the power by removing the fuses or turning off the circuit breakers.
- Secure the outlet box directly to the building structure. Use the appropriate fasteners and materials. The outlet box and its bracing must be able to fully support the weight of the moving fan (at least 35 lbs.). Do not use a plastic outlet box.

The illustrations below show three different ways to mount the outlet box.

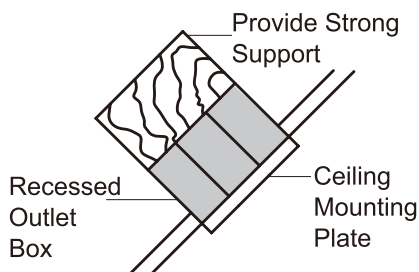
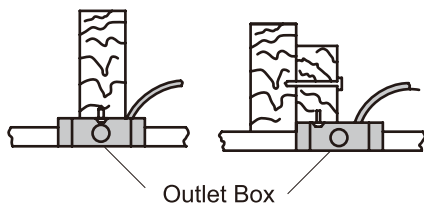
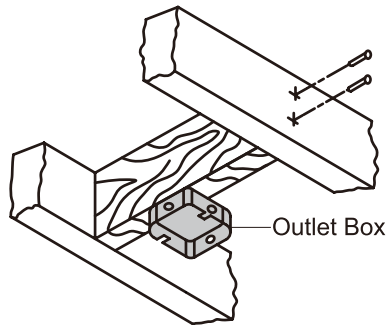

NOTE : You may need a longer downrod to maintain proper blade clearance when installing on a steep, sloped ceiling. The maximum angle allowable is 20° away from horizontal.

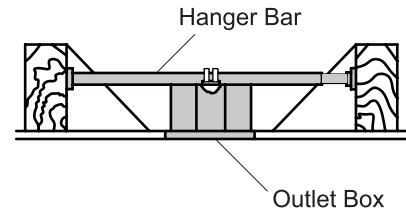

If the canopy (B) touches the ball/downrod assembly (C), then remove the decorative canopy bottom cover and turn the canopy (C) 180° before attaching the canopy (B) to the mounting plate.

To hang your fan where there is an existing fixture but no ceiling joist, you may need an installation hanger bar as shown above

Assembly1-Standard Ceiling Mount

1.Preparing for standard mounting



NOTE: The magnet is pre-attached on the canopy bottom cover for you to remove and install easily.

- loosen the two bracket screws(A1) located on the bottom of the mounting bracket (A), and turn the canopy counter clockwise to remove the mounting bracket (A) from the canopy(B).

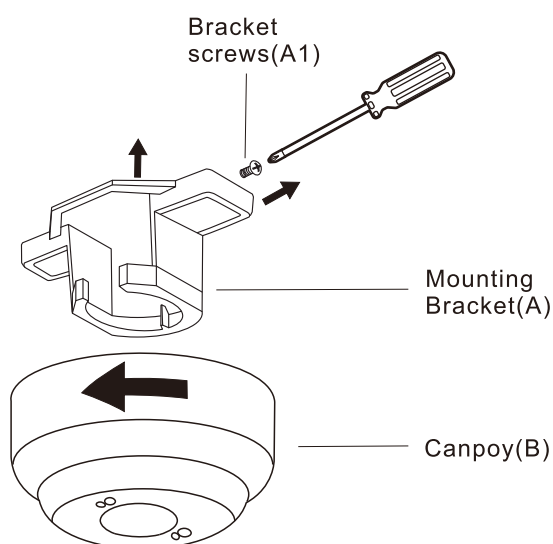

2.Attaching the fan to the electrical box



WARNING: To reduce the risk of fire, electric shock or personal injury, mount to an outlet box marked "Acceptable for fan support of 35 lbs.(15.9 kg) or less," and use the screws provided with the outlet box.

- Pass the 120-Volt supply wires through the center hole in the slide-on mounting bracket (A).
- Install the mounting bracket (A) on the outlet box by the two screws(CC) provided with the outlet box.
- Securely tighten the two mounting screws (CC).

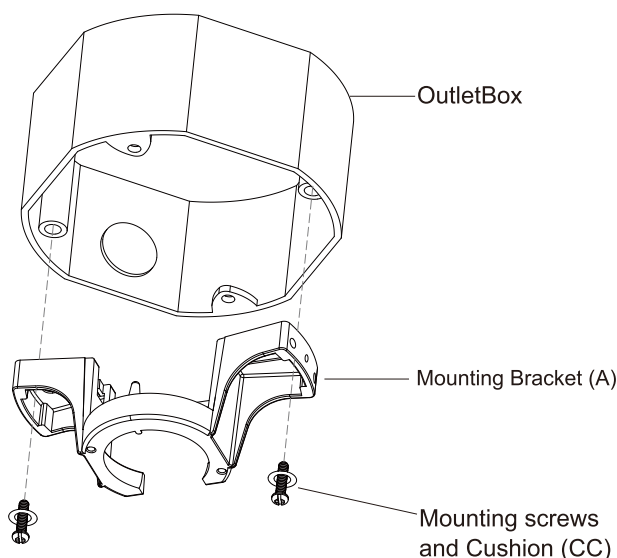

Option 1-Flushmount installation (continued)

3. Install flushmount assembly



NOTE: If lifting is required, skip steps 3-5 ; if flushmount installation is required, skip steps 5-8

- Loosen the set screws in the Support Rod Coupler(PP) located on the top center of the motor housing until the inside channel is clear.
- Remove and save the larger three mounting screws (II) from the connector.
- Place the Canopy(B) on the top of the motor housing, align the three small holes of the Canopy (B) with the holes where the screws were just removed, and secure with the three Mounting Screws(II).

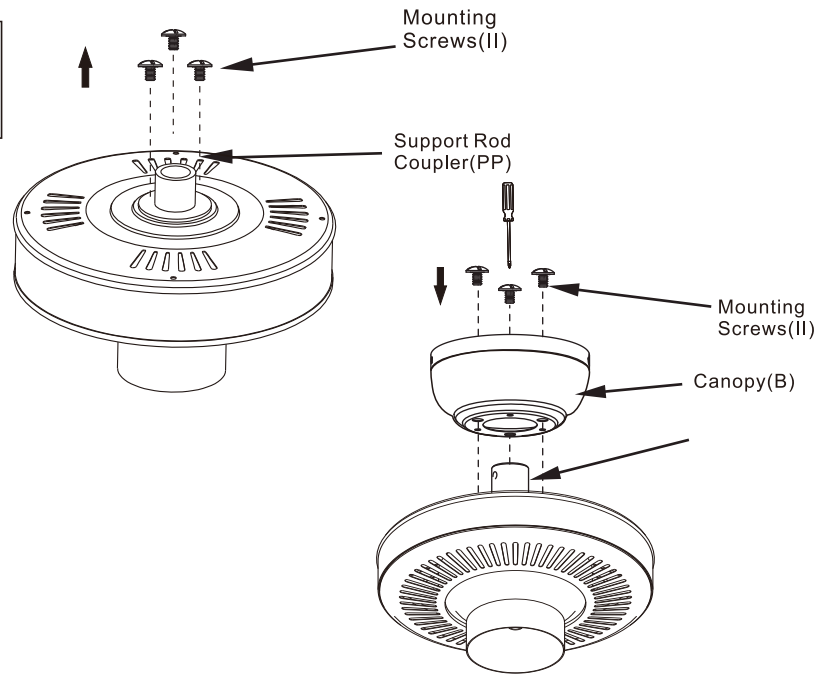

4. Flushmount Installation



NOTE: Before installing the canopy, wire it first, refer to step 9 on page 11 for wiring reference

- Slide the canopy up into place over the ceiling Mounting Bracket (A). Loosen up the canopy screws on the side of the canopy screws. Press the Canopy (B) against the mounting bracket and turn it clockwise. Tighten screws on the J Slots and install the two screws in the remaining holes.

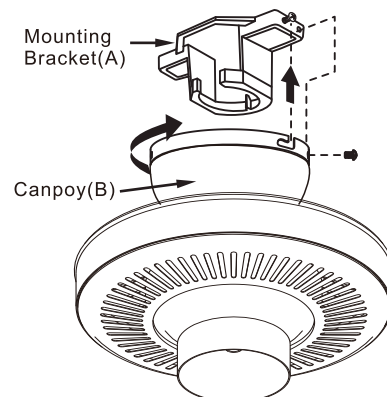

Option 2-The Downrod installation(continued)

5. Remove the hanger ball



NOTE: If lifting is required, skip step 4-5 ; if flushmount installation is required, skip step 6-8

- Remove the Hanger ball(CC2) from the Downrod assembly(C) by loosening the set screw (HH) and removing R-shaped, the metal Pin (CC1) and Pin (CC3) as shown. Keep parts .

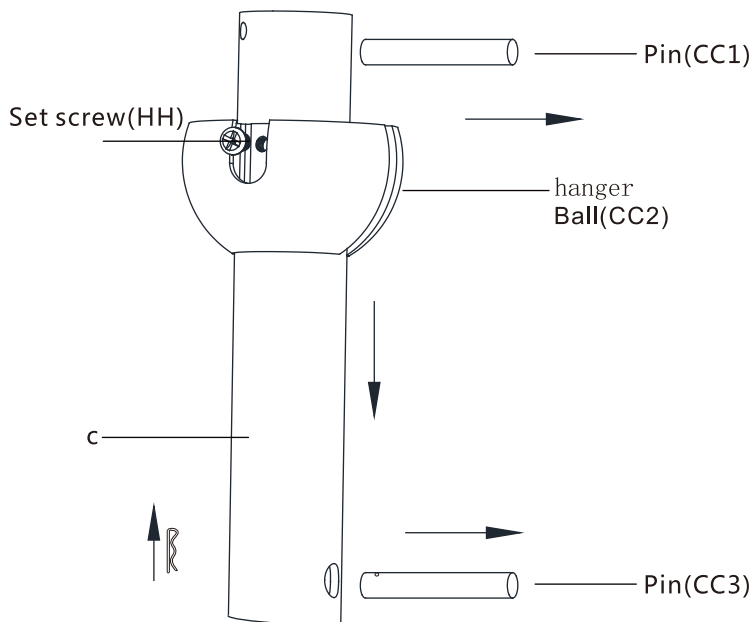

6. Install hanger rod



NOTE: Equipped with two long and short suspension rods (C) and (D) for installation. Choose one according to your own needs.

- Thread the top outlet wire of the Fan Motor Assembly (G) through the down rod (C/D).
- Loosen the Set Screw (HH) on the top motor ring (PP) of the fan motor assembly (G)
- Install the down rod (C/D), insert the down rod (C/D) into the motor coupling (PP), and secure it with a metal Pin (CC3). Secure with R-shaped clips.
- Tighten the Set Screw (HH) on the motor ring (PP) again, so that the set screw (HH) is firmly pressed onto the down rod (C/D) .

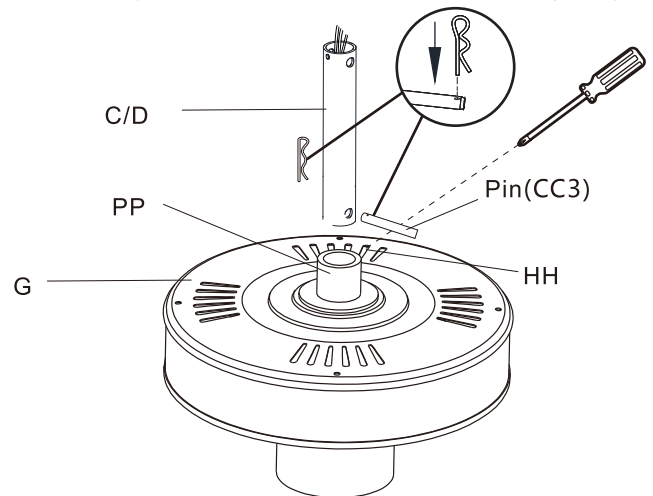

7. Assembling the fan



WARNING: make sure the pin installed well on hanger ball with downrod

- Place the Coupling cover (F), Canopy cover (E), and Canopy (B) on the lead and Downrod assembly (C/D). Secure the Hanger ball with a pin (CC1) and a set screw. Tighten the set screw to secure the Downrod assembly (C/D).

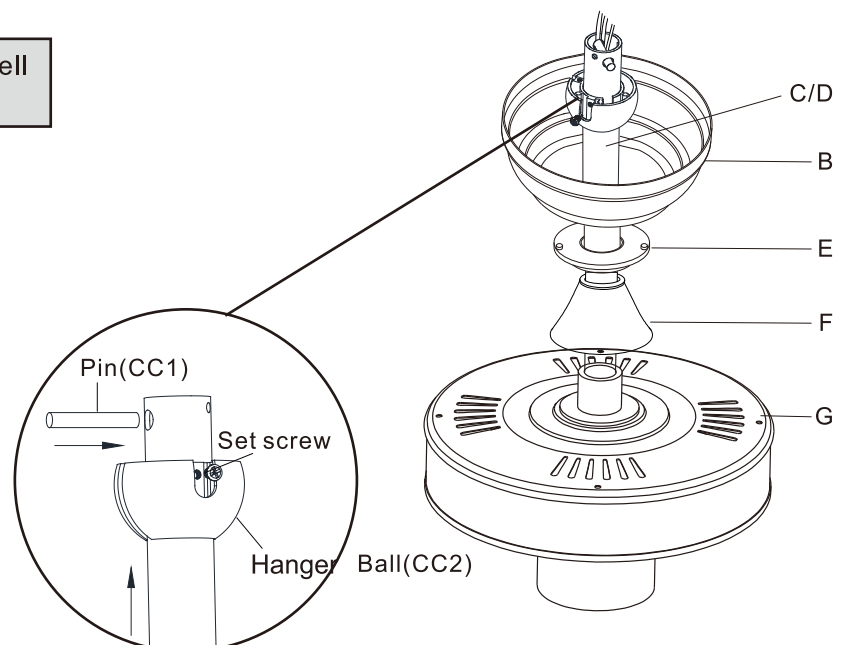

Option1-Flushmount installation (continued)

8. Hanging the fan

- Notice the half ball on the end of the Support Rod is grooved down one side. This key way fits over the small Keyway Pin(S) on the inside of the Mounting Bracket(A) and keeps the ceiling fan from spinning on the Mounting Bracket(A).
- Using your step ladder, lift the fan and place the half ball in the center of the Mounting Bracket(A) with the Keyway Pin(S) inserted into the keyway on the ball. Turn the fan left and right slightly to make sure it is seated on the bracket with the Keyway Pin(S) in the keyway.

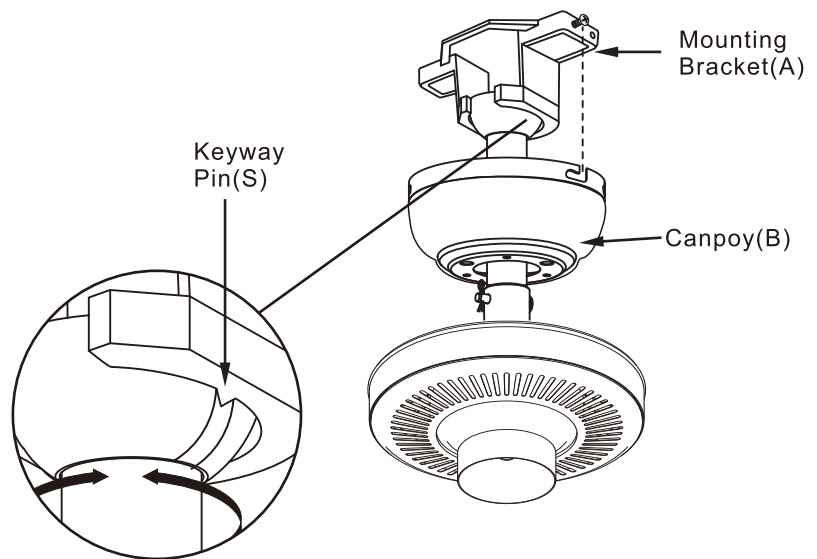

9. Wire connection



WARNING: To avoid possible electrical shock, turn the electricity off at the main fuse box before wiring. If you feel you do not have enough electrical wiring knowledge or experience, contact a licensed electrician.



WARNING: Each wire nut supplied with this fan is designed to accept up to one 12-gauge house wire and two wires from the fan. If you have larger than 12-gauge house wiring, or more than one house wire to connect to the fan wiring, consult an electrician for the proper size wire nuts to use.

- Spread the wires apart so that the green and white wires are on one side of the outlet box and the black wire is on the other side.
- Connect the green fan wires to the household ground wire (this may be a green or bare wire) using a wire connecting nut (EE).
- Connect the receiver (L) black or red wire to the household black (hot) wire using a wire connecting nut (EE).
- Connect the receiver (N) white wire to the household white wire (neutral) using a wire connecting nut (EE).
- Secure each wire connecting nut using electrical tape.

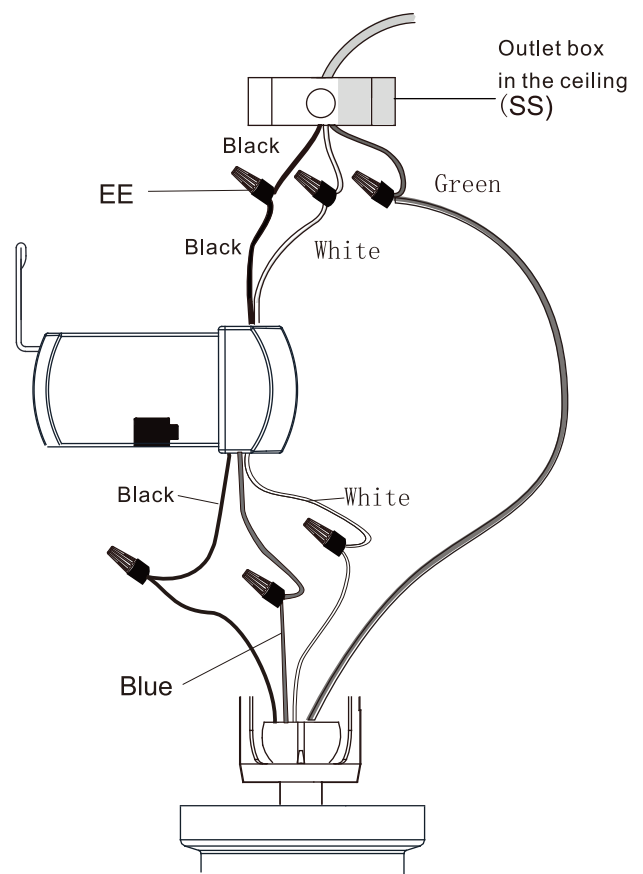

**Electrical
tape**

Assembly-Hanging the Fan(continued)

10. Install remote control

- Place the Receiver(L) on the Mounting Bracket(A)
- Carefully push the Canopy(B) to the bottom of the Mounting Bracket(A), make two sliding holes aligned to the two prominent screws on the Mounting Bracket(A), and then turn clockwise until tight.
- Push the canopy cover to the bottom of the Canopy(B), slide the inner holes aligned to the two prominent screws on the Mounting Bracket(A) again, and turn the canopy ring clockwise until tight.

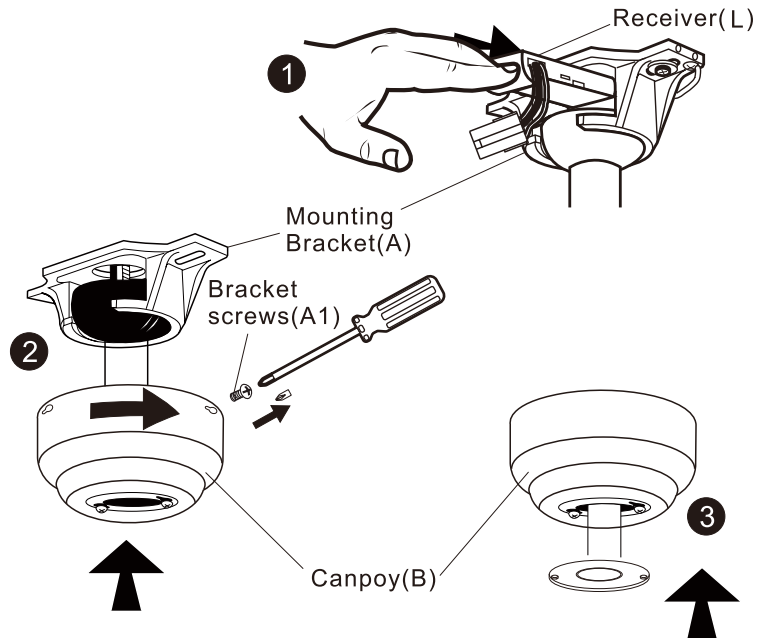

11. Attaching the blades to the arms

- Pass the Red Washer(DD1) through the Blade Attachment Screw(DD2).
- Tighten the Screw(DD2) through the Blade(I) and tighten it on the Arms(J).
- Repeat the above steps to tighten the four sets of blades.

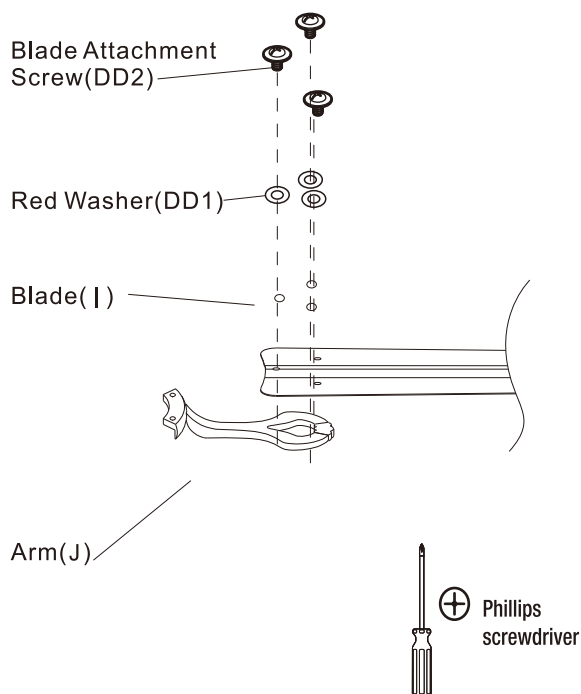

12. Fastening the blade arms to the motor



WARNING: Remove the rubber motor stops on the bottom of the fan before installing the blades or testing the motor.



NOTE: Your fan features revolutionary advancements for quick and easy blade installation. Including an alignment post and captive blade arm screws.



NOTE: Your fan blades are reversible. Select the blade side finish which best accentuates your decor.

- 1: Fasten the arm to the Fan-motor Assembly(G) by inserting the alignment post into the slot on the bottom of the motor and tightening the pre-installed Arm Screws(GG).
- Repeat this step for the remaining blade assemblies

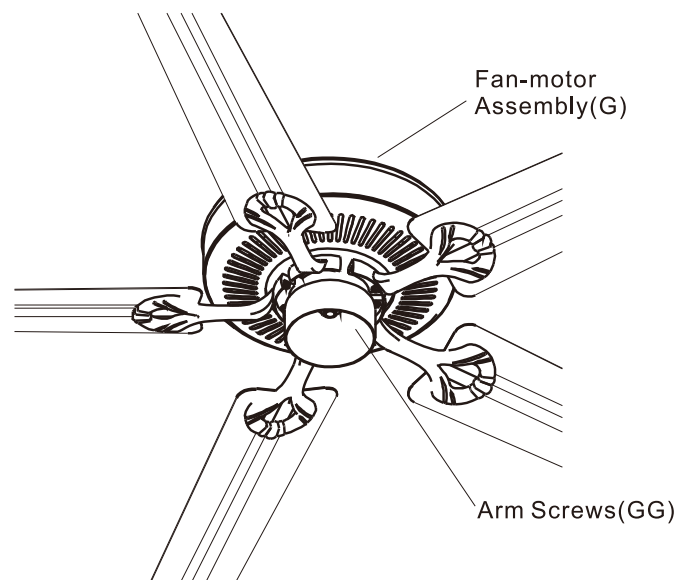

Assembly-Attaching the Lights

13. Connecting lamp wire



CAUTION: To reduce the risk of electric shock, disconnect the electrical circuit to the fan before installing the light fixture.

- Insert the "white" line in the switching box of the motor into the "white" line of the light and tie insulated rubber tape.
- Insert the "Black" line in the switching box of the motor into the "Black" line of the light and tie insulated rubber tape.

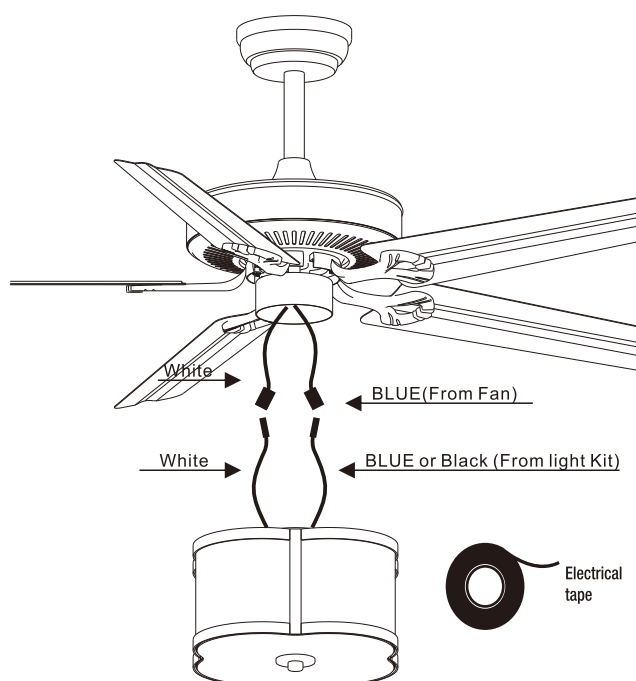

14. Tighten the screw of the box cover

- Take the wire into the shade(H) of the motor
- Align the opening of shade (H) of the light at switch locking position of the positive and negative rotation of the motors witching box. Place the cover. Screw in the Screw(JJ) of the shade(H).

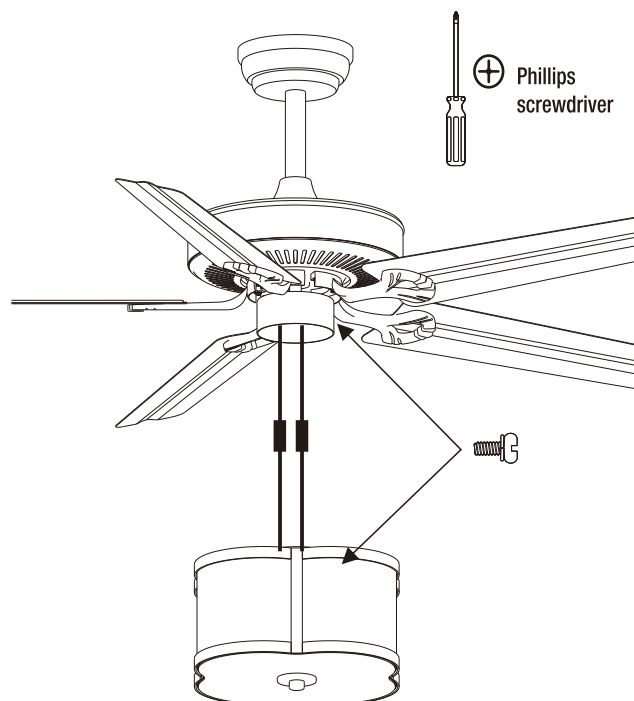

Assembly-Attaching the Lights

15. Attaching the lamp bulbs

- Take out three lamp bulbs (M) from the packaging box and install them on the lamp holders inside the crystal shade(H). Rotate them clockwise to install and tighten the lamp bulbs(M).
- Please use Type "A" bulb MAX 40-watt or led bulb MAX 9-watt, there is led 4-watt bulb in the box.

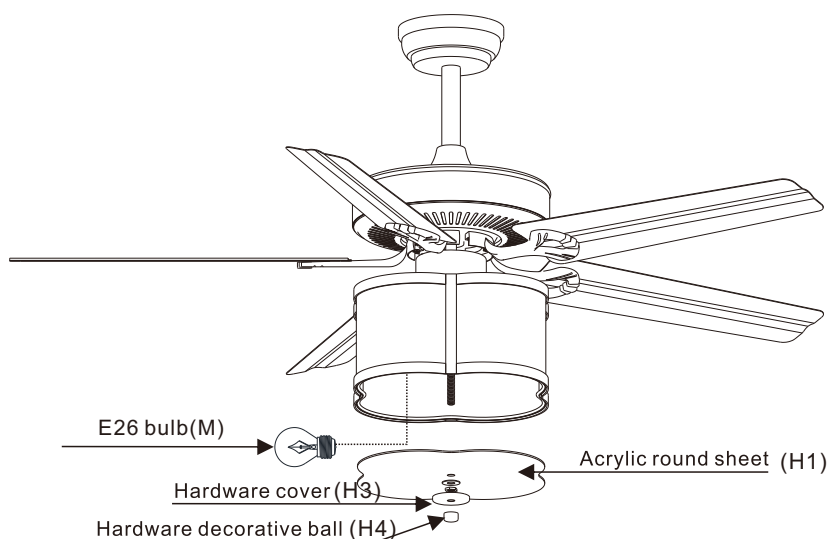

Operation

OPERATING YOUR FAN

Turn on the power and check the operation of the fan. The remote controls the fan speed and light.

The appropriate speed settings for warm or cool weather depends on factors such as the room size, ceiling height, and number of fans.

The slide switch (XX) controls the direction of the blades: forward (switch down) or reverse (switch up).



NOTE: Wait for the fan to stop before reversing the direction of the blade rotation

A. Warm weather-(Forward) A downward airflow creates a cooling effect. This allows you to set your air conditioner on a higher setting without affecting your comfort.

B. Cool weather-(Reverse) An upward airflow moves warm air off of the ceiling. This allows you to set your heating unit on a lowering setting without affecting your comfort.

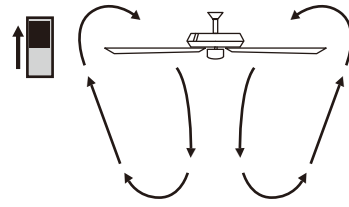

A. Warm Weather
(summertime)

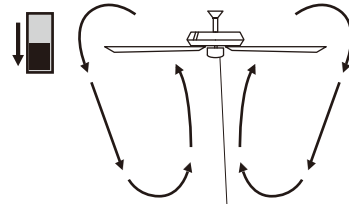

B. Cool Weather
(wintertime)

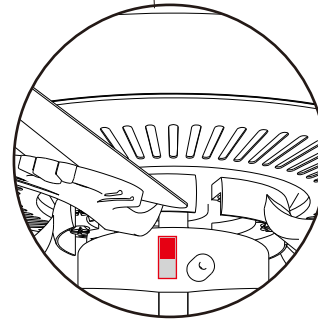

Use of remote control



LIGHT NO/OFF

- 1H** Auto off after 1hr
- 2H** Auto off after 2hr
- 4H** Auto off after 4hr
- 8H** Auto off after 8hr

- LOW** Fan Speed Low level
- MED** Fan Speed Middle level
- HI** Fan Speed High level
- STOP** Fan Stop

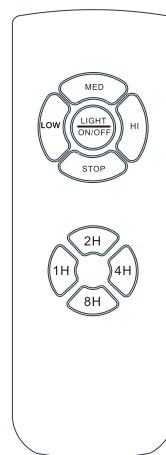

Preparing the remote control



NOTE: The frequencies on your receiver and remote control have been preset at the factory.



NOTE: The battery will weaken with age and should be replaced before leaking takes place, as battery leakage damages the hand unit. Dispose of the used battery properly and keep the battery out of the reach of children.

- Remove the remote control (K) battery cover by pressing firmly on the arrow and sliding the cover off.
- Install two 1.5V batteries (do not included).
- Replace the battery cover on the remote control (K)

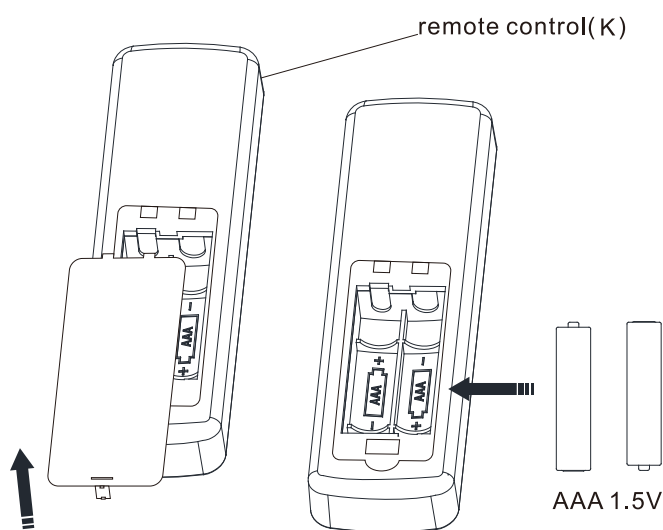

Installing remote control bracket



NOTE: Screw wall anchors are included for extra support. The included screws are designed to screw easily into the wall. If you would like a more permanent or secure hold, install the wall anchors prior to attaching the wall cradle to the wall.

- Position the wall cradle in the desired position and attach it to the wall using the included wall cradle screws.

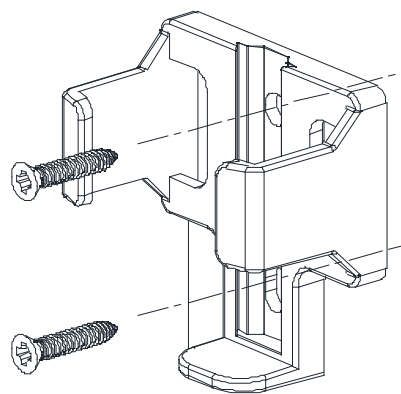

Fans Balance

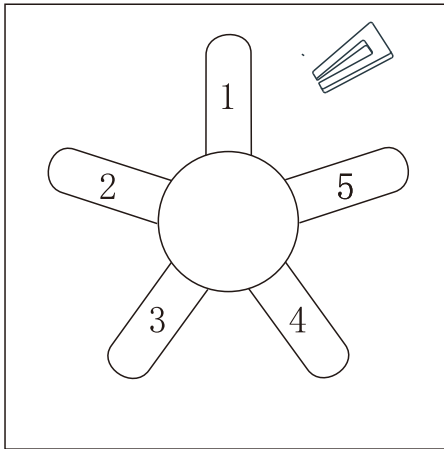

Put the clip in the center of a blade. Turn on the fan and, if the rolling persists, put the clip in another blade until the roll is reduced. It will be the blade that will need the counterweight.

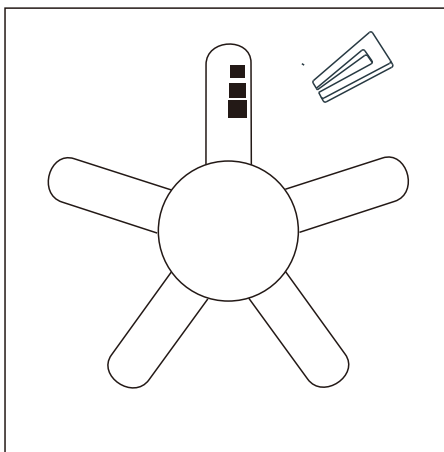

Place the clip on the blade that needs the counterweight and try the best place to place it, from the center to the tip of the blade, until the wobble disappears.

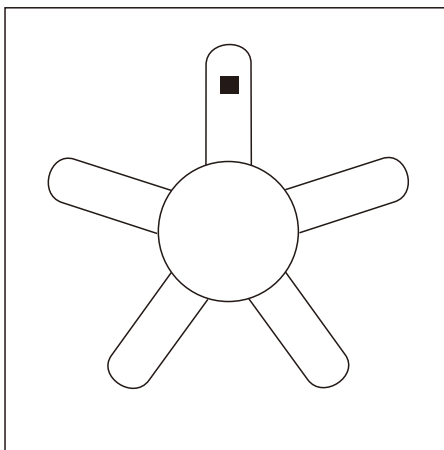

Glue the counterweight to the height of the clip on the surface of the blade. Remove the clip and test the fan. If you keep staggering, put another counterweight. If it gets worse, try another better area to place it.

Care and Cleaning



WARNING: Make sure the power is off before cleaning your fan.

- Because of the fan's natural movement, some connections may become loose. Check the support connections, brackets, and blade attachments twice a year. Make sure they are secure. It is not necessary to remove the fan from the ceiling.
- Clean your fan periodically to help maintain its new appearance over the years. Do not use water when cleaning, as this could damage the motor or the wood, or possibly cause an electrical shock. Use only a soft brush or lint-free cloth to avoid scratching the finish. The plating is sealed with a lacquer to minimize discoloration or tarnishing.
- You can apply a light coat of furniture polish to the wood for additional protection and enhanced beauty. Cover small scratches with a light application of shoe polish.
- You do not need to oil your fan. The motor has permanently-lubricated sealed ball bearings.

Troubleshooting

Problem	Solution
The fan will not start.	<ul style="list-style-type: none"> <input type="checkbox"/> Check the main and branch circuit fuses or breakers. <input type="checkbox"/> Check the line wire connections to the fan and switch wire connections in the switch housing.
The fan will not start.	<ul style="list-style-type: none"> <input type="checkbox"/> Ensure all motor housing screws are snug. <input type="checkbox"/> Ensure the screws that attach the fan blade bracket to the motor hub are tight. <input type="checkbox"/> Ensure the wire nut connections are not rattling against each other or the interior wall of the switch housing. <input type="checkbox"/> Allow a 24-hour "breaking in" period. Most noises associated with a new fan disappear during this time. <input type="checkbox"/> If you are using the Ceiling Fan light kit, ensure the screws securing the glassware are tight. Check that the light bulbs are also secure. <input type="checkbox"/> Ensure the canopy is a short distance from the ceiling. It should not touch the ceiling. <input type="checkbox"/> Ensure your outlet box is secure and rubber isolator pads were used between the mounting plate and outlet box.
The fan wobbles.	<ul style="list-style-type: none"> <input type="checkbox"/> Check that all blade and blade arm screws are secure. <input type="checkbox"/> Most fan wobble problems are caused when blade levels are unequal. Check this level by selecting a point on the ceiling above the tip of one of the blades. Measure from a point on the center of each blade to the point on the ceiling. Measure this distance. Rotate the fan until the next blade is positioned for measurement. Repeat for each blade. Any measurement deviation should be within 1/8 in. Run the fan for ten minutes. If the fan continues to wobble please refer the page 10

