

ASSEMBLY INSTRUCTION

RATTAN SOFA SET



Notice

- 1. 50% Tighten before fixings all screws, Allen wrench is recommended instead of an electric drill.**
- 2. Place the item on a flat ground to adjust and make sure it remains stable.**
- 3. Tighten up all screws with tools gradually.**
- 4. If the screws are not aligned with holes during assembly, please loosen all all the other screws to 50% and continue the assembly process.**
- 5. If the item is not stable, please loosen all the screws, adjust it on a flat ground and tighten up all screws again.**
- 6. Note: If one or more screws are fully tightened during assembly, chances are the others will not be aligned with holes. In addition, all the holes are designed to be relatively larger to provide more space for the adjustment of the screws.**

(x2)

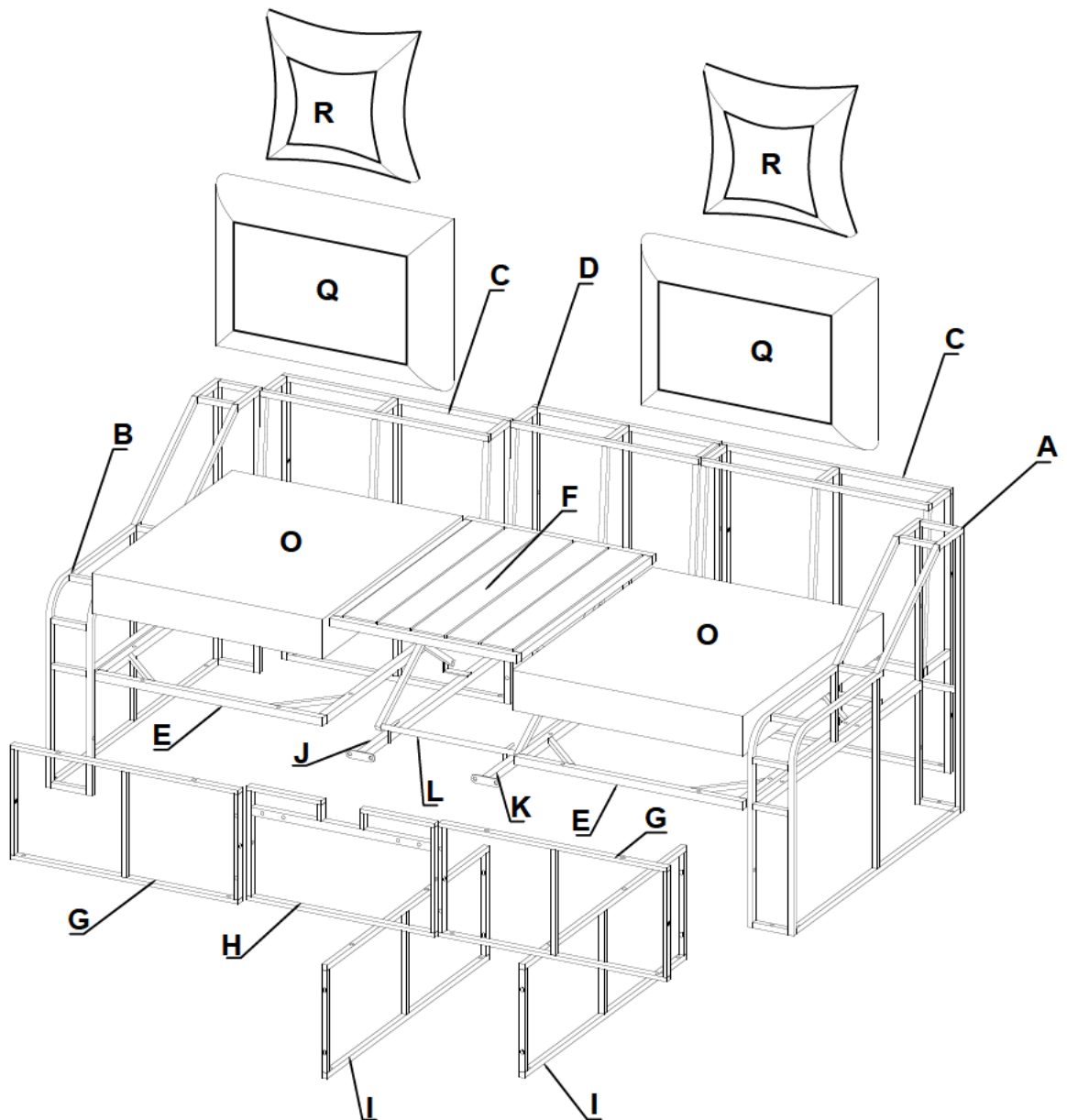
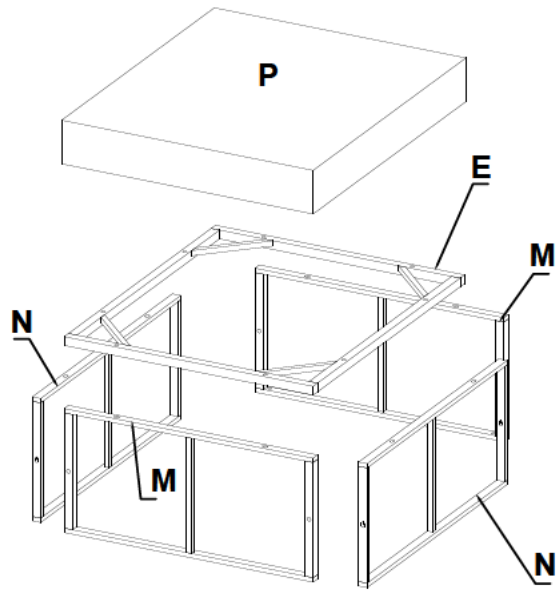

Part list & Hardware

A



1 pc

B



1 pc

C

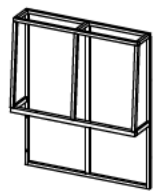

2 pcs

D

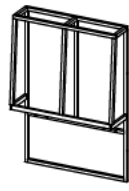

1 pc

E



4 pcs

F

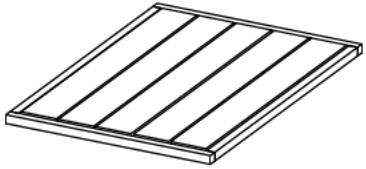

1 pc

G

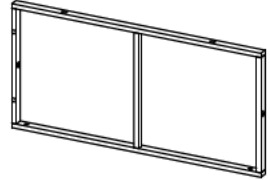

2 pcs

H

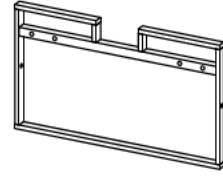

1 pc

I

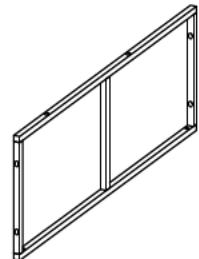

2 pcs

J

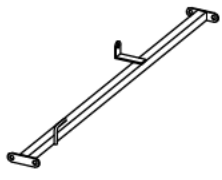

1 pc

K

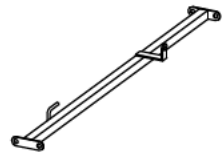

1 pc

L

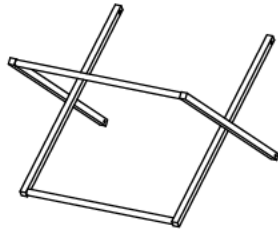

1 pc

M

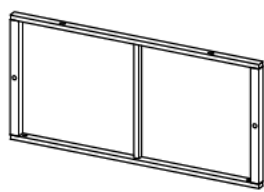

4 pcs

N

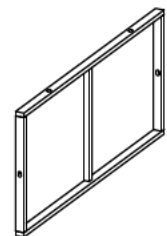

4 pcs

O

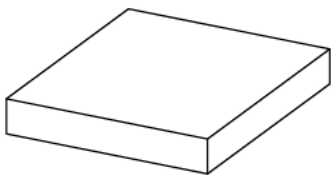

2 pcs

P

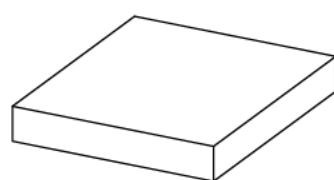

2 pcs

Q

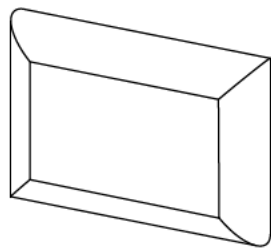

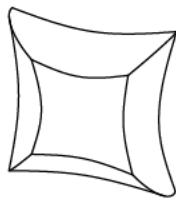

2 pcs

R

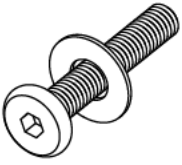
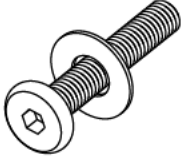

2 pcs

Part list &Hardware

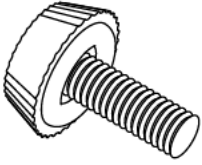
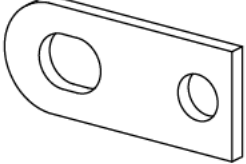
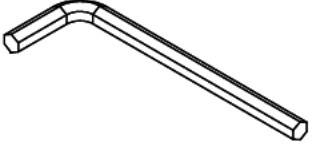
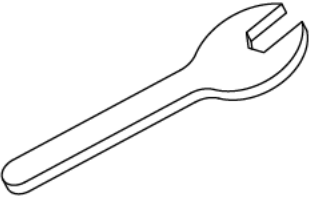
<p>1</p>  <p>Bolt M6x15 mm (24 pcs)+extra 2pcs</p>	<p>2</p>  <p>Bolt M6x30 mm (60 pcs)+extra 3 pcs</p>	<p>3</p>  <p>Nut M6(4 pcs)+extra 1pc</p>
<p>4</p>  <p>Plastic feet (28 pcs)</p>	<p>5</p>  <p>Connector (8 pcs)</p>	<p>6</p>  <p>Allen key M4 (1 pc)</p>
<p>7</p>  <p>Spanner (1 pc)</p>		

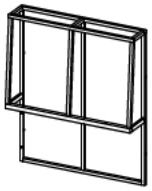

C*2

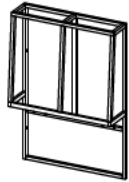

D*1

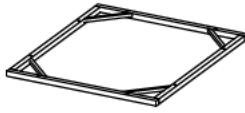

E*2

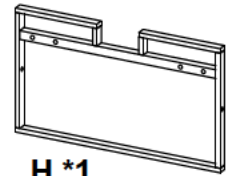

H*1

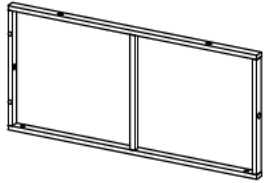

G*2

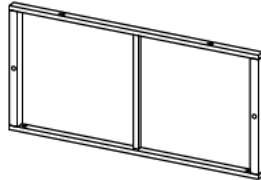

M*4

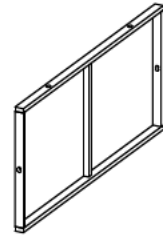

N*4

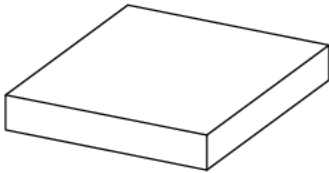

O*2

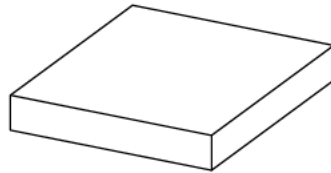

P*1



HARDWARE



A*1



B*1

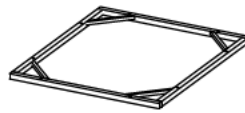

E*2

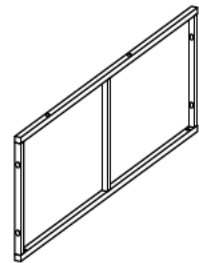

I*2

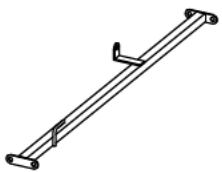

J*1

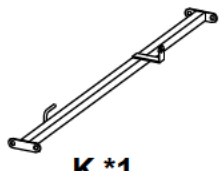

K*1

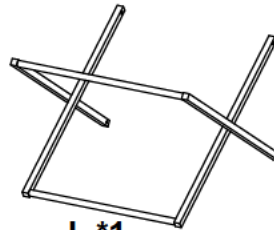

L*1

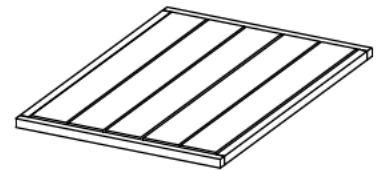

F*1

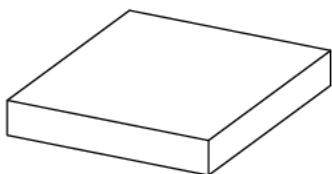

P*1

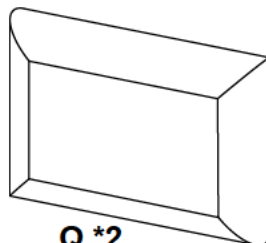

Q*2

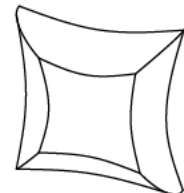

R*2

STEP 1

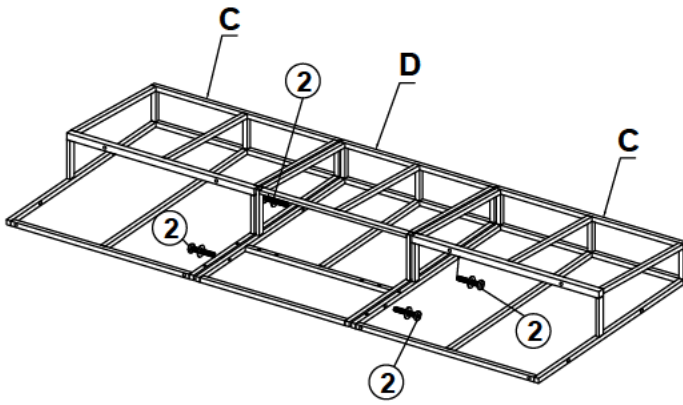
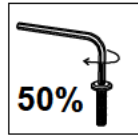
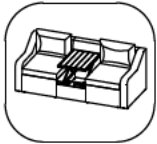

2*4

STEP 2

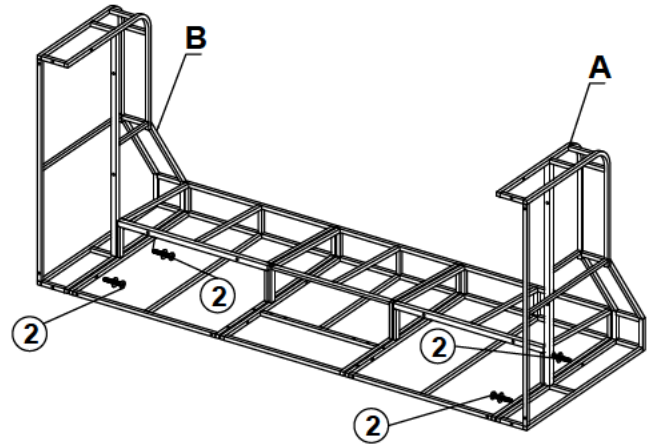
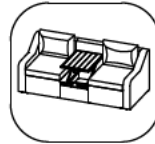

2*4

STEP 3

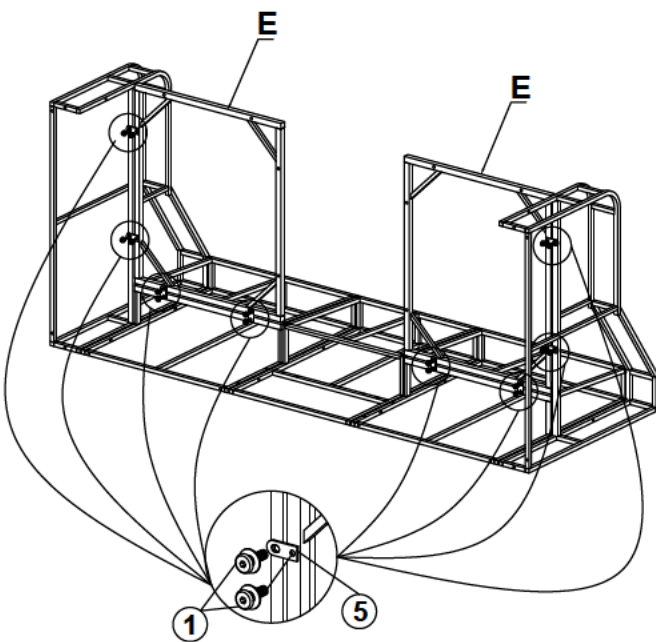
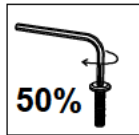
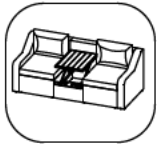

1*16 5*8

STEP 4

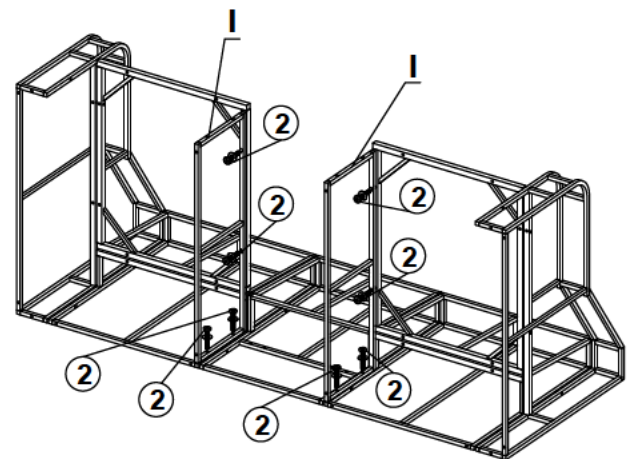
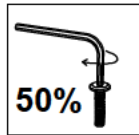
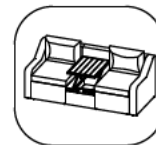

2*8

STEP 5

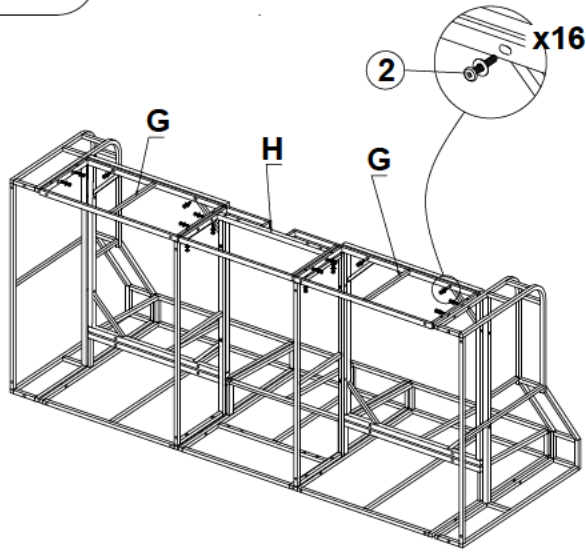
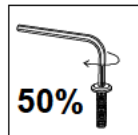
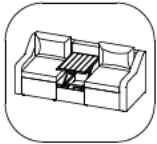

2*16

STEP 6

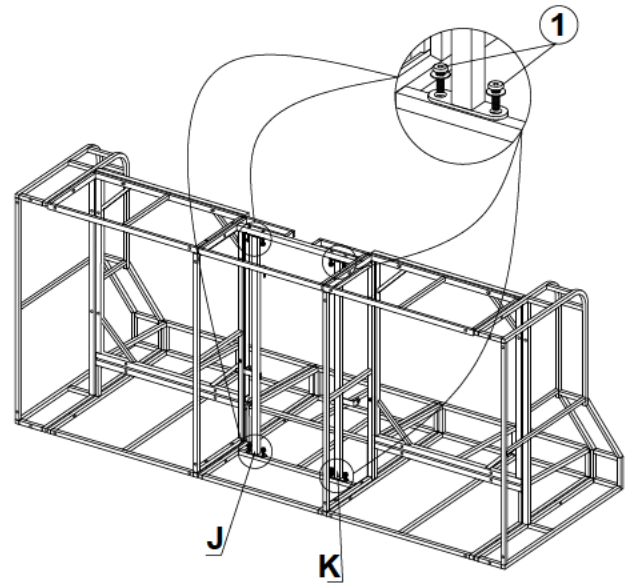
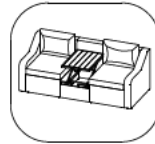

1*8

STEP 7

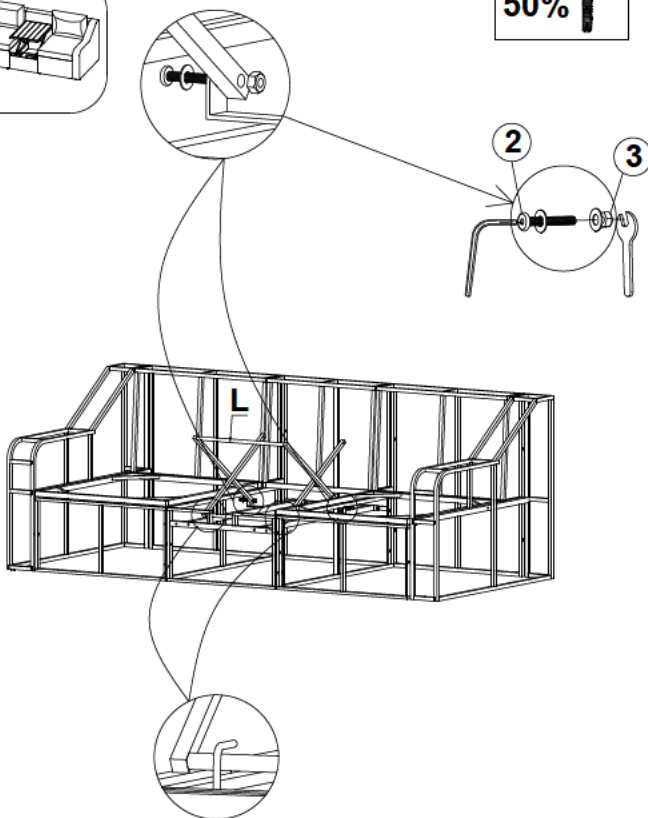
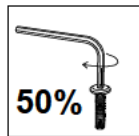
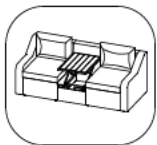

2*2 3*2

STEP 8

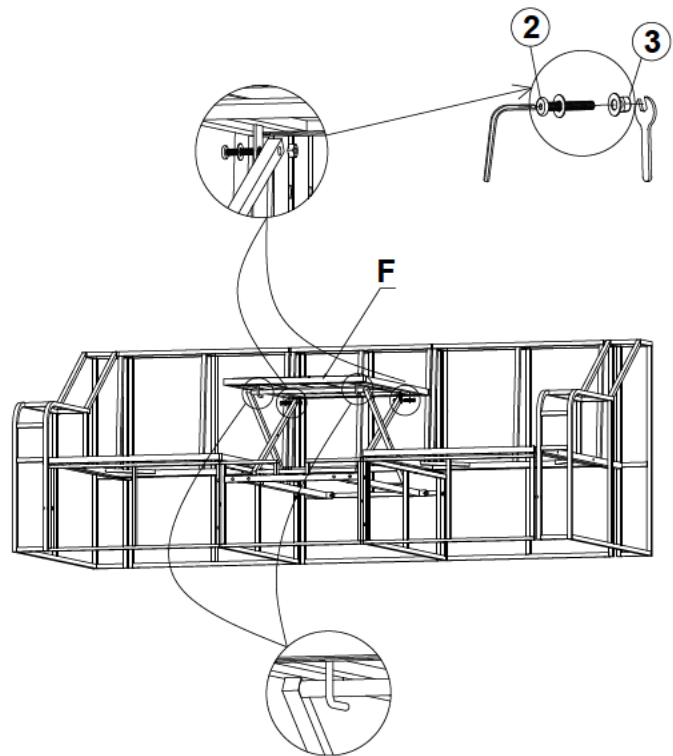
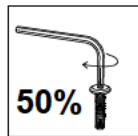

2*2 3*2

STEP 9

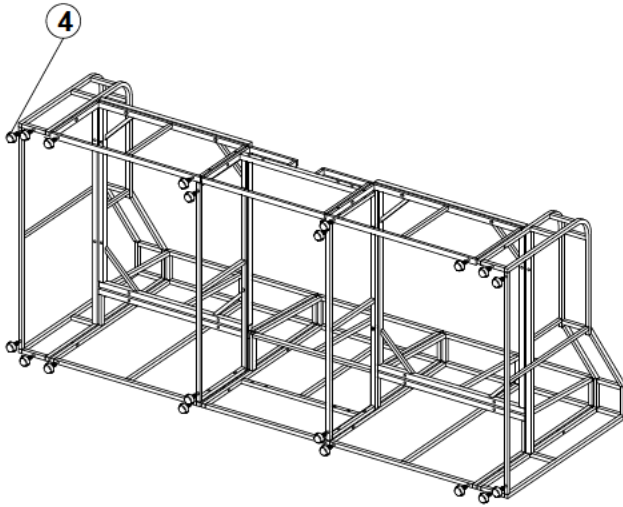
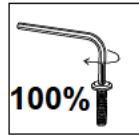

STEP 10

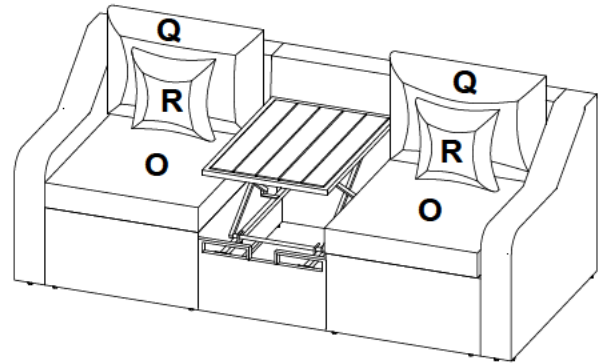
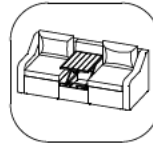

4*20

STEP 11x2

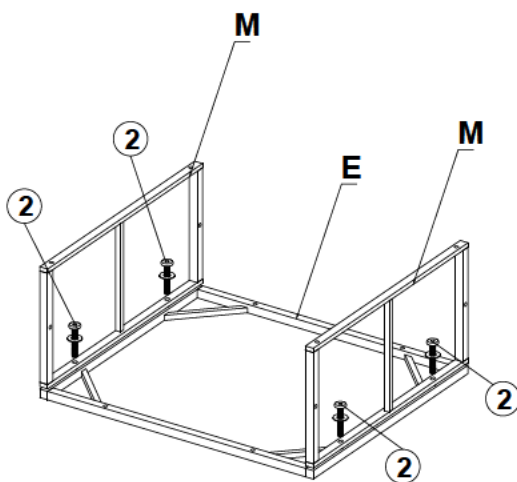
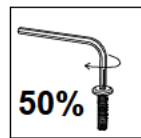
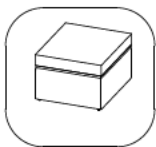

STEP 12x2

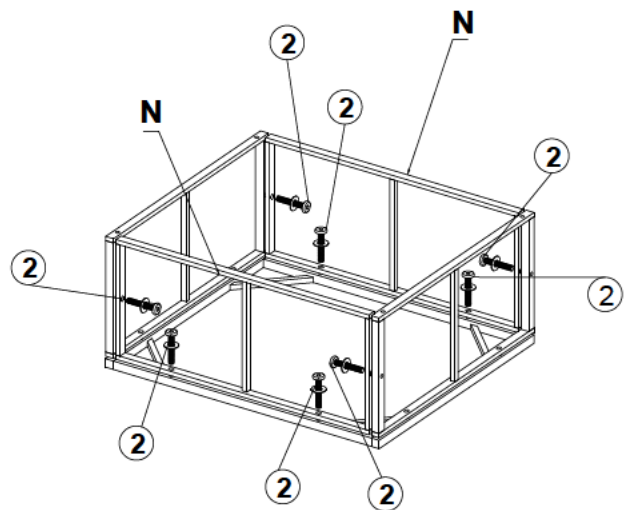
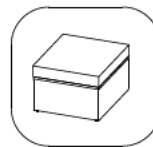

2*4

2*8

STEP 13x2

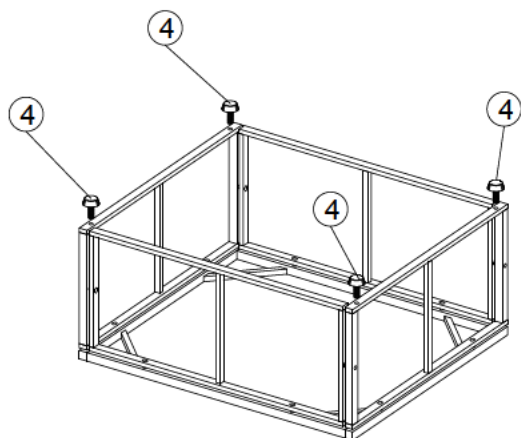
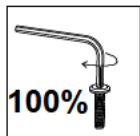
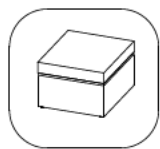

STEP 14x2

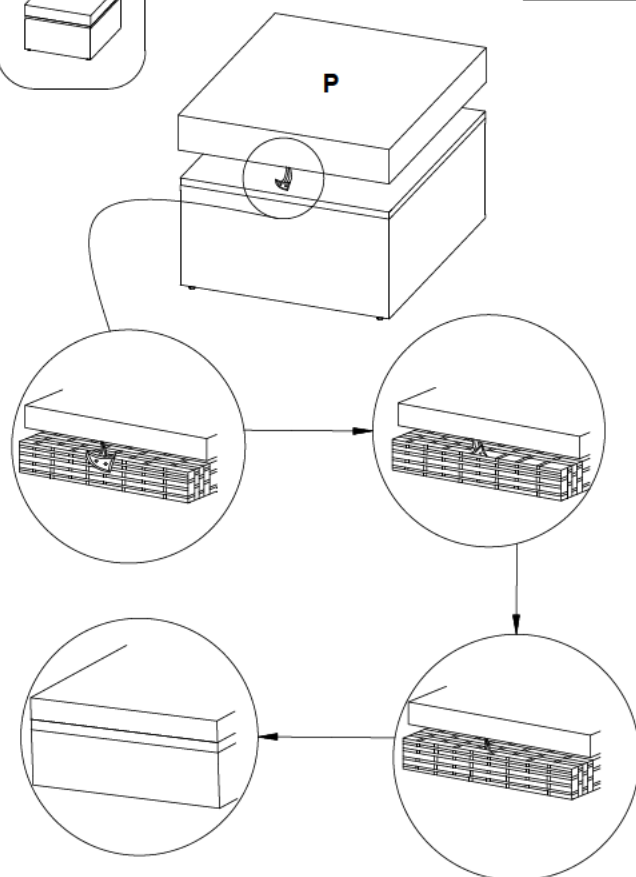
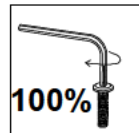
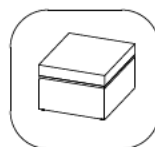

4*4

STEP 15

