

ASSEMBLY INSTRUCTIONS

QUEEN BED

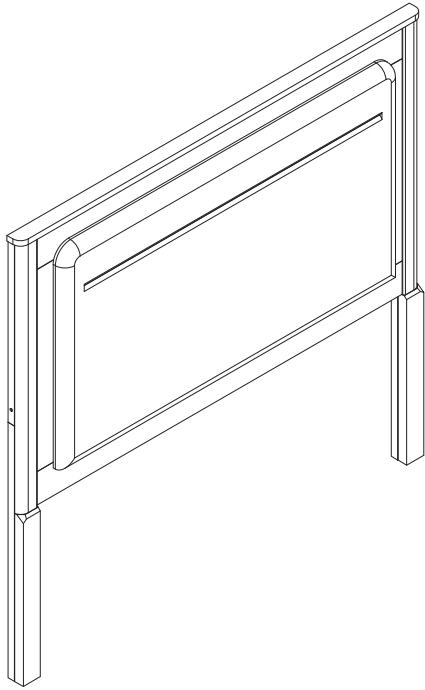

COMPLETED.

PARTS LIST

NO	DESCRIPTION	QTY
1	HEADBOARD	1 PC.
2	HEADBOARD LEG (L)	1 PC.
3	HEADBOARD LEG (R)	1 PC.

HARDWARE LIST

NO	DESCRIPTION	SIZE	QTY
A	JCBB	M8 x 40mm	6 PCS.
B	SPRING WASHER	M8 x 18mm	6 PCS.
C	FLAT WASHER	M8	6 PCS.
D	ALLEN KEY	M4	1 PC.



TOOL REQUIRED (NOT PROVIDED)

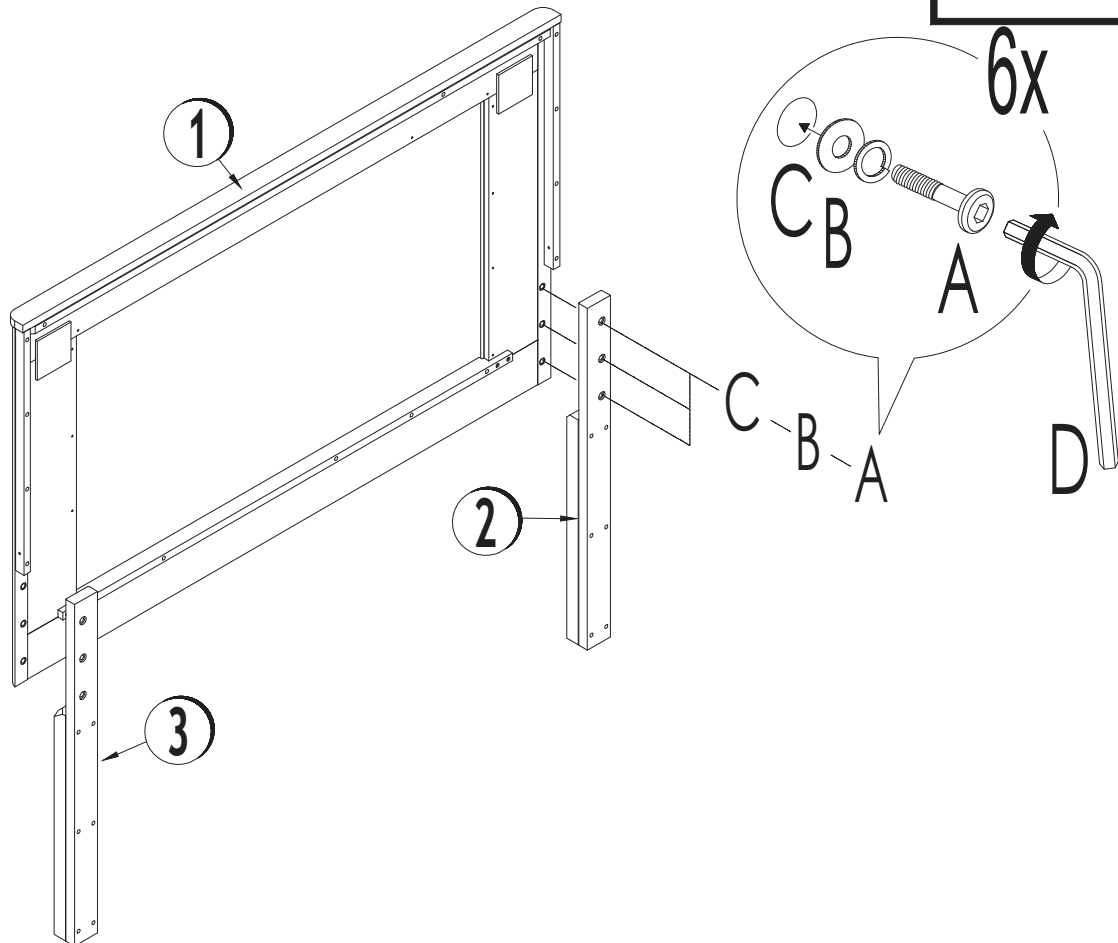
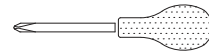

ASSEMBLY INSTRUCTIONS QUEEN BED

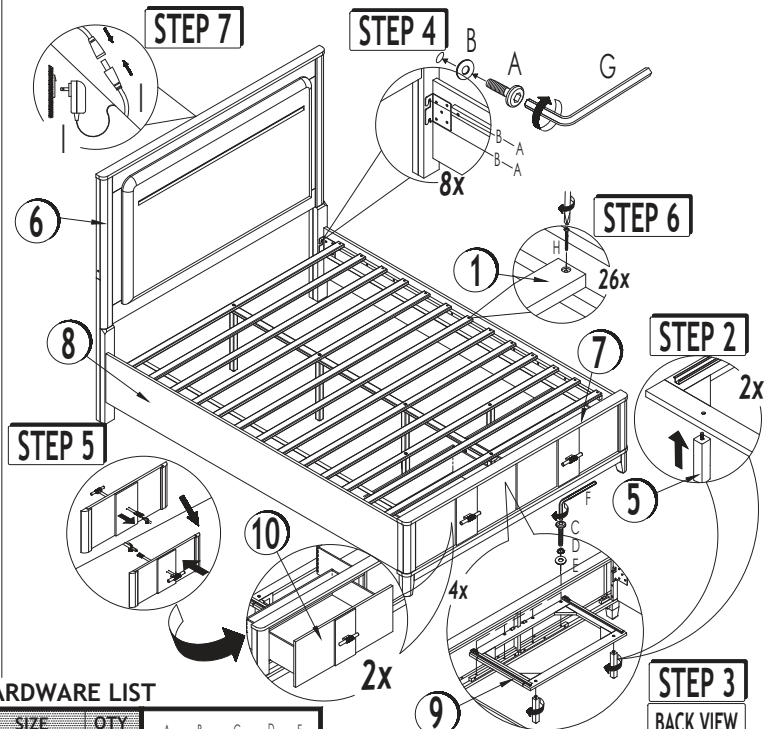
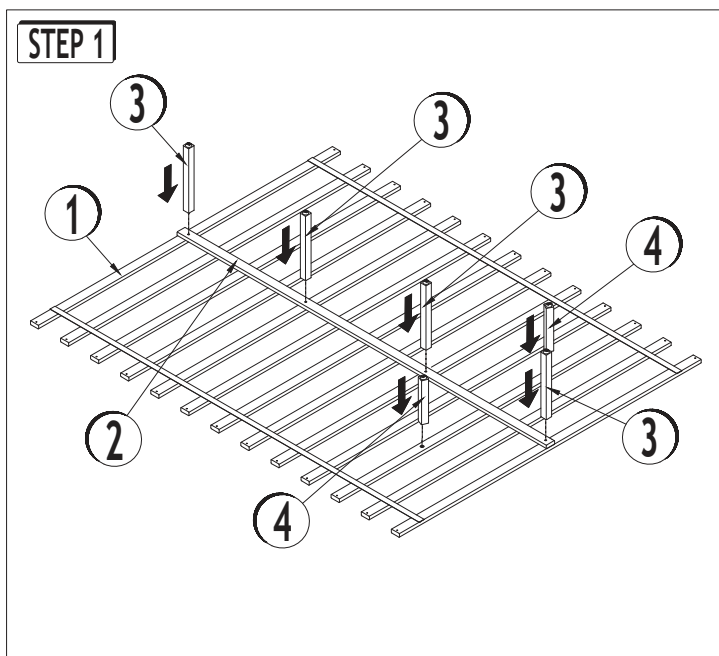

PARTS LIST

NO	DESCRIPTION	QTY
1	SLAT	13 PCS.
2	CENTER RAIL	1 PC.
3	VERTICAL LEG LONG	4 PCS.
4	VERTICAL LEG MEDIUM	2 PCS.
5	VERTICAL LEG SHORT	2 PCS.

PARTS LIST

NO	DESCRIPTION	QTY
6	HEADBOARD	1 PC.
7	FOOTBOARD	1 PC.
8	SIDE RAIL	2 PCS.
9	DRAWER FRAME SUPPORT	1 PC.
10	DRAWER BOX	2 PCS.

HARDWARE LIST

NO	DESCRIPTION	SIZE	QTY
A	JCBB	M8 x 20MM	8 PCS.
B	FLAT WASHER	M8 x 18MM	8 PCS.
C	JCBC	M6 x 35MM	4 PCS.
D	SPRING WASHER	M6	4 PCS.
E	FLAT WASHER	M6 x 13MM	4 PCS.
F	ALLEN KEY	M4	1 PC.
G	ALLEN KEY	M5	1 PC.
H	PANHEAD SCREW	M4 x 30MM	26 PCS.
I	ADAPTER		1 PC.

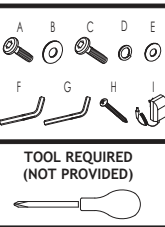

IMPORTANT NOTE :

- * Place all wooden parts on a clean and smooth surface such as a rug or carpet to avoid the parts from being scratched.
- * Check to be sure that you have all parts and hardware.
- * Remove all wrapping materials, including staples & packing straps before you start to assemble.
- * Do not tighten all screws/bolts until all completely assembled.
- * Keep all hardware parts out of reach of children.

STEP 3
BACK VIEW