

Assembly Instructions

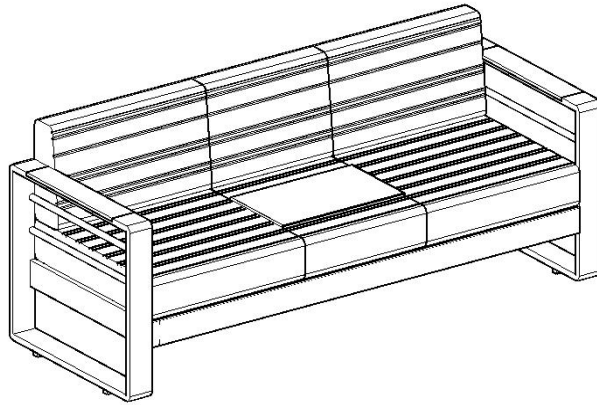







Caution: You must read this before you proceed

Please look in the red bag for hardware packs and legs.

Loveseat

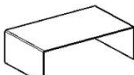

Parts List

Label	Picture	Description	QTY
A		Left Side Panel	1
B		Right Side Panel	1
C		Back Support Bar	1
D		Seat (Labeled with face and bottom)	1
E		U Shape Board	1
F		Middle Cushion	1
G		Seat Cushion	2
H		Back Cushion	2

I		Middle Back Cushion	1
---	--	---------------------	---

Hardware

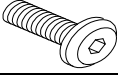
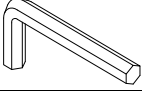
Label	Picture	Description	QTY
①		Bolt(M6*20MM)	5
②		Bolt(M6*25MM)	7
③		Allen Key	1

Assembly Preparation

Before Beginning Assembly:

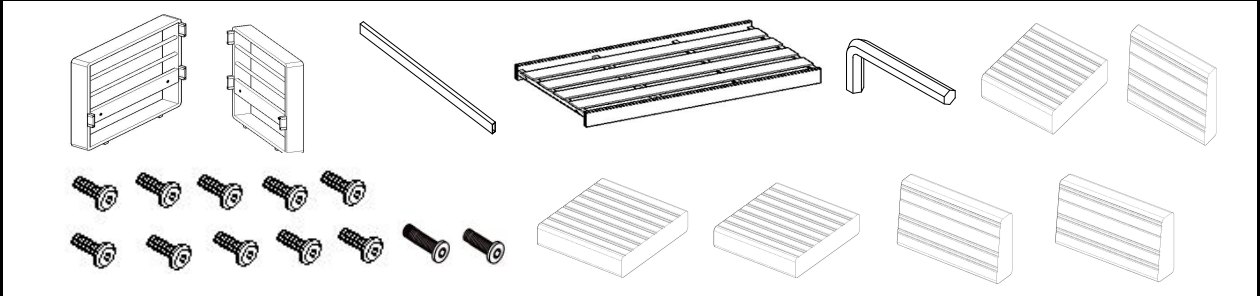

- Read instructions, cover to cover-



- Have 2 adults on hand for assembly-



- Do not assemble on flooring or carpet-



- Assemble on a clean non-marring surface (packing foam)-



- Save all packaging until finished-

Assembly Steps

OVERVIEW

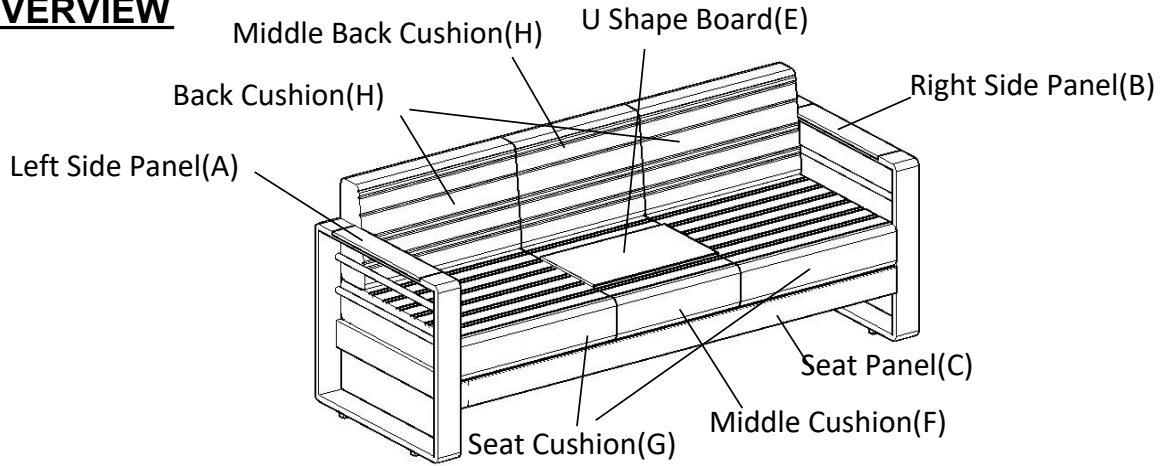

This Loveseat has multiple parts and may require up to 30 minutes to assemble. To give you an overview of the Loveseat parts, the above picture is to help you put the various parts into perspective. Please read through the instructions below to familiarise yourself with the parts and steps before assembly.

Step 1

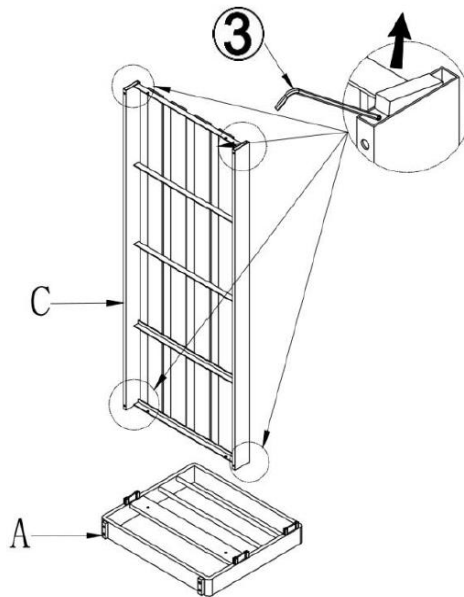

Open the carton and place all the parts onto a clean, non-marring surface.
Remove the plastic plugs (that protect the aluminum from deforming) from the four ends of the Seat Board(C) using the Allen Key(3) as shown above.
please keep the plastic plugs for re-packaging if needed.
Place the Left Side Panel(A) with its inside facing up.
Insert the Seat Panel(C) into the Left Side Panel(A).

Step 2

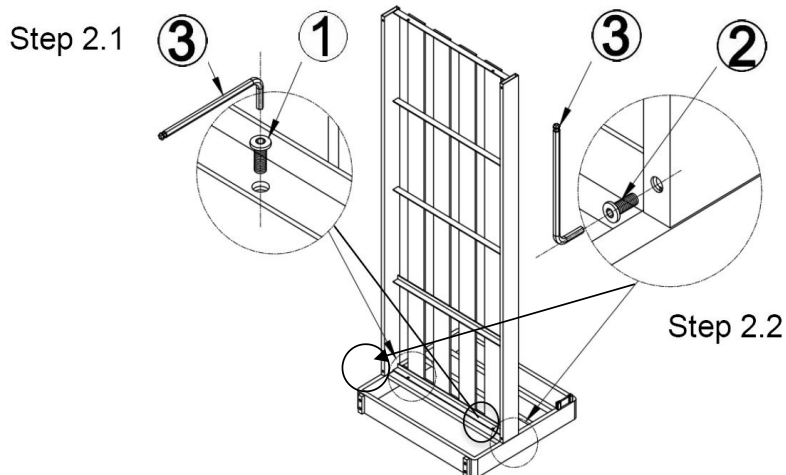

2.1) Attach the Seat Panel(C) to the Left Side Panel(A) using the Bolts(①) with the Allen Key(③) as shown above.
2.2) Attach the Seat Panel(C) to the Left Side Panel(A) using the Bolts(②) with the Allen Key(③) as shown above.
Do not fully tighten the Bolts.

Step 3

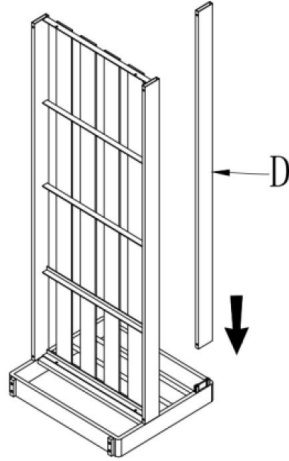

Insert the Back Support Bar(D) into the Left Side Panel(A).

Step 4

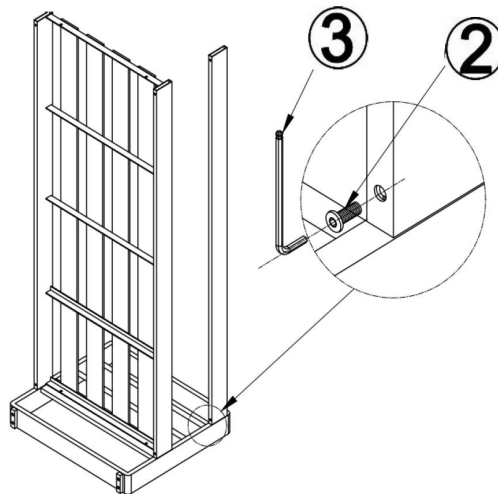

Attach the Back Support Bar(D) to the Side Panel(A) using the Bolts(②) with the Allen Key(③).
Do not fully tighten the Bolts.

Step 5

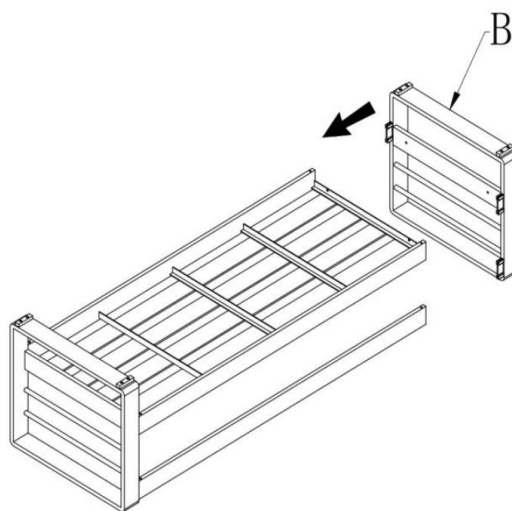

Insert the Right Side Panel(B) into the Back Support Bar(D) and the Seat Panel(C) as shown above.

Step 6

Step 6.1

Step 6.2

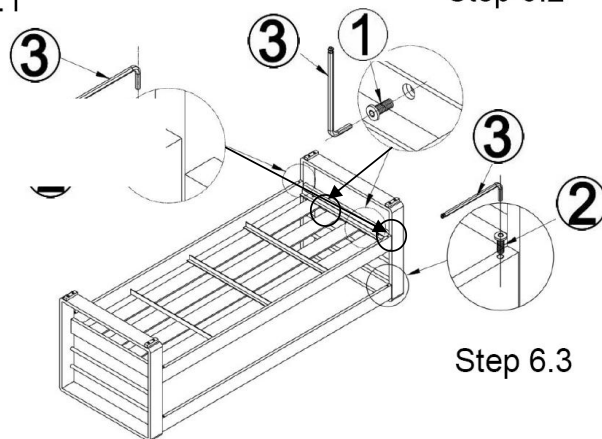

Step 6.3

6.1) Attach the Right Side Panel(B) to the Seat Panel(C) using the Bolts(②) with the Allen Key(③) as shown above.

6.2) Attach the Right Side Panel(B) to the Seat Panel(C) using the Bolts(①) with the Allen Key(③) as shown above.

6.3) Attach the Back Support Bar(D) to the Right Side Panel(B) using the Bolts(②) with the Allen Key(③) as shown above.

Do not fully tighten the Bolts.

Step 7

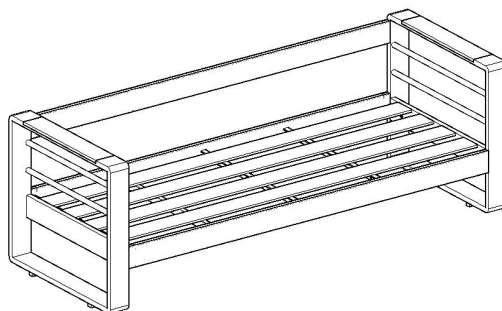

Stand the Loveseat up.

Place the Loveseat on a **LEVEL SURFACE**.

Inspect it and make sure all parts are adequately connected.

Gently and carefully, sit onto the Loveseat.

This will help to align all parts at all joints.

Then carefully get off the Loveseat, and in a sequential manner, proceed to tighten all the Bolts.

When tightening the Bolts, tighten sequentially.

DO NOT tighten any Bolt fully and then move on to the next one.

This may cause the frame to warp.

If there are still wobbles, loosen the Bolts and execute the same process.

If the Loveseat is not stable it could lead to damage of the product.

Note: This step is done best with the assistance of a second adult.

Step 8

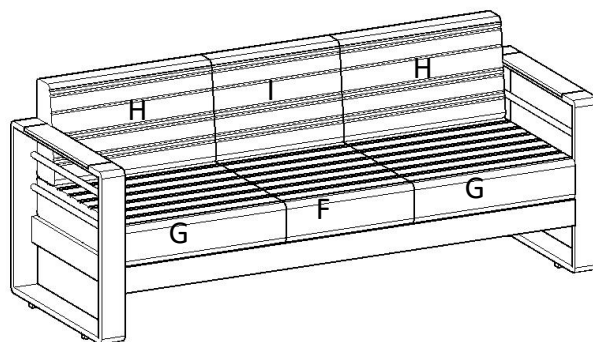





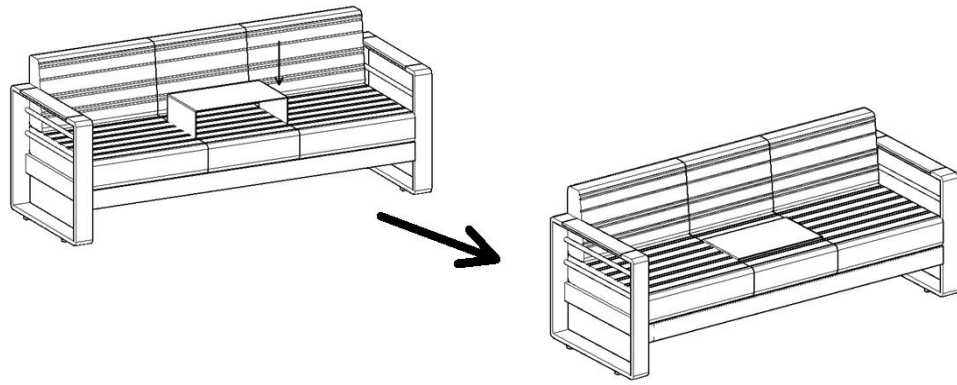





Put the Seat Cushions(G), Back Cushions(H), Middle Back Cushion(I) and Middle Cushion(F) on the Loveseat.

Step 9



Put the U Shape Board(E) on the Middle Cushion(F) as shown above.
Your Loveseat is ready for use.
This Loveseat can only be used on a flat, level surface.

Care & Maintenance

-  ● Do not put hot items directly on furniture surface
 -  ● Do not clean furniture with harsh cleansers or polish.
 -  ● To obtain the longest lifespan of your outdoor products, minimizing exposure to direct sunlight is recommended.
 -  ● Children should not climb or jump on the furniture.
 -  ● Do not write on furniture without a padded barrier to protect the surface.
 -  ● To obtain the longest lifespan of your outdoor products, avoid extended and lengthy exposure to rain, snow, and direct sunshine. Whenever possible cover the product and /or place under patio or awnings.
 -  ● Not for commercial use. For residential use only .
 -  ● Stains may be removed with mild soap solution and damp cloth.
 -  ● Keep away from sources of ignition.
-
-  ● Dust and pick-up spills using a clean, non-colored, lint-free cloth.